

DOME TWEETER LOUDSPEAKER GDWK 8/50

9 5155 136

TECHNICAL DATA

Rated impedance	8	Ω
Voice coil resistance	6,3	Ω
Rated frequency range	4,0 to 20	kHz
Resonance frequency	2,4	kHz
Recommended crossover frequency	7,0	kHz
Power handling capacity, P1/P2, measured with filter,	50/1,5	W
Max. power	100/3	W
Sensitivity	89	dB
Flux density	1	T
Energy in air gap	32	mJ
Air - gap	18/2/0,7	mm
Voice coil height	1,3	mm
Magnet		
- material	ferrite	
- dimensions	50/22/8	mm
- mass	0,063	kg
Mass of loudspeaker	0,25	kg

AVAILABLE VERSIONS

- GDWK 8/50 - 8 Ω , catalogue number 9 5155 136 01

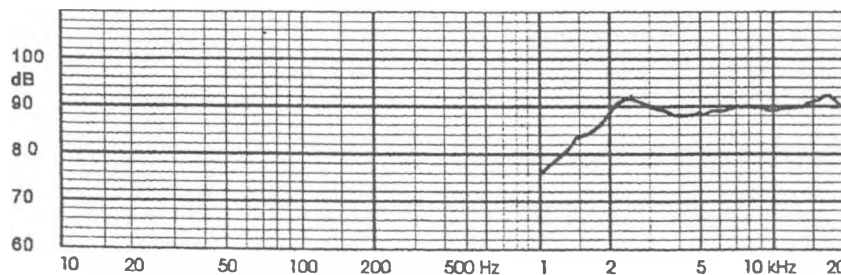
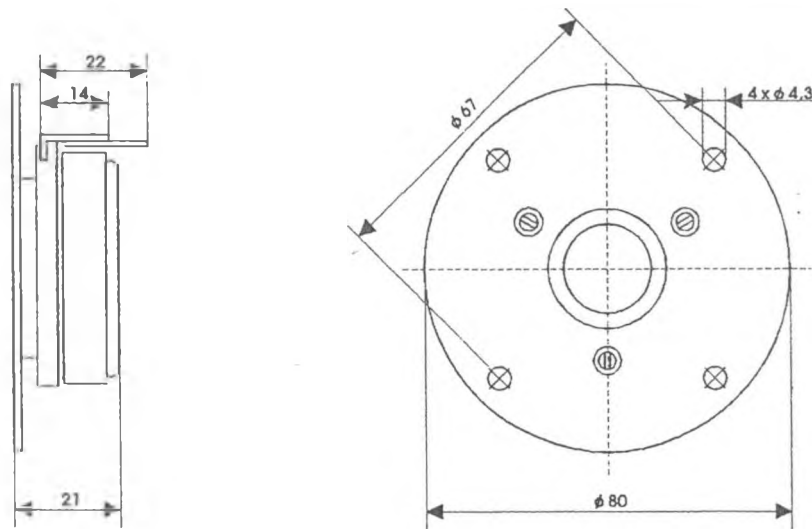

FREQUENCY RESPONSE CURVE
Measured in anechoic room at 1W/1m. Loudspeaker mounted
on IEC baffle.