

AN6096FHN

Transmission and reception IC for cellular telephone

Overview

The AN6096FHN is a transmission and reception IC for a cellular telephone. It is encapsulated in the QFN package which is very thin and very small outline by using our exclusive process method.

It integrates QPSK (Quadrature phase shift keying) modulator for transmission and an IF circuit for reception in a single chip. It contributes to realization of thinner and lighter equipment by adopting a very small package and designing a low power consumption circuit.

Features

- Integrating an orthogonal modulation circuit for transmission and an IF circuit for reception on a single chip
- Low power consumption by using an indirect modulation system in transmission block
- Built-in APC circuit for transmission output adjustment
- High input sensitivity by optimizing circuit in reception circuit
- Built-in RSSI circuit of wide dynamic range in reception block

Applications

- Cellular telephone

Block Diagram

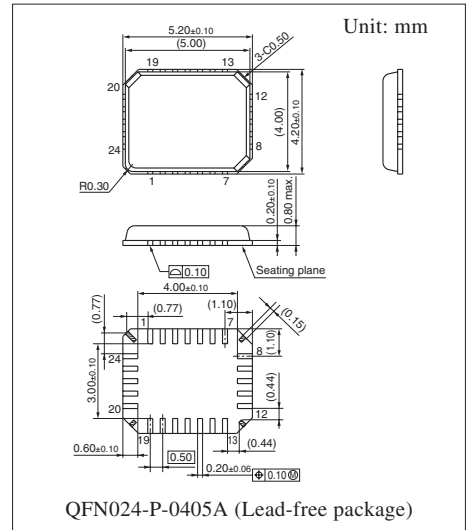
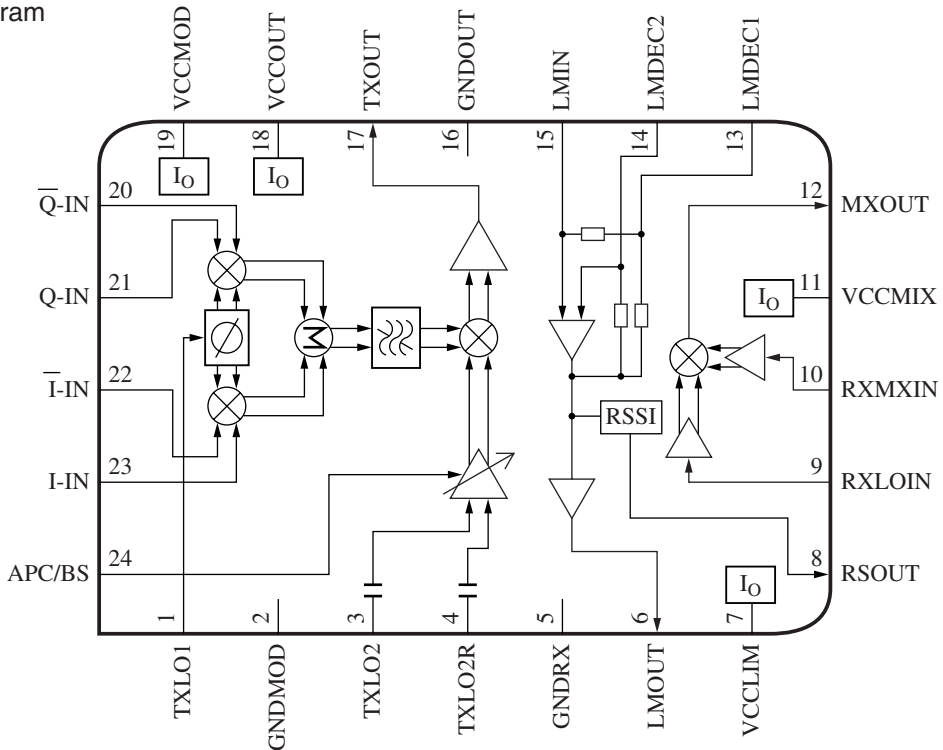

■ Pin Descriptions

Pin No.	Symbol	Description	Pin No.	Symbol	Description
1	TXLO1	TX local 1-in	13	LMDEC1	Lim. decouple 1
2	GNDMOD	GND TX-mod.	14	LMDEC2	Lim. decouple 2
3	TXLO2	TX local 2	15	LIMIN	Lim. in
4	TXLO2R	TX local 2-ref.	16	GNDOUT	GND TX-out
5	GNDRX	GND-RX	17	TXOUT	TX-output
6	LMOUT	Lim. out	18	VCCOUT	V _{CC} TX-out
7	VCCLIM	V _{CC} lim.	19	VCCMOD	V _{CC} TX-mod.
8	RSOUT	RSSI out	20	\bar{Q} -IN	\bar{Q} input
9	RXLOIN	RX local-in	21	Q-IN	Q input
10	RXMXIN	RX mix.-in	22	\bar{I} -IN	\bar{I} input
11	VCCMIX	V _{CC} mix.	23	I-IN	I input
12	MXOUT	Mix. out	24	APC / BS	APC / BS

■ Absolute Maximum Ratings

Parameter	Symbol	Rating	Unit
Supply voltage	V _{CC}	4.2	V
Supply current	I _{CC}	60	mA
Power dissipation *2	P _D	125	mW
Operating ambient temperature *1	T _{opr}	-30 to +80	°C
Storage temperature *1	T _{stg}	-55 to +125	°C

Note) *1: Except for the operating ambient temperature and storage temperature, all ratings are for T_a = 25°C.

*2: The power dissipation shown is for the independent IC without a heat sink at T_a = 80°C. Refer to "■ Application Notes".

■ Recommended Operating Range

Parameter	Symbol	Range	Unit
Supply voltage	V _{CC}	2.7 to 4.0	V

■ Electrical Characteristics at $T_a = 25^\circ\text{C}$

Parameter	Symbol	Conditions	Min	Typ	Max	Unit
Consumption current *1 (Transmission)	I_{CCTX}	Lo1 = 178 MHz, -25 dBm Lo2 = 1 619 MHz, -20 dBm $V_{\text{APC}} = 2.3 \text{ V}$	—	25	33	mA
Sleep current *1	I_{SLTX}	No signal, $V_{\text{APC/BS}} = 0 \text{ V}$	—	0	10	μA
Output level 1 *1	P_{O1}	Lo1 = 178 MHz, -25 dBm Lo2 = 1 607 MHz, -20 dBm $V_{\text{APC}} = 2.3 \text{ V}$	-16	-13	—	dBm
Output level 2 *1	P_{O2}	Lo1 = 178 MHz, -25 dBm Lo2 = 1 631 MHz, -20 dBm $V_{\text{APC}} = 2.3 \text{ V}$	-16	-13	—	dBm
Minimum output level *1	P_{min}	Lo1 = 178 MHz, -25 dBm Lo2 = 1 619 MHz, -20 dBm $V_{\text{APC}} = 1.0 \text{ V}$	—	-50	-43	dBm
Consumption current (Reception) *2	I_{CCRX}	No signal	—	3.2	4.5	mA
Mix. conversion gain *2	G_{MX}	$V_{\text{M1}} = 60 \text{ dB}\mu$, SW1 = b Filter loss: except for -5.5 dB	21	23.5	26	dB
Mix. maximum output amplitude *2	V_{MX}	$V_{\text{M1}} = 105 \text{ dB}\mu$, SW1 = b Filter loss: except for -5.5 dB	101	107	—	dB μ
Lim. voltage gain *2	G_{LM}	$V_{\text{L1}} = 15 \text{ dB}\mu$	80	85	90	dB
Lim. maximum output amplitude *2	V_{LM}	$V_{\text{L1}} = 80 \text{ dB}\mu$, 400 kHz component	0.90	1.25	1.60	V[p-p]
RSSI output voltage 1 *2	V_{S1}	$V_{\text{L1}} = 0 \text{ dB}\mu$	0	0.23	0.6	V
RSSI output voltage 2 *2	V_{S2}	$V_{\text{L1}} = 115 \text{ dB}\mu$	2.31	2.6	2.91	V
RSSI reference output inclination *3	D_{S}	$V_{\text{S}} (V_{\text{IS}}) = V_{\text{S1}} + 0.12 \text{ V}$ $D_{\text{S}} = V_{\text{S}} (V_{\text{IS}} + 75 \text{ dB}\mu) - V(V_{\text{IS}})$	1.39	1.8	2.19	V
RSSI output inclination variation 1 *3	ΔD_{S1}	$\Delta D_{\text{S1}} = 5\{V_{\text{S}} (V_{\text{IS}} + 15 \text{ dB}\mu) - V_{\text{S}} (V_{\text{IS}})\} / D_{\text{S}}$	0.75	1	1.25	—
RSSI output inclination variation 2 *3	ΔD_{S2}	$\Delta D_{\text{S2}} = 5\{V_{\text{S}} (V_{\text{IS}} + 30 \text{ dB}\mu) - V_{\text{S}} (V_{\text{IS}} + 15 \text{ dB}\mu)\} / D_{\text{S}}$	0.75	1	1.25	—
RSSI output inclination variation 3 *3	ΔD_{S3}	$\Delta D_{\text{S3}} = 5\{V_{\text{S}} (V_{\text{IS}} + 45 \text{ dB}\mu) - V_{\text{S}} (V_{\text{IS}} + 30 \text{ dB}\mu)\} / D_{\text{S}}$	0.75	1	1.25	—
RSSI output inclination variation 4 *3	ΔD_{S4}	$\Delta D_{\text{S4}} = 5\{V_{\text{S}} (V_{\text{IS}} + 60 \text{ dB}\mu) - V_{\text{S}} (V_{\text{IS}} + 45 \text{ dB}\mu)\} / D_{\text{S}}$	0.75	1	1.25	—
RSSI output inclination variation 5 *3	ΔD_{S5}	$\Delta D_{\text{S5}} = 5\{V_{\text{S}} (V_{\text{IS}} + 75 \text{ dB}\mu) - V_{\text{S}} (V_{\text{IS}} + 60 \text{ dB}\mu)\} / D_{\text{S}}$	0.75	1	1.25	—

Note) *1: $V_{\text{CC}} = 3.0 \text{ V}$, IQ signal amplitude: 0.35 V[p-p] (single phase), DC bias: 1.6 V, $\pi/4$ QPSK modulation wave

Output frequency of P_{O1} : 1 429.002 5 MHz, Output frequency of P_{O2} : 1 453.002 5 MHz,

Output frequency of P_{min} : 1 441.002 5 MHz

Lo input level is a setting value of signal source (output impedance 50 Ω).

*2: $V_{\text{CC2}} = 3.0 \text{ V}$, SW1 = a, $V_{\text{LO3}} = 90 \text{ dB}\mu$; $f = 129.6 \text{ MHz}$, V_{M1} : $f = 130 \text{ MHz}$, V_{L1} : $f = 400 \text{ kHz}$ (input level of pin 15 excluding the attenuation by matching circuit and filter.) V_{MX} and V_{LM} are measured in high impedance unless otherwise specified.

Lo input level is a setting value of signal source (output impedance 50 Ω).

*3: V_{IS} is the input level of which the RSSI output voltage becomes $V_{\text{S1}} + 0.12 \text{ V}$.

■ Electrical Characteristics at $T_a = 25^\circ\text{C}$ (continued)

• Design reference data

Note) The characteristics listed below are theoretical values based on the IC design and are not guaranteed.

$V_{CC1} = 3.0\text{ V}$ unless otherwise specified.

Lo input level is a setting value of signal source (output impedance 50 Ω).

Parameter	Symbol	Conditions	Min	Typ	Max	Unit
Carrier leak suppression amount ($f_{LO2} - f_{LO1}$)	CL	Lo1 = 178 MHz, -25 dBm Lo2 = 1 619 MHz, -20 dBm $V_{APC} = 2.3\text{ V}$ IO: DC offset adjustment	—	-35	—	dBc
Image leak suppression amount	IL	Lo1 = 178 MHz, -25 dBm Lo2 = 1 619 MHz, -20 dBm $V_{APC} = 2.3\text{ V}$, IO: level adjustment	—	-35	—	dBc
Near spurious suppression amount	DU	Lo1 = 178 MHz, -25 dBm Lo2 = 1 619 MHz, -20 dBm $V_{APC} = 2.3\text{ V}$	—	-70	-65	dBc
Base band distortion suppression amount	BD	Lo1 = 178 MHz, -25 dBm Lo2 = 1 619 MHz, -20 dBm $V_{APC} = 2.3\text{ V}$	—	-40	—	dBc
Adjacent channel leakage power suppression amount (30 kHz detuning)	BL1	Lo1 = 178 MHz, -25 dBm Lo2 = 1 619 MHz, -20 dBm $V_{APC} = 2.3\text{ V}$	—	-45	-38	dBc
Adjacent channel leakage power suppression amount (50 kHz detuning)	BL2	Lo1 = 178 MHz, -25 dBm Lo2 = 1 619 MHz, -20 dBm $V_{APC} = 2.3\text{ V}$	—	-70	-60	dBc
Adjacent channel leakage power suppression amount (100 kHz detuning)	BL3	Lo1 = 178 MHz, -25 dBm Lo2 = 1 619 MHz, -20 dBm $V_{APC} = 2.3\text{ V}$	—	—	-65	dBc
APC variable width	L_{APC}	Lo1 = 178 MHz, -25 dBm Lo2 = 1 619 MHz, -20 dBm $V_{APC} = 1.0\text{ V to }2.3\text{ V}$	30	37	—	dB
APC output level control sensitivity	S_{APC}	Lo1 = 178 MHz, -25 dBm Lo2 = 1 619 MHz, -20 dBm $V_{APC} = 1.0\text{ V / }1.6\text{ V}$	—	46	—	dB/V
In-band output level deviation	ΔP	Lo1 = 178 MHz, -25 dBm Lo2 = 1 607 MHz to 1 631 MHz, -20 dBm $V_{APC} = 2.3\text{ V}$	-1.5	—	+1.5	dB
Modulation precision	EVM	Lo1 = 178 MHz, -25 dBm Lo2 = 1 619 MHz, -20 dBm $V_{APC} = 2.3\text{ V}$	—	2.0	—	%rms

■ Application Notes

- P_D — T_a curves of QFN024-P-0405A

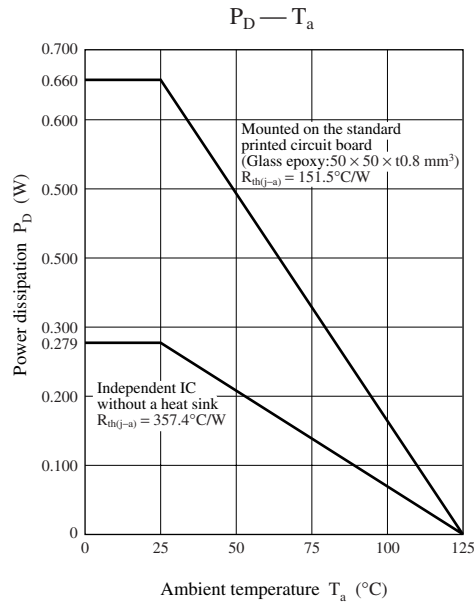

• Main characteristics

Note) Test conditions are the same as "■ Electrical Characteristics" unless otherwise specified.

The characteristics listed below are theoretical values based on the IC design and are not guaranteed.

APC control voltage characteristics

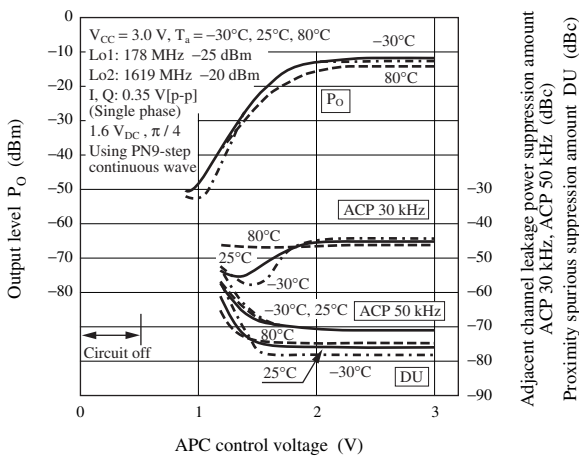

Mix. characteristics

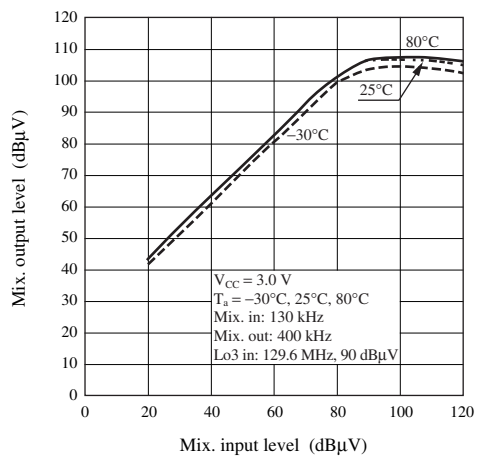

■ Application Notes (continued)

• Main characteristics (continued)

Note) Test conditions are the same as "■ Electrical Characteristics" unless otherwise specified.

The characteristic values below are theoretical values for designing and not guaranteed.

Proximity spurious suppression

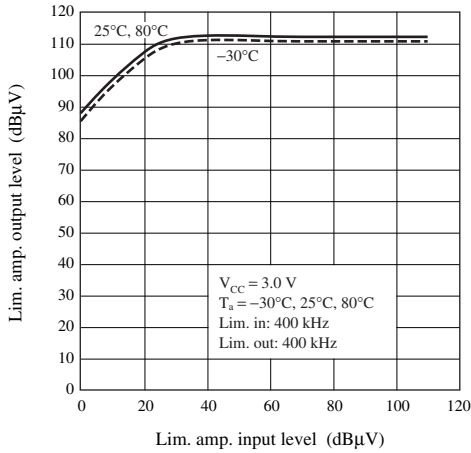

RSSI characteristics

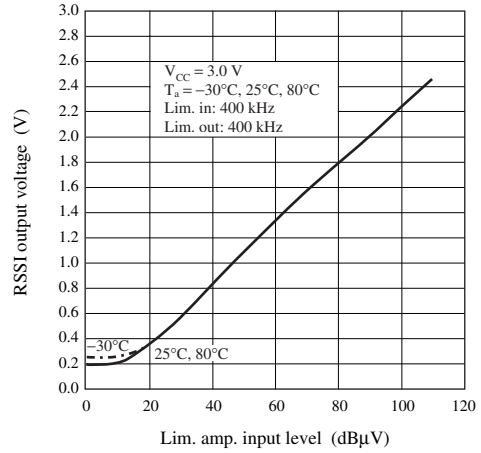

■ Application Circuit Example

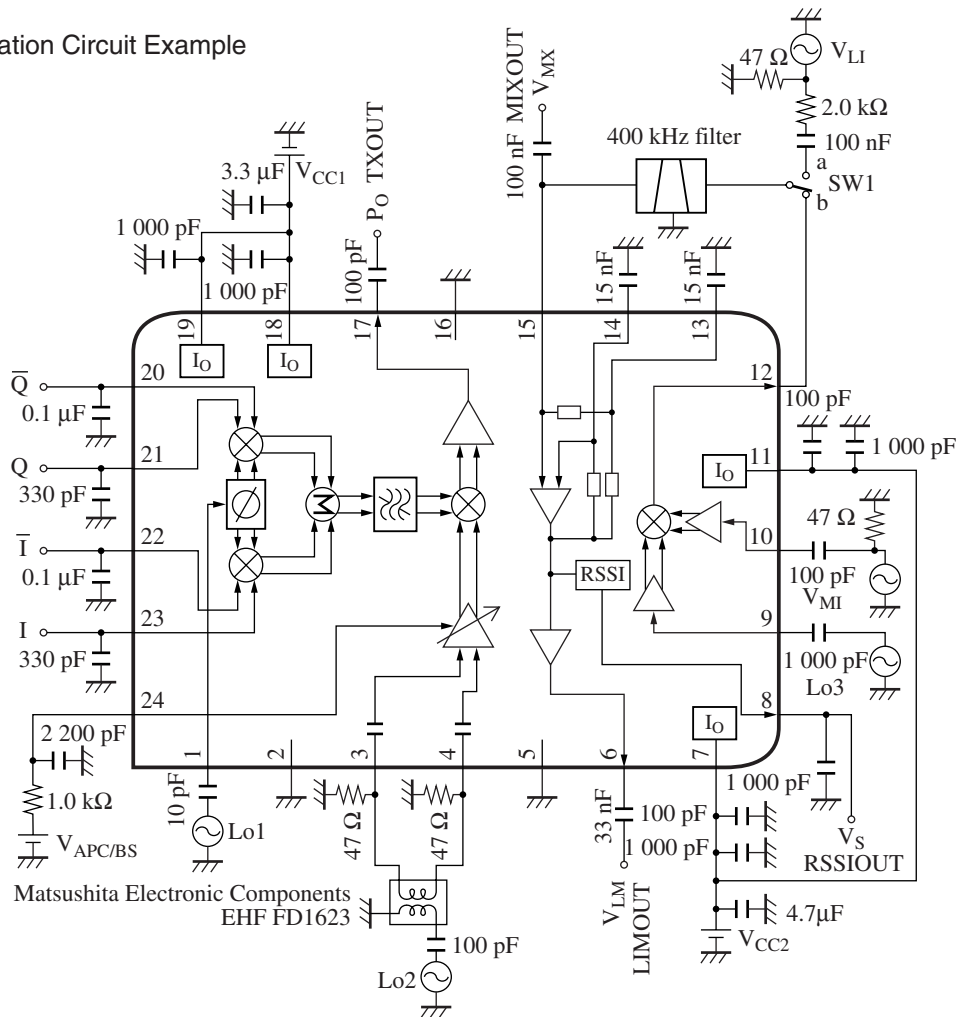

Request for your special attention and precautions in using the technical information and semiconductors described in this material

- (1) An export permit needs to be obtained from the competent authorities of the Japanese Government if any of the products or technologies described in this material and controlled under the "Foreign Exchange and Foreign Trade Law" is to be exported or taken out of Japan.
- (2) The technical information described in this material is limited to showing representative characteristics and applied circuits examples of the products. It neither warrants non-infringement of intellectual property right or any other rights owned by our company or a third party, nor grants any license.
- (3) We are not liable for the infringement of rights owned by a third party arising out of the use of the product or technologies as described in this material.
- (4) The products described in this material are intended to be used for standard applications or general electronic equipment (such as office equipment, communications equipment, measuring instruments and household appliances).
Consult our sales staff in advance for information on the following applications:
 - Special applications (such as for airplanes, aerospace, automobiles, traffic control equipment, combustion equipment, life support systems and safety devices) in which exceptional quality and reliability are required, or if the failure or malfunction of the products may directly jeopardize life or harm the human body.
 - Any applications other than the standard applications intended.
- (5) The products and product specifications described in this material are subject to change without notice for modification and/or improvement. At the final stage of your design, purchasing, or use of the products, therefore, ask for the most up-to-date Product Standards in advance to make sure that the latest specifications satisfy your requirements.
- (6) When designing your equipment, comply with the guaranteed values, in particular those of maximum rating, the range of operating power supply voltage, and heat radiation characteristics. Otherwise, we will not be liable for any defect which may arise later in your equipment.
Even when the products are used within the guaranteed values, take into the consideration of incidence of break down and failure mode, possible to occur to semiconductor products. Measures on the systems such as redundant design, arresting the spread of fire or preventing glitch are recommended in order to prevent physical injury, fire, social damages, for example, by using the products.
- (7) When using products for which damp-proof packing is required, observe the conditions (including shelf life and amount of time let standing of unsealed items) agreed upon when specification sheets are individually exchanged.
- (8) This material may be not reprinted or reproduced whether wholly or partially, without the prior written permission of Matsushita Electric Industrial Co., Ltd.