

CMOS HDB3 (High Density Bipolar 3 Transcoder for 2.048/8.448Mb/s Transmission Applications

The CD22103A is an LSI SOS integrated circuit which performs the HDB3 transmission coding and reception decoding functions with error detection. It is used in 2.048Mb/s and 8.448Mb/s transmission applications. The CD22103A performs HDB3 coding and decoding for data rates from 50Kb/s to 10Mb/s in a manner consistent with CCITT G703 recommendations.

HDB3 transmission coding/reception decoding with code error detection is performed in independent coder and decoder sections. All transmitter and receiver inputs/outputs are TTL compatible.

The HDB3 transmitter coder codes an NRZ binary unipolar input signal (NRZ-IN) and a synchronous transmission clock (CTX) into two HDB3 binary unipolar RZ output signals (+HDB3 OUT, -HDB3 OUT). The TTL compatible output signals +HDB3 OUT, -HDB3 OUT are externally mixed to generate ternary bipolar HDB3 signals for driving transmission lines.

The receiver decoder converts binary unipolar inputs (+HDB3 IN, -HDB3 IN), which were externally split from ternary bipolar HDB3 signals, and a synchronous clock signal (CRX) into binary unipolar NRZ signals (NRZ-OUT).

The CD22103A operates with a 5V ±10% power supply voltage over the full military temperature range at data rates from 50Kb/s up to 10Mb/s.

Block Diagram

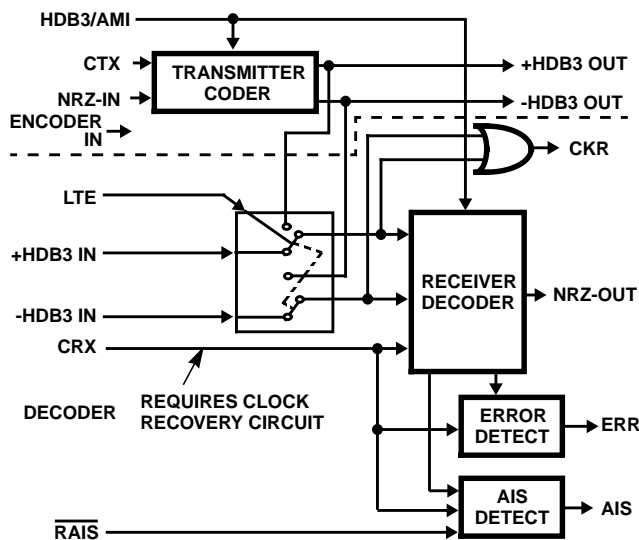

Features

- HDB3 Coding and Decoding for Data Rates from 50Kb/s to 10Mb/s in a Manner Consistent with CCITT G703 Recommendations
- HDB3/AMI Transmission Coding/Reception Decoding with Code Error Detection is Performed in Independent Coder and Decoder Sections
- All Transmitter and Receiver Inputs/Outputs are TTL Compatible
- Internal Loop Test Capability
- Pin and Functionally Compatible with Type MJ1471

Ordering Information

PART NUMBER	TEMP. RANGE (°C)	PACKAGE	PKG. NO.
CD22103AD	-55 to 125	16 Ld SBDIP	D16.3
CD22103AE	-40 to 85	16 Ld PDIP	E16.3

Pinout

**CD22103A (PDIP, SBDIP)
TOP VIEW**

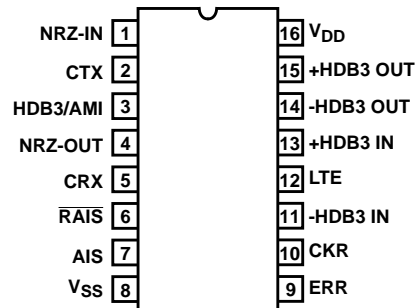

Absolute Maximum Ratings

Supply Voltage (V_{DD})
 (Voltages referenced to V_{SS} Terminal) -0.5 to 8V
 Supply Voltage Range
 For T_A = Full Package Temperature Range 4.5V to 5.5V
 Input Voltage (All Inputs) -0.5 to $V_{DD} + 0.5V$
 Input Current (Any One Input) $\pm 10mA$
 Power Dissipation
 For T_A = -40°C to 60°C (Package Type E) 500mW
 For T_A = 60°C to 85°C
 (Package Type E) Derate Linearly 12mW/°C to 200mW
 For T_A = -55°C to 100°C (Package Type D) 500mW
 For T_A = 100°C to 125°C
 (Package Type D) Derate Linearly 12mW/°C to 200mW
 Device Dissipation per Output Transistor
 For T_A = Full Package Temperature Range (All Types) 100mW

Thermal Information

Maximum Junction Temperature 175°C
 Maximum Junction Temperature (Plastic Package) 150°C
 Maximum Storage Temperature Range -65°C $\leq T_A \leq$ 150°C
 Maximum Lead Temperature (Soldering 10s) 300°C

Operating Conditions

Temperature Range
 Package Type D -55°C $\leq T_A \leq$ 125°C
 Package Type E -40°C $\leq T_A \leq$ 85°C

CAUTION: Stresses above those listed in "Absolute Maximum Ratings" may cause permanent damage to the device. This is a stress only rating and operation of the device at these or any other conditions above those indicated in the operational sections of this specification is not implied.

Electrical Specifications $V_{DD} = 5V \pm 10\%$, $T_A = 25^\circ C$.

PARAMETER	SYMBOL	TEST CONDITIONS	MIN	TYP	MAX	UNITS
STATIC SPECIFICATIONS						
Quiescent Device Current	I_{DD}		-	-	100	μA
Operating Device Current		$f_{CL} = 10MHz$	-	-	8	mA
HDB3 Output Low (Sink) Current	I_{OL1}	$V_{OL} = 0.5V$	1.6	-	-	mA
HDB3 Output High (Source) Current	I_{OH1}	$V_{OH} = 2.8V$	-10	-	-	mA
All Other Outputs Low (Sink) Current	I_{OL2}	$V_{OL} = 0.5V$	1.6	-	-	mA
All Other Outputs High (Source) Current	I_{OH2}	$V_{OH} = 2.8V$	-1.6	-	-	mA
Input Low Current	I_{IL}		-	-	-1	μA
Input High Current	I_{IH}		-	-	1	μA
Input Low Voltage	V_{IL}		-	-	0.8	V
Input High Voltage	V_{IH}		2	-	-	V
Input Capacitance	I_{IN}		-	-	5	pF

Electrical Specifications $T_A = -40^\circ C$ to $85^\circ C$ for Plastic Package; $-55^\circ C$ to $125^\circ C$ for Ceramic Package; $V_{DD} = 4.5V$ to $5.5V$; $C_L = 15pF$.

PARAMETER	SYMBOL	FIGURE	MIN	TYP	MAX	UNITS
DYNAMIC INPUT						
CTX, CRX Input Frequency	f_{CTX}, f_{CRX}		0.05	-	10	MHz
CTX, CRX Input Rise Time	t_{RCL}	3	-	-	1	μs
Fall Time	t_{FCL}	3	-	-	1	μs
NRZ-IN to CTX						
Data Setup Time	t_S	3	15	-	-	ns
Data Hold Time	t_H	3	15	-	-	ns
HDB3 IN to CRX						
Data Setup Time	t_S	4	15	-	-	ns
Data Hold Time	t_H	3	0	-	-	ns

Electrical Specifications $T_A = -40^{\circ}\text{C}$ to 85°C for Plastic Package; -55°C to 125°C for Ceramic Package; $V_{DD} = 4.5\text{V}$ to 5.5V ; $C_L = 15\text{pF}$. (Continued)

PARAMETER	SYMBOL	FIGURE	MIN	TYP	MAX	UNITS
CRX to CKR (CRX = 8.448MHz)						
Pretrigger	t_P	5	-	-	20	ns
Delay	t_D	5	-	-	20	ns
DYNAMIC OUTPUT						
Transmitter Coder, CTX to HDB3 OUT:						
Data Propagation Delay Time	t_{DD}	3	-	-	90	ns
Handling Delay Time	t_{HD}	1	-	4	-	Clock Period
HDB3 OUT Output Pulse Width (Clock duty cycle = 50%)						
$f_{CL} = 2.048\text{MHz}$	t_W	3	238	-	260	ns
$f_{CL} = 8.448\text{MHz}$	t_W	3	53	-	65	ns
Receiver Decoder CRX to NRZ OUT:						
Data Propagation Delay Times	t_{DD}	4	-	-	90	ns
Handling Delay Time	t_{HD}	2	-	4	-	Clock Period
HDB3 IN to CKR HDB3 Propagation Delay Time						
LTE = 0	$t_{IN\ CKR}$	4	-	-	65	ns
LTE = 1		4	-	-	30	ns

Functional Description

The CD22103A is designed to code and decode HDB3 signals which are coded as binary digital signals (NRZ-IN) and (+HDB3 IN, -HDB3 IN), accompanied by sampling clocks (CTX) and (CRX). The two binary coded HDB3 outputs, (+HDB3 OUT, -HDB3 OUT) may be externally mixed to create the ternary HDB3 signals (See Figure 1).

The two binary HDB3 input signals have been split from the input ternary HDB3 in an external line receiver.

The receiver decoder converts binary unipolar inputs (+HDB3 IN, -HDB3 IN), which were externally split from ternary bipolar HDB3 signals, and a synchronous clock signal (CRX) into binary unipolar NRZ signals (NRZ-OUT).

Received signals not consistent with HDB3 coding rules are detected as errors. The receiver error output (ERR) is active high during one CRX period of each bit of received data that is inconsistent with HDB3 coding rules.

An input string consisting of all ones (or marks) is detected and signaled by a high level at the Alarm Signal (AIS) output. The AIS output is set to a high level when less than three zeros are received during two consecutive periods of the Reset Alarm Inhibit Signal (RAIS). The AIS output is subsequently reset to a low level when three or more zeros are received during two periods of the reset signal (RAIS).

A diagnostic Loop-Test Mode may be entered by driving the Loop Test Enable Input (LTE) high. In this mode the HDB3

transmitter outputs (+HDB3 OUT, -HDB3 OUT) are internally connected to the HDB3 receiver inputs, and the external HDB3 receiver inputs, and the external HDB3 receiver inputs (+HDB3 IN, -HDB3 IN) are disabled. The NRZ binary output signal (NRZ - OUT) corresponds to the NRZ binary input signal (NRZ - IN) delayed by approximately 8 clock periods.

The Clock Receiver Output (CKR) is the product of the two HDB3 input signals or'ed together. The CRX clock signal may be derived from the CKR signal with external clock extraction circuitry. In the Loop Test Mode (LTE = 1) CKR is the product of the +HDB3 OUT and -HDB3 OUT signals or'ed together.

The CD22103A may also be used to perform the AMI to NRZ coding/decoding function. To use the CD22103A in this mode, the HDB3/AMI control input is driven low.

Error Detection

Received HDB3/AMI binary input signals are checked for coding violations, and an error signal (ERR) is generated as described below.

HDB3 SIGNALS HDB3/AML = HIGH

The error signal (ERR) is flagged high for one CTX period if a violation pulse ($\pm V$) is received of the same polarity as the last received violation pulse.

A violation pulse ($\pm V$) is considered a reception error and does not cause replacement of the last string of 4 bits to zeros, if:

The received 4 data bits previous to reception of the violation pulse have not been the sequence BX00 (where X = don't care). The error signal (ERR) remains low.

NOTES:

1. The data sequences B000V and BB00V are valid HDB3 codings of the NRZ binary sequence 10000.
2. The error signal (ERR) count, is the accurate number of all single bit errors.

AML SIGNALS HDB3/AML = LOW

A coding error (ERR) is signaled when a violation pulse (+V) is received.

IN EITHER THE HDB3 OR AMI MODE

When high levels appear simultaneously on both HDB3 inputs (+ HDB3 IN, -HDB3 IN) a logical one is assumed in the HDB3/AMI input stream and the error signal (ERR) goes high for the duration of the violation.

Alarm Inhibit Signal

The alarm output (AIS) is set high if, in two successive periods of the external Reset Alarm Signal ($\overline{\text{RAIS}}$), less than three zeros are received.

The alarm output (AIS) is reset low when three or more zeros are received during two Reset Alarm Signal periods.

Timing Waveforms

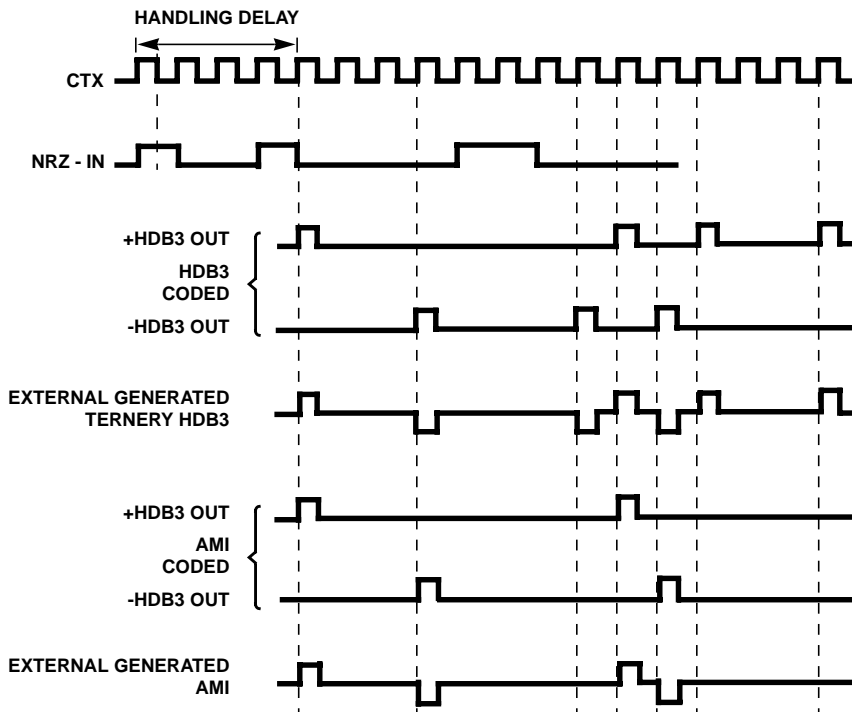

FIGURE 1. TRANSMITTER CODER OPERATION TIMING WAVEFORMS - NRZ TO HDB3/AMI CODING

Transcoder Operation

Transmitter Coder (See Figure 1)

The HDB3/AMI transmitter coder operates on 4-bit serial strings of NRZ binary data and a synchronous transmitter clock (CTX). NRZ binary data is serially clocked into the transmitter on the negative transition of the (CTX) clock. HDB3/AMI coding is performed on the 4-bit string, and HDB3/AMI binary output data is clocked out to the (+HDB3 OUT, -HDB3 OUT) outputs on the positive transition of the transmitter clock (CTX) 3-1/2 clock pulses after the data appeared at the (NRZ-IN) input.

Receiver Decoder (See Figure 2)

The HDB3/AMI receiver decoder operates on 4-bit serial strings of binary coded HDB3/AMI signals, and a synchronous receiver clock (CRX), HDB3/AMI binary data is serially clocked into the receiver on the positive transition of the (CRX) clock. HDB3/AMI decoding is performed on the 4-bit string, and NRZ binary output data is clocked out to the (NRZ-OUT) output on the positive transition of the receiver clock (CRX) 4 clock pulses after the data appeared at the (+HDB3 IN, -HDB3 IN) inputs.

Timing Waveforms (Continued)

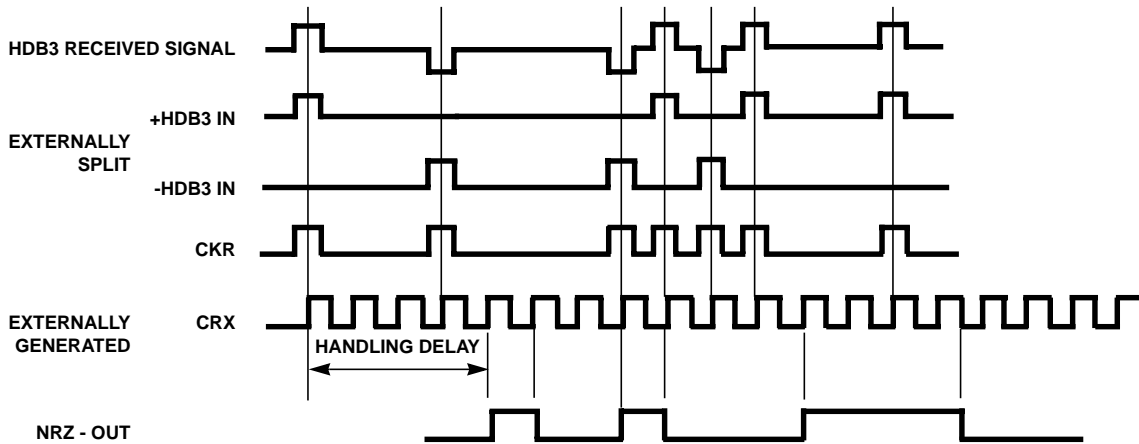

FIGURE 2. RECEIVER DECODER OPERATION TIMING WAVEFORMS - HDB3 TO NRZ DECODING

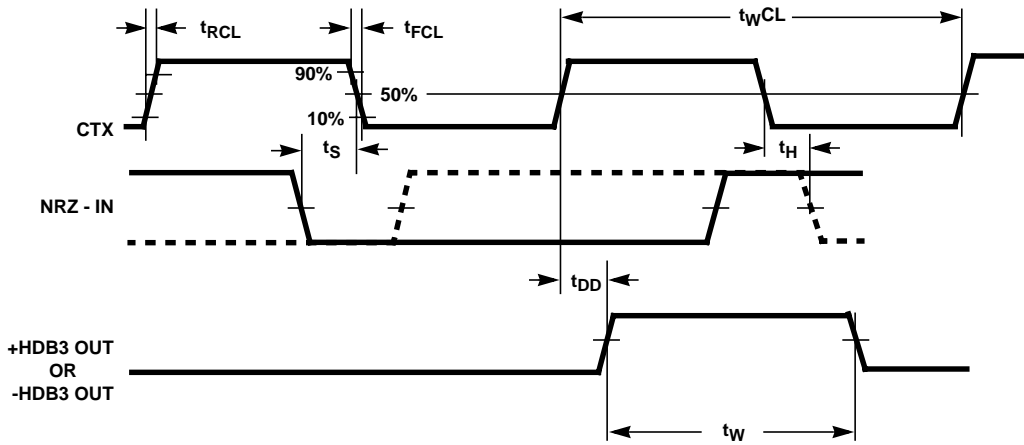

FIGURE 3. TRANSMITTER CODER TIMING WAVEFORM

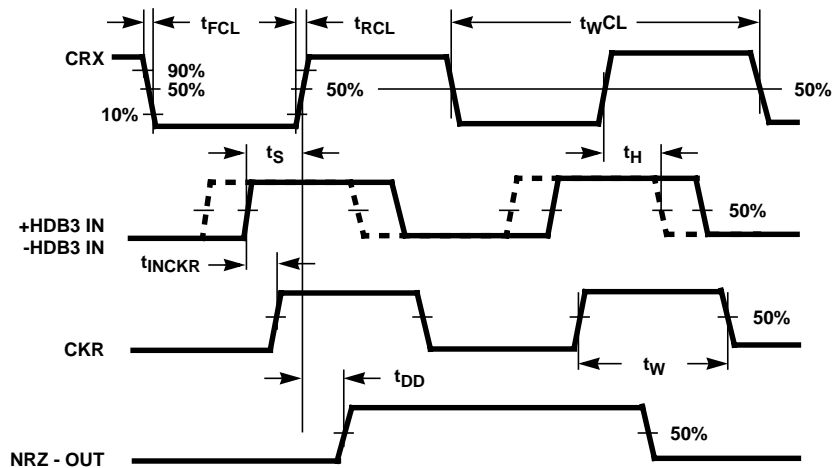

FIGURE 4. INPUT REQUIREMENTS AND OUTPUT CHARACTERISTICS

Timing Waveforms (Continued)

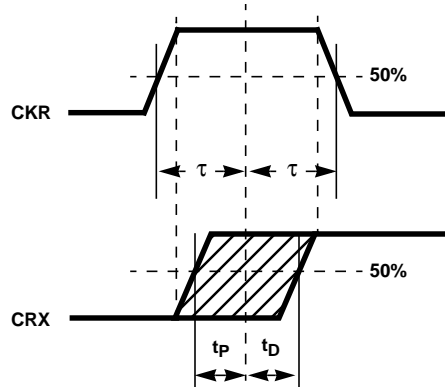

FIGURE 5. RECONSTRUCTION REQUIREMENTS

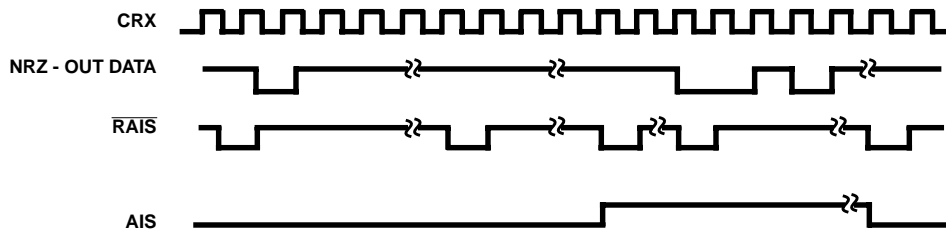

FIGURE 6. RECEIVER ALARM-INHIBIT-SIGNALS TIMING WAVEFORMS

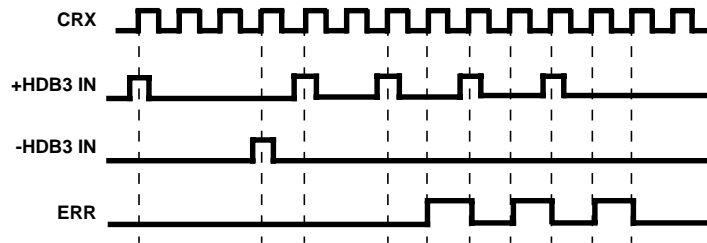

FIGURE 7. RECEIVER ERROR-SIGNALS TIMING WAVEFORMS

Definition of HDB3 Code Used in CD22103A HDB3 Transcoder (As Per CCITRT G703 Annex Recommendations) and Error Detection

Coding Of A Binary Signal Into An HDB3 Signal Is Done According To The Following Rules:

1. HDB3 signal is pseudoternary; the three states are denoted B+, B-, and 0.
2. Spaces (zeros) in the binary NRZ signal are coded as spaces in the HDB3 signal. For strings of four spaces, however, special rules apply (See Item 4 below).
3. Marks (ones) in the binary signal are coded alternately as B+ and B- in the HDB3 signal (alternate mark inversion). Violations of the rule of alternate mark inversion are introduced when coding strings of four spaces (See Item 4 below).

4. Strings of four spaces in the binary signal are coded according to the following rules:
 - A. The first space of a string is coded as a space if the polarity of the preceding mark of the HDB3 signal has a polarity opposite to the preceding violation and is not a violation by itself; it is coded as a mark, i.e., not a violation (i.e., B+ or B-), if the preceding mark of the HDB3 signal has the same polarity as that of the preceding violation or is by itself a violation.
This rule ensures that successive violations are of alternate polarity so that no DC component is introduced.
 - B. The second and third spaces of a string are always coded as spaces.
 - C. The last space of a string of four is always coded as a mark, the polarity of which is such that it violates the rule of alternate mark inversion. Such violations are denoted V+ or V- according to their polarity.

All Intersil semiconductor products are manufactured, assembled and tested under **ISO9000** quality systems certification.

Intersil semiconductor products are sold by description only. Intersil Corporation reserves the right to make changes in circuit design and/or specifications at any time without notice. Accordingly, the reader is cautioned to verify that data sheets are current before placing orders. Information furnished by Intersil is believed to be accurate and reliable. However, no responsibility is assumed by Intersil or its subsidiaries for its use; nor for any infringements of patents or other rights of third parties which may result from its use. No license is granted by implication or otherwise under any patent or patent rights of Intersil or its subsidiaries.

For information regarding Intersil Corporation and its products, see web site **www.intersil.com**

Sales Office Headquarters

NORTH AMERICA

Intersil Corporation
P. O. Box 883, Mail Stop 53-204
Melbourne, FL 32902
TEL: (321) 724-7000
FAX: (321) 724-7240

EUROPE

Intersil SA
Mercure Center
100, Rue de la Fusee
1130 Brussels, Belgium
TEL: (32) 2.724.2111
FAX: (32) 2.724.22.05

ASIA

Intersil (Taiwan) Ltd.
7F-6, No. 101 Fu Hsing North Road
Taipei, Taiwan
Republic of China
TEL: (886) 2 2716 9310
FAX: (886) 2 2715 3029