



CD4006BM/CD4006BC 18-Stage Static Shift Register

General Description

The CD4006BM/CD4006BC 18-stage static shift register is comprised of four separate shift register sections, two sections of four stages and two sections of five stages. Each section has an independent data input. Outputs are available at the fourth stage and the fifth stage of each section. A common clock signal is used for all stages. Data is shifted to the next stage on the negative-going transition of the clock. Through appropriate connections of inputs and outputs, multiple register sections of 4, 5, 8, and 9 stages, or single register sections of 10, 12, 13, 14, 16, 17, and 18 stages can be implemented using one package.

Features

- Wide supply voltage range 3.0V to 15V
- High noise immunity 0.45 V_{DD} (typ.)
- Low power TTL compatibility fan out of 2 driving 74L or 1 driving 74LS
- Low clock input capacitance 6 pF (typ.)
- Medium speed 10 MHz (typ.) (with V_{DD} = 10V)
- Low power
- Fully static operation

Logic Diagrams

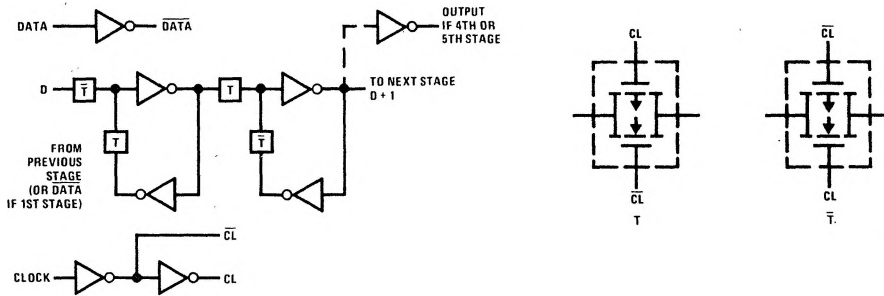

Connection Diagram

Truth Table

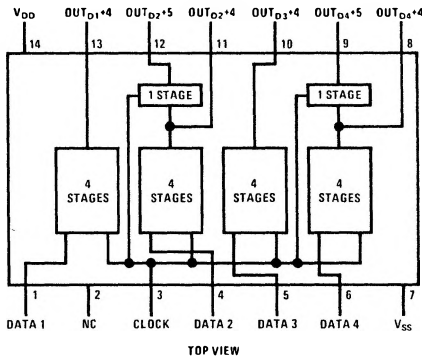

D	CL ^Δ	D+1
0		0
1		1
X		NC

X = Don't care
 Δ = Level change
 NC = No change

Absolute Maximum Ratings

(Notes 1 and 2)

V _{DD} DC Supply Voltage	-0.5 to +18 V _{DC}
V _{IN} Input Voltage	-0.5 to V _{DD} + 0.5 V _{DC}
T _S Storage Temperature Range	-65°C to +150°C
P _D Package Dissipation	500 mW
T _L Lead Temperature (Soldering, 10 seconds)	300°C

Recommended Operating Conditions

(Note 2)

V _{DD} DC Supply Voltage	+3.0 to +15 V
V _{IN} Input Voltage	0 to V _{DD} V _{DC}
T _A Operating Temperature Range	-55°C to +125°C
	CD4006BM
	CD4006BC
	-40°C to +85°C

DC Electrical Characteristics CD4006BM (Note 2)

Parameter	Conditions	-55°C		25°C			125°C		Units
		Min.	Max.	Min.	Typ.	Max.	Min.	Max.	
I _{DD} Quiescent Device Current	V _{DD} = 5.0 V		5.0		0.005	5.0		150	μA
	V _{DD} = 10 V		10		0.010	10		300	μA
	V _{DD} = 15 V		20		0.015	20		600	μA
V _{OL} Low Level Output Voltage	V _{DD} = 5.0 V		0.05		0	0.05		0.05	V
	V _{DD} = 10 V		0.05		0	0.05		0.05	V
	V _{DD} = 15 V		0.05		0	0.05		0.05	V
V _{OH} High Level Output Voltage	V _{DD} = 5.0 V	4.95		4.95	5.0		4.95		V
	V _{DD} = 10 V	9.95		9.95	10		9.95		V
	V _{DD} = 15 V	14.95		14.95	15		14.95		V
V _{IL} Low Level Input Voltage	V _{DD} = 5.0 V, V _O = 0.5 V or 4.5 V		1.5		2.25	1.5		1.5	V
	V _{DD} = 10 V, V _O = 1.0 V or 9.0 V		3.0		4.50	3.0		3.0	V
	V _{DD} = 15 V, V _O = 1.5 V or 13.5 V		4.0		6.75	4.0		4.0	V
V _{IH} High Level Input Voltage	V _{DD} = 5.0 V, V _O = 0.5 V or 4.5 V	3.5		3.5	2.75		3.5		V
	V _{DD} = 5.0 V, V _O = 1.0 V or 9.0 V	7.0		7.0	5.50		7.0		V
	V _{DD} = 15 V, V _O = 1.5 V or 13.5 V	11.0		11.0	8.25		11.0		V
I _{OL} Low Level Output Current	V _{DD} = 5.0 V, V _O = 0.4 V	0.64		0.51	0.88		0.36		mA
	V _{DD} = 10 V, V _O = 0.5 V	1.6		1.3	2.25		0.9		mA
	V _{DD} = 15 V, V _O = 1.5 V	4.2		3.4	8.8		2.4		mA
I _{OH} High Level Output Current	V _{DD} = 5.0 V, V _O = 4.6 V	-0.64		-0.51	-0.88		-0.36		mA
	V _{DD} = 10 V, V _O = 9.5 V	-1.6		-1.3	-2.25		-0.9		mA
	V _{DD} = 15 V, V _O = 13.5 V	-4.2		-3.4	-8.8		-2.4		mA
I _{IN} Input Current	V _{DD} = 15 V, V _{IN} = 0 V	-0.1		-0.1	-10 ⁻⁵		-1.0		μA
	V _{DD} = 15 V, V _{IN} = 15 V		0.1		10 ⁻⁵	0.1		1.0	μA

DC Electrical Characteristics CD4006BC (Note 2)

Parameter	Conditions	-40°C		25°C			85°C		Units
		Min.	Max.	Min.	Typ.	Max.	Min.	Max.	
I _{DD} Quiescent Device Current	V _{DD} = 5.0 V		20		0.005	20		150	μA
	V _{DD} = 10 V		40		0.010	40		300	μA
	V _{DD} = 15 V		80		0.015	80		600	μA
V _{OL} Low Level Output Voltage	V _{DD} = 5.0 V		0.05		0	0.05		0.05	V
	V _{DD} = 10 V		0.05		0	0.05		0.05	V
	V _{DD} = 15 V		0.05		0	0.05		0.05	V
V _{OH} High Level Output Voltage	V _{DD} = 5.0 V	4.95		4.95	5.0		4.95		V
	V _{DD} = 10 V	9.95		9.95	10		9.95		V
	V _{DD} = 15 V	14.95		14.95	15		14.95		V
V _{IL} Low Level Input Voltage	V _{DD} = 5.0 V, V _O = 0.5 V or 4.5 V		1.5		2.25	1.5		1.5	V
	V _{DD} = 10 V, V _O = 1.0 V or 9.0 V		3.0		4.5	3.0		3.0	V
	V _{DD} = 15 V, V _O = 1.5 V or 13.5 V		4.0		6.75	4.0		4.0	V
V _{IH} High Level Input Voltage	V _{DD} = 5.0 V, V _O = 0.5 V or 4.5 V	3.5		3.5	2.75		3.5		V
	V _{DD} = 5.0 V, V _O = 1.0 V or 9.0 V	7.0		7.0	5.5		7.0		V
	V _{DD} = 15 V, V _O = 1.5 V or 13.5 V	11		11	8.25		11		V

DC Electrical Characteristics (cont'd) CD4006BC (Note 2)

Parameter	Conditions	-55°C		25°C			85°C		Units
		Min.	Max.	Min.	Typ.	Max.	Min.	Max.	
I_{OL} Low Level Output Current	$V_{DD} = 5.0V, V_O = 0.4V$	0.52		0.44	0.88		0.36		mA
	$V_{DD} = 10V, V_O = 0.5V$	1.3		1.1	2.25		0.9		mA
	$V_{DD} = 15V, V_O = 1.5V$	3.6		3.0	8.8		2.4		mA
I_{OH} High Level Output Current	$V_{IL} = 0V, V_{IH} = V_{DD}$								
	$V_{DD} = 5.0V, V_O = 4.6V$	-0.52		-0.44	-0.88		-0.36		mA
	$V_{DD} = 10V, V_O = 9.5V$	-1.3		-1.1	-2.25		-0.9		mA
	$V_{DD} = 15V, V_O = 13.5V$	-3.6		-3.0	-8.8	-8.8	-2.4		mA
I_{IN} Input Current	$V_{DD} = 15V, V_{IN} = 0V$	-0.3		-0.3	-10^{-5}		-1.0		μA
	$V_{DD} = 15V, V_{IN} = 15V$		0.3		10^{-5}	0.3		1.0	μA

AC Electrical Characteristics CD4006BM/CD4006BC $T_A = 25^\circ C, C_L = 50 pF$, unless otherwise noted

Parameter	Conditions	Min.	Typ.	Max.	Units
t_{PLH}, t_{PHL} Propagation Delay Time ($t_{PLH} = t_{PHL}$)	$V_{DD} = 5.0V$ $V_{DD} = 10V$ $V_{DD} = 15V$		200 100 80	400 200 150	ns
t_{TLH}, t_{THL} Transition Time ($t_{TLH} = t_{THL}$)	$V_{DD} = 5.0V$		100	200	ns
	$V_{DD} = 10V$		50	100	ns
	$V_{DD} = 15V$		40	80	ns
t_{WL}, t_{WH} Minimum Clock Pulse Width ($t_{WL} = t_{WH}$)	$V_{DD} = 5.0V$		100	200	ns
	$V_{DD} = 10V$		45	100	ns
	$V_{DD} = 15V$		35	70	ns
t_{RCL}, t_{FCL} Clock Rise and Fall Time ($t_{RCL} = t_{FCL}$)	$V_{DD} = 5.0V$			15	μs
	$V_{DD} = 10V$			15	μs
	$V_{DD} = 15V$			15	μs
t_{SU} Minimum Set-up Time	$V_{DD} = 5.0V$		50	100	ns
	$V_{DD} = 10V$		25	50	ns
	$V_{DD} = 15V$		20	40	ns
t_H Minimum Hold Time	$V_{DD} = 5.0V$		55	110	ns
	$V_{DD} = 10V$		35	70	ns
	$V_{DD} = 15V$		30	60	ns
f_{CL} Maximum Clock Frequency	$V_{DD} = 5.0V$	2.5	5.0		MHz
	$V_{DD} = 10V$		5.0	12	MHz
	$V_{DD} = 15V$		7.0	16	MHz
C_L Input Capacitance	Data Input		5.0		pF
	CLK Input		7.5		pF

Note 1: "Absolute Maximum Ratings" are those values beyond which the safety of the device cannot be guaranteed; they are not meant to imply that the devices should be operated at these limits. The tables of "Recommended Operating Conditions" and "Electrical Characteristics" provide conditions for actual device operation.

Note 2: $V_{SS} = 0V$ unless otherwise specified.

Switching Time Waveforms

