

CD4028BM/CD4028BC BCD-to-Decimal Decoder

General Description

The CD4028BM/CD4028BC is a BCD-to-decimal or binary-to-octal decoder consisting of 4 inputs, decoding logic gates, and 10 output buffers. A BCD code applied to the 4 inputs, A, B, C, and D, results in a high level at the selected 1-of-10 decimal decoded outputs. Similarly, a 3-bit binary code applied to inputs A, B, and C is decoded in octal at outputs 0-7. A high level signal at the D input inhibits octal decoding and causes outputs 0-7 to go low.

All inputs are protected against static discharge damage by diode clamps to V_{DD} and V_{SS} .

Features

- Wide supply voltage range 3.0V to 15V
- High noise immunity 0.45 V_{DD} (typ.)
- Low power TTL compatibility fan out of 2 driving 74L or 1 driving 74LS
- Low power
- Glitch free outputs
- "Positive logic" on inputs and outputs

Applications

- Code conversion
- Address decoding
- Indicator-tube decoder

Logic and Connection Diagrams

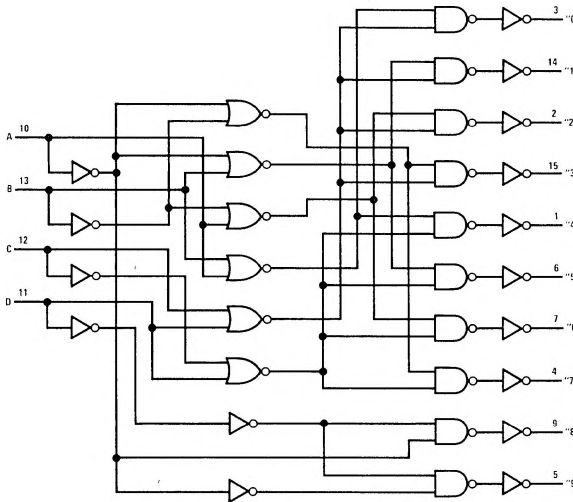

Dual-In-Line and Flat Package

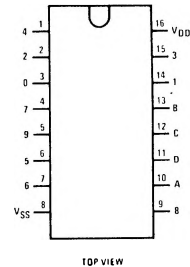

Truth Table

D	C	B	A	0	1	2	3	4	5	6	7	8	9
0	0	0	0	1	0	0	0	0	0	0	0	0	0
0	0	0	1	0	1	0	0	0	0	0	0	0	0
0	0	1	0	0	0	1	0	0	0	0	0	0	0
0	0	1	1	0	0	0	0	1	0	0	0	0	0
0	1	0	0	0	0	0	0	0	1	0	0	0	0
0	1	0	1	0	0	0	0	0	0	1	0	0	0
0	1	1	0	0	0	0	0	0	0	0	1	0	0
0	1	1	1	0	0	0	0	0	0	0	0	1	0
1	0	0	0	0	0	0	0	0	0	0	0	0	1
1	0	0	1	0	0	0	0	0	0	0	0	0	0
1	0	1	0	0	0	0	0	0	0	0	0	0	0
1	0	1	1	0	0	0	0	0	0	0	0	0	0
1	1	0	0	0	0	0	0	0	0	0	0	0	0
1	1	0	1	0	0	0	0	0	0	0	0	0	0
1	1	1	0	0	0	0	0	0	0	0	0	0	0
1	1	1	1	0	0	0	0	0	0	0	0	0	0

BCD States

Extraordinary States

1 = High level
0 = Low level

Absolute Maximum Ratings (Note 1)

(Notes 1 and 2)

V _{DD} Supply Voltage	-0.5 to +18V
V _{IN} Input Voltage	-0.5 to V _{DD} + 0.5V
T _S Storage Temperature Range	-65°C to +150°C
P _D Package Dissipation	500 mW
T _L Lead Temperature (Soldering, 10 seconds)	300°C

Recommended Operating Conditions

(Note 2)

V _{DD} Supply Voltage	3 to 15V
V _{IN} Input Voltage	0 to V _{DD} V
T _A Operating Temperature Range	-55°C to +125°C
CD4028BM	-55°C to +125°C
CD4028BC	-40°C to +85°C

DC Electrical Characteristics CD4028BC (Note 2)

PARAMETER	CONDITIONS	-55°C		25°C			125°C		UNITS
		MIN	MAX	MIN	TYP	MAX	MIN	MAX	
I _{DD} Quiescent Device Current	V _{DD} = 5V		5		0.01	5		150	μA
	V _{DD} = 10V		10		0.01	10		300	μA
	V _{DD} = 15V		20		0.02	20		600	μA
V _{OL} Low Level Output Voltage	I _O < 1 μA, V _{IL} = 0V, V _{IH} = V _{DD}								
	V _{DD} = 5V		0.05		0	0.05		0.05	V
	V _{DD} = 10V		0.05		0	0.05		0.05	V
V _{OH} High Level Output Voltage	I _O < 1 μA, V _{IL} = 0V, V _{IH} = V _{DD}								
	V _{DD} = 5V	4.95		4.95	5		4.95		V
	V _{DD} = 10V	9.95		9.95	10		9.95		V
V _{IL} Low Level Input Voltage	I _O < 1 μA								
	V _{DD} = 5V, V _O = 0.5V or 4.5V		1.5		2.25	1.5		1.5	V
	V _{DD} = 10V, V _O = 1V or 9V		3.0		4.5	3.0		3.0	V
V _{IH} High Level Input Voltage	I _O < 1 μA								
	V _{DD} = 5V, V _O = 0.5V or 4.5V	3.5		3.5	2.75		3.5		V
	V _{DD} = 10V, V _O = 1V or 9V	7.0		7.0	5.5		7.0		V
I _{OL} Low Level Output Current	V _{IL} = 0V, V _{IH} = V _{DD}								
	V _{DD} = 5V, V _O = 0.4V	0.64		0.51	1.0		0.36		mA
	V _{DD} = 10V, V _O = 0.5V	1.6		1.3	2.6		0.9		mA
I _{OH} High Level Output Current	V _{IL} = 0V, V _{IH} = V _{DD}								
	V _{DD} = 5V, V _O = 4.6V	-0.25		-0.2	-0.4		-0.14		mA
	V _{DD} = 10V, V _O = 9.5V	-0.62		-0.5	-1.0		-0.35		mA
I _{IN} Input Current	V _{DD} = 15V, V _{IN} = 0V		-0.1		-10 ⁻⁵	-0.1		-1.0	μA
	V _{DD} = 15V, V _{IN} = 15V		0.1		10 ⁻⁵	0.1		1.0	μA

DC Electrical Characteristics CD4028BC (Note 2)

PARAMETER	CONDITIONS	-40°C		25°C			85°C		UNITS
		MIN	MAX	MIN	TYP	MAX	MIN	MAX	
I _{DD} Quiescent Device Current	V _{DD} = 5V		20		0.01	20		150	μA
	V _{DD} = 10V		40		0.01	40		300	μA
	V _{DD} = 15V		80		0.02	80		600	μA
V _{OL} Low Level Output Voltage	I _O < 1 μA, V _{IL} = 0V, V _{IH} = V _{DD}								
	V _{DD} = 5V		0.05		0	0.05		0.05	V
	V _{DD} = 10V		0.05		0	0.05		0.05	V
V _{OH} High Level Output Voltage	I _O < 1 μA, V _{IL} = 0V, V _{IH} = V _{DD}								
	V _{DD} = 5V	4.95		4.95	5		4.95		V
	V _{DD} = 10V	9.95		9.95	10		9.95		V
V _{IL} Low Level Input Voltage	I _O < 1 μA								
	V _{DD} = 5V, V _O = 0.5V or 4.5V		1.5		2.25	1.5		1.5	V
	V _{DD} = 10V, V _O = 1V or 9V		3.0		4.5	3.0		3.0	V
I _{IN} Input Current	V _{DD} = 15V, V _{IN} = 0V		-0.1		-10 ⁻⁵	-0.1		-1.0	μA
	V _{DD} = 15V, V _{IN} = 15V		0.1		10 ⁻⁵	0.1		1.0	μA

DC Electrical Characteristics (Cont'd.) CD4028BC (Note 2)

PARAMETER	CONDITIONS	-40°C		25°C			85°C		UNITS
		MIN	MAX	MIN	TYP	MAX	MIN	MAX	
V_{IH} High Level Input Voltage	$ I_{OI} < 1 \mu A$								
	$V_{DD} = 5V, V_O = 0.5V \text{ or } 4.5V$	3.5		3.5			3.5		V
	$V_{DD} = 10V, V_O = 1V \text{ or } 9V$	7.0		7.0			7.0		V
	$V_{DD} = 15V, V_O = 1.5V \text{ or } 13.5V$	11.0		11.0			11.0		V
I_{OL} Low Level Output Current	$V_{IH} = V_{DD}, V_{IL} = 0V$								
	$V_{DD} = 5V, V_O = 0.4V$	0.52		0.44	0.88		0.36		mA
	$V_{DD} = 10V, V_O = 0.5V$	1.3		1.1	2.2		0.9		mA
	$V_{DD} = 15V, V_O = 1.5V$	3.6		3.0	6.0		2.4		mA
I_{OH} High Level Output Current	$V_{IH} = V_{DD}, V_{IL} = 0V$								
	$V_{DD} = 5V, V_O = 4.6V$	-0.2		-0.16	-0.32		-0.12		mA
	$V_{DD} = 10V, V_O = 9.5V$	-0.5		-0.4	-0.8		-0.3		mA
	$V_{DD} = 15V, V_O = 13.5V$	-1.4		-1.2	-2.4		-1.0		mA
I_{IN} Input Current	$V_{DD} = 15V, V_{IN} = 0V$	-0.3			-0.3			-1.0	μA
	$V_{DD} = 15V, V_{IN} = 15V$	0.3			0.3			1.0	μA

AC Electrical Characteristics $T_A = 25^\circ C, C_L = 50 \text{ pF}, R_L = 200 \text{ k}, \text{ Input } t_r = t_f = 20 \text{ ns},$ unless otherwise specified

PARAMETER	CONDITIONS	MIN	TYP	MAX	UNITS
t_{PHL} or t_{PLH} Propagation Delay	$V_{CC} = 5V$		240	480	ns
	$V_{CC} = 10V$		100	200	ns
	$V_{CC} = 15V$		70	140	ns
t_{THL} or t_{TLH} Transition Time	$V_{CC} = 5V$		175	350	ns
	$V_{CC} = 10V$		75	150	ns
	$V_{CC} = 15V$		60	110	ns
C_{IN} Input Capacitance	Any Input		5	7.5	pF

Note 1: "Absolute Maximum Ratings" are those values beyond which the safety of the device cannot be guaranteed; they are not meant to imply that the devices should be operated at these limits. The table of "Recommended Operating Conditions" and "Electrical Characteristics" provides conditions for actual device operation.

Note 2: $V_{SS} = 0V$ unless otherwise specified.

Switching Time Waveforms

