

Features

- **Very Low Power Consumption:**
70 μ W (typ.) at VCO fo = 10kHz, VDD = 5V
- **Operating Frequency Range Up to 1.4 MHz (typ.) at VDD = 10V, RI = 5k Ω**
- **Low Frequency Drift: 0.04%/ $^{\circ}$ C (typ.) at VDD = 10V**
- **Choice of Two Phase Comparators:**
 - Exclusive-OR Network (I)
 - Edge-Controlled Memory Network with Phase-Pulse Output for Lock Indication (II)
- **High VCO Linearity: <1% (typ.) at VDD = 10V**
- **VCO Inhibit Control for ON-OFF Keying and Ultra-Low Standby Power Consumption**
- **Source-Follower Output of VCO Control Input (Demod. Output)**
- **Zener Diode to Assist Supply Regulation**
- **Standardize, Symmetrical Output Characteristics**
- **100% Tested for Quiescent Current at 20V**
- **5V, 10V and 15V Parametric Ratings**
- **Meets All Requirements of JEDEC Tentative Standard No. 13B, "Standard Specifications for Description of 'B' Series CMOS Devices"**

Applications

- FM Demodulator and Modulator
- Frequency Synthesis and Multiplication
- Frequency Discriminator
- Data Synchronization
- Voltage-to-Frequency Conversion
- Tone Decoding
- FSK - Modems
- Signal Conditioning

Description

CD4046BMS CMOS Micropower Phase-Locked Loop (PLL) consists of a low power linear voltage-controlled oscillator (VCO) and two different phase comparators having a common signal-input amplifier and a common comparator input. A 5.2V zener diode is provided for supply regulation if necessary.

The CD4046BMS is supplied in these 16-lead outline packages:

Braze Seal DIP H4W
Frit Seal DIP H1F
Ceramic Flatpack H6W

VCO Section

The VCO requires one external capacitor C1 and one or two external resistors (R1 or R1 and R2). Resistor R1 and capacitor C1 determine the frequency range of the VCO and resistor R2 enables the VCO to have a frequency offset if required. The high input impedance ($10^{12}\Omega$) of the VCO simplifies the design of low pass filters by permitting the designer a wide choice of resistor-to-capacitor ratios. In order not to load the low-pass filter, a source-follower output of the VCO input voltage is provided at terminal 10 (DEMODULATED OUTPUT). If this terminal is used, a load resistor (RS) of 10k Ω or more should be connected from this terminal to VSS. If unused this terminal should be left open. The VCO can be connected either directly or through frequency dividers to the comparator input of the phase comparators. A full CMOS logic swing is available at the output of the VCO and allows direct coupling to CMOS frequency dividers such as the Intersil CD4024, CD4018, CD4020, CD4029, and CD4050. One or more CD4018 (Preset Table Divide-By-N Counter) or CD4029 (Presettable Up/Down Counter) or CD4029 (Presettable Divide-by-N Counter) or CD4029 (Presettable Up/Down Counter), or CD4059A (Programmable Divide-by "N" Counter), together with the CD4046BMS (Phase-Locked Loop) can be used to build a micropower low-frequency synthesizer. A logic 0 on the INHIBIT input "enables" the VCO and the source follower, while a logic 1 "turns off" both to minimize stand-by power consumption.

Pinout

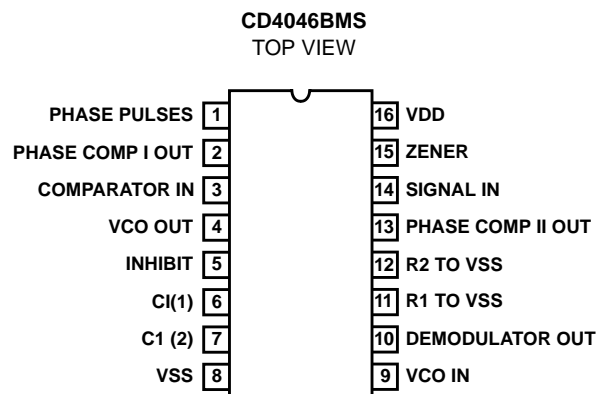

Phase Comparators

The phase-comparator signal input (terminal 14) can be direct-coupled provided the signal swing is within CMOS logic levels (logic "0" $\leq 30\%$ (VDD-VSS), logic "1" $\geq 70\%$ (VDD - VSS)]. For smaller swings the signal must be capacitively coupled to the self-biasing amplifier at the signal input.

Phase-comparator I is an exclusive -OR network; it operates analogously to an overdriven balanced mixer. To maximize the lock range, the signal and comparator-input frequencies must have a 50% duty cycle. With no signal or noise on the signal input, this phase comparator has an average output voltage equal to VDD/2. The low-pass filter connected to the output of phase-comparator I supplies the averaged voltage to the VCO input, and causes the VCO to oscillate at the center frequency (f_0).

The frequency range of input signals on which the PLL will lock if it was initially out of lock is defined as the frequency capture range ($2fc$).

The frequency range of input signals on which the loop will stay locked if it was initially in lock is defined as the frequency lock range ($2fL$). The capture range is \leq the lock range.

With phase-comparator I the range of frequencies over which the PLL can acquire lock (capture range) is dependent on the low-pass-filter characteristics, and can be made as large as the lock range. Phase-comparator I enables a PLL system to remain in lock in spite of high amounts of noise in the input signal.

One characteristic of this type of phase comparator is that it may lock onto input frequencies that are close to harmonics of the VCO center-frequency. A second characteristic is that the phase angle between the signal and the comparator input varies between 0° and 180° , and is 90° at the center frequency. Figure 1 shows the typical, triangular, phase-to-output response characteristic of phase comparator I. Typical waveforms for a CMOS phase-locked-loop employing phase comparator I in locked condition of f_0 is shown in Figure 2.

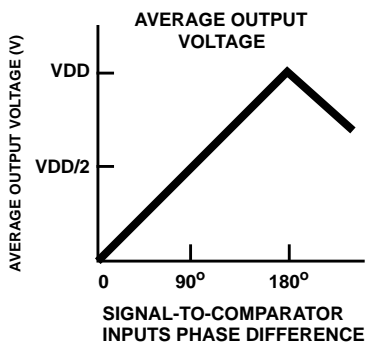

FIGURE 1. PHASE-COMPARATOR I CHARACTERISTICS AT LOW-PASS FILTER OUTPUT

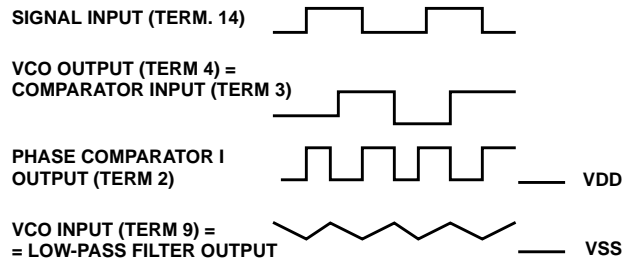

FIGURE 2. TYPICAL WAVEFORMS FOR CMOS PHASE-LOCKED LOOP EMPLOYING PHASE COMPARATOR IN LOCKED CONDITION OF f_0 .

Phase comparator II is an edge-controlled digital memory network. It consists of four flip-flop stages, control gating, and a three-state output circuit comprising p- and n- type drivers having a common output node. When the p-MOS or n-MOS drivers are ON they pull the output up to VDD or down to VSS, respectively. This type of phase comparator acts only on the positive edges of the signal and comparator inputs. The duty cycles of the signal and comparator inputs are not important since positive transitions control the PLL system utilizing this type of comparator. If the signal-input frequency is higher than the comparator-input frequency, the p-type output driver is maintained ON most of the time, and both the n and p drivers OFF (3state) the remainder of the time. If the signal-input frequency is lower than the comparator-input frequency, the n-type output driver is maintained ON most of the time, and both the n and p drivers OFF (3 state) the remainder of the time. If the signal and comparator input frequencies are the same, but the signal input lags the comparator input in phase, the n-type output driver is maintained ON for a time corresponding to the phase differences. If the signal and comparator-input frequencies are the same, but the comparator input lags the signal in phase, the p-type output driver is maintained ON for a time corresponding to the phase difference. Subsequently, the capacitor voltage of the low-pass filter connected to this phase comparator is adjusted until the signal and comparator inputs are equal in both phase and frequency. At this stable point both p- and n-type output drivers remain OFF and thus the phase comparator output becomes an open circuit and holds the voltage on the capacitor of the low-pass filter constant. Moreover the signal at the "phase pulses" output is a high level which can be used for indicating a locked condition. Thus, for phase comparator II, no phase difference exists between signal and comparator input over the full VCO frequency range. Moreover, the power dissipation due to the low-pass filter is reduced when this type of phase comparator is used because both the p- and n-type output drivers are OFF for most of the signal input cycle. It should be noted that the PLL lock range for this type of phase comparator is equal to the capture range, independent of the low-pass filter. With no signal present at the signal input, the VCO is adjusted to its lowest frequency for phase comparator II. Figure 15 shows typical waveforms for a CMOS PLL employing phase comparator II in a locked condition.

Specifications CD4046BMS

Absolute Maximum Ratings

DC Supply Voltage Range, (VDD)	-0.5V to +20V (Voltage Referenced to VSS Terminals)
Input Voltage Range, All Inputs	-0.5V to VDD +0.5V
DC Input Current, Any One Input	±10mA
Operating Temperature Range	-55°C to +125°C Package Types D, F, K, H
Storage Temperature Range (TSTG)	-65°C to +150°C
Lead Temperature (During Soldering)	+265°C At Distance 1/16 ± 1/32 Inch (1.59mm ± 0.79mm) from case for 10s Maximum

Reliability Information

Thermal Resistance	θ_{ja}	θ_{jc}
Ceramic DIP and FRIT Package	80°C/W	20°C/W
Flatpack Package	70°C/W	20°C/W
Maximum Package Power Dissipation (PD) at +125°C		
For TA = -55°C to +100°C (Package Type D, F, K)	500mW	
For TA = +100°C to +125°C (Package Type D, F, K)	Derate Linearity at 12mW/°C to 200mW	
Device Dissipation per Output Transistor	100mW	
For TA = Full Package Temperature Range (All Package Types)		
Junction Temperature	+175°C	

TABLE 1. DC ELECTRICAL PERFORMANCE CHARACTERISTICS

PARAMETER	SYMBOL	CONDITIONS (NOTE 1)	GROUP A SUBGROUPS	TEMPERATURE	LIMITS		UNITS	
					MIN	MAX		
Supply Current	IDD	VDD = 20V, VIN = VDD or GND	1	+25°C	-	10	μA	
			2	+125°C	-	1000	μA	
		VDD = 18V, VIN = VDD or GND	3	-55°C	-	10	μA	
Input Leakage Current	IIL	VIN = VDD or GND	VDD = 20	1	+25°C	-100	-	nA
				2	+125°C	-1000	-	nA
			VDD = 18V	3	-55°C	-100	-	nA
Input Leakage Current	IIH	VIN = VDD or GND	VDD = 20	1	+25°C	-	100	nA
				2	+125°C	-	1000	nA
			VDD = 18V	3	-55°C	-	100	nA
Output Voltage	VOL15	VDD = 15V, No Load	1, 2, 3	+25°C, +125°C, -55°C	-	50	mV	
Output Voltage	VOH15	VDD = 15V, No Load (Note 3)	1, 2, 3	+25°C, +125°C, -55°C	14.95	-	V	
Output Current (Sink)	IOL5	VDD = 5V, VOUT = 0.4V	1	+25°C	0.53	-	mA	
Output Current (Sink)	IOL10	VDD = 10V, VOUT = 0.5V	1	+25°C	1.4	-	mA	
Output Current (Sink)	IOL15	VDD = 15V, VOUT = 1.5V	1	+25°C	3.5	-	mA	
Output Current (Source)	IOH5A	VDD = 5V, VOUT = 4.6V	1	+25°C	-	-0.53	mA	
Output Current (Source)	IOH5B	VDD = 5V, VOUT = 2.5V	1	+25°C	-	-1.8	mA	
Output Current (Source)	IOH10	VDD = 10V, VOUT = 9.5V	1	+25°C	-	-1.4	mA	
Output Current (Source)	IOH15	VDD = 15V, VOUT = 13.5V	1	+25°C	-	-3.5	mA	
N Threshold Voltage	VNTH	VDD = 10V, ISS = -10μA	1	+25°C	-2.8	-0.7	V	
P Threshold Voltage	VPTH	VSS = 0V, IDD = 10μA	1	+25°C	0.7	2.8	V	
Functional	F	VDD = 2.8V, VIN = VDD or GND	7	+25°C	VOH > VDD/2	VOL < VDD/2	V	
		VDD = 20V, VIN = VDD or GND	7	+25°C				
		VDD = 18V, VIN = VDD or GND	8A	+125°C				
		VDD = 3V, VIN = VDD or GND	8B	-55°C				
Input Voltage Low (Note 2)	VIL	VDD = 5V, VOH > 4.5V, VOL < 0.5V	1, 2, 3	+25°C, +125°C, -55°C	-	1.5	V	
Input Voltage High (Note 2)	VIH	VDD = 5V, VOH > 4.5V, VOL < 0.5V	1, 2, 3	+25°C, +125°C, -55°C	3.5	-	V	
Input Voltage Low (Note 2)	VIL	VDD = 15V, VOH > 13.5V, VOL < 1.5V	1, 2, 3	+25°C, +125°C, -55°C	-	4	V	
Input Voltage High (Note 2)	VIH	VDD = 15V, VOH > 13.5V, VOL < 1.5V	1, 2, 3	+25°C, +125°C, -55°C	11	-	V	
3 State Leakage Current	IOZL	VIN = VDD or GND VOUT = 0V	VDD = 20V	1	+25°C	-100	-	nA
				2	+125°C	-1000	-	nA
			VDD = 18V	3	-55°C	-100	-	nA
3 State Leakage Current	IOZH	VIN = VDD or GND VOUT = VDD	VDD = 20V	1	+25°C	-	100	nA
				2	+125°C	-	1000	nA
			VDD = 18V	3	-55°C	-	100	nA

Specifications CD4046BMS

TABLE 1. DC ELECTRICAL PERFORMANCE CHARACTERISTICS (Continued)

PARAMETER	SYMBOL	CONDITIONS (NOTE 1)	GROUP A SUBGROUPS	TEMPERATURE	LIMITS		UNITS
					MIN	MAX	
Quiescent Leakage Phase Comparator (Bias Amp Leakage)	BIAS LKG	VDD = 20V, VIN = VDD or GND PIN 14 Open Pin 5 = VDD	1	+25°C	-	4	mA
			3	-55°C	-	4	mA
		VDD = 20V, VIN = VDD or GND PIN 14 = VSS or VDD Pin 5 = VDD	1	+25°C	-	160	μA
			3	-55°C	-	160	μA

NOTES: 1. All voltages referenced to device GND, 100% testing being implemented. 2. Go/No Go test with limits applied to inputs. 3. For accuracy, voltage is measured differentially to VDD. Limit is 0.050V max.

TABLE 2. AC ELECTRICAL PERFORMANCE CHARACTERISTICS

PARAMETER	SYMBOL	CONDITIONS (NOTE 1)	GROUP A SUBGROUPS	TEMPERATURE	LIMITS		UNITS
					MIN	MAX	
AC Coupled Signal Input Voltage Sensitivity (Peak to Peak)	VS	VDD = 5V, Input Frequency = 100kHz Sine Wave	9	+25°C	-	360	mV

NOTES:

- Go/No Go test with limits applied to inputs.

TABLE 3. ELECTRICAL PERFORMANCE CHARACTERISTICS

PARAMETER	SYMBOL	CONDITIONS	NOTES	TEMPERATURE	LIMITS		UNITS
					MIN	MAX	
Output Voltage	VOL	VDD = 5V, No Load	1, 2	+25°C, +125°C, -55°C	-	50	mV
Output Voltage	VOL	VDD = 10V, No Load	1, 2	+25°C, +125°C, -55°C	-	50	mV
Output Voltage	VOH	VDD = 5V, No Load	1, 2	+25°C, +125°C, -55°C	4.95	-	V
Output Voltage	VOH	VDD = 10V, No Load	1, 2	+25°C, +125°C, -55°C	9.95	-	V
Output Current (Sink)	IOL5	VDD = 5V, VOUT = 0.4V	1, 2	+125°C	0.36	-	mA
				-55°C	0.64	-	mA
Output Current (Sink)	IOL10	VDD = 10V, VOUT = 0.5V	1, 2	+125°C	0.9	-	mA
				-55°C	1.6	-	mA
Output Current (Sink)	IOL15	VDD = 15V, VOUT = 1.5V	1, 2	+125°C	2.4	-	mA
				-55°C	4.2	-	mA
Output Current (Source)	IOH5A	VDD = 5V, VOUT = 4.6V	1, 2	+125°C	-	-0.36	mA
				-55°C	-	-0.64	mA
Output Current (Source)	IOH5B	VDD = 5V, VOUT = 2.5V	1, 2	+125°C	-	-1.15	mA
				-55°C	-	-2.0	mA
Output Current (Source)	IOH10	VDD = 10V, VOUT = 9.5V	1, 2	+125°C	-	-0.9	mA
				-55°C	-	-1.6	mA
Output Current (Source)	IOH15	VDD = 15V, VOUT = 13.5V	1, 2	+125°C	-	-2.4	mA
				-55°C	-	-4.2	mA
Input Voltage Low	VIL	VDD = 10V, VOH > 9V, VOL < 1V	1, 2	+25°C, +125°C, -55°C	-	3	V
Input Voltage High	VIH	VDD = 10V, VOH > 9V, VOL < 1V	1, 2	+25°C, +125°C, -55°C	+7	-	V

Specifications CD4046BMS

TABLE 3. ELECTRICAL PERFORMANCE CHARACTERISTICS (Continued)

PARAMETER	SYMBOL	CONDITIONS	NOTES	TEMPERATURE	LIMITS		UNITS	
					MIN	MAX		
Quiescent Leakage Phase Comparator (Bias Amp Leakage)	BIAS LKG	VDD = 5 VIN = VDD or GND	Pin 14 Open Pin 5 = VDD	1, 2	+25°C/-55°C	-	0.2	mA
			Pin 14 = VSS or VDD Pin 5 = VDD	1, 2	+25°C/-55°C	-	20	μA
		VDD = 10 VIN = VDD or GND	Pin 14 Open Pin 5 = VDD	1, 2	+25°C/-55°C	-	1.0	mA
			Pin 14 = VSS or VDD Pin 5 = VDD	1, 2	+25°C/-55°C	-	40	μA
		VDD = 15 VIN = VDD or GND	Pin 14 Open Pin 5 = VDD	1, 2	+25°C/-55°C	-	1.5	mA
			Pin 14 = VSS or VDD Pin 5 = VDD	1, 2	+25°C/-55°C	-	80	μA
AC Coupled Signal Input Voltage Sensitivity (Peak to Peak)	VS	VDD = 10V, Input Frequency = 100kHz Sine Wave	1, 2	+25°C	-	660	mV	
		VDD = 15V, Input Frequency = 100kHz Sine Wave	1, 2	+25°C	-	1800	mV	

NOTES:

1. All voltages referenced to device GND.
2. The parameters listed on Table 3 are controlled via design or process and are not directly tested. These parameters are characterized on initial design release and upon design changes which would affect these characteristics.

TABLE 4. POST IRRADIATION ELECTRICAL PERFORMANCE CHARACTERISTICS

PARAMETER	SYMBOL	CONDITIONS	NOTES	TEMPERATURE	LIMITS		UNITS
					MIN	MAX	
Supply Current	IDD	VDD = 20V, VIN = VDD or GND	1, 4	+25°C	-	25	μA
N Threshold Voltage	VNTH	VDD = 10V, ISS = -10μA	1, 4	+25°C	-2.8	-0.2	V
N Threshold Voltage Delta	ΔVTN	VDD = 10V, ISS = -10μA	1, 4	+25°C	-	±1	V
P Threshold Voltage	VTP	VSS = 0V, IDD = 10μA	1, 4	+25°C	0.2	2.8	V
P Threshold Voltage Delta	ΔVTP	VSS = 0V, IDD = 10μA	1, 4	+25°C	-	±1	V
Functional	F	VDD = 18V, VIN = VDD or GND	1	+25°C	VOH > VDD/2	VOL < VDD/2	V
		VDD = 3V, VIN = VDD or GND					
AC Coupled Signal Input Voltage Sensitivity	VS	VDD = 5V Input Frequency = 100kHz Sine Wave	1, 2, 3	+25°C	-	1.35 x +25°C Limit	mV

NOTES:

1. All voltages referenced to device GND.
2. Go/No Go test with limits applied to inputs.
3. See Table 2 for +25°C limit.

TABLE 5. BURN-IN AND LIFE TEST DELTA PARAMETERS +25°C

PARAMETER	SYMBOL	DELTA LIMIT
Supply Current - MSI-2	IDD	± 1.0μA
Output Current (Sink)	IOL5	± 20% x Pre-Test Reading
Output Current (Source)	IOH5A	± 20% x Pre-Test Reading

Specifications CD4046BMS

TABLE 6. APPLICABLE SUBGROUPS

CONFORMANCE GROUP		METHOD	GROUP A SUBGROUPS	READ AND RECORD
Initial Test (Pre Burn-In)		100% 5004	1, 7, 9	IDD, IOL5, IOH5A
Interim Test 1 (Post Burn-In)		100% 5004	1, 7, 9	IDD, IOL5, IOH5A
Interim Test 2 (Post Burn-In)		100% 5004	1, 7, 9	IDD, IOL5, IOH5A
PDA (Note 1)		100% 5004	1, 7, 9, Deltas	
Interim Test 3 (Post Burn-In)		100% 5004	1, 7, 9	IDD, IOL5, IOH5A
PDA (Note 1)		100% 5004	1, 7, 9, Deltas	
Final Test		100% 5004	2, 3, 8A, 8B, 10, 11	
Group A		Sample 5005	1, 2, 3, 7, 8A, 8B, 9, 10, 11	
Group B	Subgroup B-5	Sample 5005	1, 2, 3, 7, 8A, 8B, 9, 10, 11, Deltas	Subgroups 1, 2, 3, 9, 10, 11
	Subgroup B-6	Sample 5005	1, 7, 9	
Group D		Sample 5005	1, 2, 3, 8A, 8B, 9	Subgroups 1, 2, 3

NOTE: 1. 5% Parametric, 3% Functional; Cumulative for Static 1 and 2.

TABLE 7. TOTAL DOSE IRRADIATION

CONFORMANCE GROUPS	METHOD	TEST		READ AND RECORD	
		PRE-IRRAD	POST-IRRAD	PRE-IRRAD	POST-IRRAD
Group E Subgroup 2	5005	1, 7, 9	Table 4	1, 9	Table 4

TABLE 8. BURN-IN AND IRRADIATION TEST CONNECTIONS

FUNCTION	OPEN	GROUND	VDD	9V ± 0.5V	OSCILLATOR	
					50kHz	25kHz
Static Burn-In 1 Note 1	1, 2, 4, 6, 7, 10, 11, 13, 15	3, 5, 8, 9, 14	12, 16			
Static Burn-In 2 Note 1	1, 2, 4, 6, 7, 10, 11, 13, 15	8	3, 5, 9, 12, 14, 16			
Dynamic Burn-In Note 1	1, 2, 4, 6, 7, 10, 11, 13, 15	8, 9	3, 5, 12, 16	2	14	-
Irradiation Note 2	1, 2, 4, 6, 7, 10, 11, 13, 15	8	3, 5, 9, 12, 14, 16			

NOTE:

- Each pin except VDD and GND will have a series resistor of $10K \pm 5\%$, $VDD = 18V \pm 0.5V$
- Each pin except VDD and GND will have a series resistor of $47K \pm 5\%$; Group E, Subgroup 2, sample size is 4 dice/wafer, 0 failures, $VDD = 10V \pm 0.5V$

CD4046BMS

Design Information

This information is a guide for approximating the values of external components for the CD4046BMS in a Phase-Locked-Loop system. The selected external components must be within the following ranges:

$$5k\Omega \leq R1, R2, RS \leq 1M\Omega$$

$$C1 \geq 100pF \text{ at } VDD \geq 5V$$

$$C1 \geq 50pF \text{ at } VDD \geq 10V$$

CHARACTERISTICS	PHASE COMPARATOR USED	DESIGN INFORMATION	
VCO Frequency	1	VCO Without Offset $R2 = \infty$	VCO With Offset
		<p style="text-align: center;">VCO INPUT VOLTAGE</p>	<p style="text-align: center;">VCO INPUT VOLTAGE</p>
	2	Same as for Number 1	
For Number Signal Input	1	VCO will adjust to center frequency, f_o	
	2	VCO will adjust to lowest operating frequency, f_{min}	
Frequency Lock Range, $2f_L$	1, 2	$2f_L = \text{full VCO frequency range}$	
	1, 2	$2f_L = f_{max} - f_{min}$	
Frequency Capture Range, $2f_C$	1	$\tau_1 = R3C2$	$2f_C \approx \frac{1}{\pi} \sqrt{\frac{2\pi f_L}{\tau_1}}$
Loop Filter Component Selection			For $2f_C$, see Ref. (2)
	2	$f_C = f_L$	
Phase Angle Between Signal and Comparator	1	90° at center frequency (f_o) approximating 0° and 180° at ends of lock range ($2f_L$)	
	2	Always 0° in lock	
Locks On Harmonic of Center Frequency	1	Yes	
	2	No	
Signal Input Noise Rejection	1	High	
	2	Low	

For further information, see

(1) F. Gardner, "Phase-Lock Techniques" John Wiley and Sons, New York 1966

(2) G. S. Moschytz, "Miniaturized RC Filters Using Phase-Locked Loop", BSTJ, May, 1965

Block Diagram

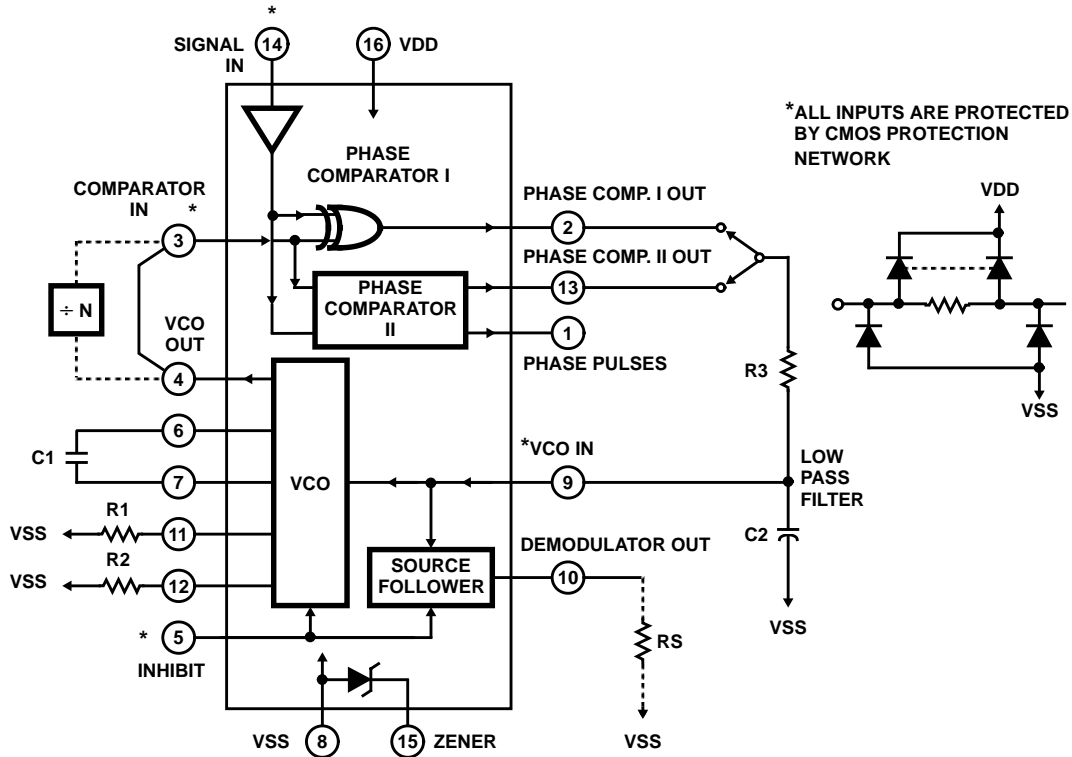

FIGURE 3. CMOS PHASE-LOCKED LOOP BLOCK DIAGRAM

Typical Performance Characteristics

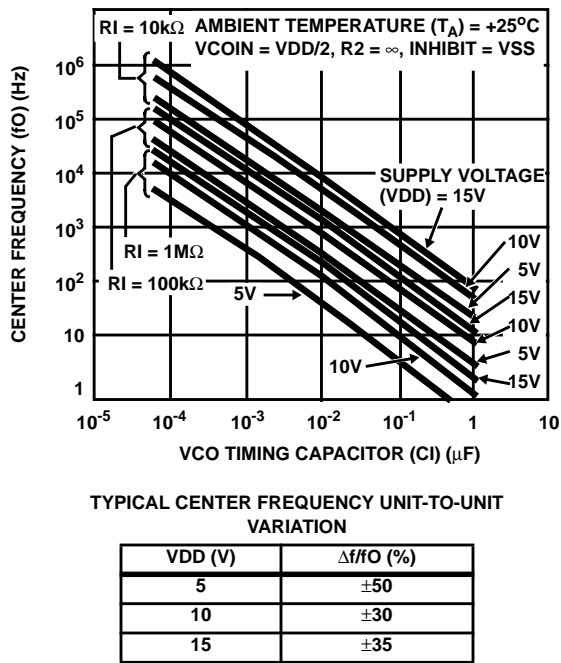

FIGURE 4. TYPICAL CENTER FREQUENCY AS A FUNCTION OF C_1 AND R_1 AT $V_{DD} = 5\text{V}$, 10V , AND 15V

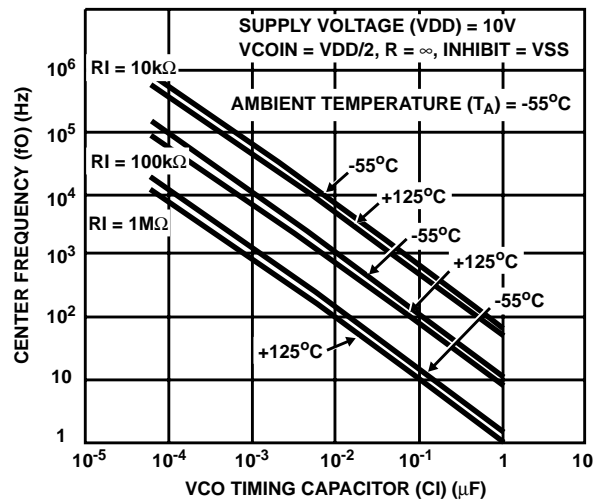

FIGURE 5. CENTER FREQUENCY AS A FUNCTION OF C_1 AND R_1 FOR AMBIENT TEMPERATURE OF -55°C TO $+125^\circ\text{C}$

Typical Performance Characteristics (Continued)

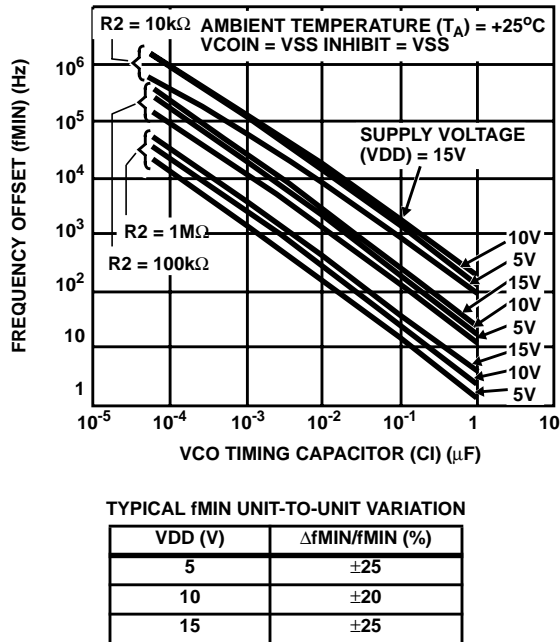

FIGURE 6. TYPICAL FREQUENCY OFFSET AS A FUNCTION OF C1 AND R2 FOR VDD = 5V, 10V, AND 15V

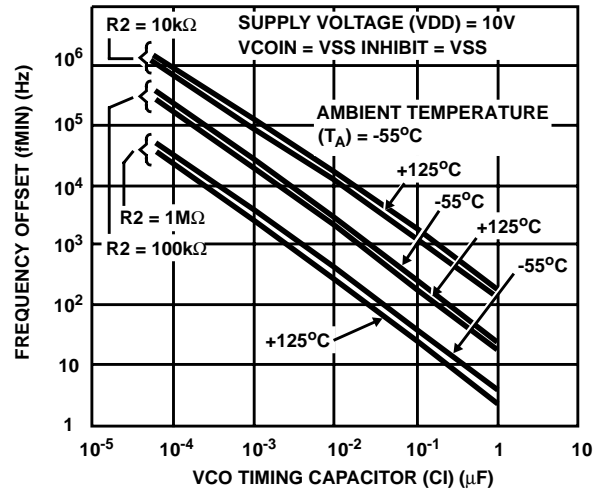

FIGURE 7. FREQUENCY OFFSET AS A FUNCTION OF C1 AND R2 FOR AMBIENT TEMPERATURES OF -55°C TO +125°C

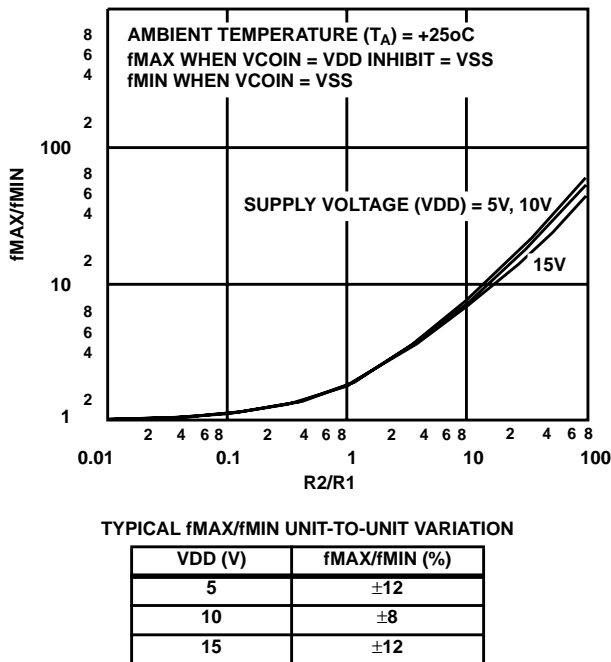

FIGURE 8. TYPICAL fMAX/fMIN AS A FUNCTION OF R2/R1

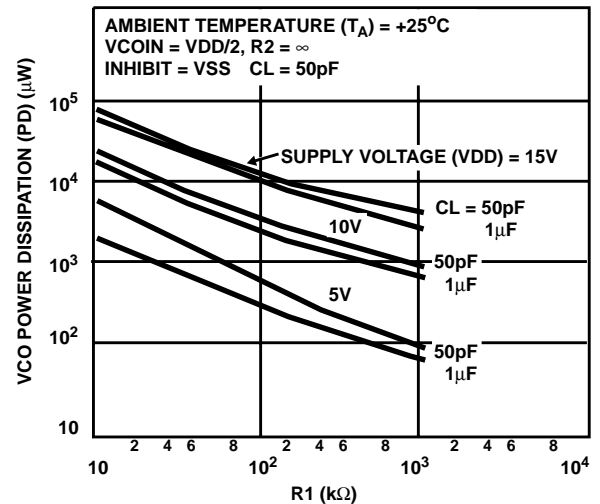

FIGURE 9. TYPICAL VCO POWER DISSIPATION AT CENTER FREQUENCY AS A FUNCTION OF R1

All Intersil semiconductor products are manufactured, assembled and tested under ISO9000 quality systems certification.

Intersil products are sold by description only. Intersil Corporation reserves the right to make changes in circuit design and/or specifications at any time without notice. Accordingly, the reader is cautioned to verify that data sheets are current before placing orders. Information furnished by Intersil is believed to be accurate and reliable. However, no responsibility is assumed by Intersil or its subsidiaries for its use; nor for any infringements of patents or other rights of third parties which may result from its use. No license is granted by implication or otherwise under any patent or patent rights of Intersil or its subsidiaries.

For information regarding Intersil Corporation and its products, see web site <http://www.intersil.com>

Typical Performance Characteristics (Continued)

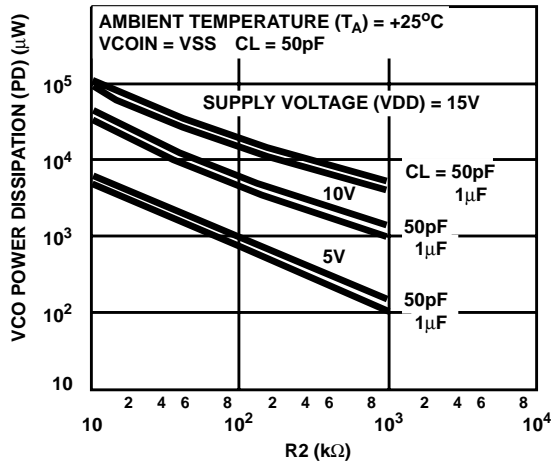

FIGURE 10. TYPICAL VCO POWER DISSIPATION AT f_{MIN} AS A FUNCTION OF R_2

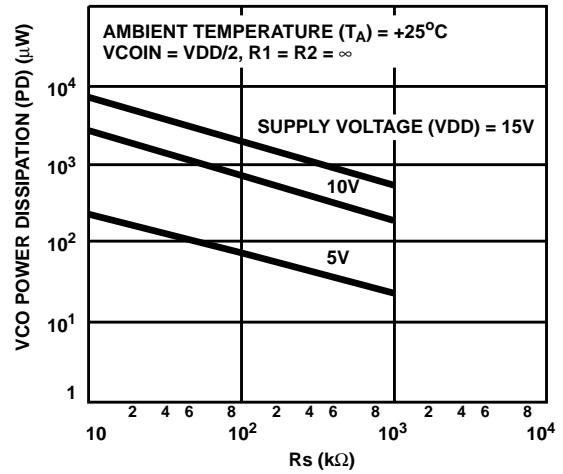

FIGURE 11. TYPICAL SOURCE FOLLOWER POWER DISSIPATION AS A FUNCTION OF R_S

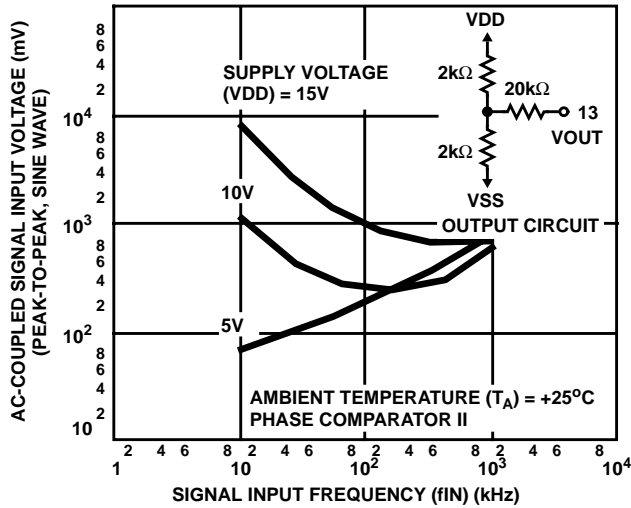

FIGURE 12. AC-COUPLED SIGNAL INPUT VOLTAGE AS A FUNCTION OF SIGNAL INPUT FREQUENCY

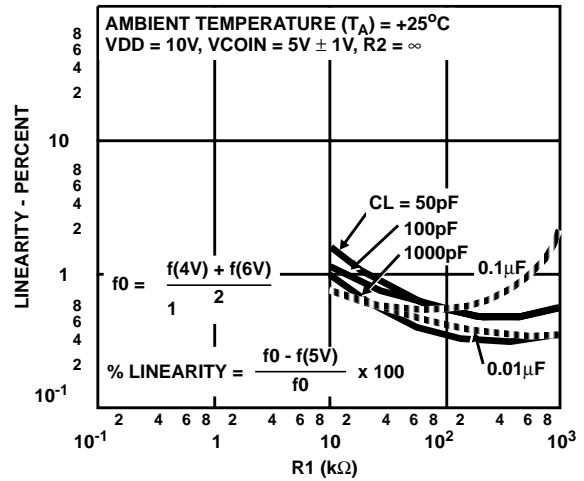

FIGURE 13. TYPICAL VCO LINEARITY AS A FUNCTION OF R_1 AND C_1 AT $V_{DD} = 10V$

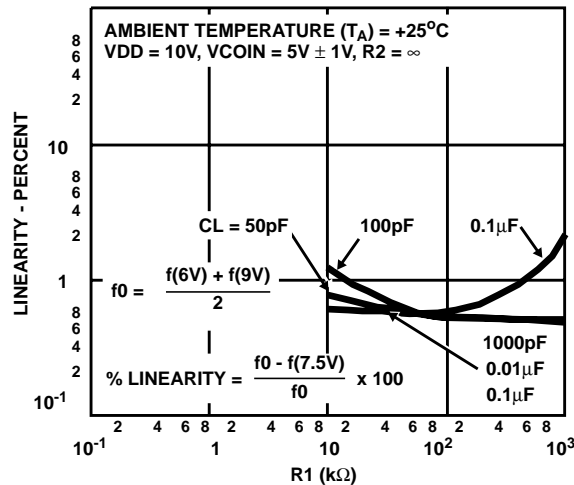
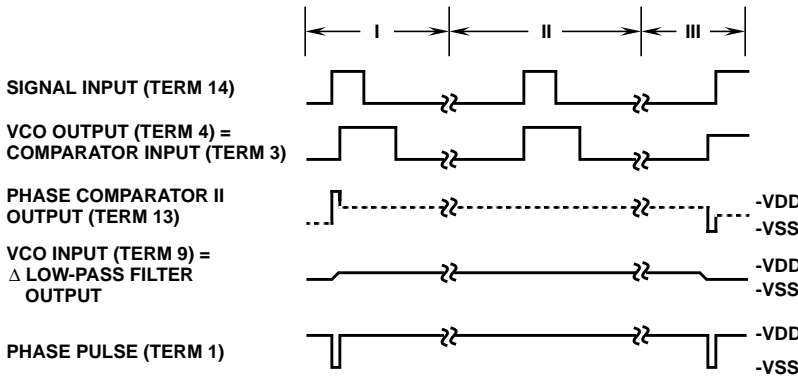

FIGURE 14. TYPICAL VCO LINEARITY AS A FUNCTION OF R_1 AND C_1 AT $V_{DD} = 15V$

CD4046BMS



NOTE: DASHED LINE IS AN OPEN CIRCUIT CONDITION (3RD STATE)

FIGURE 15. TYPICAL WAVEFORMS FOR COS/MOS PHASE-LOCKED LOOP EMPLOYING PHASE COMPARATOR II IN LOCKED CONDITION

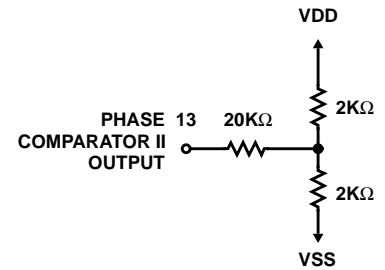
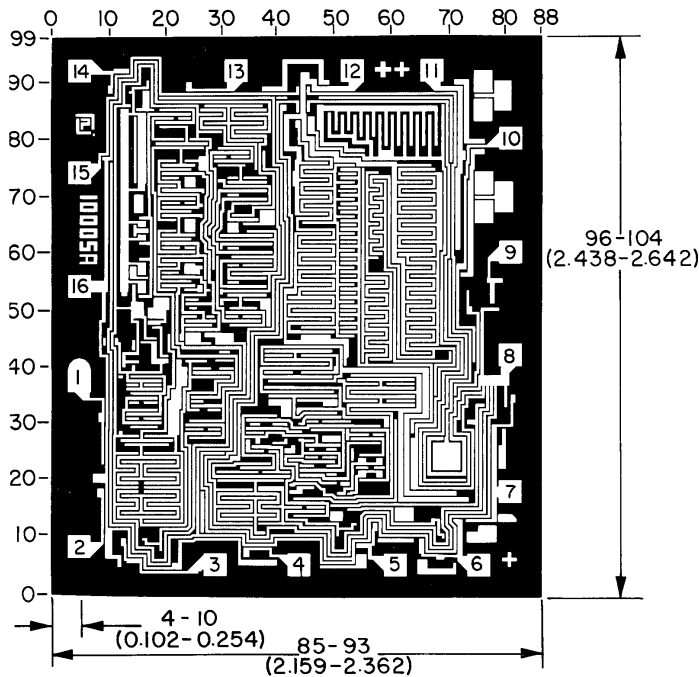

FIGURE 16. PHASE COMPARATOR II OUTPUT LOADING CIRCUIT

Chip Dimensions and Pad Layout



Dimensions in parentheses are in millimeters and are derived from the basic inch dimensions as indicated. Grid graduations are in mils (10^{-3} inch)

METALLIZATION: Thickness: $11\text{k}\text{\AA} - 14\text{k}\text{\AA}$, AL.

PASSIVATION: $10.4\text{k}\text{\AA} - 15.6\text{k}\text{\AA}$, Silane

BOND PADS: 0.004 inches X 0.004 inches MIN

DIE THICKNESS: 0.0198 inches - 0.0218 inches