

CS8311

Micropower 10 V, 100 mA Low Dropout Linear Regulator with RESET and ENABLE

The CS8311 is a precision 10 V micropower voltage regulator with very low quiescent current (100 μ A typ at 100 μ A load). The 10 V output is accurate within $\pm 4.0\%$ and supplies 100 mA of load current with a typical dropout voltage of only 400 mV. Microprocessor control logic includes an ENABLE input and an active RESET.

The active RESET circuit includes hysteresis, and operates correctly at an output voltage as low as 1.0 V. The RESET function is activated during the power up sequence or during normal operation if the output voltage drops outside the regulation limits by more than 1.0 V typ. The logic level compatible ENABLE input allows the user to put the regulator into a shutdown mode where it draws only 20 μ A typical of quiescent current.

The regulator is protected against reverse battery, short circuit, over voltage, and thermal overload conditions. The device can withstand load dump transients making it suitable for use in automotive environments.

Features

- 10 V $\pm 4.0\%$ Output
- Low 100 μ A Quiescent Current
- Active RESET
- ENABLE Input for ON/OFF and Active/Sleep Mode Control
- 100 mA Output Current Capability
- Fault Protection
 - +60 V Peak Transient Voltage
 - -15 V Reverse Voltage Short Circuit Thermal Overload
- Low Reverse Current (Output to Input)



ON Semiconductor™

<http://onsemi.com>



SO-8
D SUFFIX
CASE 751

PIN CONNECTIONS AND MARKING DIAGRAM

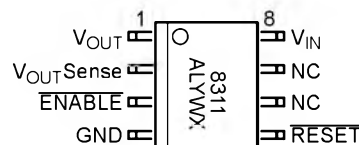

A = Assembly Location
WL, L = Wafer Lot
YY, Y = Year
WW, W = Work Week

ORDERING INFORMATION

Device	Package	Shipping
CS8311YD8	SO-8	95 Units/Rail
CS8311YDR8	SO-8	2500 Tape & Reel

CS8311

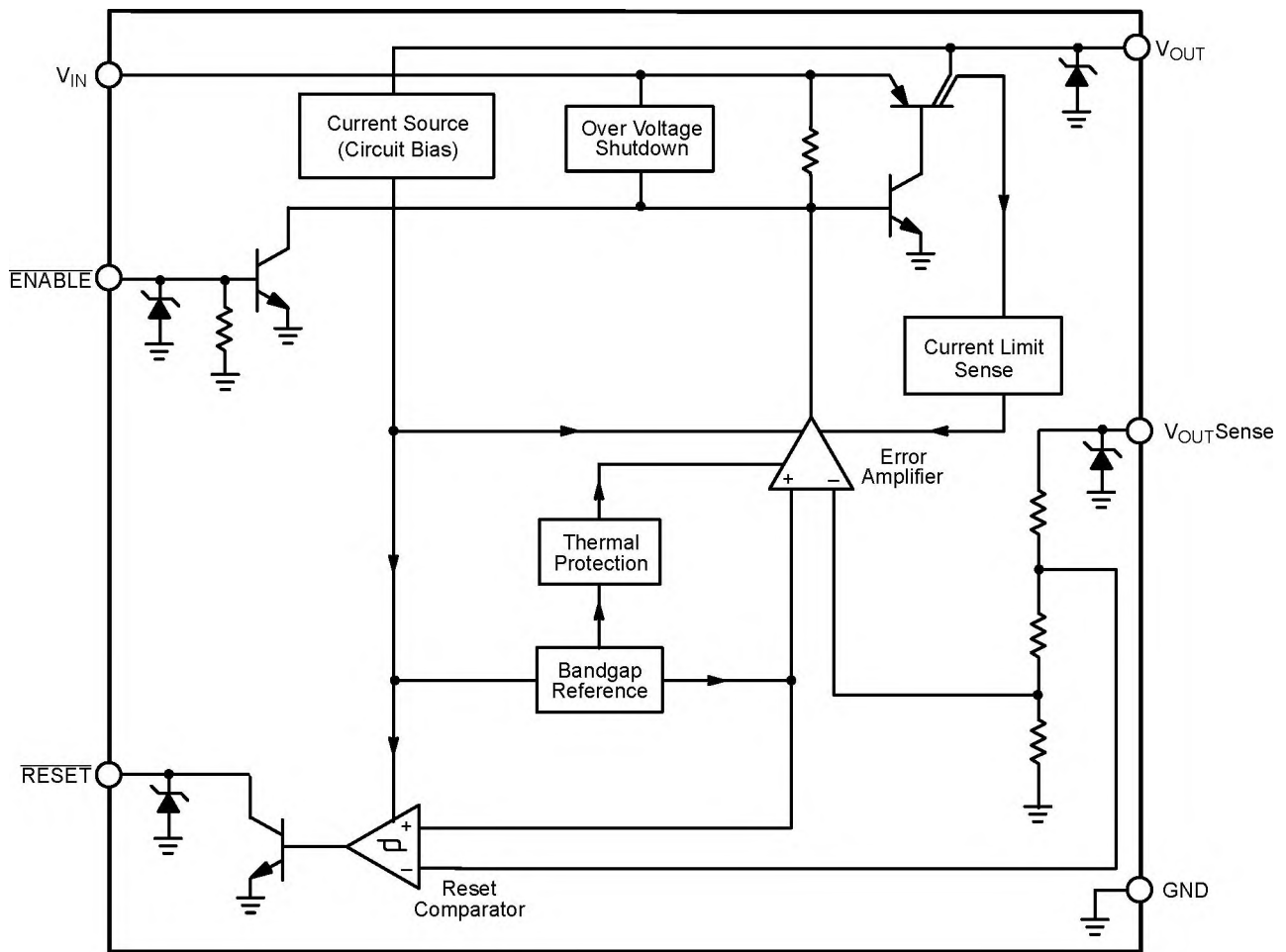

Figure 1. Block Diagram

ABSOLUTE MAXIMUM RATINGS*

Rating	Value	Unit
V_{IN}	38	V
Peak Transient Voltage (46 V Load Dump @ $V_{IN} = 14$ V)	60	V
ENABLE, RESET	-0.3 to +10.4	V
ESD Susceptibility (Human Body Model)	2.0	kV
Junction Temperature Range	-40 to +150	°C
Storage Temperature Range	-55 to +150	°C
Lead Temperature Soldering:	Reflow (SMD styles only) (Note 1)	230 peak

1. 60 second maximum above 183°C.

*The maximum package power dissipation must be observed.

CS8311

ELECTRICAL CHARACTERISTICS ($11\text{ V} \leq V_{IN} \leq 26\text{ V}$; $I_{OUT} = 1.0\text{ mA}$; $-40 \leq T_A \leq 125$, $-40^\circ\text{C} \leq T_J \leq 150^\circ\text{C}$; unless otherwise specified.)

Characteristic	Test Conditions	Min	Typ	Max	Unit
Output Stage					
Output Voltage, V_{OUT}	$11\text{ V} < V_{IN} < 26\text{ V}$, $100\ \mu\text{A} \leq I_{OUT} \leq 100\text{ mA}$	9.60	10.00	10.40	V
Dropout Voltage ($V_{IN} - V_{OUT}$)	$I_{OUT} = 100\text{ mA}$	–	400	600	mV
	$I_{OUT} = 100\ \mu\text{A}$	–	100	150	mV
Load Regulation	$V_{IN} = 14\text{ V}$, $100\ \mu\text{A} \leq I_{OUT} \leq 100\text{ mA}$	–	5.0	100	mV
Line Regulation	$11\text{ V} < V < 26\text{ V}$, $I_{OUT} = 1.0\text{ mA}$	–	5.0	100	mV
Quiescent Current, (I_Q) Active Mode	$I_{OUT} = 100\ \mu\text{A}$	–	100	250	μA
	$I_{OUT} = 50\text{ mA}$	–	4.0	6.0	mA
	$I_{OUT} = 100\text{ mA}$	–	12	20	mA
Quiescent Current, (I_Q) Sleep Mode	$V_{OUT} = \text{OFF}$, $V_{IN} = 12\text{ V}$, $\overline{V_{ENABLE}} = 2.0\text{ V}$	–	20	50	μA
Ripple Rejection	$14 \leq V_{IN} \leq 26\text{ V}$, $I_{OUT} = 100\text{ mA}$, $f = 120\text{ Hz}$	60	75	–	dB
Current Limit	–	105	200	–	mA
Short Circuit Output Current	$V_{OUT} = 0\text{ V}$	25	125	–	mA
Overshoot Shutdown	$V_{OUT} \leq 1.0\text{ V}$	30	34	38	V
Reverse Current	$V_{OUT} = 5.0\text{ V}$, $V_{IN} = 0\text{ V}$	–	100	250	μA

ENABLE Input (ENABLE)

Threshold High	(V_{OUT} OFF)	–	1.4	2.0	V
Threshold Low	(V_{OUT} ON)	0.6	1.4	–	V
Input Current	$\overline{V_{ENABLE}} = 2.4\text{ V}$	–	30	100	μA

Reset Function (RESET)

RESET Threshold High (V_{RH})	V_{OUT} Increasing	8.50	9.00	$V_{OUT} - 0.50$	V
RESET Threshold Low (V_{RL})	V_{OUT} Decreasing	8.30	8.90	$V_{OUT} - 0.45$	V
RESET Hysteresis	(High – Low)	50	100	200	mV
Reset Output Leakage RESET = High	$V_{OUT} \geq V_{RH}$	–	–	25	μA
Output Voltage Low (V_{RLO})	$\overline{R_{RESET}} = 10\text{ k}$, $1.0\text{ V} \leq V_{OUT} \leq V_{RL}$	–	0.1	0.4	V
Output Voltage Low (V_{RPEAK})	$\overline{R_{RESET}} = 10\text{ k}$, V_{OUT} , Power up, Power down	–	0.6	1.0	V

PACKAGE LEAD DESCRIPTION

PACKAGE LEAD #	LEAD SYMBOL	FUNCTION
SO-8		
1	V_{OUT}	10 V, $\pm 4.0\%$, 100 mA output.
2	V_{OUT} Sense	Kelvin connection which allows remote sensing of output voltage for improved regulation. If remote sensing is not required, connect to V_{OUT} .
3	ENABLE	Logic level switches output off when toggled HIGH.
4	GND	Ground. All GND leads must be connected to Ground.
5	RESET	Active reset (accurate to $V_{OUT} \geq 1.0\text{ V}$).
6, 7	NC	No connection.
8	V_{IN}	Input voltage.

CIRCUIT DESCRIPTION

VOLTAGE REFERENCE AND OUTPUT CIRCUITRY

Output Stage Protection

The output stage is protected against overvoltage, short circuit and thermal runaway conditions (Figure 2).

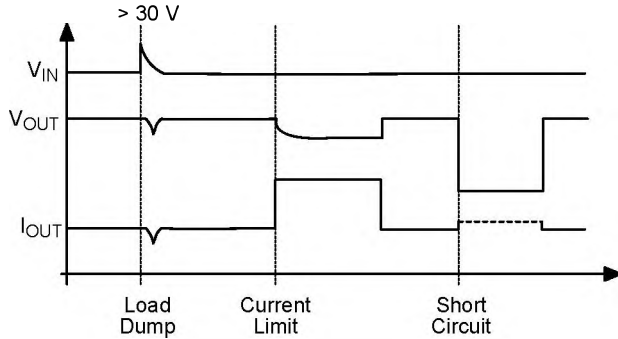

Figure 2. Typical Circuit Waveforms for Output Stage Protection

If the input voltage rises above 30 V (e.g. load dump), the output shuts down. This response protects the internal circuitry and enables the IC to survive unexpected voltage transients.

Should the junction temperature of the power device exceed 180°C (typ) the load current capability is reduced thereby preventing thermal overload. This thermal management function is an effective means to prevent die overheating since the load current is the principle heat source in the IC.

REGULATOR CONTROL FUNCTIONS

The CS8311 contains two microprocessor compatible control functions: $\overline{\text{ENABLE}}$ and $\overline{\text{RESET}}$ (Figure 3).

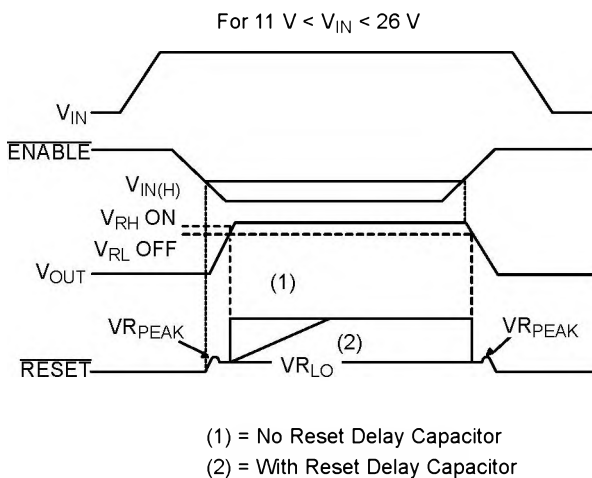

Figure 3. Circuit Waveform

ENABLE Function

The $\overline{\text{ENABLE}}$ function switches the output transistor ON and OFF. When the voltage on the $\overline{\text{ENABLE}}$ lead exceeds 1.4 V typ, the output pass transistor turns off, leaving a high impedance facing the load. The IC will remain in Sleep mode, drawing only 50 μA (max), until the voltage on this input drops below the $\overline{\text{ENABLE}}$ threshold.

RESET Function

A $\overline{\text{RESET}}$ signal (low voltage) is generated as the IC powers up until V_{OUT} is within 1.0 V of the regulated output voltage, or when V_{OUT} drops out of regulation, and is lower than 1.1 V below the regulated output voltage. A hysteresis of 50 mV is included in the function to minimize oscillations.

The $\overline{\text{RESET}}$ output is an open collector NPN transistor, controlled by a low voltage detection circuit. The circuit is functionally independent of the rest of the IC thereby guaranteeing that the $\overline{\text{RESET}}$ signal is valid for V_{OUT} as low as 1.0 V.

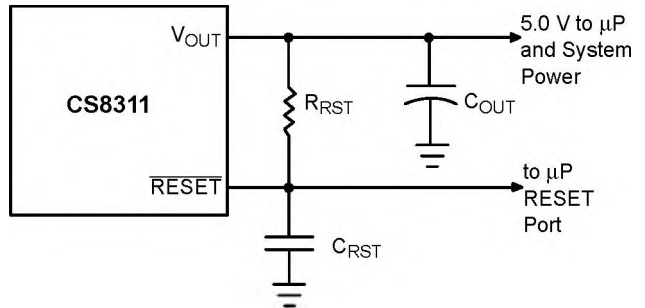

Figure 4. RC Network for $\overline{\text{RESET}}$ Delay

An external RC network on the lead (Figure 4) provides a sufficiently long delay for most microprocessor based applications. RC values can be chosen using the following formula:

$$R_{\text{TOT}}C_{\text{RST}} = \left[\frac{-t_{\text{Delay}}}{\ln\left(\frac{V_T - V_{\text{OUT}}}{V_{\text{RST}} - V_{\text{OUT}}}\right)} \right]$$

where:

- R_{RST} = $\overline{\text{RESET}}$ Delay resistor
- R_{IN} = μP port impedance
- R_{TOT} = R_{RST} in parallel with R_{IN}
- C_{RST} = $\overline{\text{RESET}}$ Delay capacitor
- t_{Delay} = desired delay time
- $V_{\text{RST}} = V_{\text{SAT}}$ of $\overline{\text{RESET}}$ lead (0.7 V @ turn - ON)
- V_T = $\overline{\text{RESET}}$ threshold.

APPLICATION NOTES

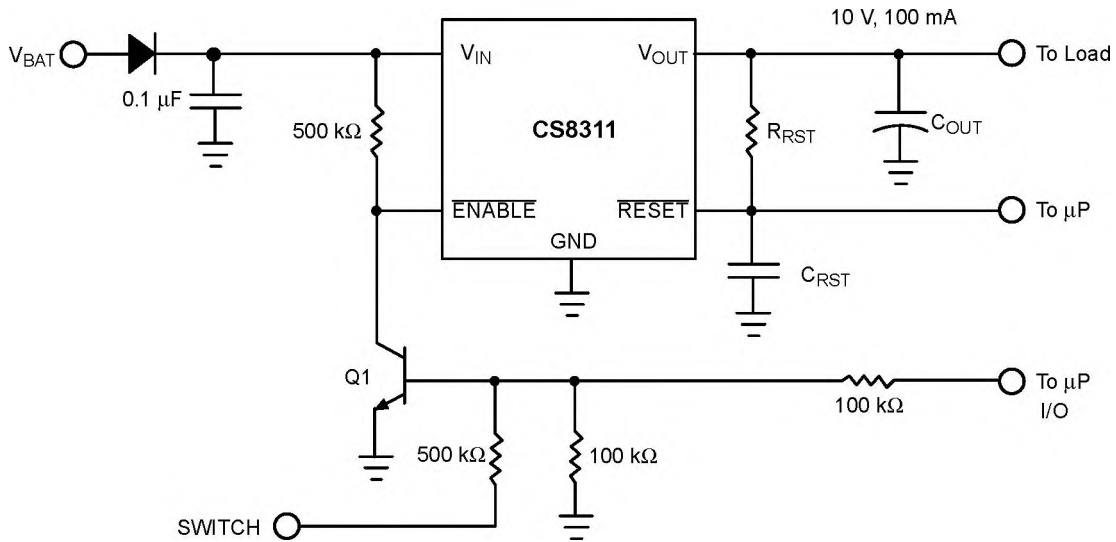

Figure 5. Microprocessor Control of CS8311 Using External Switching Transistor Q1

The circuit depicted in Figure 5 lets the system control its power source, the CS8311 regulator. A SWITC (potentially an I/O port on microprocessor) is used to drive the base of Q1. When Q1 is driven into saturation, the voltage on the $\overline{\text{ENABLE}}$ lead falls below its lower threshold. The regulator's output is enabled. When the drive current is removed, the voltage on the $\overline{\text{ENABLE}}$ lead rises, the output is switched off and the IC moves into Sleep mode where it draws 50 μA (max).

By coupling these two controls with the $\overline{\text{ENABLE}}$ lead, the system has added flexibility. Once the system is running, the state of the SWITC is irrelevant as long as the I/O port continues to drive Q1. The microprocessor can turn off its own power by withdrawing drive current, once the SWITC is open. This software control at the I/O port allows the microprocessor to finish key housekeeping functions before power is removed.

The logic options are summarized in Table 1.

Table 1. Logic Control of CS8311 Output

Microprocessor I/O Drive	Switch	$\overline{\text{ENABLE}}$	Output
ON	Closed	LOW	ON
	Open	LOW	ON
OFF	Closed	LOW	ON
	Open	HIGH	OFF

The I/O port of the microprocessor typically provides 50 μA to Q1. In automotive applications the SWITC is connected to the ignition switch.

STABILITY CONSIDERATIONS

The output or compensation capacitor helps determine three main characteristics of a linear regulator: start-up delay, load transient response and loop stability.

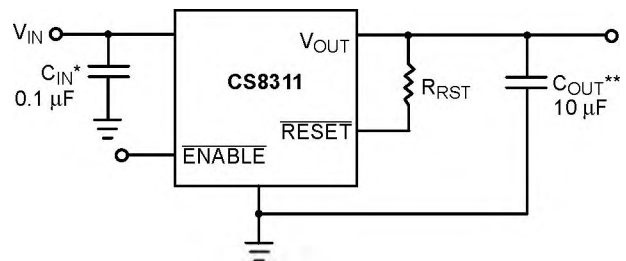

* C_{IN} required if regulator is located far from the power supply filter.

** C_{OUT} required for stability. Capacitor must operate at minimum temperature expected.

Figure 6. Test and Application Circuit Showing Output Compensation

The capacitor value and type should be based on cost, availability, size and temperature constraints. A tantalum or aluminum electrolytic capacitor is best, since a film or ceramic capacitor with almost zero ESR can cause instability. The aluminum electrolytic capacitor is the least expensive solution, but, if the circuit operates at low temperatures (-25°C to -40°C), both the value and ESR of the capacitor will vary considerably. The capacitor manufacturers data sheet usually provides this information.

The value for the output capacitor C_{OUT} shown in Figure 6 should work for most applications, however it is not necessarily the optimized solution.

To determine an acceptable value for C_{OUT} for a particular application, start with a tantalum capacitor of the recommended value and work towards a less expensive alternative part.

Step 1: Place the completed circuit with a tantalum capacitor of the recommended value in an environmental chamber at the lowest specified operating temperature and monitor the outputs with an oscilloscope. A decade box connected in series with the capacitor will simulate the higher ESR of an aluminum capacitor. Leave the decade box outside the chamber, the small resistance added by the longer leads is negligible.

Step 2: With the input voltage at its maximum value, increase the load current slowly from zero to full load while observing the output for any oscillations. If no oscillations are observed, the capacitor is large enough to ensure a stable design under steady state conditions.

Step 3: Increase the ESR of the capacitor from zero using the decade box and vary the load current until oscillations appear. Record the values of load current and ESR that cause the greatest oscillation. This represents the worst case load conditions for the regulator at low temperature.

Step 4: Maintain the worst case load conditions set in step 3 and vary the input voltage until the oscillations increase. This point represents the worst case input voltage conditions.

Step 5: If the capacitor is adequate, repeat steps 3 and 4 with the next smaller valued capacitor. A smaller capacitor will usually cost less and occupy less board space. If the output oscillates within the range of expected operating conditions, repeat steps 3 and 4 with the next larger standard capacitor value.

Step 6: Test the load transient response by switching in various loads at several frequencies to simulate its real working environment. Vary the ESR to reduce ringing.

Step 7: Raise the temperature to the highest specified operating temperature. Vary the load current as instructed in step 5 to test for any oscillations.

Once the minimum capacitor value with the maximum ESR is found, a safety factor should be added to allow for the tolerance of the capacitor and any variations in regulator performance. Most good quality aluminum electrolytic capacitors have a tolerance of $\pm 20\%$ so the minimum value found should be increased by at least 50% to allow for this tolerance plus the variation which will occur at low temperatures. The ESR of the capacitor should be less than 50% of the maximum allowable ESR found in step 3 above.

CALCULATING POWER DISSIPATION IN A SINGLE OUTPUT LINEAR REGULATOR

The maximum power dissipation for a single output regulator (Figure 7) is:

$$P_{D(max)} = |V_{IN(max)} - V_{OUT(min)}|I_{OUT(max)} + V_{IN(max)}I_Q \quad (1)$$

where:

$V_{IN(max)}$ is the maximum input voltage.

$V_{OUT(min)}$ is the minimum output voltage.

$I_{OUT(max)}$ is the maximum output current for the application, and

I_Q is the quiescent current the regulator consumes at $I_{OUT(max)}$.

Once the value of $P_{D(max)}$ is known, the maximum permissible value of $R_{\theta JA}$ can be calculated:

$$R_{\theta JA} = \frac{150^\circ C - T_A}{P_D} \quad (2)$$

The value of $R_{\theta JA}$ can then be compared with those in the package section of the data sheet. Those packages with $R_{\theta JA}$'s less than the calculated value in equation 2 will keep the die temperature below $150^\circ C$.

In some cases, none of the packages will be sufficient to dissipate the heat generated by the IC, and an external heatsink will be required.

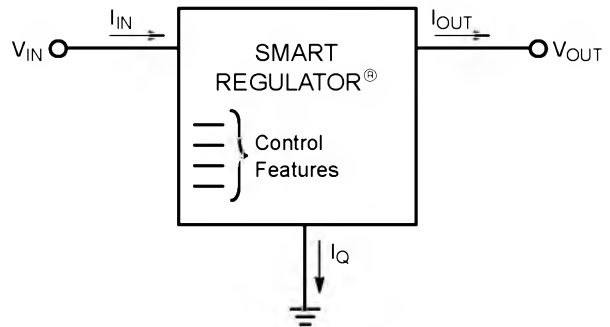

Figure 7. Single Output Regulator With Key Performance Parameters Labeled

HEAT SINKS

A heat sink effectively increases the surface area of the package to improve the flow of heat away from the IC and into the surrounding air.

Each material in the heat flow path between the IC and the outside environment will have a thermal resistance. Like series electrical resistances, these resistances are summed to determine the value of $R_{\theta JA}$.

$$R_{\theta JA} = R_{\theta JC} + R_{\theta CS} + R_{\theta SA} \quad (3)$$

where:

$R_{\theta JC}$ = the junction-to-case thermal resistance,

$R_{\theta CS}$ = the case-to-heatsink thermal resistance, and

$R_{\theta SA}$ = the heatsink-to-ambient thermal resistance.

$R_{\theta JC}$ appears in the package section of the data sheet. Like $R_{\theta JA}$, it too is a function of package type. $R_{\theta CS}$ and $R_{\theta SA}$ are functions of the package type, heatsink and the interface between them. These values appear in heat sink data sheets of heat sink manufacturers.

CS8311

PACKAGE THERMAL DATA

Parameter		SO-8	Unit
R _{θJC}	Typical	45	°C/W
R _{θJA}	Typical	165	°C/W