

# Automotive 4-Mbit (256K x 16) Static RAM

## Features

- Very high speed: 45 ns
- Temperature ranges
  - Automotive-A: -40 °C to +85 °C
  - Automotive-E: -40 °C to +125 °C
- Wide voltage range: 2.20 V to 3.60 V
- Pin compatible with CY62147DV30
- Ultra low standby power
  - Typical standby current: 1 μA
  - Maximum standby current: 7 μA (Automotive-A)
- Ultra low active power
  - Typical active current: 2 mA (Automotive-A) at f = 1 MHz
- Easy memory expansion with  $\overline{CE}$ <sup>[1]</sup> and  $\overline{OE}$  features
- Automatic power down when deselected
- Complementary metal oxide semiconductor (CMOS) for optimum speed and power
- Available in Pb-free 48-ball very fine ball grid array (VFBGA) (single/dual CE option) and 44-pin thin small outline package (TSOP) II packages
- Byte power-down feature

## Functional Description

The CY62147EV30 is a high performance CMOS static RAM (SRAM) organized as 256K words by 16 bits. This device features advanced circuit design to provide ultra low active current. It is ideal for providing More Battery Life™ (MoBL<sup>®</sup>) in portable applications such as cellular telephones. The device

also has an automatic power down feature that significantly reduces power consumption when addresses are not toggling. Placing the device into standby mode reduces power consumption by more than 99 percent when deselected ( $\overline{CE}$  HIGH or both  $\overline{BLE}$  and  $\overline{BHE}$  are HIGH). The input and output pins ( $I/O_0$  through  $I/O_{15}$ ) are placed in a high impedance state when:

- Deselected ( $\overline{CE}$  HIGH)
- Outputs are disabled ( $\overline{OE}$  HIGH)
- Both Byte High Enable and Byte Low Enable are disabled ( $\overline{BHE}$ ,  $\overline{BLE}$  HIGH)
- Write operation is active ( $\overline{CE}$  LOW and  $\overline{WE}$  LOW)

To write to the device, take Chip Enable ( $\overline{CE}$ ) and Write Enable ( $\overline{WE}$ ) inputs LOW. If Byte Low Enable ( $\overline{BLE}$ ) is LOW, then data from I/O pins ( $I/O_0$  through  $I/O_7$ ) is written into the location specified on the address pins ( $A_0$  through  $A_{17}$ ). If Byte High Enable ( $\overline{BHE}$ ) is LOW, then data from I/O pins ( $I/O_8$  through  $I/O_{15}$ ) is written into the location specified on the address pins ( $A_0$  through  $A_{17}$ ).

To read from the device, take Chip Enable ( $\overline{CE}$ ) and Output Enable ( $\overline{OE}$ ) LOW while forcing the Write Enable ( $\overline{WE}$ ) HIGH. If Byte Low Enable ( $\overline{BLE}$ ) is LOW, then data from the memory location specified by the address pins appear on  $I/O_0$  to  $I/O_7$ . If Byte High Enable ( $\overline{BHE}$ ) is LOW, then data from memory appears on  $I/O_8$  to  $I/O_{15}$ . See the Truth Table on page 10 for a complete description of read and write modes.

For best practice recommendations, refer to the Cypress application note AN1064, SRAM System Guidelines.

## Logic Block Diagram

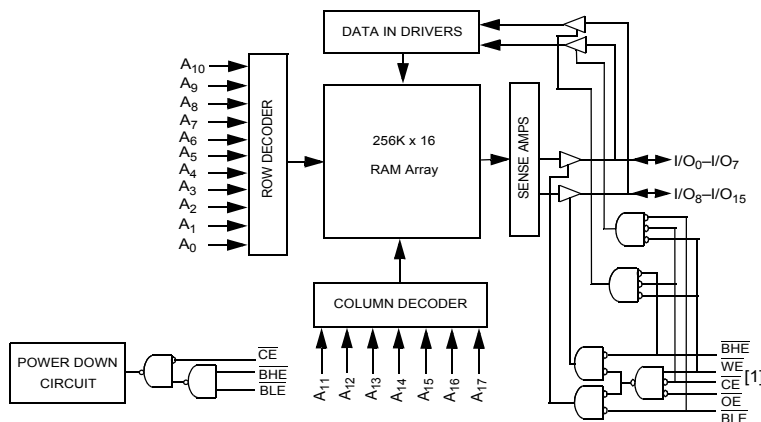

### Note

1. BGA packaged device is offered in single CE and dual CE options. In this data sheet, for a dual CE device,  $\overline{CE}$  refers to the internal logical combination of  $\overline{CE}_1$  and  $\overline{CE}_2$  such that when  $\overline{CE}_1$  is LOW and  $\overline{CE}_2$  is HIGH,  $\overline{CE}$  is LOW. For all other cases  $\overline{CE}$  is HIGH.

## Contents

<b>Product Portfolio</b> .....	<b>3</b>	<b>Ordering Information</b> .....	<b>11</b>
<b>Pin Configuration</b> .....	<b>3</b>	Ordering Code Definitions .....	11
<b>Maximum Ratings</b> .....	<b>4</b>	<b>Package Diagrams</b> .....	<b>12</b>
<b>Operating Range</b> .....	<b>4</b>	<b>Acronyms</b> .....	<b>13</b>
<b>Electrical Characteristics</b> .....	<b>4</b>	<b>Document Conventions</b> .....	<b>13</b>
<b>Capacitance</b> .....	<b>4</b>	Units of Measure .....	13
<b>Thermal Resistance</b> .....	<b>5</b>	<b>Document History Page</b> .....	<b>14</b>
<b>Data Retention Characteristics</b> .....	<b>5</b>	<b>Sales, Solutions, and Legal Information</b> .....	<b>15</b>
<b>Switching Characteristics</b> .....	<b>6</b>	Worldwide Sales and Design Support .....	15
<b>Switching Waveforms</b> .....	<b>7</b>	Products .....	15
<b>Truth Table</b> .....	<b>10</b>	PSoC Solutions .....	15

Product Portfolio

Product	Range	V <sub>CC</sub> Range (V)			Speed (ns)	Power Dissipation					
						Operating I <sub>CC</sub> (mA)				Standby I <sub>SB2</sub> (μA)	
						f = 1 MHz		f = f <sub>max</sub>			
Min	Typ <sup>[2]</sup>	Max	Typ <sup>[2]</sup>	Max	Typ <sup>[2]</sup>	Max	Typ <sup>[2]</sup>	Max			
CY62147EV30LL	Auto-A	2.2	3.0	3.6	45 ns	2	2.5	15	20	1	7
	Auto-E	2.2	3.0	3.6	55 ns	2	3	15	25	1	20

Pin Configuration

Figure 1. 48-Ball VFBGA (Single Chip Enable)<sup>[3, 4]</sup>

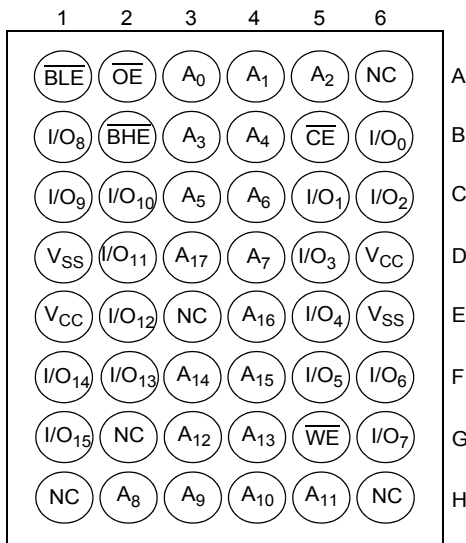

Figure 2. 48-Ball VFBGA (Dual Chip Enable)<sup>[3, 4]</sup>

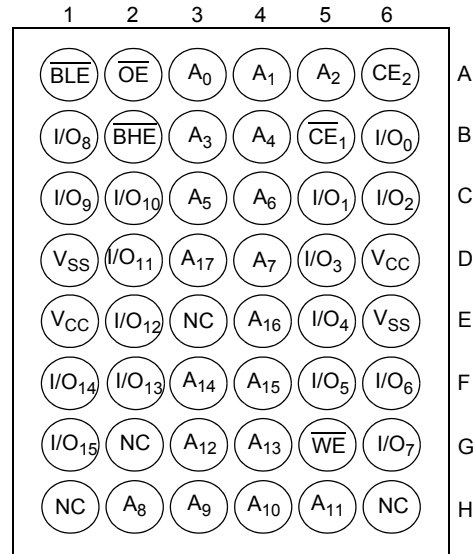
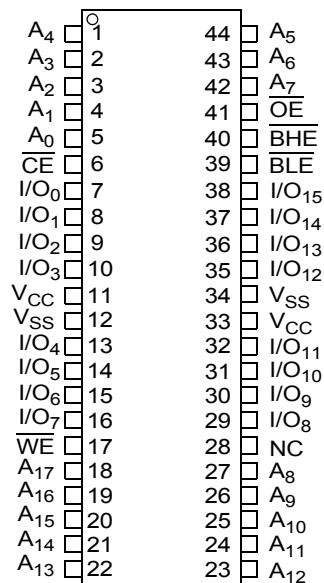

Figure 3. 44-Pin TSOP II<sup>[3]</sup>



Notes

- Typical values are included for reference only and are not guaranteed or tested. Typical values are measured at V<sub>CC</sub> = V<sub>CC(typ)</sub>, T<sub>A</sub> = 25 °C.
- NC pins are not connected on the die.
- Pins H1, G2, and H6 in the BGA package are address expansion pins for 8 Mb, 16 Mb, and 32 Mb, respectively.

## Maximum Ratings

Exceeding the maximum ratings may impair the useful life of the device. User guidelines are not tested.

Storage temperature ..... -65 °C to + 150 °C

Ambient temperature with power applied ..... -55 °C to + 125 °C

Supply voltage to ground potential ..... -0.3 V to + 3.9 V ( $V_{CCmax} + 0.3$  V)

DC voltage applied to outputs in High Z state <sup>[5, 6]</sup> ..... -0.3 V to 3.9 V ( $V_{CCmax} + 0.3$  V)

DC input voltage <sup>[5, 6]</sup> ..... -0.3 V to 3.9 V ( $V_{CCmax} + 0.3$  V)

Output current into outputs (LOW) ..... 20 mA

Static discharge voltage ..... >2001 V (MIL-STD-883, method 3015)

Latch up current..... >200 mA

## Operating Range

Device	Range	Ambient Temperature	V <sub>CC</sub> <sup>[7]</sup>
CY62147EV30LL	Auto-A	-40 °C to +85 °C	2.2 V to 3.6 V
	Auto-E	-40 °C to +125 °C	

## Electrical Characteristics

Over the Operating Range

Parameter	Description	Test Conditions	45 ns (Auto-A)			55 ns (Auto-E)			Unit
			Min	Typ <sup>[8]</sup>	Max	Min	Typ <sup>[8]</sup>	Max	
V <sub>OH</sub>	Output HIGH voltage	I <sub>OH</sub> = -0.1 mA	2.0	-	-	2.0	-	-	V
		I <sub>OH</sub> = -1.0 mA, V <sub>CC</sub> ≥ 2.70 V	2.4	-	-	2.4	-	-	V
V <sub>OL</sub>	Output LOW voltage	I <sub>OL</sub> = 0.1 mA	-	-	0.4	-	-	0.4	V
		I <sub>OL</sub> = 2.1 mA, V <sub>CC</sub> = 2.70 V	-	-	0.4	-	-	0.4	V
V <sub>IH</sub>	Input HIGH voltage	V <sub>CC</sub> = 2.2 V to 2.7 V	1.8	-	V <sub>CC</sub> + 0.3	1.8	-	V <sub>CC</sub> + 0.3	V
		V <sub>CC</sub> = 2.7 V to 3.6 V	2.2	-	V <sub>CC</sub> + 0.3	2.2	-	V <sub>CC</sub> + 0.3	V
V <sub>IL</sub>	Input LOW voltage	V <sub>CC</sub> = 2.2 V to 2.7 V	-0.3	-	0.6	-0.3	-	0.6	V
		V <sub>CC</sub> = 2.7 V to 3.6 V	-0.3	-	0.8	-0.3	-	0.8	V
I <sub>IX</sub>	Input leakage current	GND ≤ V <sub>I</sub> ≤ V <sub>CC</sub>	-1	-	+1	-4	-	+4	μA
I <sub>OZ</sub>	Output leakage current	GND ≤ V <sub>O</sub> ≤ V <sub>CC</sub> , output disabled	-1	-	+1	-4	-	+4	μA
I <sub>CC</sub>	V <sub>CC</sub> operating supply current	f = f <sub>max</sub> = 1/t <sub>RC</sub> V <sub>CC</sub> = V <sub>CC(max)</sub> I <sub>OUT</sub> = 0 mA CMOS levels	-	15	20	-	15	25	mA
		f = 1 MHz	-	2	2.5	-	2	3	
I <sub>SB1</sub>	Automatic CE power-down current—CMOS inputs	$\overline{CE} \geq V_{CC} - 0.2$ V $V_{IN} \geq V_{CC} - 0.2$ V, $V_{IN} \leq 0.2$ V f = f <sub>max</sub> (address and data only), f = 0 (OE, BHE, BLE and WE), V <sub>CC</sub> = 3.60 V	-	1	7	-	1	20	μA
I <sub>SB2</sub> <sup>[9]</sup>	Automatic CE power-down current—CMOS inputs	$\overline{CE} \geq V_{CC} - 0.2$ V $V_{IN} \geq V_{CC} - 0.2$ V or $V_{IN} \leq 0.2$ V, f = 0, V <sub>CC</sub> = 3.60 V	-	1	7	-	1	20	μA

## Capacitance

For all packages.<sup>[10]</sup>

Parameter	Description	Test Conditions	Max	Unit
C <sub>IN</sub>	Input capacitance	T <sub>A</sub> = 25 °C, f = 1 MHz, V <sub>CC</sub> = V <sub>CC(typ)</sub>	10	pF
C <sub>OUT</sub>	Output capacitance		10	pF

### Notes

- V<sub>IL(min)</sub> = -2.0 V for pulse durations less than 20 ns.
- V<sub>IH(max)</sub> = V<sub>CC</sub> + 0.75 V for pulse durations less than 20 ns.
- Full device AC operation assumes a minimum of 100 μs ramp time from 0 to V<sub>CC(min)</sub> and 200 μs wait time after V<sub>CC</sub> stabilization.
- Typical values are included for reference only and are not guaranteed or tested. Typical values are measured at V<sub>CC</sub> = V<sub>CC(typ)</sub>, T<sub>A</sub> = 25 °C.
- Chip enable (CE) and byte enables (BHE and BLE) need to be tied to CMOS levels to meet the I<sub>SB2</sub> / I<sub>CCDR</sub> spec. Other inputs can be left floating.
- Tested initially and after any design or process changes that may affect these parameters.

**Thermal Resistance<sup>[13]</sup>**

Parameter	Description	Test Conditions	VFBGA Package	TSOP II Package	Unit
$\Theta_{JA}$	Thermal resistance (junction to ambient)	Still Air, soldered on a 3 × 4.5 inch, two-layer printed circuit board	75	77	°C / W
$\Theta_{JC}$	Thermal resistance (junction to case)		10	13	°C / W

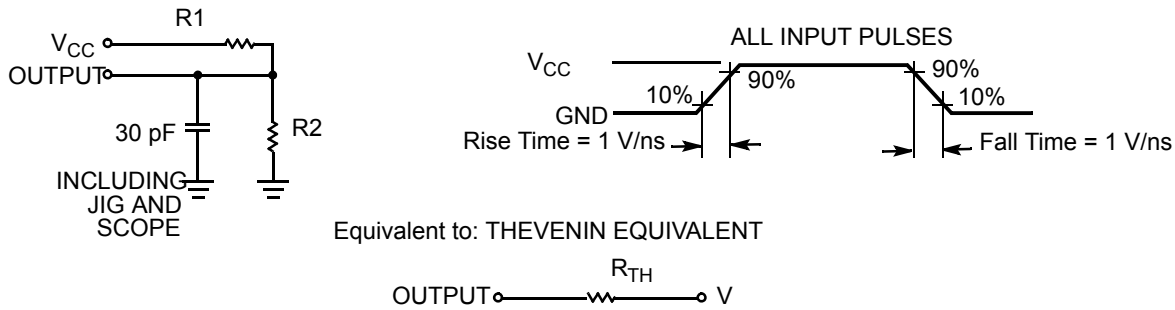
**Figure 4. AC Test Load and Waveforms**

Parameters	2.50 V	3.0 V	Unit
R1	16667	1103	$\Omega$
R2	15385	1554	$\Omega$
$R_{TH}$	8000	645	$\Omega$
$V_{TH}$	1.20	1.75	V

**Data Retention Characteristics**

Over the Operating Range

Parameter	Description	Conditions	Min	Typ <sup>[11]</sup>	Max	Unit
$V_{DR}$	$V_{CC}$ for data retention		1.5	–	–	V
$I_{CCDR}^{[12]}$	Data retention current	$V_{CC} = 1.5\text{ V}$ , $\overline{CE} \geq V_{CC} - 0.2\text{ V}$ , $V_{IN} \geq V_{CC} - 0.2\text{ V}$ or $V_{IN} \leq 0.2\text{ V}$				$\mu\text{A}$
		Auto-A	–	0.8	7	
		Auto-E	–	–	12	
$t_{CDR}^{[13]}$	Chip deselect to data retention time		0	–	–	ns
$t_R^{[14]}$	Operation recovery time					
		CY62147EV30LL-45	45	–	–	ns
		CY62147EV30LL-55	55	–	–	

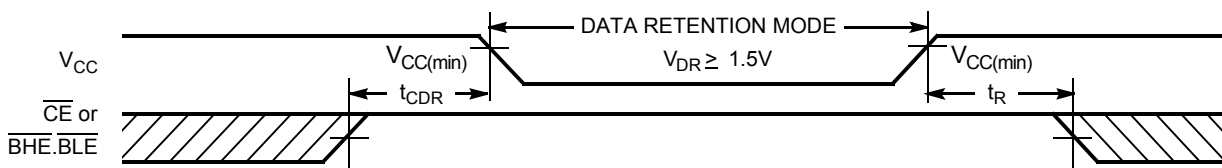
**Figure 5. Data Retention Waveform<sup>[15, 16]</sup>**

**Notes**

- Typical values are included for reference only and are not guaranteed or tested. Typical values are measured at  $V_{CC} = V_{CC(\text{typ})}$ ,  $T_A = 25^\circ\text{C}$ .
- Chip enable (CE) and byte enables (BHE and BLE) need to be tied to CMOS levels to meet the  $I_{SB2} / I_{CCDR}$  spec. Other inputs can be left floating.
- Tested initially and after any design or process changes that may affect these parameters.
- Full device operation requires linear  $V_{CC}$  ramp from  $V_{DR}$  to  $V_{CC(\text{min})} \geq 100\ \mu\text{s}$  or stable at  $V_{CC(\text{min})} \geq 100\ \mu\text{s}$ .
- BGA packaged device is offered in single CE and dual CE options. In this data sheet, for a dual CE device, CE refers to the internal logical combination of  $\overline{CE}_1$  and  $\overline{CE}_2$ , such that when  $\overline{CE}_1$  is LOW and  $\overline{CE}_2$  is HIGH, CE is LOW. For all other cases CE is HIGH.
- BHE.BLE is the AND of both BHE and BLE. Deselect the chip by either disabling the chip enable signals or by disabling both BHE and BLE.

## Switching Characteristics

Over the Operating Range

Parameter <sup>[17, 18]</sup>	Description	45 ns (Auto-A)		55 ns (Auto-E)		Unit
		Min	Max	Min	Max	
<b>Read Cycle</b>						
$t_{RC}$	Read cycle time	45	–	55	–	ns
$t_{AA}$	Address to data valid	–	45	–	55	ns
$t_{OHA}$	Data hold from address change	10	–	10	–	ns
$t_{ACE}$	$\overline{CE}$ LOW to data valid	–	45	–	55	ns
$t_{DOE}$	$\overline{OE}$ LOW to data valid	–	22	–	25	ns
$t_{LZOE}$	$\overline{OE}$ LOW to Low Z <sup>[19]</sup>	5	–	5	–	ns
$t_{HZOE}$	$\overline{OE}$ HIGH to High Z <sup>[19, 20]</sup>	–	18	–	20	ns
$t_{LZCE}$	$\overline{CE}$ LOW to Low Z <sup>[19]</sup>	10	–	10	–	ns
$t_{HZCE}$	$\overline{CE}$ HIGH to High Z <sup>[19, 20]</sup>	–	18	–	20	ns
$t_{PU}$	$\overline{CE}$ LOW to power-up	0	–	0	–	ns
$t_{PD}$	$\overline{CE}$ HIGH to power-down	–	45	–	55	ns
$t_{DBE}$	$\overline{BLE}/\overline{BHE}$ LOW to data valid	–	45	–	55	ns
$t_{LZBE}$	$\overline{BLE}/\overline{BHE}$ LOW to Low Z <sup>[19]</sup>	10	–	10	–	ns
$t_{HZBE}$	$\overline{BLE}/\overline{BHE}$ HIGH to HIGH Z <sup>[19, 20]</sup>	–	18	–	20	ns
<b>Write Cycle<sup>[21]</sup></b>						
$t_{WC}$	Write cycle time	45	–	55	–	ns
$t_{SCE}$	$\overline{CE}$ LOW to write end	35	–	40	–	ns
$t_{AW}$	Address setup to write end	35	–	40	–	ns
$t_{HA}$	Address hold from write end	0	–	0	–	ns
$t_{SA}$	Address setup to write start	0	–	0	–	ns
$t_{PWE}$	$\overline{WE}$ pulse width	35	–	40	–	ns
$t_{BW}$	$\overline{BLE}/\overline{BHE}$ LOW to write end	35	–	40	–	ns
$t_{SD}$	Data setup to write end	25	–	25	–	ns
$t_{HD}$	Data hold from write end	0	–	0	–	ns
$t_{HZWE}$	$\overline{WE}$ LOW to High Z <sup>[19, 20]</sup>	–	18	–	20	ns
$t_{LZWE}$	$\overline{WE}$ HIGH to Low Z <sup>[19]</sup>	10	–	10	–	ns

### Notes

17. Test conditions for all parameters other than tri-state parameters assume signal transition time of 3 ns (1V/ns) or less, timing reference levels of  $V_{CC(typ)}/2$ , input pulse levels of 0 to  $V_{CC(typ)}$ , and output loading of the specified  $I_{OL}/I_{OH}$  as shown in the [AC Test Load and Waveforms on page 5](#).

18. AC timing parameters are subject to byte enable signals (BHE or BLE) not switching when chip is disabled. See application note [AN13842](#) for further clarification.

19. At any temperature and voltage condition,  $t_{HZCE}$  is less than  $t_{LZCE}$ ,  $t_{HZBE}$  is less than  $t_{LZBE}$ ,  $t_{HZOE}$  is less than  $t_{LZOE}$ , and  $t_{HZWE}$  is less than  $t_{LZWE}$  for any device.

20.  $t_{HZOE}$ ,  $t_{HZCE}$ ,  $t_{HZBE}$ , and  $t_{HZWE}$  transitions are measured when the outputs enter a high impedance state.

21. The internal write time of the memory is defined by the overlap of  $\overline{WE}$ ,  $\overline{CE} = V_{IL}$ ,  $\overline{BHE}$ ,  $\overline{BLE}$ , or both =  $V_{IL}$ . All signals must be active to initiate a write and any of these signals can terminate a write by going inactive. The data input setup and hold timing must be referenced to the edge of the signal that terminates the write.

## Switching Waveforms

Figure 6. Read Cycle No. 1 Address Transition Controlled<sup>[22, 23]</sup>

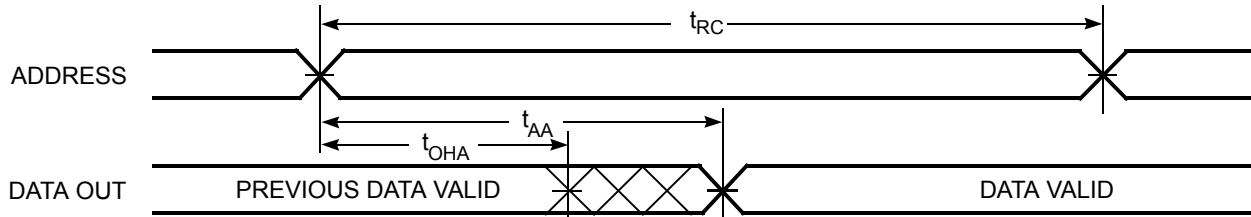
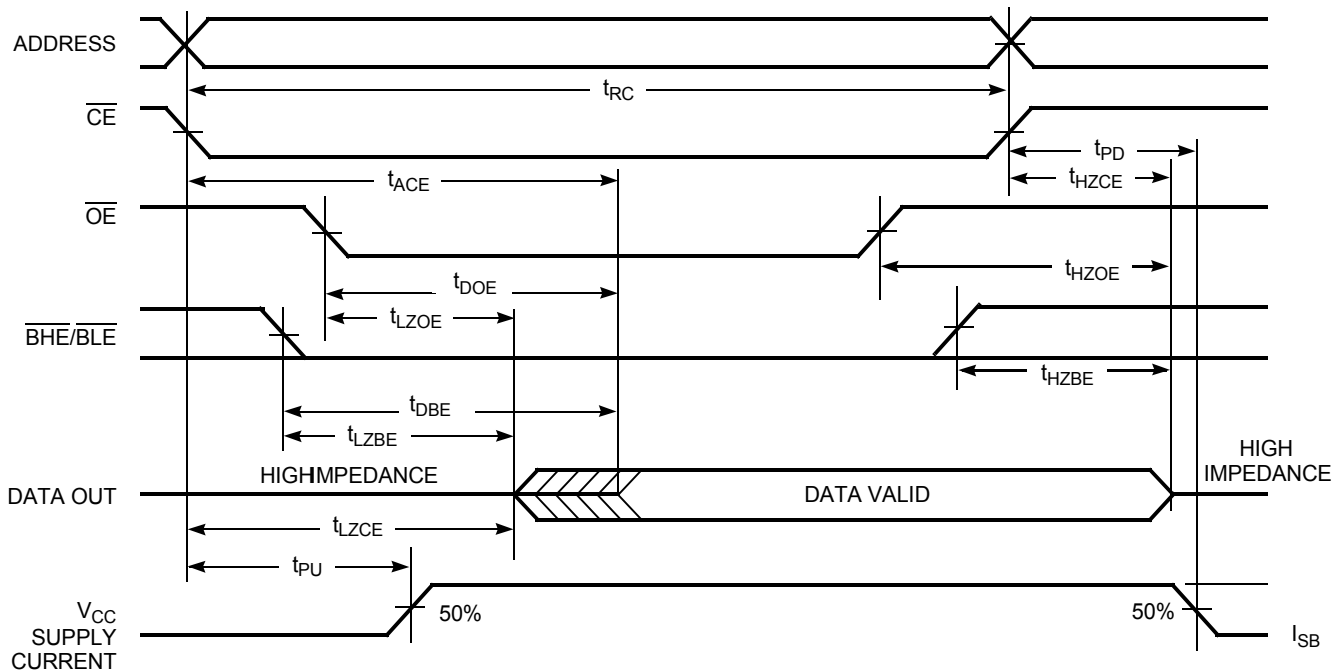

Figure 7. Read Cycle No. 2:  $\overline{OE}$  Controlled<sup>[23, 24, 25]</sup>



### Notes

22. The device is continuously selected.  $\overline{OE}$ ,  $\overline{CE}$  =  $V_{IL}$ ,  $\overline{BHE}$ ,  $\overline{BLE}$ , or both =  $V_{IL}$ .

23.  $\overline{WE}$  is HIGH for read cycle.

24. BGA packaged device is offered in single CE and dual CE options. In this data sheet, for a dual CE device,  $\overline{CE}$  refers to the internal logical combination of  $\overline{CE}_1$  and  $\overline{CE}_2$  such that when  $\overline{CE}_1$  is LOW and  $\overline{CE}_2$  is HIGH,  $\overline{CE}$  is LOW. For all other cases  $\overline{CE}$  is HIGH.

25. Address valid before or similar to  $\overline{CE}$  and  $\overline{BHE}$ ,  $\overline{BLE}$  transition LOW.

Switching Waveforms (continued)

Figure 8. Write Cycle No. 1:  $\overline{\text{WE}}$  Controlled [26, 27, 28, 29]

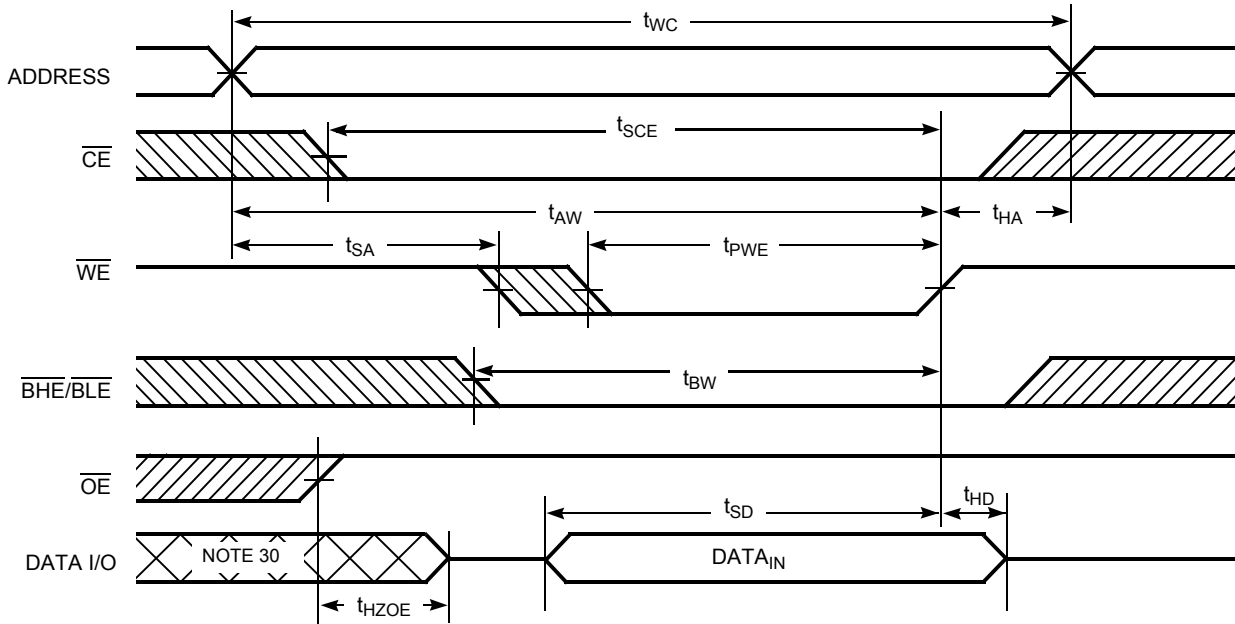
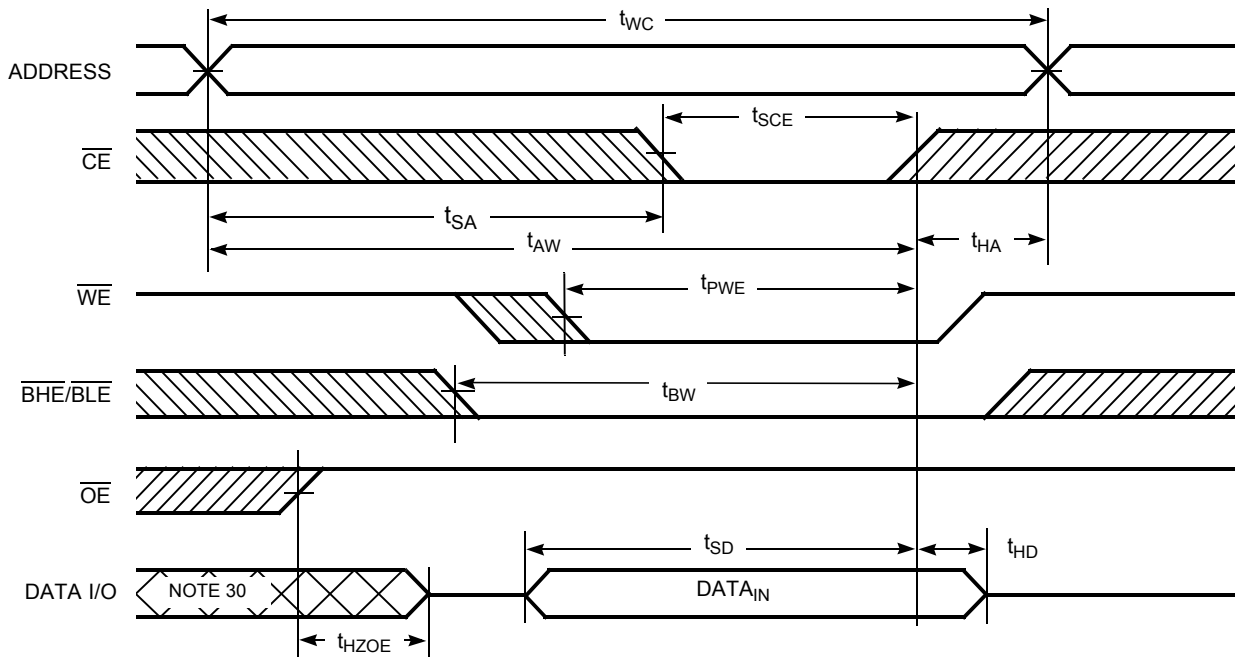

Figure 9. Write Cycle No. 2:  $\overline{\text{CE}}$  Controlled [26, 27, 28, 29]



Notes

- 26. BGA packaged device is offered in single CE and dual CE options. In this data sheet, for a dual CE device,  $\overline{\text{CE}}$  refers to the internal logical combination of  $\overline{\text{CE}}_1$  and  $\text{CE}_2$  such that when  $\text{CE}_1$  is LOW and  $\text{CE}_2$  is HIGH,  $\overline{\text{CE}}$  is LOW. For all other cases  $\overline{\text{CE}}$  is HIGH.
- 27. The internal write time of the memory is defined by the overlap of  $\overline{\text{WE}}$ ,  $\overline{\text{CE}} = V_{\text{IL}}$ ,  $\overline{\text{BHE}}$ ,  $\overline{\text{BLE}}$ , or both =  $V_{\text{IL}}$ . All signals must be active to initiate a write and any of these signals can terminate a write by going inactive. The data input setup and hold timing must be referenced to the edge of the signal that terminates the write.
- 28. Data I/O is high impedance if  $\text{OE} = V_{\text{IH}}$ .
- 29. If  $\overline{\text{CE}}$  goes HIGH simultaneously with  $\overline{\text{WE}} = V_{\text{IH}}$ , the output remains in a high impedance state.
- 30. During this period, the I/Os are in output state. Do not apply input signals.



Switching Waveforms (continued)

Figure 10. Write Cycle No. 3:  $\overline{WE}$  Controlled,  $\overline{OE}$  LOW<sup>[31, 32]</sup>

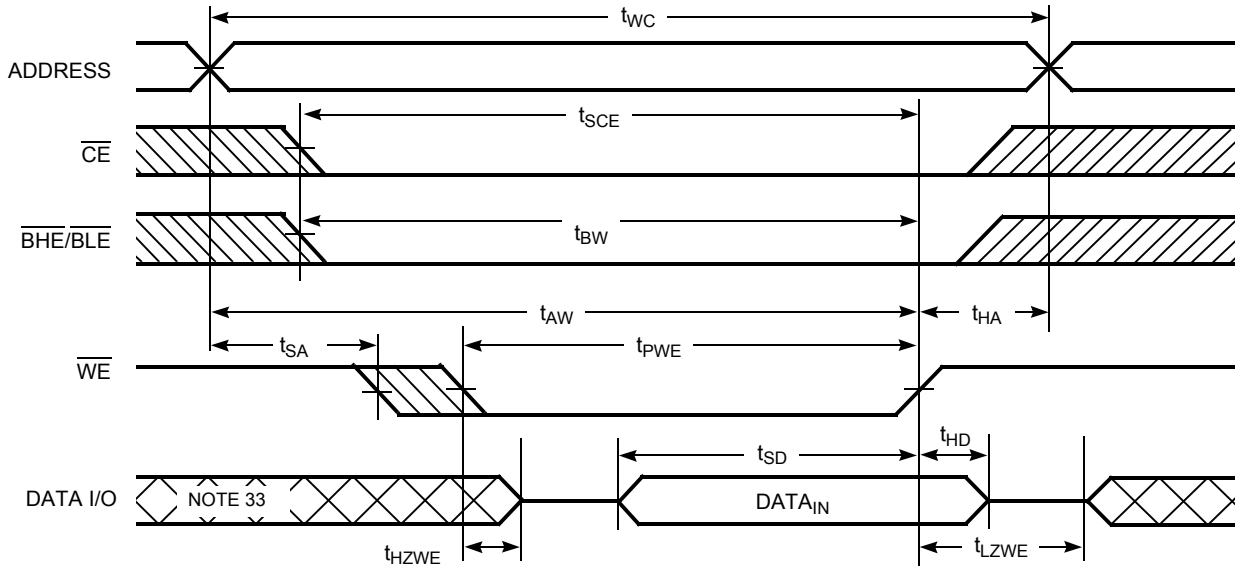
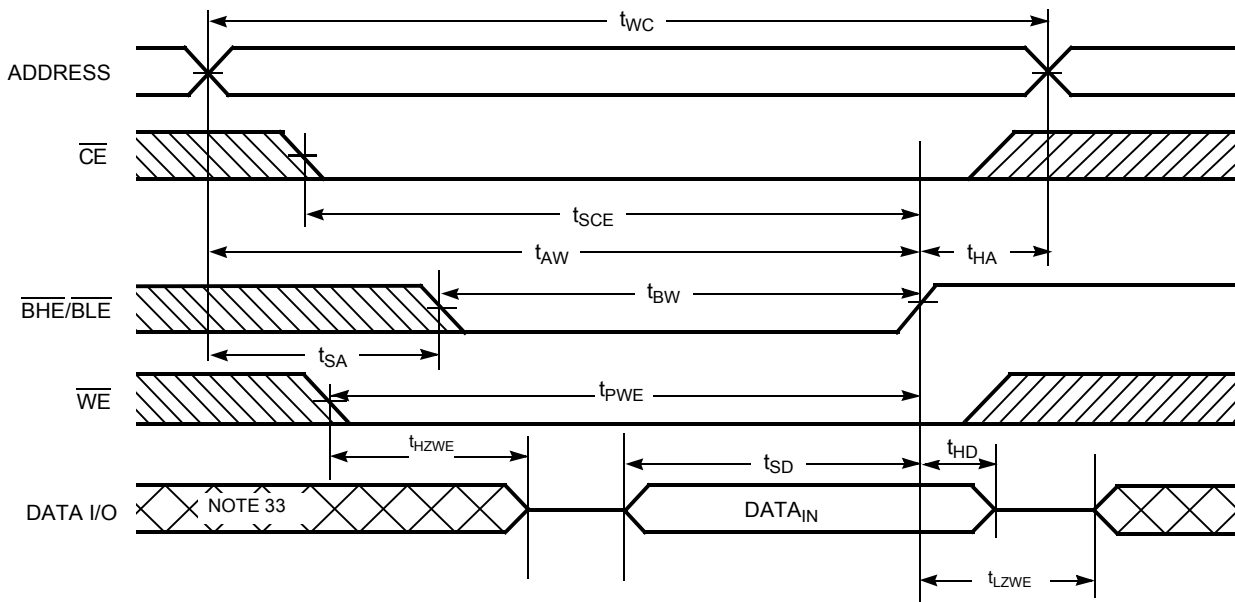

Figure 11. Write Cycle No. 4:  $\overline{BHE}/\overline{BLE}$  Controlled,  $\overline{OE}$  LOW<sup>[31, 32]</sup>



Notes

- 31. BGA packaged device is offered in single CE and dual CE options. In this data sheet, for a dual CE device,  $\overline{CE}$  refers to the internal logical combination of  $\overline{CE}_1$  and  $\overline{CE}_2$  such that when  $\overline{CE}_1$  is LOW and  $\overline{CE}_2$  is HIGH,  $\overline{CE}$  is LOW. For all other cases  $\overline{CE}$  is HIGH.
- 32. If  $\overline{CE}$  goes HIGH simultaneously with  $WE = V_{IH}$ , the output remains in a high impedance state.
- 33. During this period, the I/Os are in output state. Do not apply input signals.

**Truth Table**

$\overline{CE}$ <sup>[34, 35]</sup>	$\overline{WE}$	$\overline{OE}$	$\overline{BHE}$	$\overline{BLE}$	I/Os	Mode	Power
H	X	X	X	X	High Z	Deselect/power-down	Standby ( $I_{SB}$ )
L	X	X	H	H	High Z	Deselect/power-down	Standby ( $I_{SB}$ )
L	H	L	L	L	Data out (I/O <sub>0</sub> –I/O <sub>15</sub> )	Read	Active ( $I_{CC}$ )
L	H	L	H	L	Data out (I/O <sub>0</sub> –I/O <sub>7</sub> ); I/O <sub>8</sub> –I/O <sub>15</sub> in High Z	Read	Active ( $I_{CC}$ )
L	H	L	L	H	Data out (I/O <sub>8</sub> –I/O <sub>15</sub> ); I/O <sub>0</sub> –I/O <sub>7</sub> in High Z	Read	Active ( $I_{CC}$ )
L	H	H	L	L	High Z	Output disabled	Active ( $I_{CC}$ )
L	H	H	H	L	High Z	Output disabled	Active ( $I_{CC}$ )
L	H	H	L	H	High Z	Output disabled	Active ( $I_{CC}$ )
L	L	X	L	L	Data in (I/O <sub>0</sub> –I/O <sub>15</sub> )	Write	Active ( $I_{CC}$ )
L	L	X	H	L	Data in (I/O <sub>0</sub> –I/O <sub>7</sub> ); I/O <sub>8</sub> –I/O <sub>15</sub> in High Z	Write	Active ( $I_{CC}$ )
L	L	X	L	H	Data in (I/O <sub>8</sub> –I/O <sub>15</sub> ); I/O <sub>0</sub> –I/O <sub>7</sub> in High Z	Write	Active ( $I_{CC}$ )

**Notes**

34. BGA packaged device is offered in single CE and dual CE options. In this data sheet, for a dual CE device,  $\overline{CE}$  refers to the internal logical combination of  $\overline{CE}_1$  and  $\overline{CE}_2$  such that when  $\overline{CE}_1$  is LOW and  $\overline{CE}_2$  is HIGH,  $\overline{CE}$  is LOW. For all other cases  $\overline{CE}$  is HIGH.

35. For the DualChip Enable device,  $\overline{CE}$  refers to the internal logical combination of  $\overline{CE}_1$  and  $\overline{CE}_2$  such that when  $\overline{CE}_1$  is LOW and  $\overline{CE}_2$  is HIGH,  $\overline{CE}$  is LOW. For all other cases  $\overline{CE}$  is HIGH. Intermediate voltage levels is not permitted on any of the Chip Enable pins (CE for the Single Chip Enable device;  $\overline{CE}_1$  and  $\overline{CE}_2$  for the Dual Chip Enable device).

### Ordering Information

Speed (ns)	Ordering Code	Package Diagram	Package Type	Operating Range
45	CY62147EV30LL-45BVXA	51-85150	48-Ball Very Fine Pitch Ball Grid Array (Pb-free) <sup>[36]</sup>	Automotive-A
	CY62147EV30LL-45B2XA	51-85150	48-Ball Very Fine Pitch Ball Grid Array (Pb-free) <sup>[37]</sup>	
	CY62147EV30LL-45ZSXA	51-85087	44-Pin Thin Small Outline Package II (Pb-free)	
55	CY62147EV30LL-55ZSXE	51-85087	44-Pin Thin Small Outline Package II (Pb-free)	Automotive-E

Contact your local Cypress sales representative for availability of these parts.

### Ordering Code Definitions

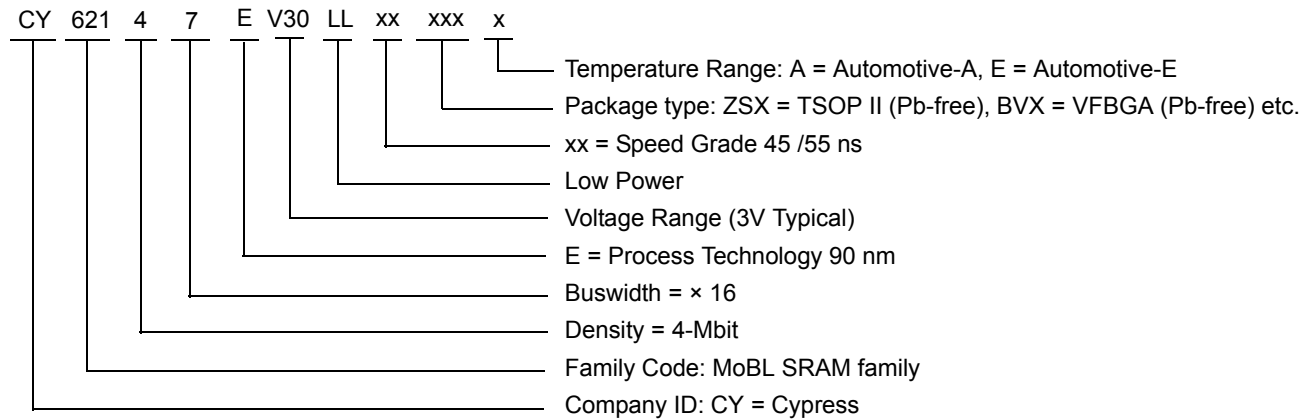

**Notes**

- 36. This BGA package is offered with single chip enable.
- 37. This BGA package is offered with dual chip enable.

Package Diagrams

Figure 12. 48-Ball VFBGA (6 x 8 x 1 mm), 51-85150

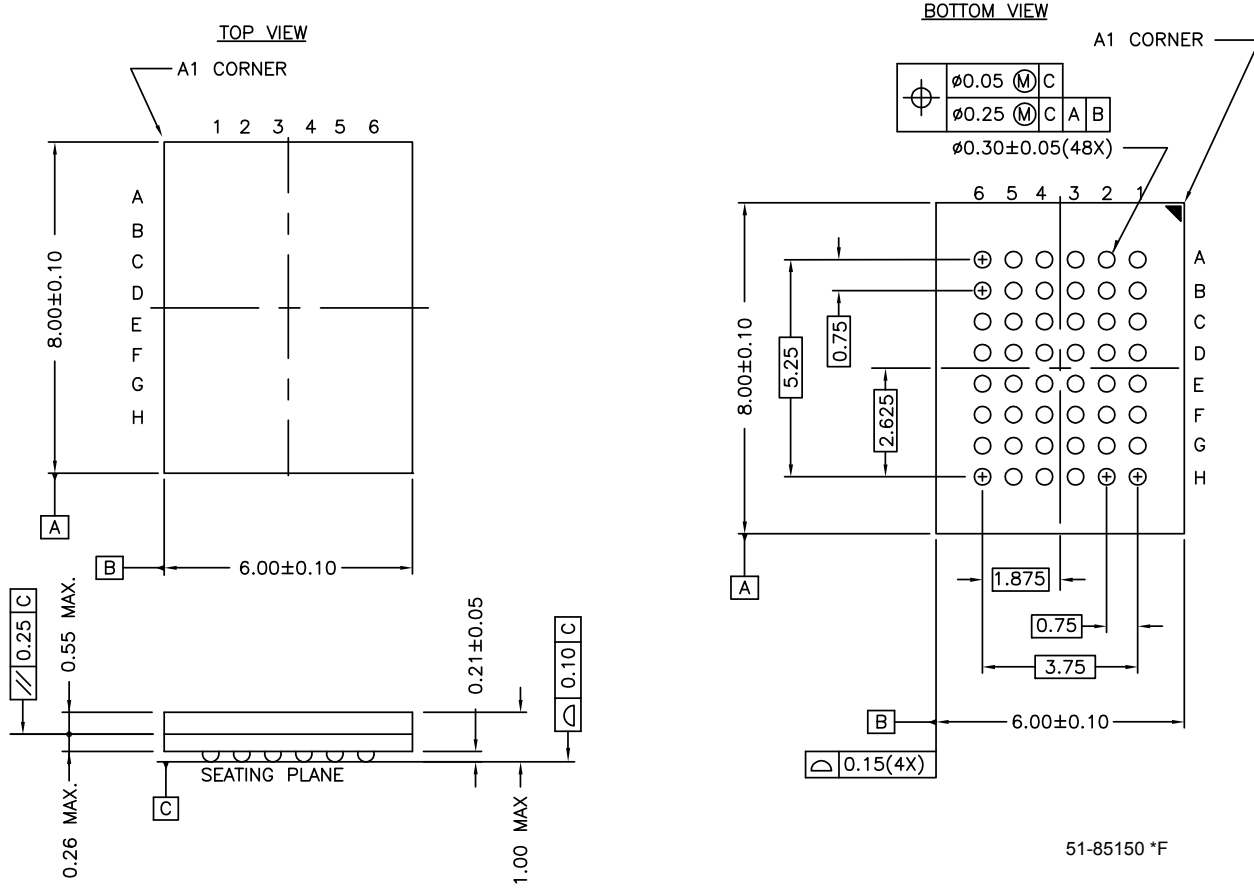

Package Diagrams (continued)

Figure 13. 44-Pin TSOP II, 51-85087

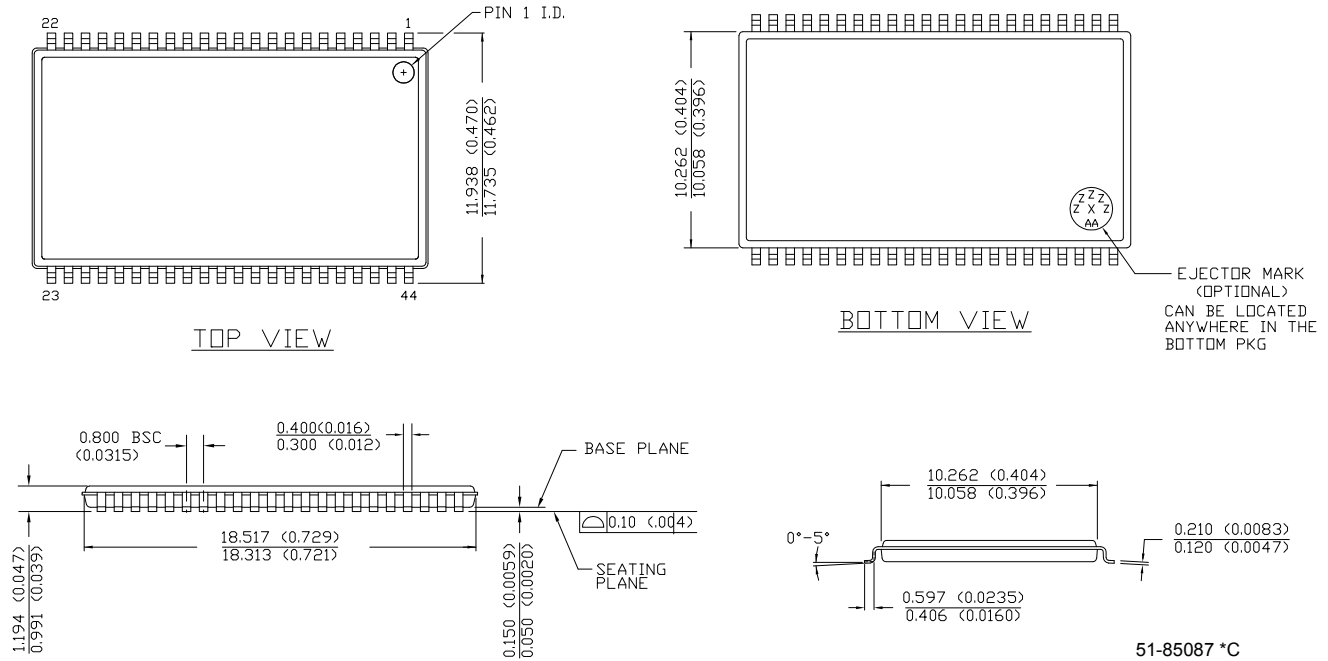

Acronyms

Acronym	Description
CMOS	complementary metal oxide semiconductor
I/O	input/output
SRAM	static random access memory
VFBGA	very fine ball grid array
TSOP	thin small outline package

Document Conventions

Units of Measure

Symbol	Unit of Measure
°C	degrees Celsius
μA	microamperes
mA	milliamperes
MHz	megahertz
ns	nanoseconds
pF	picofarads
V	volts
Ω	ohms
W	watts

## Document History Page

Document Title: CY62147EV30 MoBL <sup>®</sup> Automotive 4-Mbit (256K x 16) Static RAM				
Document Number: 001-66256				
Rev.	ECN No.	Orig. of Change	Submission Date	Description of Change
**	3123973	RAME	01/31/2011	Created new datasheet for Automotive parts from document number 38-05440 Rev. *I

## Sales, Solutions, and Legal Information

### Worldwide Sales and Design Support

Cypress maintains a worldwide network of offices, solution centers, manufacturer's representatives, and distributors. To find the office closest to you, visit us at [Cypress Locations](#).

### Products

Automotive	<a href="http://cypress.com/go/automotive">cypress.com/go/automotive</a>
Clocks & Buffers	<a href="http://cypress.com/go/clocks">cypress.com/go/clocks</a>
Interface	<a href="http://cypress.com/go/interface">cypress.com/go/interface</a>
Lighting & Power Control	<a href="http://cypress.com/go/powerpsoc">cypress.com/go/powerpsoc</a> <a href="http://cypress.com/go/plc">cypress.com/go/plc</a>
Memory	<a href="http://cypress.com/go/memory">cypress.com/go/memory</a>
Optical & Image Sensing	<a href="http://cypress.com/go/image">cypress.com/go/image</a>
PSoC	<a href="http://cypress.com/go/psoc">cypress.com/go/psoc</a>
Touch Sensing	<a href="http://cypress.com/go/touch">cypress.com/go/touch</a>
USB Controllers	<a href="http://cypress.com/go/USB">cypress.com/go/USB</a>
Wireless/RF	<a href="http://cypress.com/go/wireless">cypress.com/go/wireless</a>

### PSoC Solutions

[psoc.cypress.com/solutions](http://psoc.cypress.com/solutions)  
PSoC 1 | PSoC 3 | PSoC 5

---

© Cypress Semiconductor Corporation, 2011. The information contained herein is subject to change without notice. Cypress Semiconductor Corporation assumes no responsibility for the use of any circuitry other than circuitry embodied in a Cypress product. Nor does it convey or imply any license under patent or other rights. Cypress products are not warranted nor intended to be used for medical, life support, life saving, critical control or safety applications, unless pursuant to an express written agreement with Cypress. Furthermore, Cypress does not authorize its products for use as critical components in life-support systems where a malfunction or failure may reasonably be expected to result in significant injury to the user. The inclusion of Cypress products in life-support systems application implies that the manufacturer assumes all risk of such use and in doing so indemnifies Cypress against all charges.

Any Source Code (software and/or firmware) is owned by Cypress Semiconductor Corporation (Cypress) and is protected by and subject to worldwide patent protection (United States and foreign), United States copyright laws and international treaty provisions. Cypress hereby grants to licensee a personal, non-exclusive, non-transferable license to copy, use, modify, create derivative works of, and compile the Cypress Source Code and derivative works for the sole purpose of creating custom software and or firmware in support of licensee product to be used only in conjunction with a Cypress integrated circuit as specified in the applicable agreement. Any reproduction, modification, translation, compilation, or representation of this Source Code except as specified above is prohibited without the express written permission of Cypress.

Disclaimer: CYPRESS MAKES NO WARRANTY OF ANY KIND, EXPRESS OR IMPLIED, WITH REGARD TO THIS MATERIAL, INCLUDING, BUT NOT LIMITED TO, THE IMPLIED WARRANTIES OF MERCHANTABILITY AND FITNESS FOR A PARTICULAR PURPOSE. Cypress reserves the right to make changes without further notice to the materials described herein. Cypress does not assume any liability arising out of the application or use of any product or circuit described herein. Cypress does not authorize its products for use as critical components in life-support systems where a malfunction or failure may reasonably be expected to result in significant injury to the user. The inclusion of Cypress' product in a life-support systems application implies that the manufacturer assumes all risk of such use and in doing so indemnifies Cypress against all charges.

Use may be limited by and subject to the applicable Cypress software license agreement.