

HD61830B

LCTC (LCD Timing Controller)

T-52-13-07

Description

The HD61830B is a dot matrix liquid crystal graphic display controller LSI that stores the display data sent from an 8-bit microcontroller in the external RAM to generate dot matrix liquid crystal driving signals.

It has a graphic mode in which 1-bit data in the external RAM corresponds to the on/off state of 1 dot on liquid crystal display and a character mode in which characters are displayed by storing character codes in the external RAM and developing them into the dot patterns with the internal character generator ROM. Both modes can be provided for various applications.

The HD61830B is produced by the CMOS process. Thus, combined with a CMOS microcontroller it can complete a liquid crystal display device with lower power dissipation.

Pin Arrangement

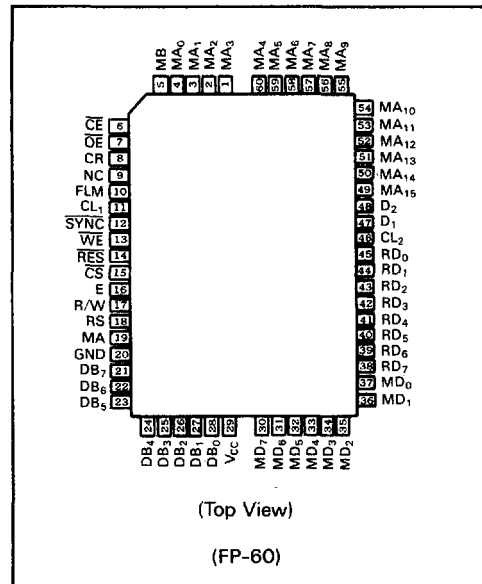

Features

- Dot matrix liquid crystal graphic display controller
- Display control capacity
 - Graphic mode: 512k dots (2^{16} bytes)
 - Character mode: 4096 characters (2^{12} characters)
- Internal character generator ROM: 7360 bits
 - 160 types of 5×7 dot characters
 - 32 types of 5×11 dot characters
 - Total 192 characters
 - Can be extended to 256 characters (4k bytes max.) by external ROM
- Interfaces to 8-bit MPU
- Display duty cycle (Can be selected by a program)
 - Static to 1/128 duty cycle
- Various instruction functions
 - Scroll, Cursor on/off/blink, Character blink, Bit manipulation
- Display method: Selectable A or B types
- Operating frequency: 2.4 MHz
- Low power dissipation
- Power supply: Single +5 V \pm 10%
- CMOS process
- Package: 60-pin plastic QFP (FP-60)

5

HITACHI

HD61830B

T-52-13-07

Block Diagram

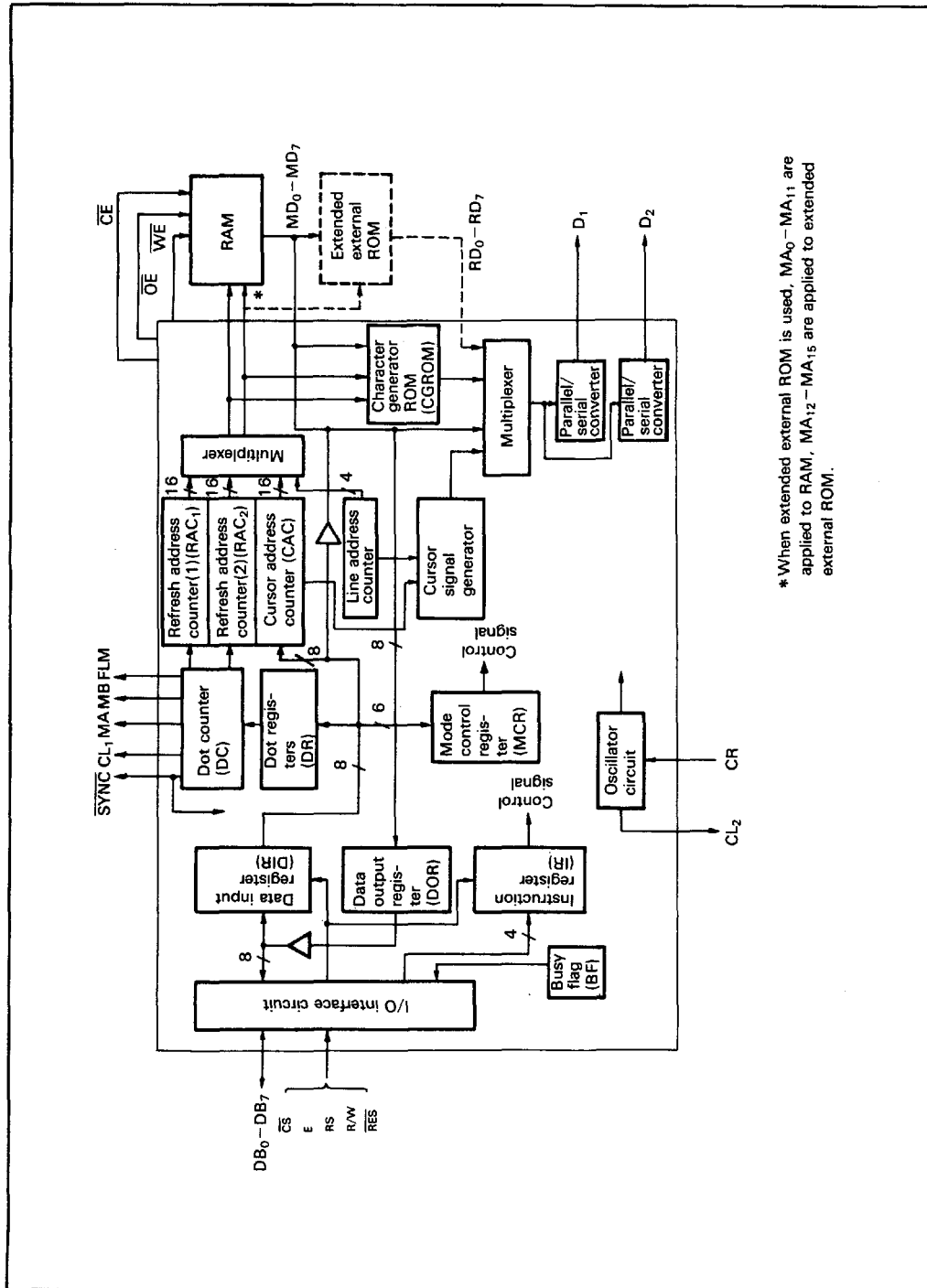

* When extended external ROM is used, MA₀-MA₁₁ are applied to RAM, MA₁₂-MA₁₅ are applied to extended external ROM.

HITACHI

Block Functions**Registers**

The HD61830B has the five types of registers: instruction register (IR), data input register (DIR), data output register (DOR), dot registers (DR), and mode control register (MCR).

The IR is a 4-bit register that stores the instruction codes for specifying MCR, DR, a start address register, a cursor address register, and so on. The lower order 4 bits DB0 to DB3 of data buses are written in it.

The DIR is an 8-bit register used to temporarily store the data written into the external RAM, DR, MCR, and so on.

The DOR is an 8-bit register used to temporarily store the data read from the external RAM. Cursor address information is written into the cursor address counter (CAC) through the DIR. When the memory read instruction is set in the IR (latched at the falling edge of E signal), the data of external RAM is read to DOR by an internal operation. The data is transferred to the MPU by reading the DOR with the next instruction (the contents of DOR are output to the data bus when E is at the High level).

The DR are registers used to store dot information such as character pitches and the number of vertical dots and so on. The information sent from the MPU is written into the DR via the DIR.

The MCR is a 6-bit register used to store the data which specifies states of display such as display on/off and cursor on/off/blink. The information sent from the MPU is written in it via the DIR.

Busy Flag (BF)

The busy flag = 1 indicates the HD61830B is performing an internal operation. Instructions cannot be accepted. As shown in Control Instruction, read busy flag, the busy flag is output on DB7 under the conditions of RS = 1, R/W = 1, and E = 1. Make sure the busy flag is 0 before writing the next instruction.

Dot Counters (DC)

The dot counters are counters that generate liquid crystal display timing according to the contents of DR.

Refresh Address Counters (RAC1/RAC2)

The refresh address counters RAC1 and RAC2 control the addresses of external RAM, character generator ROM (CGROM), and extended external ROM. The RAC1 is used for upper half of the screen and the RAC2 for the lower half. In the graphic mode, 16-bit data is output and used as the address signal of external RAM. In the character mode, the high order 4 bits (MA12-MA15) are ignored. The 4 bits of line address counter are output instead and used as the address of extended ROM.

Character Generator ROM

The character generator ROM has 7360 bits in total and stores 192 types of character data. A character code (8 bits) from the external RAM and a line code (4 bits) from the line address counter are applied to its address signals, and it outputs 5-bit dot data.

The character font is 5×7 (160 characters) or 5×11 (32 characters). The use of extended ROM allows 8×16 (256 characters max.) to be used.

Cursor Address Counter

The cursor address counter is a 16-bit counter that can be preset by instruction. It holds an address when the data of external RAM is read or written (when display dot data or a character code is read or written). The value of the cursor address counter is automatically increased by 1 after the display data is read or written and after the set/clear bit instruction is executed.

Cursor Signal Generator

The cursor can be displayed by instruction in character mode. The cursor is automatically generated on the display specified by the cursor address and cursor position.

Parallel/Serial Conversion

The parallel data sent from the external RAM, character generator ROM, or extended ROM is converted into serial data by two parallel/serial conversion circuits and transferred to the liquid crystal driver circuits for upper screen and lower screen simultaneously.

HD61830B

T-52-13-07

Terminal Functions

Name	Function
DB0-DB7	Data bus: Three-state I/O common terminal Data is transferred to MPU through DB0 to DB7.
\overline{CS}	Chip select: Selected state with $\overline{CS} = 0$
R/W	Read/Write: R/W = 1: MPU ← HD61830B R/W = 0: MPU → HD61830B
RS	Register select: RS = 1: Instruction register RS = 0: Data register
E	Enable: Data is written at the fall of E Data can be read while E is 1
CR	External clock input
RES	Reset: RES = 0 results in display off, slave mode and Hp = 6
MA0-MA15	External RAM address output In character mode, the lane code for external CG is output through MA12 to MA15 (O: Character 1st line, F: Character 16th line)
MDO-MD7	Display data bus: Three-state I/O common terminal
RDO-RD7	ROM data input: Dot data from external character generator is input
WE	Write enable: Write signal for external RAM
CL2	Display data shift clock for LCD drivers
CL1	Display data latch signal for LCD drivers
FLM	Frame signal for display synchronization
MA	Signal for converting liquid crystal driving signal into AC, A type
MB	Signal for converting liquid crystal driving signal into AC, B type
D1, D2	Display data serial output D1: For upper half of screen D2: For lower half of screen
SYNC	Synchronous signal for parallel operation Three-state I/O common terminal (with pull-up MOS) Master: Synchronous signal is output Slave: Synchronous signal is input
CE	Chip enable $\overline{CE} = 0$: Chip enables make external RAM in active
OE	Output enable $\overline{OE} = 1$: Output enable informs external RAM that HD61830B requires data bus
NC	Unused terminal. Don't connect any wires to this terminal

HITACHI

HD61830B

T-52-13-07

Absolute Maximum Ratings

Item	Symbol	Value	Unit	Note
Supply voltage	V_{CC}	- 0.3 to + 0.7	V	1, 2
Terminal voltage	V_T	- 0.3 to $V_{CC} + 0.3$	V	1, 2
Operating temperature	T_{opr}	- 20 to + 75	°C	
Storage temperature	T_{stg}	- 55 to + 125	°C	

- Notes: 1. All voltage is referred to GND = 0 V.
 2. If LSIs are used beyond absolute maximum ratings, they may be permanently destroyed. We strongly recommend that you use the LSIs within electrical characteristic limits for normal operation, because use beyond these conditions will cause malfunction and poor reliability.

Electrical Characteristics

Item	Symbol	Min	Typ	Max	Unit	Test Condition	Note
Input high voltage (TTL)	V_{IH}	2.2	—	V_{CC}	V		1
Input low voltage (TTL)	V_{IL}	0	—	0.8	V		2
Input high voltage	V_{IHR}	3.0	—	V_{CC}	V		3
Input high voltage (CMOS)	V_{IHC}	0.7 V_{CC}	—	V_{CC}	V		4
Input low voltage (CMOS)	V_{ILC}	0	—	0.3 V_{CC}	V		4
Output high voltage (TTL)	V_{OH}	2.4	—	V_{CC}	V	- $I_{OH} = 0.6$ mA	5
Output low voltage (TTL)	V_{OL}	0	—	0.4	V	$I_{OL} = 1.6$ mA	5
Output high voltage (CMOS)	V_{OHC}	$V_{CC} - 0.4$	—	V_{CC}	V	- $I_{OH} = 0.6$ mA	6
Output low voltage (CMOS)	V_{OLC}	0	—	0.4	V	$I_{OL} = 0.6$ mA	6
Input leakage current	I_{IN}	- 5	—	5	μ A	$V_{IN} = 0 - V_{CC}$	7
Three-state leakage current	I_{TSL}	- 10	—	10	μ A	$V_{OUT} = 0 - V_{CC}$	8
Pull-up current	I_{PL}	2	10	20	μ A	$V_{in} = GND$	9
Power dissipation	P_W	—	—	50	mW	External clock $f_{cp} = 2.4$ MHz	10

- Notes: 1. Applied to input terminals and I/O common terminals, except terminals \overline{SYNC} , CR, and RES.
 2. Applied to input terminals and I/O common terminals, except terminals \overline{SYNC} and CR.
 3. Applied to terminal RES.
 4. Applied to terminals \overline{SYNC} and CR.
 5. Applied to terminals DB0-DB7, WE, MA0-MA15, \overline{OE} , \overline{CE} , and MD0-MD7.
 6. Applied to terminals \overline{SYNC} , FLM, CL1, CL2, D1, D2, MA, and MB.
 7. Applied to input terminals.
 8. Applied to I/O common terminals. However, the current which flows into the output drive MOS is excluded.
 9. Applied to \overline{SYNC} , DB0-DB7, and RD0-RD7.
 10. The current which flows into the input and output circuits is excluded. When the input of CMOS is in the intermediate level, current flows through the input circuit, resulting in the increase of power supply current. To avoid this, input must be fixed at high or low.

HITACHI

T-52-13-07

Input Terminal

Applicable terminal: \overline{CS} , E, RS, R/W, \overline{RES} , CR
 (Without pull-up MOS)

Applicable terminal: RD0-RD7 (With pull-up MOS)

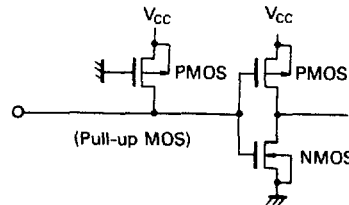
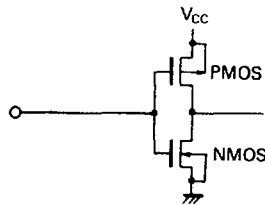

Output Terminal

Applicable terminal: CL1, CL2, MA, MB, FLM,
 D1, D2, \overline{WE} , \overline{OE} , \overline{CE} , MA0-MA15

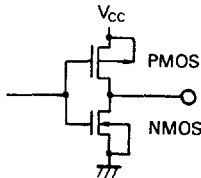

I/O Common Terminal

Applicable terminal: DB0-DB7, \overline{SYNC} , MD0-
 MD7 (MD0-MD7 have no pull-up MOS)

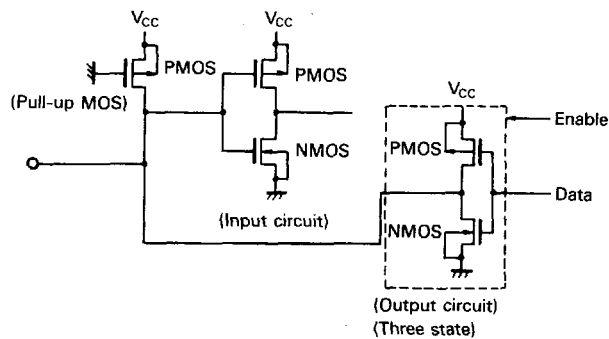

HITACHI

Clock Operation

T-52-13-07

Item	Symbol	Min	Typ	Max	Unit	Note
External clock operating frequency	f_{cp}	100	—	2400	kHz	1
External clock duty	Duty	47.5	50	52.5	%	1
External clock rise time	t_{rcp}	—	—	25.0	ns	1
External clock fall time	t_{fcp}	—	—	25.0	ns	1
SYNC output hold time	t_{HSYO}	30	—	—	ns	2, 3
SYNC output delay time	t_{DSY}	—	—	210	ns	2, 3
SYNC input hold time	t_{HSYI}	10	—	—	ns	2
SYNC input set-up time	t_{SSY}	—	—	180	ns	2

Notes: 1. Applied to external clock input terminal.

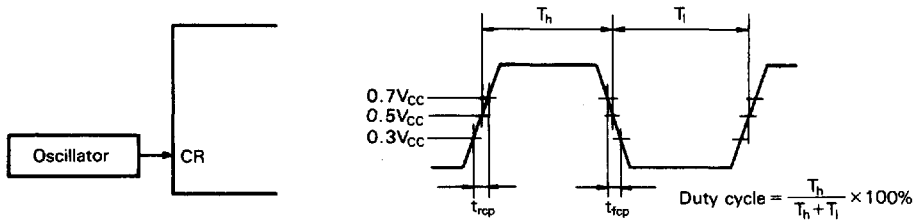

2. Applied to SYNC terminal.

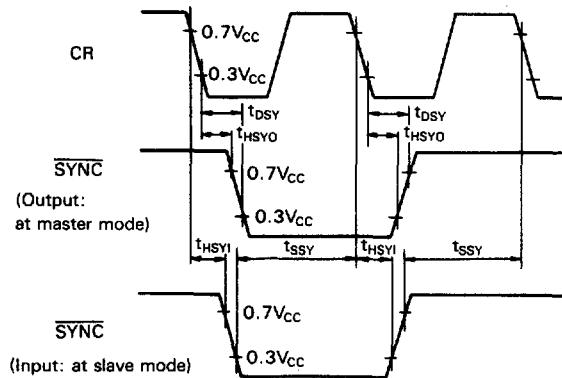

3. Testing load circuit.

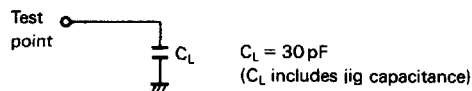

HITACHI

HD61830B

T-52-13-07

MPU Interface

Item	Symbol	Min	Typ	Max	Unit
Enable cycle time	t_{CYC}	1.0	—	—	μs
Enable pulse width	High level	t_{WEH}	0.45	—	μs
	Low level	t_{WEL}	0.45	—	μs
Enable rise time	t_{Er}	—	—	25	ns
Enable fall time	t_{Ef}	—	—	25	ns
Setup time	t_{AS}	140	—	—	ns
Data setup time	t_{DSW}	225	—	—	ns
Data delay time	t_{DDR}	—	—	225	ns (Note)
Data hold time	t_{DHW}	10	—	—	ns
Address hold time	t_{AH}	10	—	—	ns
Data hold time	t_{DH}	20	—	—	ns

Note: The following load circuit is connected for specification:

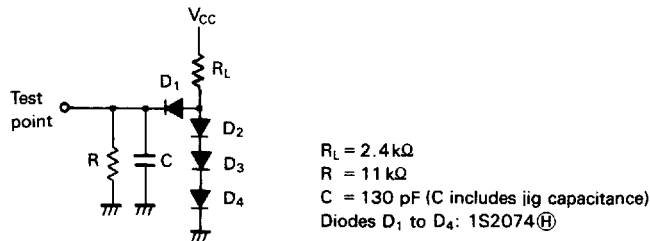
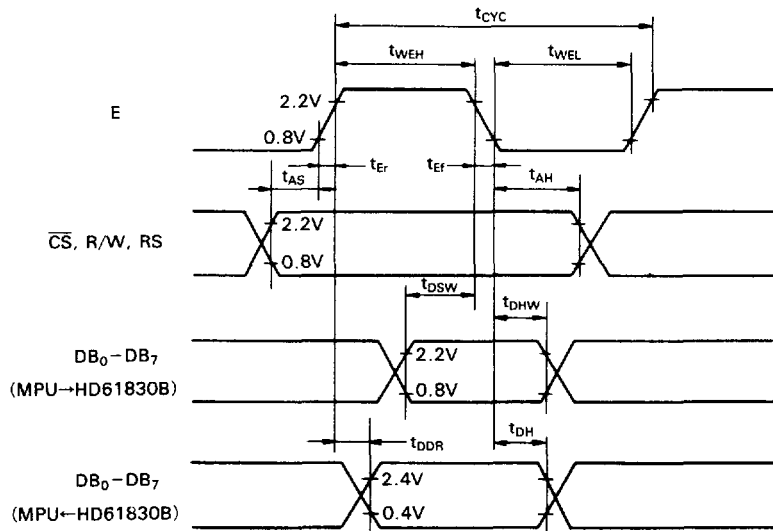

HITACHI

External RAM and ROM Interface

T-52-13-07

Item	Symbol	Min	Typ	Max	Unit	Note
MA0-MA15 delay time	t _{DMA}	—	—	300	ns	1, 2, 3
MA0-MA15 hold time	t _{HMA}	40	—	—	ns	1, 2, 3
CE delay time	t _{DCE}	—	—	300	ns	1, 2, 3
CE hold time	t _{HCE}	40	—	—	ns	1, 2, 3
OE delay time	t _{DOE}	—	—	300	ns	1, 3
OE hold time	t _{HOE}	40	—	—	ns	1, 3
MD output delay time	t _{DMD}	—	—	150	ns	1, 3
MD output hold time	t _{HMDW}	10	—	—	ns	1, 3
WE delay time	t _{DWE}	—	—	150	ns	1, 3
WE clock pules width	t _{WWE}	150	—	—	ns	1, 3
MD output high impedance time (1)	t _{ZMDF}	10	—	—	ns	1, 3
MD output high impedance time (2)	t _{ZMDR}	50	—	—	ns	1, 3
RD data set-up time	t _{SRD}	50	—	—	ns	2
RD data hold time	t _{HRD}	40	—	—	ns	2
MD data set-up time	t _{SMD}	50	—	—	ns	2
MD data hold time	t _{HMD}	40	—	—	ns	2

Notes: 1. RAM write timing

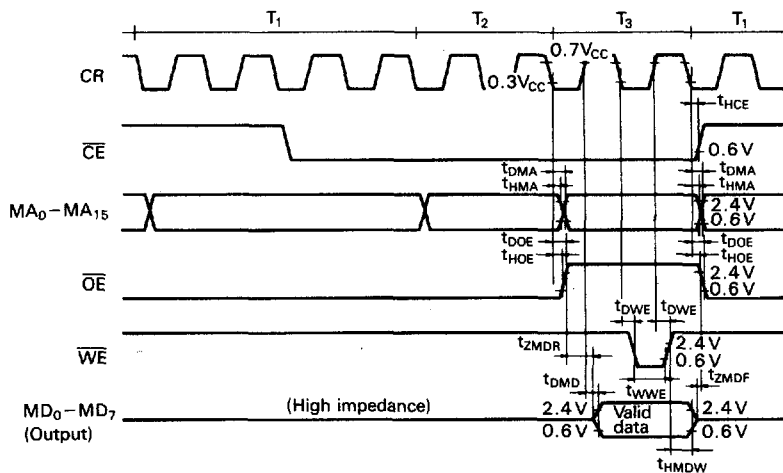

T1: Memory data refresh timing for upper screen
 T2: Memory data refresh timing for lower screen
 T3: Memory read/write timing

HITACHI

Notes: 2. ROM/RAM read timing

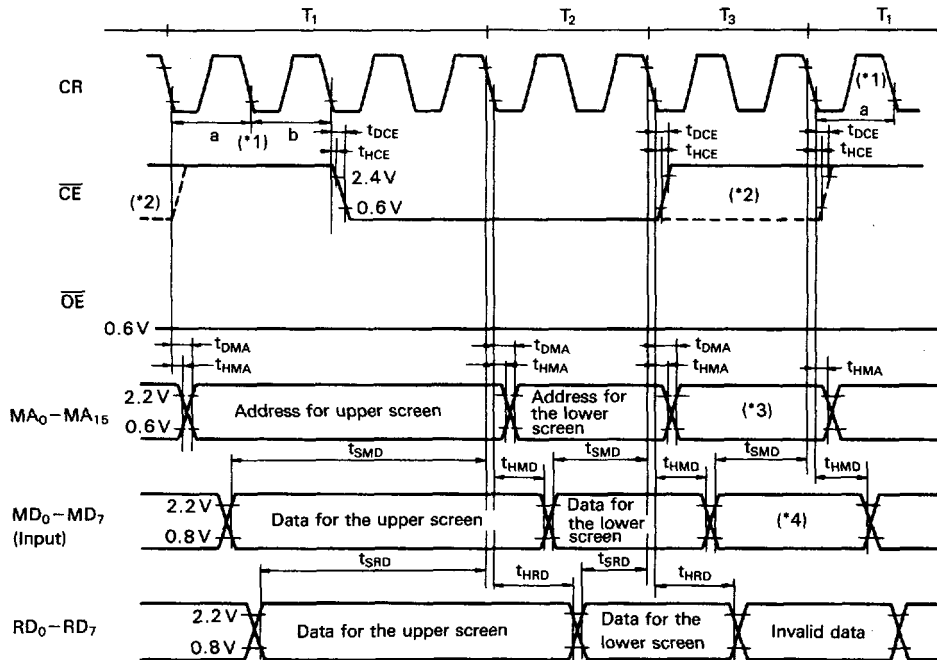

- *1 This figure shows the timing for $H_p = 8$.
 For $H_p = 7$, time shown by "b" becomes zero. For $H_p = 6$, time shown by "a" and "b" become zero.
 Therefore, the number of clock pulses during T1 become 4, 3, or 2 in the case of $H_p = 8$, $H_p = 7$, or $H_p = 6$ respectively.
- *2 The waveform for instructions with memory read is shown with a dash line. In other cases, the waveform shown with a solid line is generated.
- *3 When an instruction with RAM read/write is executed, the value of cursor address is output. In other cases, invalid data is output.
- *4 When an instruction with RAM read is executed, HD61830B latches the data at this timing. In other cases, this data is invalid.

3. Test load circuit

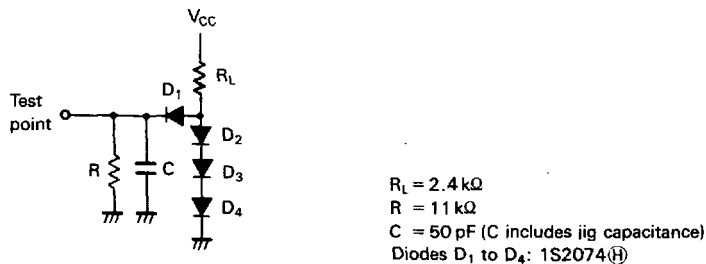

HITACHI

T-52-13-07

LCD Driver Interface

Item	Symbol	Min	Typ	Max	Unit	Note
Clock cycle time	t _{WCL2}	416	—	—	ns	1, 3
Clock pulse width (High level)	t _{WCH}	150	—	—	ns	1, 3
Clock pulse width (Low level)	t _{WCL}	150	—	—	ns	1, 3
Data delay time	t _{DD}	—	—	50	ns	1, 3
Data hold time	t _{DH}	100	—	—	ns	1, 3
Clock phase difference (1)	t _{CL1}	100	—	—	ns	1, 3
Clock phase difference (2)	t _{CL2}	100	—	—	ns	1, 3
Clock phase difference (3)	t _{CL3}	100	—	—	ns	1, 3
MA, MB delay time	t _{DM}	-200	—	200	ns	1, 3
FLM set-up time	t _{SF}	400	—	—	ns	2, 3
FLM hold time	t _{HF}	1000	—	—	ns	2, 3
MA set-up time	t _{SMA}	400	—	—	ns	2, 3
MA hold time	t _{HMA}	1000	—	—	ns	2, 3

5

HITACHI

Notes: 1.

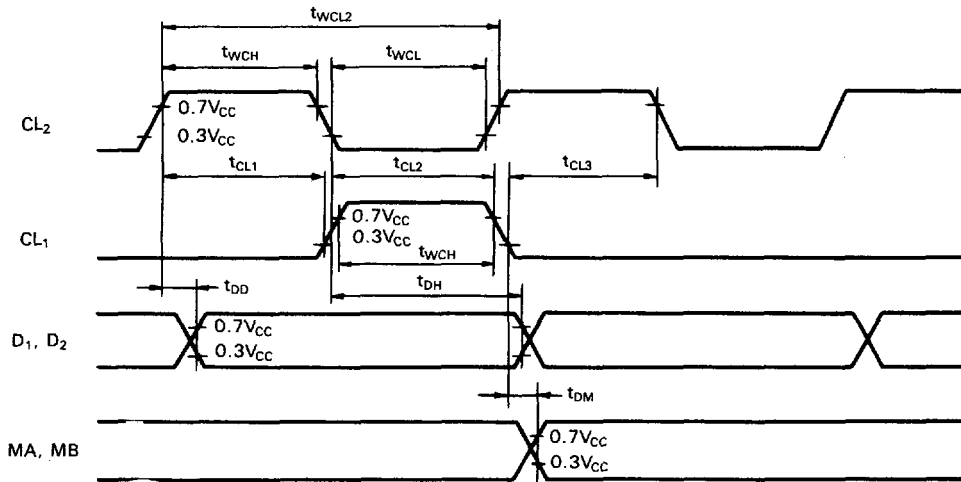

2.

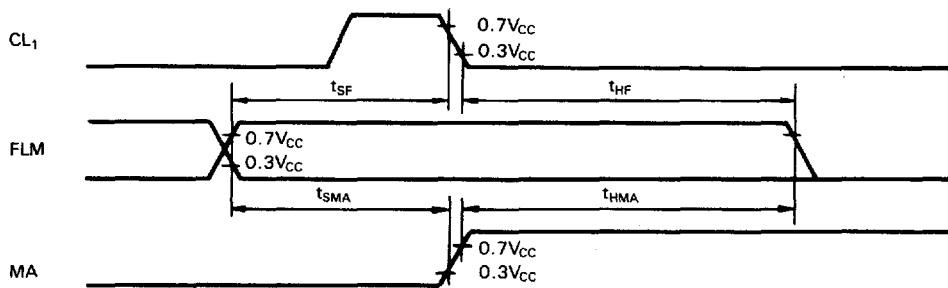

3. Test load circuit



$CL = 100 \text{ pF}$ (CL includes jig capacitance)

HITACHI

Display Control Instructions

Display is controlled by writing data into the instruction register and 13 data registers. The RS signal distinguishes the instruction register from the data registers. 8-bit data is written into the instruction register with RS = 1, and the data register code is specified. After that, the 8-bit data is written in the data register and the specified instruction is executed with RS = 0.

During the execution of the instruction, no new instruction can be accepted. Since the busy flag is set during this, read the busy flag and make sure it is 0 before writing the next instruction.

1. Mode control

Code "\$00" (hexadecimal) written into the instruction register specifies the mode control register.

Register	R/W	RS	DB7	DB6	DB5	DB4	DB3	DB2	DB1	DB0
Instruction reg.	0	1	0	0	0	0	0	0	0	0
Mode control reg.	0	0	0	0	Mode data					

DB5	DB4	DB3	DB2	DB1	DB0	Cursor/blink	CG	Graphic/character display	
I/O	I/O	0	0	0	0	Cursor off	Internal CG	Character display (Character mode)	
		0	1			Cursor on			
		1	0			Cursor off, Character blink			
		1	1			Cursor blink			
		0	0	1	Cursor off	External CG			
		0	1	Cursor on					
		1	0	Cursor off, character blink					
		1	1	Cursor blink					
		0	0	1	0				Graphic mode
		Display ON/OFF	Master/slave	Blink	Cursor	Graphic/character mode	Ext./Int. CG		

- 1: Master mode
0: Slave mode
- 1: Display ON
0: Display OFF

2. Set character pitch

V_p indicates the number of vertical dots per character. The space between the vertically-displayed characters is considered for determination. This value is meaningful only during character display (in the character mode) and becomes invalid in the graphic mode.

H_p indicates the number of horizontal dots per character in display, including the space between horizontally-displayed characters. In the graphic mode, the H_p indicates the number of bits of 1-byte display data to be displayed.

There are three H_p values (Table 1).

Register	R/W	RS	DB7	DB6	DB5	DB4	DB3	DB2	DB1	DB0
Instruction reg.	0	1	0	0	0	0	0	0	0	1
Character pitch reg.	0	0	(V _p - 1) binary				0	(H _p - 1) binary		

3. Set number of characters

H_N indicates the number of horizontal characters in the character mode or the number of horizontal bytes in the graphic mode. If the total sum of horizontal dots on the screen is taken as n ,

$$n = H_p \times H_N$$

H_N can be set to an even number from 2 to 128 (decimal).

Register	R/W	RS	DB7	DB6	DB5	DB4	DB3	DB2	DB1	DB0
Instruction reg.	0	1	0	0	0	0	0	0	1	0
Number-of-characters reg.	0	0	0	(H _N - 1) binary						

Table 1 H_p Values

H _p	DB2	DB1	DB0	Horizontal character pitch
6	1	0	1	6
7	1	1	0	7
8	1	1	1	8

HITACHI

4. Set number of time divisions (inverse of display duty ratio)

ratio.

N_x indicates the number of time divisions in multiplex display. $1/N_x$ is the display duty

A value of 1 to 128 (decimal) can be set to N_x .

Register	R/W	RS	DB7	DB6	DB5	DB4	DB3	DB2	DB1	DB0
Instruction reg.	0	1	0	0	0	0	0	0	1	1
Number-of-time shares reg.	0	0	0	(N _x - 1) binary						

5. Set cursor position

C_p indicates the position in a character where the cursor is displayed in the character mode. For example, in 5×7 dot font, the cursor is displayed under a character by specifying $C_p = 8$ (decimal). The cursor horizontal length is equal to the horizontal character pitch H_p . A value of 1 to 16 (decimal)

can be set to C_p . If a smaller value than the vertical character pitch V_p is set ($C_p \leq V_p$), and a character overlaps with the cursor, the cursor has higher priority of display (at cursor display on). If C_p is greater than V_p , no cursor is displayed. The cursor horizontal length is equal to H_p .

Register	R/W	RS	DB7	DB6	DB5	DB4	DB3	DB2	DB1	DB0
Instruction reg.	0	1	0	0	0	0	0	1	0	0
Cursor position reg.	0	0	0	0	0	0	(C _p - 1) binary			

6. Set display start low order address

Cause display start addresses to be written in the display start address registers. The display start address indicates a RAM address at which the data displayed at the top left end on the screen is stored. In the graphic mode,

the start address is composed of high/low order 16 bits. In the character display, it is composed of the lower 4 bits of high order address (DB₃-DB₀) and 8 bits of low order address. The upper 4 bits of high order address are ignored.

Register	R/W	RS	DB7	DB6	DB5	DB4	DB3	DB2	DB1	DB0
Instruction reg.	0	1	0	0	0	0	1	0	0	0
Display start address reg. (low order byte)	0	0	(Start low order address) binary							

Set display start high order address

Register	R/W	RS	DB7	DB6	DB5	DB4	DB3	DB2	DB1	DB0
Instruction reg.	0	1	0	0	0	0	1	0	0	1
Display start address reg. (high order byte)	0	0	(Start high order address) binary							

HITACHI

7. Set cursor address (low order) (RAM write low order address)

Cause cursor addresses to be written in the cursor address counters. The cursor address indicates an address for sending or receiving display data and character codes to or from the RAM.

That is, data at the address specified by the cursor address are read/written. In the character mode, the cursor is displayed at the character specified by the cursor address.

A cursor address consists of the low-order

address (8 bits) and the high-order address (8 bits). Satisfy the following requirements when setting the cursor address (Table 2).

The cursor address counter is a 16-bit up-counter with set and reset functions. When bit N changes from 1 to 0, bit N + 1 is incremented by 1. When setting the low order address, the LSB (bit 1) of the high order address is added by 1 if the MSB (bit 8) of the low order address changes from 1 to 0. Therefore, set both the low order address and the high order address as shown in table 2.

Register	R/W	RS	DB7	DB6	DB5	DB4	DB3	DB2	DB1	DB0
Instruction reg.	0	1	0	0	0	0	1	0	1	0
Cursor address counter (low order byte)	0	0	(Cursor low order address) binary							

Set cursor address (high order) (RAM write high order address)

Register	R/W	RS	DB7	DB6	DB5	DB4	DB3	DB2	DB1	DB0
Instruction reg.	0	1	0	0	0	0	1	0	1	1
Cursor address counter (high order byte)	0	0	(Cursor high order address) binary							

Table 2 Cursor Address Setting

Condition	Requirement
When you want to rewrite (set) both the low order address and the high order address.	Set the low order address and then set the high order address.
When you want to rewrite only the low order address.	Don't fail to set the high order address again after setting the low order address.
When you want to rewrite only the high order address.	Set the high order address. You don't have to set the low order address again.

HITACHI

8. Write display data

After the code "\$0C" is written into the instruction register with RS = 1, 8 bit data with RS = 0 should be written into the data

register. This data is transferred to the RAM specified by the cursor address as display data or character code. The cursor address is increased by 1 after this operation.

Register	R/W	RS	DB7	DB6	DB5	DB4	DB3	DB2	DB1	DB0
Instruction reg.	0	1	0	0	0	0	1	1	0	0
RAM	0	0	MSB (pattern data, character code) LSB							

9. Read display data

Data can be read from the RAM with RS = 0

after writing code "\$0C" into the instruction register. Figure 1 shows the read procedure.

Register	R/W	RS	DB7	DB6	DB5	DB4	DB3	DB2	DB1	DB0
Instruction reg.	0	1	0	0	0	0	1	1	0	1
RAM	1	0	MBS (pattern data, character code) LSB							

This instruction outputs the contents of data output register on the data bus (DB0 to DB7) and then transfers RAM data specified by the cursor address to the data output register, also increasing the cursor address by 1. After

setting the cursor address, correct data is not output at the first read but at the second one. Thus, make one dummy read when reading data after setting the cursor address.

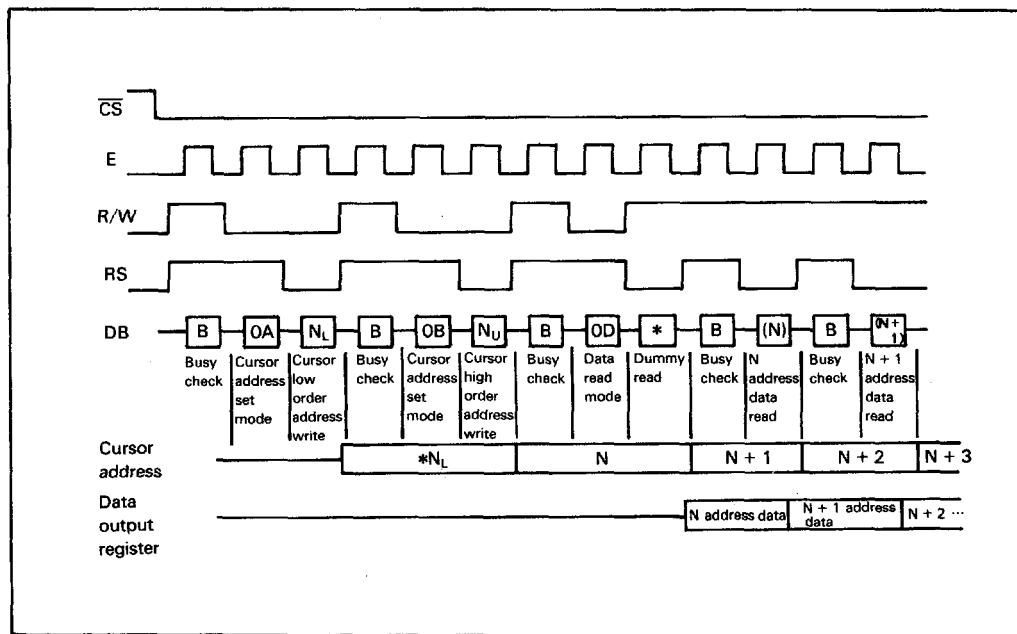

Figure 1 Read Procedure

HITACHI

10. Clear bit

The clear/set bit instruction sets 1 bit in a byte of display data RAM to 0 or 1, respectively. The position of the bit in a byte is specified by N_B and RAM address is specified

by cursor address. After the execution of the instruction, the cursor address is automatically increased by 1. N_B is a value from 1 to 8. $N_B = 1$ and $N_B = 8$ indicates LSB and MSB, respectively.

Register	R/W	RS	DB7	DB6	DB5	DB4	DB3	DB2	DB1	DB0
Instruction reg.	0	1	0	0	0	0	1	1	1	0
Bit clear reg.	0	0	0	0	0	0	0	(N _B - 1) binary		

Set bit

Register	R/W	RS	DB7	DB6	DB5	DB4	DB3	DB2	DB1	DB0
Instruction reg.	0	1	0	0	0	0	1	1	1	1
Bit set reg.	0	0	0	0	0	0	0	(N _B - 1) binary		

11. Read busy flag

When the read mode is set with $RS = 1$, the busy flag is output to DB7. The busy flag is set to 1 during the execution of any of the other instructions. After the execution, it is set to 0. The next instruction can be accepted. No instruction can be accepted when busy flag = 1. Before executing an instruction or writing data, perform a busy flag check to make

sure the busy flag is 0. When data is written in the register ($RS = 1$), busy flag doesn't change. Thus, no busy flag check is required just after the write operation into the instruction register with $RS = 1$.

The busy flag can be read without specifying any instruction register.

Register	R/W	RS	DB7	DB6	DB5	DB4	DB3	DB2	DB1	DB0
Busy flag	1	1	I/O	*						

T-52-13-07

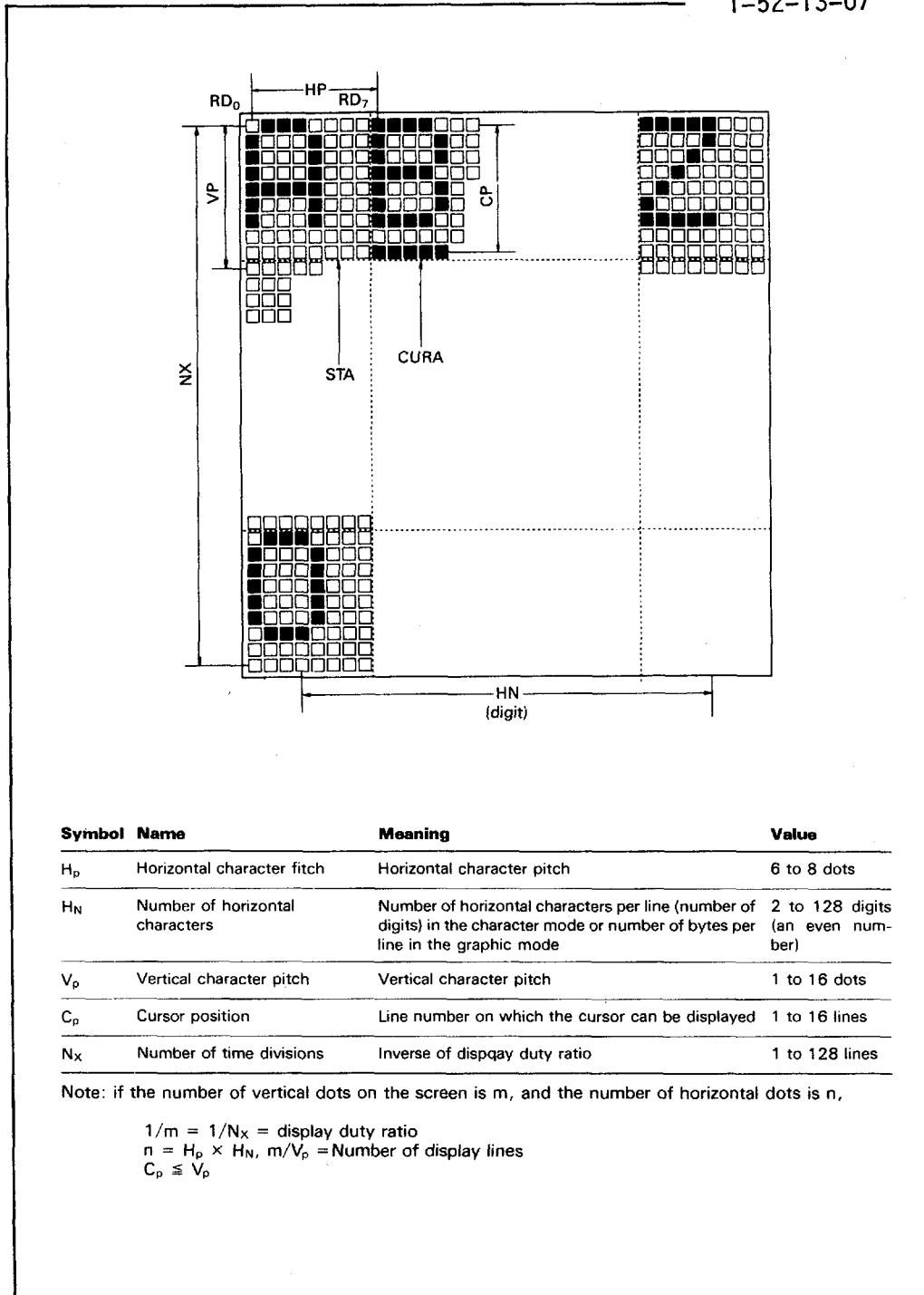

Symbol	Name	Meaning	Value
H _p	Horizontal character pitch	Horizontal character pitch	6 to 8 dots
H _N	Number of horizontal characters	Number of horizontal characters per line (number of digits) in the character mode or number of bytes per line in the graphic mode	2 to 128 digits (an even number)
V _p	Vertical character pitch	Vertical character pitch	1 to 16 dots
C _p	Cursor position	Line number on which the cursor can be displayed	1 to 16 lines
N _x	Number of time divisions	Inverse of display duty ratio	1 to 128 lines

Note: if the number of vertical dots on the screen is m, and the number of horizontal dots is n,

$$1/m = 1/N_x = \text{display duty ratio}$$

$$n = H_p \times H_N, m/V_p = \text{Number of display lines}$$

$$C_p \leq V_p$$

Figure 2 Display Variables

HITACHI

HD61830B

HITACHI/ (MCU/MPU)

50E D

4496204 0025785 T42

HITACHI

Display Mode

T-52-13-07

Display Mode	Display Data from MPU	RAM	Liquid Crystal Display Panel
Character display	Character code (8 bits)		<p>Hp: 6, 7, or 8 dots</p>
Graphic	Display pattern (8 bits)		<p>Hp: 8 dots</p>

HITACHI

Internal Character Generator Patterns and Character Codes

T-52-13-07

Higher Lower 4 bits 4 bits	0010	0011	0100	0101	0110	0111	1010	1011	1100	1101	1110	1111
xxx0000	0	1	2	3	4	5	6	7	8	9	A	B
xxx0001	C	D	E	F	G	H	I	J	K	L	M	N
xxx0010	O	P	Q	R	S	T	U	V	W	X	Y	Z
xxx0011	[]	{	}	~	^	_	+	=	&	*	%
xxx0100	@	#	\$	%	&	'	()	*	+	=	&
xxx0101	^	_	+	=	&	*	%	^	_	+	=	&
xxx0110	~	^	_	+	=	&	*	%	~	^	_	+
xxx0111	^	_	+	=	&	*	%	^	_	+	=	&
xxx1000	&	*	%	^	_	+	=	&	*	%	^	_
xxx1001	^	_	+	=	&	*	%	^	_	+	=	&
xxx1010	*	%	^	_	+	=	&	*	%	^	_	+
xxx1011	+	=	&	*	%	^	_	+	=	&	*	%
xxx1100	^	_	+	=	&	*	%	^	_	+	=	&
xxx1101	=	&	*	%	^	_	+	=	&	*	%	^
xxx1110	&	*	%	^	_	+	=	&	*	%	^	_
xxx1111	~	^	_	+	=	&	*	%	~	^	_	+

HD61830B

T-52-13-07

Application (Character Mode, External CG, Character Font 8 × 8)

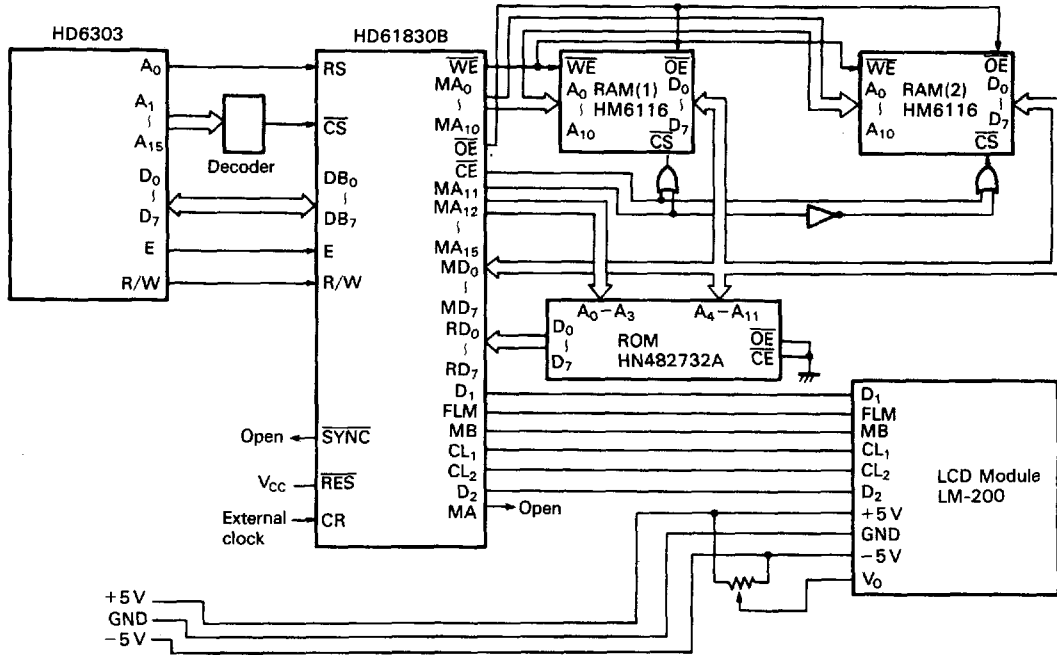

Application (Graphic Mode)

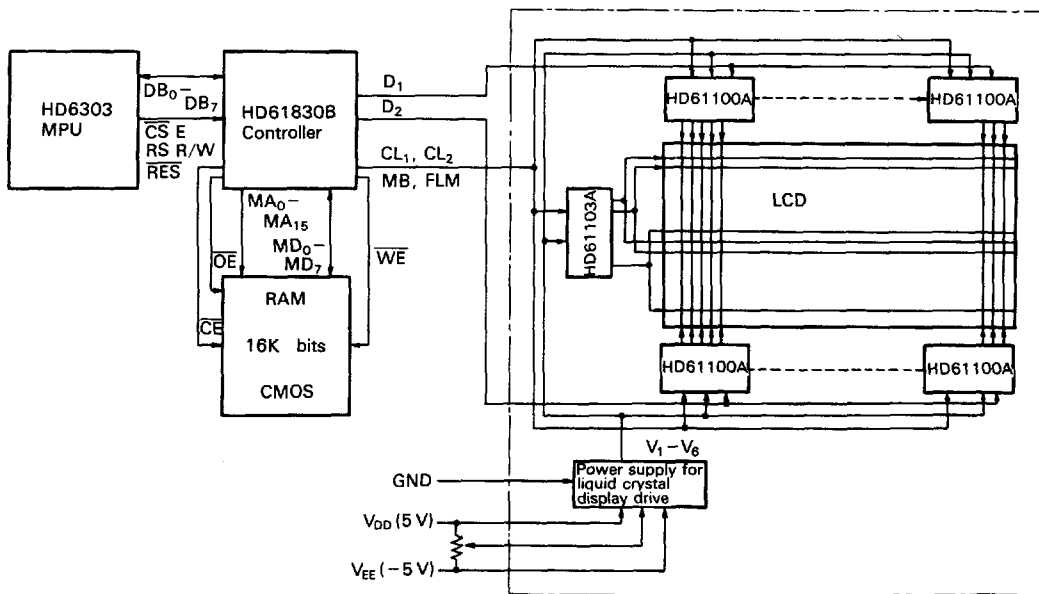

HITACHI

