

Radiation Hardened High Slew Rate Operational Amplifier

The HS-2510RH is a radiation hardened high performance operational amplifier which set the standard for maximum slew rate and wide bandwidth operation in moderately powered, internally compensated, monolithic devices. In addition to excellent dynamic characteristics, this dielectrically isolated amplifier also offers low offset current and high input impedance.

The $\pm 50V/ms$ minimum slew rate and fast settling time of the HS-2510RH are ideally suited for high speed D/A, A/D, and pulse amplification designs. The HS-2510RH superior bandwidth and 750kHz minimum full power bandwidth are extremely useful in RF and video applications. To insure compliance with slew rate and transient response specifications, all devices are 100% tested for AC performance characteristics over full temperature limits. To improve signal conditioning accuracy, the HS-2510RH provides a maximum offset current of 25nA and a minimum input impedance of 50M Ω , both at 25°C, as well as offset voltage trim capability.

Specifications for Rad Hard QML devices are controlled by the Defense Supply Center in Columbus (DSCC). The SMD numbers listed here must be used when ordering.

Detailed Electrical Specifications for these devices are contained in SMD 5962-95686. A "hot-link" is provided on our homepage for downloading.

Features

- Electrically Screened to SMD # 5962-95686
- QML Qualified per MIL-PRF-38535 Requirements
- High Slew Rate 50V/ μ s (Min), 65V/ μ s (Typ)
- Wide Power Bandwidth 750kHz (Min)
- Low Offset Current 25nA (Min), 10nA (Typ)
- High Input Impedance 50M Ω (Min), 100M Ω (Typ)
- Wide Small Signal Bandwidth 12MHz (Typ)
- Fast Settling Time (0.1% of 10V Step) 250ns (Typ)
- Low Quiescent Supply Current 6mA (Max)
- Internally Compensated For Unity Gain Stability
- Total Gamma Dose 10kRAD(Si)

Applications

- Data Acquisition Systems
- RF Amplifiers
- Video Amplifiers
- Signal Generators
- Pulse Amplification

Ordering Information

ORDERING NUMBER	INTERNAL MKT. NUMBER	TEMP. RANGE (°C)
5962D9568601VPA	HS7-2510RH-Q	-55 to 125
5962D9568601VPC	HS7B-2510RH-Q	-55 to 125
5962D9568601VXC	HS9-2510RH-Q	-55 to 125

Pinouts

HS-2510RH GDIP1-T8 (CERDIP)
OR
HS-2510RH CDIP2-T8 (SBDIP)
TOP VIEW

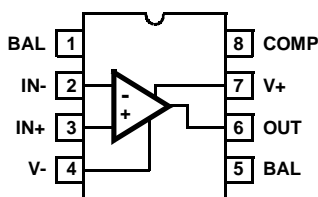

HS-2510RH
CDFP3-F14 (FLATPACK)
TOP VIEW

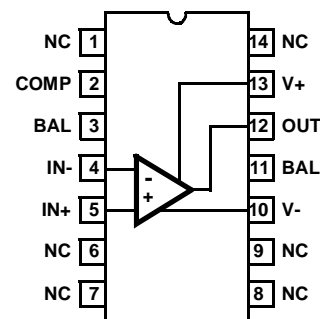

Test Circuit

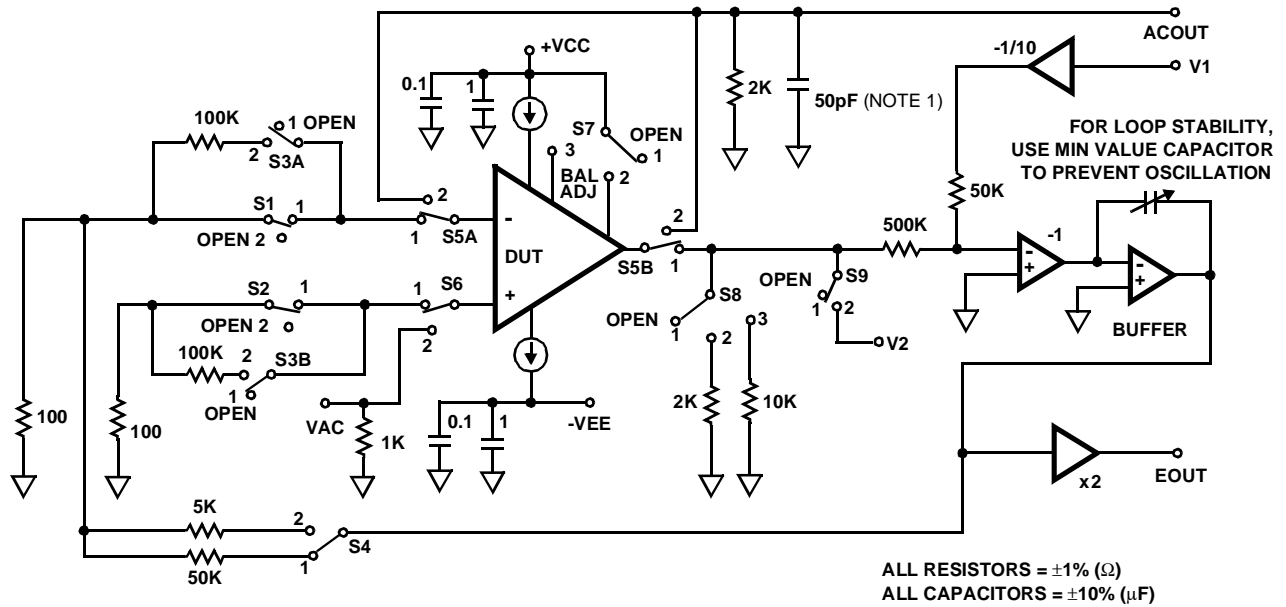

NOTE:

- 1. Includes stray capacitances.

FIGURE 1. SIMPLIFIED TEST CIRCUIT

Test Circuit and Waveforms

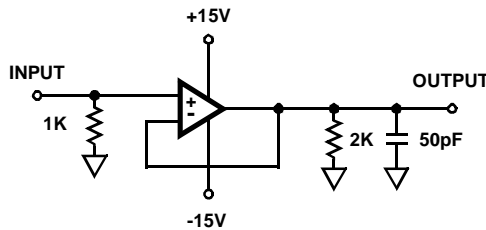
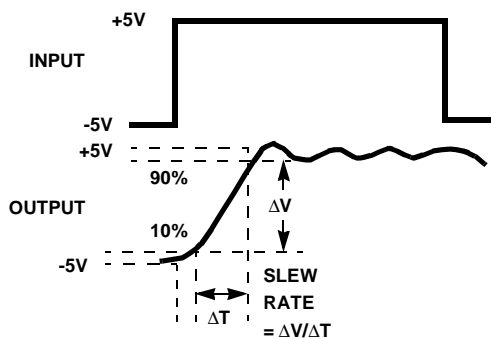
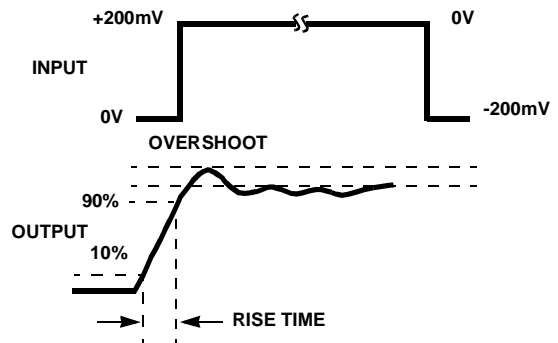

FIGURE 2. SIMPLIFIED TEST CIRCUIT



NOTE: Measured on both positive and negative transitions. Capacitance at Compensation pin should be minimized.

FIGURE 3. SLEW RATE WAVEFORM



NOTE: Measured on both positive and negative transitions. Capacitance at Compensation pin should be minimized.

FIGURE 4. TRANSIENT RESPONSE WAVEFORM

Typical Performance Curves Unless Otherwise Specified: $T_A = 25^\circ\text{C}$, $V_{\text{SUPPLY}} = \pm 15\text{V}$

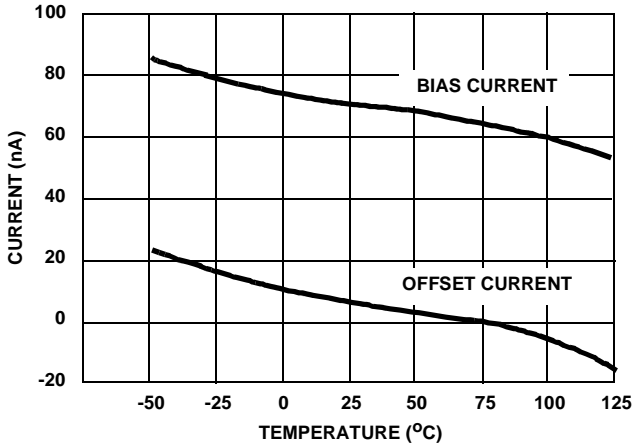

FIGURE 5. INPUT BIAS AND OFFSET CURRENT vs TEMPERATURE

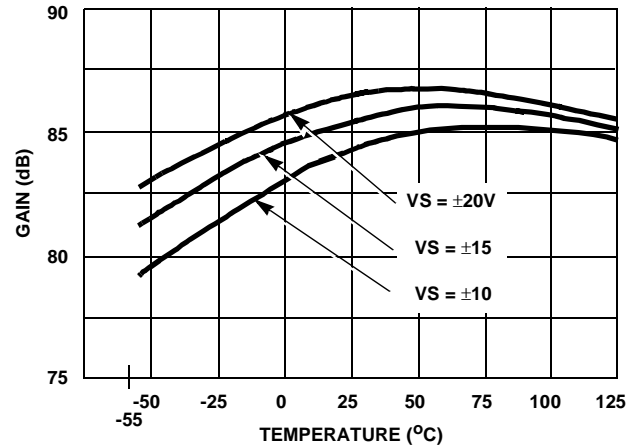

FIGURE 6. OPEN LOOP VOLTAGE GAIN vs TEMPERATURE

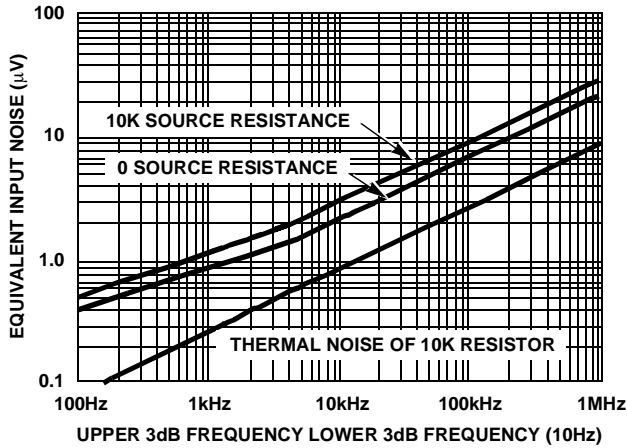

FIGURE 7. EQUIVALENT INPUT NOISE vs BANDWIDTH

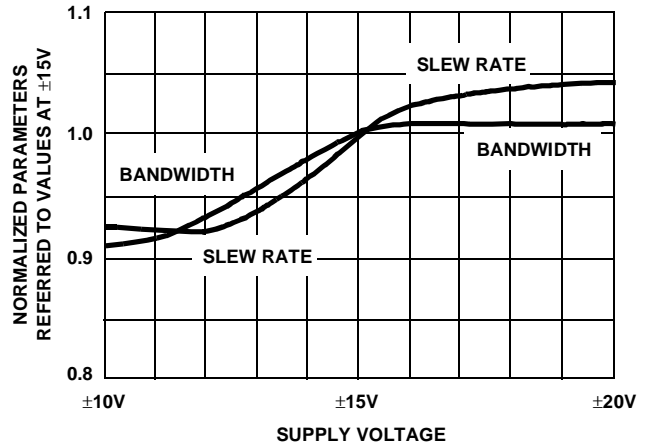

FIGURE 8. NORMALIZED AC PARAMETERS vs SUPPLY VOLTAGE AT 25°C

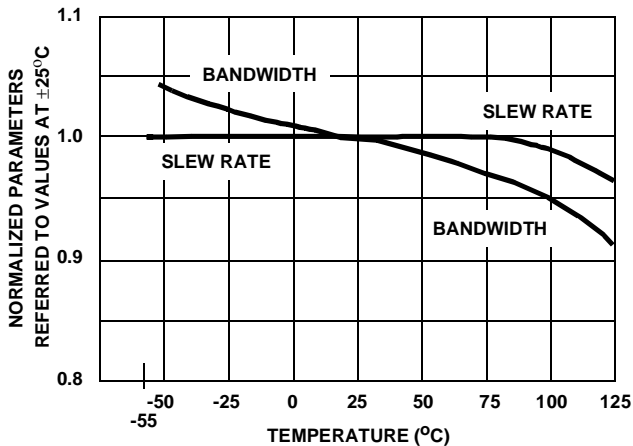

FIGURE 9. NORMALIZED AC PARAMETERS vs TEMPERATURE

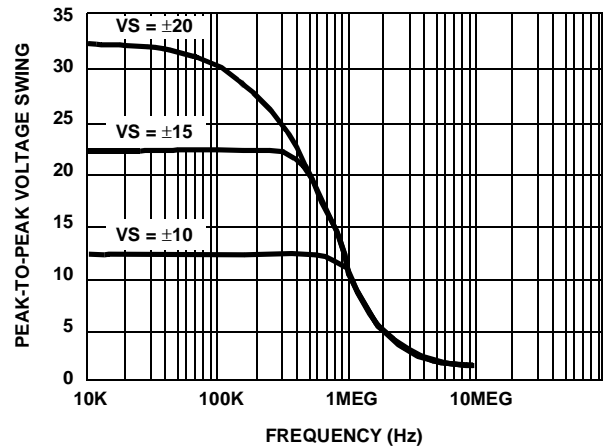
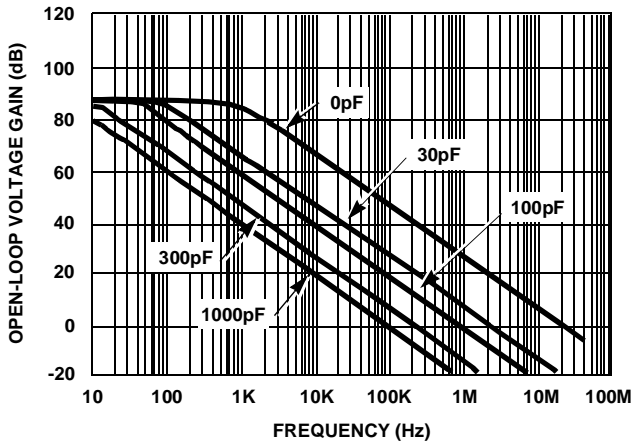

FIGURE 10. OUTPUT VOLTAGE SWING vs FREQUENCY AT 25°C

Typical Performance Curves Unless Otherwise Specified: $T_A = 25^\circ\text{C}$, $V_{\text{SUPPLY}} = \pm 15\text{V}$ (Continued)



NOTE: External compensation components are not required for stability, but may be added to reduce bandwidth, if desired.

FIGURE 11. OPEN LOOP FREQUENCY RESPONSE FOR VARIOUS VALUES OF CAPACITORS FROM COMPENSATION PIN TO GROUND

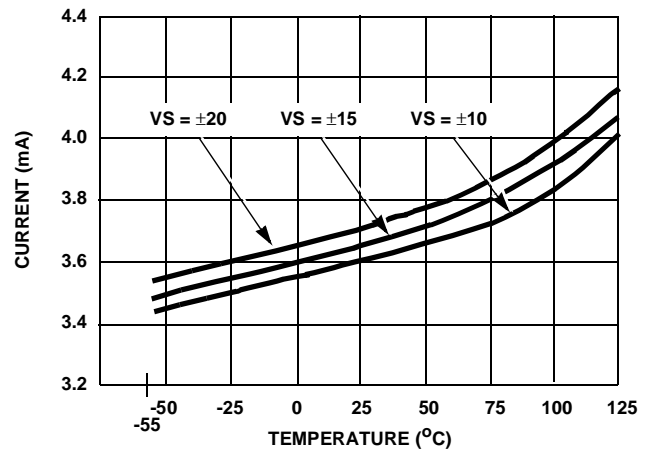

FIGURE 12. POWER SUPPLY CURRENT vs TEMPERATURE

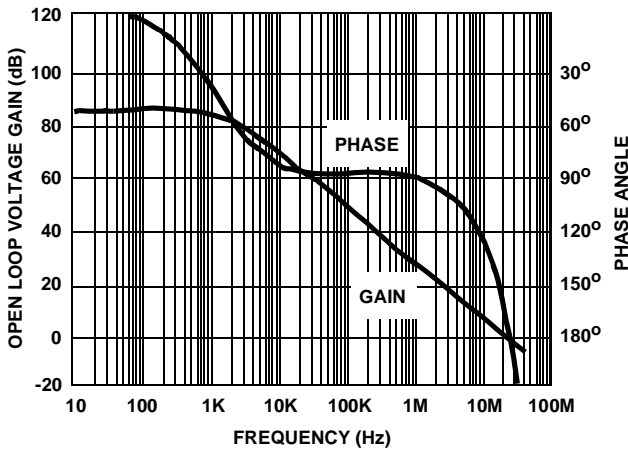
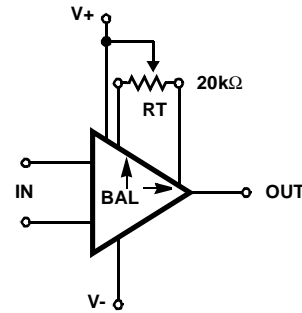

FIGURE 13. OPEN LOOP GAIN AND PHASE RESPONSE vs FREQUENCY



NOTE: Tested offset adjustment is $|V_{\text{OS}} + 1\text{mV}|$ minimum referred to output typical range is $\pm 8\text{mV}$ for $R_T = 20\text{k}\Omega$.

FIGURE 14. SUGGESTED V_{OS} ADJUSTMENT

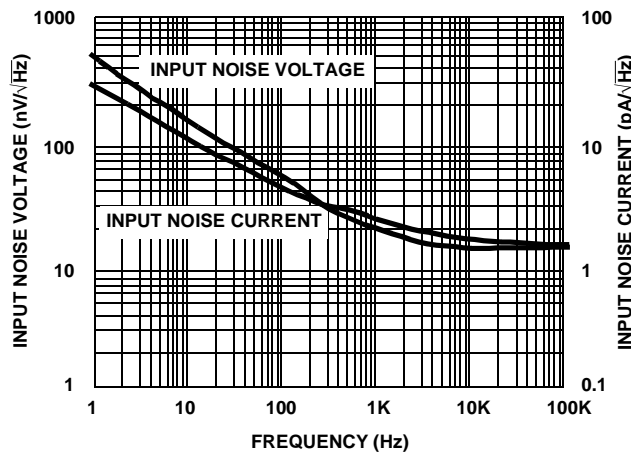
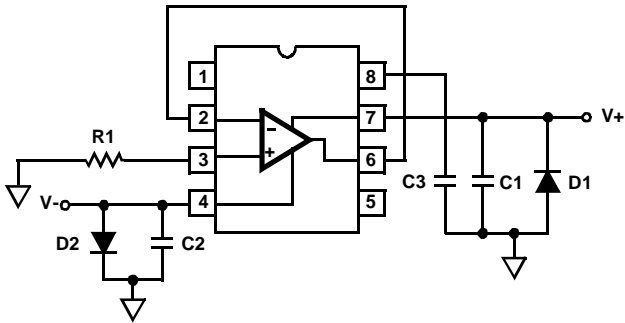

FIGURE 15. INPUT NOISE DENSITY vs FREQUENCY

Burn-In Circuits

HS7-2510RH CERDIP



NOTES:

2. R1 = 1MΩ, ±5%, 1/4W (Min)
3. C1 = C2 = 0.01μF/Socket (Min) or 0.1μF/Row (Min)
4. C3 = 0.01μF/Socket (10%)
5. D1 = D2 = 1N4002 or Equivalent (Per Board)
6. |(V+) - (V-)| = 30V

HS9-2510RH CERAMIC FLATPACK

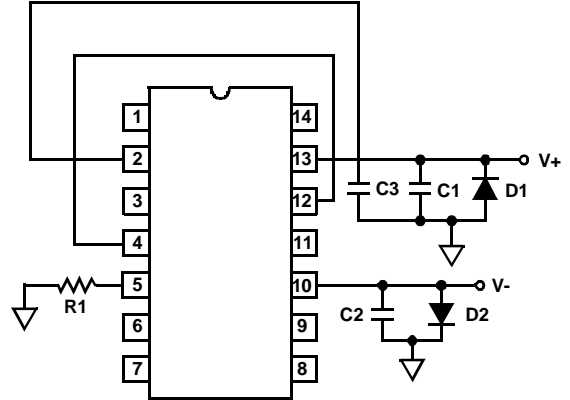

NOTES:

7. R1 = 1MΩ, ±5%, 1/4W (Min)
8. C1 = C2 = 0.01μF/Socket (Min) or 0.1μF/Row (Min)
9. C3 = 0.01μF/Socket (±10%)
10. D1 = D2 = 1N4002 or Equivalent (Per Board)
11. |(V+) - (V-)| = 31V ±1V

Irradiation Circuit

HS7-2510RH

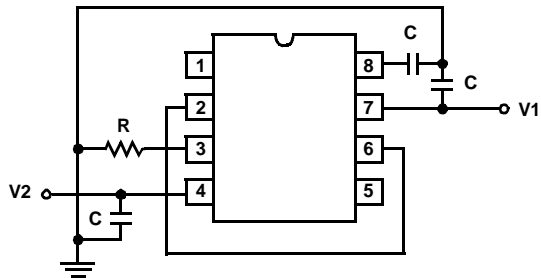

NOTES:

12. V1 = +15V ±10%
13. V2 = -15V ±10%
14. R = 1MΩ ±5%
15. C = 0.1μF ±10%

Schematic Diagram

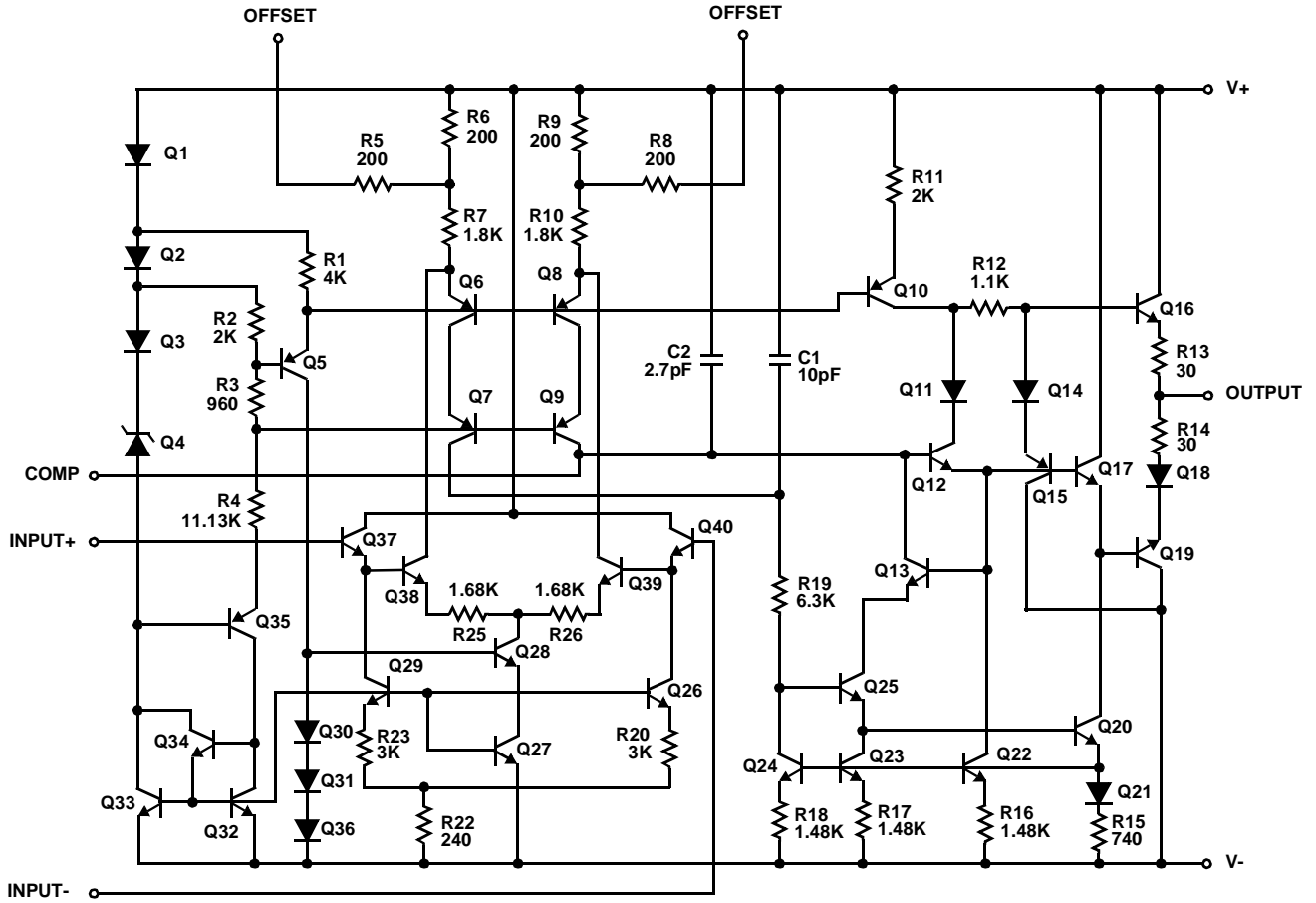

Die Characteristics

DIE DIMENSIONS:

65 mils x 57 mils x 19 mils
(1660µm x 1950µm x 483µm)

INTERFACE MATERIALS:

Glassivation:

Type: Nitride
Thickness: 7kÅ ±0.7kÅ

Top Metallization:

Type: Aluminum
Thickness: 16kÅ ±2kÅ

Substrate:

Linear Bipolar, DI

Backside Finish:

Silicon

ASSEMBLY RELATED INFORMATION:

Substrate Potential (Powered Up):

Unbiased

ADDITIONAL INFORMATION:

Worst Case Current Density:

<2 x 10⁵A/cm²

Transistor Count:

40

Die Attach:

Temperature: CERDIP 460°C (Max)

Metallization Mask Layout

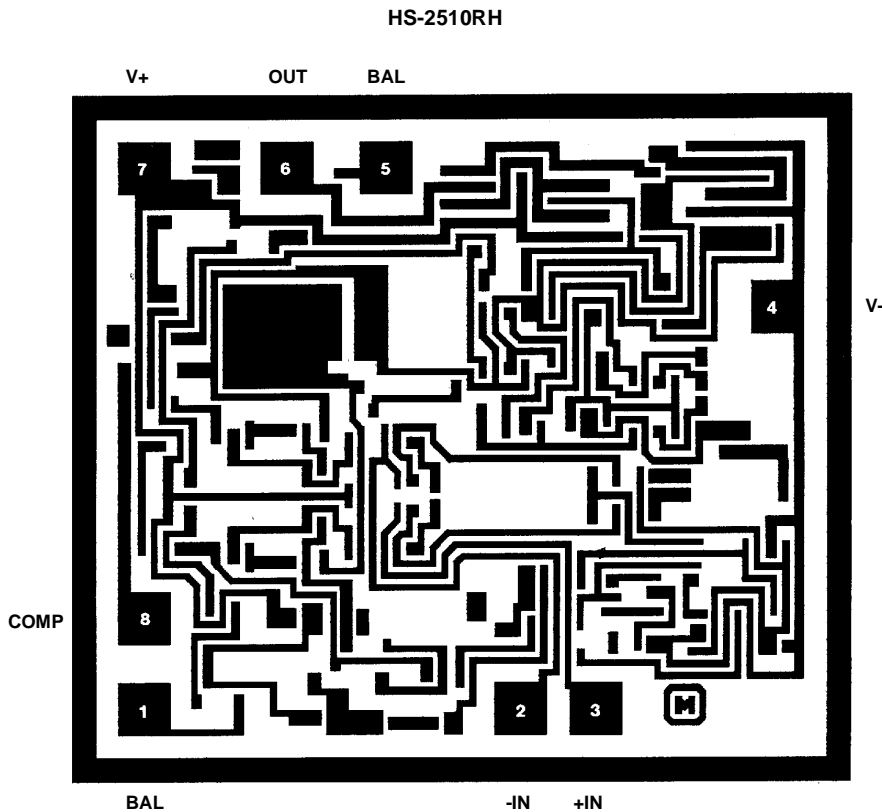

All Intersil U.S. products are manufactured, assembled and tested utilizing ISO9000 quality systems. Intersil Corporation's quality certifications can be viewed at www.intersil.com/design/quality

Intersil products are sold by description only. Intersil Corporation reserves the right to make changes in circuit design, software and/or specifications at any time without notice. Accordingly, the reader is cautioned to verify that data sheets are current before placing orders. Information furnished by Intersil is believed to be accurate and reliable. However, no responsibility is assumed by Intersil or its subsidiaries for its use; nor for any infringements of patents or other rights of third parties which may result from its use. No license is granted by implication or otherwise under any patent or patent rights of Intersil or its subsidiaries.

For information regarding Intersil Corporation and its products, see www.intersil.com