

MAXIM

Chopper Stabilized Operational Amplifier

ICL7650/7650B

General Description

The Maxim ICL7650 is a chopper-stabilized amplifier, ideal for low-level signal processing applications. Featuring high performance and versatility, this device combines low input offset voltage, low input bias current, wide bandwidth and exceptionally low drift over time and temperature. Low offset is achieved through a nulling scheme that provides continuous error correction. A nulling amplifier alternately nulls itself and the main amplifier. The result is an input offset voltage that is held to a minimum over the entire operating temperature range.

The ICL7650B is an exact replacement for the Intersil ICL7650B. This device has a maximum offset voltage of $10\mu\text{V}$, a maximum input offset voltage temperature coefficient of $0.1\mu\text{V}/^\circ\text{C}$, and a maximum bias current of 20pA ; all specified over the commercial temperature range.

A 14 lead version is available which can be used with either an internal or external clock. The 14 lead version has an output voltage clamp circuit to minimize overload recovery time.

Applications

Condition Amplifier	Thermocouples
Precision Amplifier	Thermistors
Instrumentation Amplifier	Strain Gauges

Pin Configuration

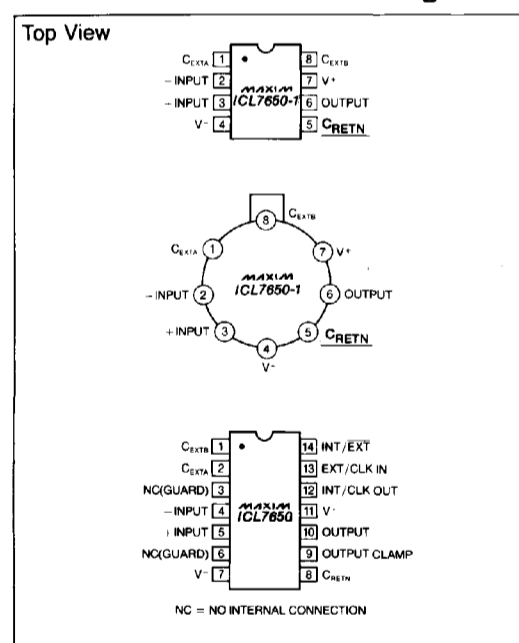

Features

- ◆ Improved 2nd Source! (See 3rd page for "Maxim Advantage™").
- ◆ Lower Supply Current: 2.0 mA
- ◆ Low Offset Voltage: $1\mu\text{V}$
- ◆ No Offset Voltage Trimming Needed
- ◆ High Gain, CMRR and PSRR (120 dB min)
- ◆ Lower Offset Drift With Time and Temperature
- ◆ Extended Common Mode Voltage Range
- ◆ Low DC Input Bias Current: 10pA
- ◆ Monolithic, Low Power CMOS Design

Ordering Information

PART	TEMP. RANGE	PACKAGE
ICL7650CPD	0°C to $+70^\circ\text{C}$	14 Lead Plastic DIP
ICL7650CSD	0°C to $+70^\circ\text{C}$	14 Lead Slim S.O.
ICL7650JJD	-20°C to $+85^\circ\text{C}$	14 Lead Cerdip
ICL7650MJD	-55°C to $+125^\circ\text{C}$	14 Lead Cerdip
ICL7650CPA-1	0°C to $+70^\circ\text{C}$	8 Lead Plastic DIP
ICL7650CSA-1	0°C to $+70^\circ\text{C}$	8 Lead Slim S.O.
ICL7650CTV-1	0°C to $+70^\circ\text{C}$	8 Lead TO-99 Metal Can
ICL7650JA-1	-20°C to $+85^\circ\text{C}$	8 Lead Cerdip
ICL7650MTV-1	-55°C to $+125^\circ\text{C}$	8 Lead Cerdip
ICL7650C/D	0°C to $+70^\circ\text{C}$	Dice
ICL7650BCPD	0°C to $+70^\circ\text{C}$	14 Lead Plastic DIP
ICL7650BCSD	0°C to $+70^\circ\text{C}$	14 Lead Slim S.O.
ICL7650BCPA-1	0°C to $+70^\circ\text{C}$	8 Lead Plastic DIP
ICL7650BCSA-1	0°C to $+70^\circ\text{C}$	8 Lead Slim S.O.
ICL7650BCTV-1	0°C to $+70^\circ\text{C}$	8 Lead TO-99 Metal Can
ICL7650BC/D	0°C to $+70^\circ\text{C}$	Dice

Typical Operating Circuit

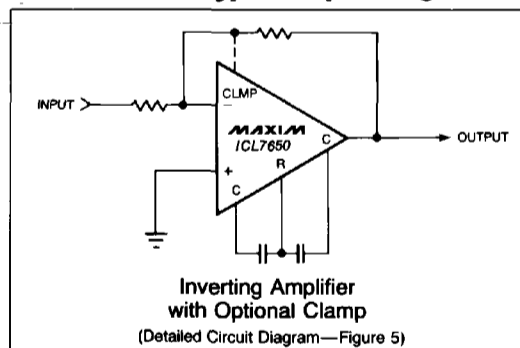

The "Maxim Advantage™" signifies an upgraded quality level. At no additional cost we offer a second-source device that is subject to the following: guaranteed performance over temperature along with tighter test specifications on many key parameters; and device enhancements, when needed, that result in improved performance without changing the functionality.

MAXIM

Maxim Integrated Products 1

Call toll free 1-800-998-8800 for free samples or literature.

Chopper Stabilized Operational Amplifier

ABSOLUTE MAXIMUM RATINGS

Total Supply Voltage (V^+ to V^-) 18Volts
 Input Voltage ($V^+ + 0.3$) to ($V^- - 0.3$) Volts
 Storage Temp. Range -65°C to 160°C
 Operating Temp. Range See Note 1
 Lead Temperature (Soldering, 10 sec) 300°C
 Voltage on oscillator control pins V^+ to V^-
 except EXT CLOCK IN: ($V^+ + 0.3$) to ($V^- - 6.0$) Volts
 Duration of Output short circuit Indefinite
 Current into any pin 10mA
 —while operating (Note 4) $100\mu\text{A}$

Cont. Total Power Dissipation ($T_A = 25^\circ\text{C}$)
 CERDIP Package 500mW
 Plastic Package 375mW
 TO-99 Metal Can 250mW
 Small Outline 350mW

Stresses above those listed under "Absolute Maximum Ratings" may cause permanent damage to the device. These are stress ratings only and functional operation of the device at these or any other conditions above those indicated in the operational sections of the specifications is not implied. Exposure to absolute maximum rating conditions for extended periods may affect device reliability.

ELECTRICAL CHARACTERISTICS — ICL7650

($V^+ = +5\text{V}$, $V^- = -5\text{V}$, $T_A = 25^\circ\text{C}$, Test Circuit, Unless Noted)

PARAMETER	SYMBOL	TEST CONDITIONS	MIN.	LIMITS TYP.	MAX.	UNIT
Input Offset Voltage	V_{OS}	$T_A = +25^\circ\text{C}$ $-55^\circ\text{C} < T_A < +85^\circ\text{C}$ $-55^\circ\text{C} < T_A < +125^\circ\text{C}$		± 0.7 ± 1.0	± 5 5.0	μV
Average Temp. Coefficient of Input Offset Voltage	ΔV_{OS} ΔT	$-20^\circ\text{C} < T_A < +85^\circ\text{C}$		0.01 50	0.05	$\mu\text{V}/^\circ\text{C}$
Input Bias Current (doubles every 10°C)	I_{BIAS}	$T_A = +25^\circ\text{C}$ $0^\circ\text{C} < T_A < +70^\circ\text{C}$ $-20^\circ\text{C} < T_A < +85^\circ\text{C}$		1.5 35 100	10	pA
Input Offset Current	I_{OS}	$T_A = 25^\circ\text{C}$		0.5		pA
Input Resistance	R_{IN}			10^{12}		Ω
Large Signal Voltage Gain	A_{VOL}	$R_L = 10\text{k}\Omega$	1×10^6	5×10^6		V/V
Output Voltage Swing (Note 3)	V_{OUT}	$R_L = 10\text{k}\Omega$ $R_L = 100\text{k}\Omega$	± 4.7	± 4.85 ± 4.95		V
Common Mode Voltage Range	CMVR		-5.0	-5.2 to +2.0	1.6	V
Common Mode Rejection Ratio	CMRR	CMVR = -5V to +1.6	120	130		dB
Power Supply Rejection Ratio	PSRR	$\pm 3\text{V}$ to $\pm 8\text{V}$	120	130		dB
Input Noise Voltage	e_{npp}	$R_S = 100\Omega$ 0 to 10Hz		2		$\mu\text{Vp-p}$
Input Noise Current	I_n	$f = 10\text{Hz}$		0.01		$\text{pA}/\sqrt{\text{Hz}}$
Unity Gain Bandwidth	GBW			2.0		MHz
Slow Rate	SR	$C_L = 50\text{pF}$, $R_L = 10\text{k}\Omega$		2.5		$\text{V}/\mu\text{s}$
Rise Time	t_r			0.2		μs
Overshoot				20		%
Operating Supply Range	V^+ to V^-		4.5		16	V
Supply Current	I_{SUPP}	no load		2.0	3.5	mA
Internal Chopping Frequency	f_{ch}	pins 12-14 open (DIP)	120	200	375	Hz
Clamp ON Current (note 2)		$R_L = 100\text{k}\Omega$	25	70	200	μA
Clamp OFF Current (note 2)		$-4.0\text{V} < V_{OUT} < +4.0\text{V}$		1		pA
Offset Voltage vs Time				100		$\text{nV}/\sqrt{\text{month}}$

NOTE 1: Operating temperature range for M series parts is -55°C to $+125^\circ\text{C}$, for I series is -20°C to $+85^\circ\text{C}$, for C series is 0°C to $+70^\circ\text{C}$

NOTE 2: See OUTPUT CLAMP under detailed description.

NOTE 3: OUTPUT CLAMP not connected. See typical characteristic curves for output swing vs clamp current characteristics.

NOTE 4: Limiting input current to $100\mu\text{A}$ is recommended to avoid latch-up problems. Typically 1mA is safe, however this is not guaranteed.

NOTE 5: $I_{OS} = 2 \cdot I_{BIAS}$

The electrical characteristics above are a reproduction of a portion of Intersil's copyrighted (1983/1984) data book. This information does not constitute any representation by Maxim that Intersil's products will perform in accordance with these specifications. The "Electrical Characteristics Table" along with descriptive excerpts from the original manufacturer's data sheet have been included in this data sheet solely for comparative purposes



Chopper Stabilized Operational Amplifier

- ◆ Lower Supply Current
- ◆ Key Parameters Guaranteed over Temperature
- ◆ Extended Common Mode Voltage Range
- ◆ Characterized over Military Temperature Range
- ◆ Significantly Enhanced "ESD" Protection (Note 6)
- ◆ Maxim Quality and Reliability

ICL7650/7650B

ABSOLUTE MAXIMUM RATINGS This device conforms to the Absolute Maximum Ratings on adjacent page.

ELECTRICAL CHARACTERISTICS The ICL7650 specifications below satisfy or exceed all "tested" parameters on adjacent page. ($V^+ = +5V$, $V^- = -5V$, $T_A = 25^\circ C$, Test Circuit, unless Noted.)

PARAMETER	SYMBOL	CONDITIONS	MIN	TYP	MAX	UNITS
Input Offset Voltage	V_{os}	$T_A = +25^\circ C$, ICL7650		± 0.7	± 5.0	μV
		$T_A = +25^\circ C$, ICL7650B		± 1.0	± 10	μV
		$0^\circ C \leq T_A \leq +70^\circ C$, ICL7650 (Note 7)		± 1.0	± 10	μV
		$-20^\circ C \leq T_A \leq +85^\circ C$, ICL7650 (Note 7)		± 1.0	± 10	μV
		$-55^\circ C \leq T_A \leq +125^\circ C$, ICL7650 (Note 7)		± 1.0	± 10	μV
Average Temperature Coefficient of Input Offset Voltage (Note 7)	$\frac{\Delta V_{os}}{\Delta T}$	$0^\circ C \leq T_A \leq +70^\circ C$, ICL7650		0.01	0.05	$\mu V/^\circ C$
		$0^\circ C \leq T_A \leq +70^\circ C$, ICL7650B		0.01	0.1	$\mu V/^\circ C$
		$-20^\circ C \leq T_A \leq +85^\circ C$, ICL7650		0.01	0.05	$\mu V/^\circ C$
		$-55^\circ C \leq T_A \leq +85^\circ C$, ICL7650		0.01	0.05	$\mu V/^\circ C$
		$+85^\circ C \leq T_A \leq +125^\circ C$, ICL7650		0.25	1.5	$\mu V/^\circ C$
Input Bias Current	I_b	$T_A = +25^\circ C$, ICL7650		4	10	pA
		$T_A = +25^\circ C$, ICL7650B		12	20	pA
		$0^\circ C \leq T_A \leq +70^\circ C$		20	100	pA
		$-20^\circ C \leq T_A \leq +85^\circ C$		50	200	pA
		$-55^\circ C \leq T_A \leq +125^\circ C$		0.3	10	nA
Input Resistance	R_{in}		10^{12}		Ω	
Large Signal Voltage Gain	A_{VOL}	$R_L = 10k\Omega$, $T_A = +25^\circ C$	1×10^6	5×10^6		V/V
		$0^\circ C \leq T_A \leq +70^\circ C$	0.5×10^6			V/V
		$-20^\circ C \leq T_A \leq +85^\circ C$	0.5×10^6			V/V
		$-55^\circ C \leq T_A \leq +125^\circ C$	0.2×10^6			V/V
Output Voltage Swing (Note 3)	V_{OUT}	$R_L = 10k\Omega$ $R_L = 100k\Omega$	± 4.7	± 4.85 ± 4.95		V
Common Mode Voltage Range	CMVR	$0^\circ C \leq T_A \leq +70^\circ C$	-5.0	-5.2 to 3.0	2.5	V
		$-20^\circ C \leq T_A \leq +85^\circ C$	-5.0	-5.2 to 3.0	2.5	V
		$-55^\circ C \leq T_A \leq +125^\circ C$	-4.5	-4.8 to 3.0	2.5	V
Common Mode Rejection Ratio	CMRR	CMVR = -5V to +2.5V	120	130		dB
Power Supply Rejection Ratio	PSRR	$\pm 3V$ to $\pm 8V$	120	130		dB
Input Noise Voltage	e_{n-p-p}	$R_s = 100\Omega$ 0 to 10Hz		2		μV_{p-p}
Input Noise Current	i_n	$f = 10Hz$		0.01		pA/\sqrt{Hz}
Unity Gain Bandwidth	GBW			2.0		MHz
Slew Rate	SR	$C_L = 50pF$, $R_L = 10k\Omega$		2.5		V/ μs
Rise Time	t_r			0.2		μs
Overshoot				20		%
Operating Supply Range	V^+ to V^-		4.5		16	V
Supply Current	I_{SUPP}	no load		1.2	2.0	mA
Internal Chopping Frequency	f_{CLKOUT}	pins 13 and 14 open (DIP)	120	200	375	Hz
Clamp ON Current (Note 2)		$R_L = 100k\Omega$	25	70	200	μA
Clamp OFF Current (Note 2)		$-4.0V \leq V_{OUT} \leq +4.0V$		1		pA
Offset Voltage vs Time				100		nV/ \sqrt{month}

NOTE 1: Operating temperature range for M series parts is $-55^\circ C$ to $+125^\circ C$, for I series is $-20^\circ C$ to $+85^\circ C$, for C series is $0^\circ C$ to $+70^\circ C$.

NOTE 2: See OUTPUT CLAMP under detailed description.

NOTE 3: OUTPUT CLAMP not connected. See typical characteristic curves for output swing vs clamp current characteristics.

NOTE 4: Limiting input current to $100\mu A$ is recommended to avoid latch-up problems. Typically 1mA is safe, however this is not guaranteed.

NOTE 5: $I_{OS} \approx 2 \times I_{BIAS}$

NOTE 6: All pins are designed to withstand electrostatic discharge (ESD) levels in excess of 2000V (Mil Std 883B Method 3015.1 Test Circuit)

NOTE 7: Sample tested. Limits are not used to calculate outgoing quality level.

ICL7650/7650B

Chopper Stabilized Operational Amplifier

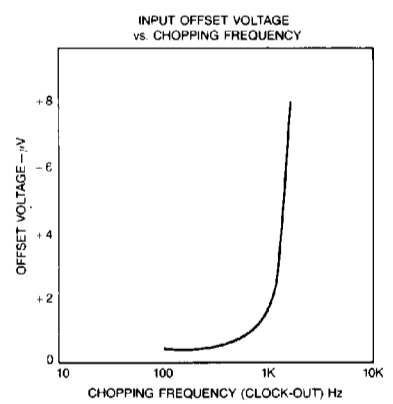
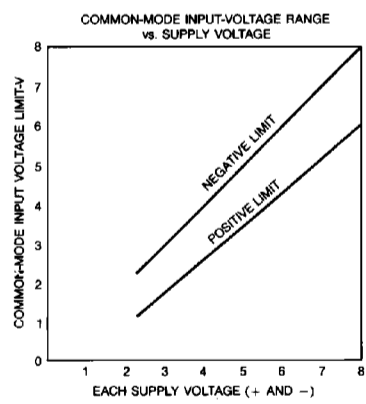
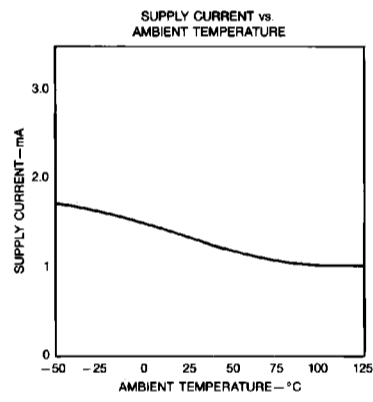
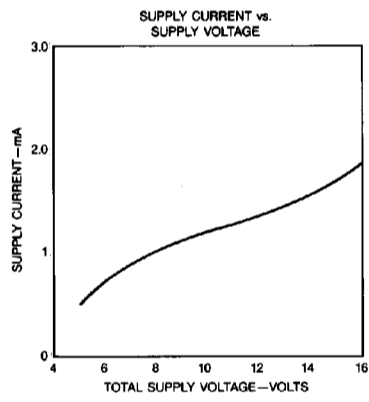
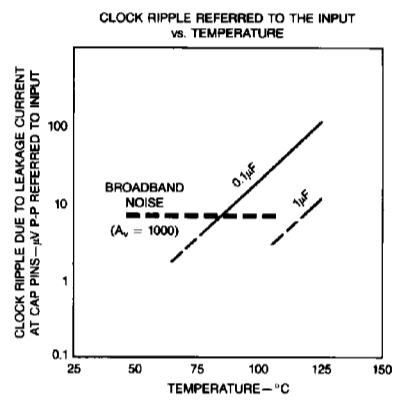
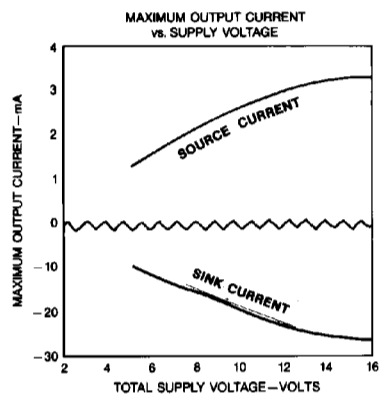

Chopper Stabilized Operational Amplifier

MAX9270/7650B

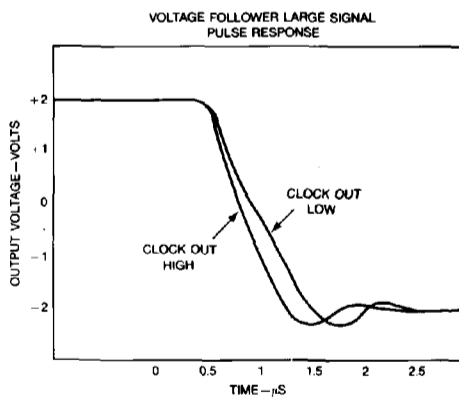
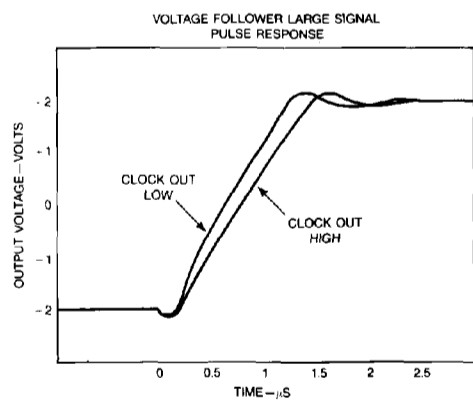
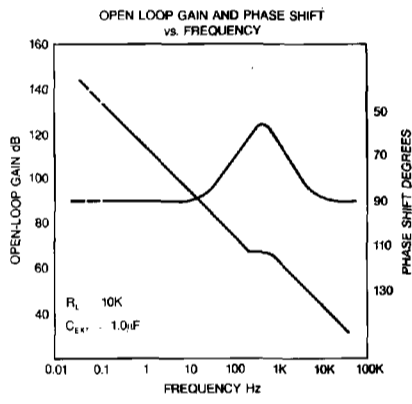
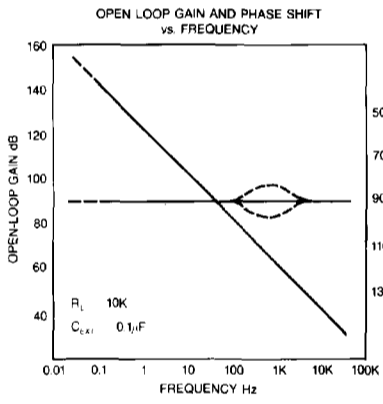
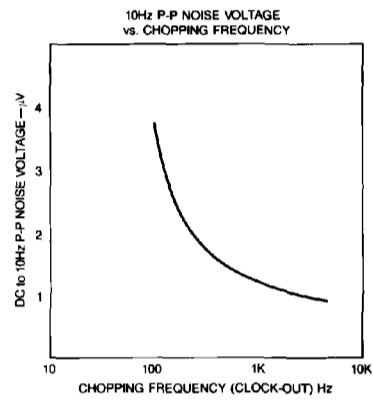
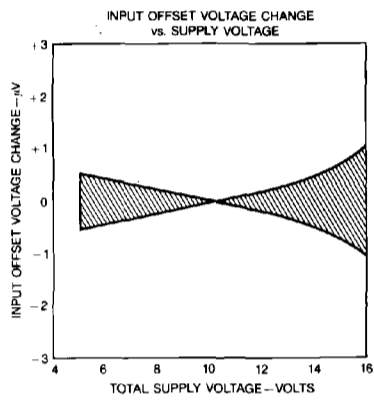

Chopper Stabilized Operational Amplifier

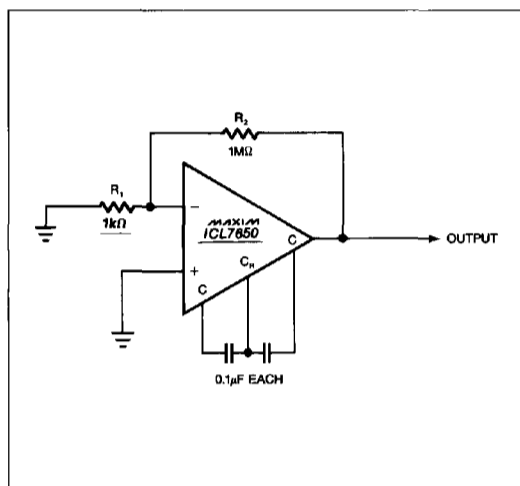

Figure 1. Maxim ICL7650 Test Circuit

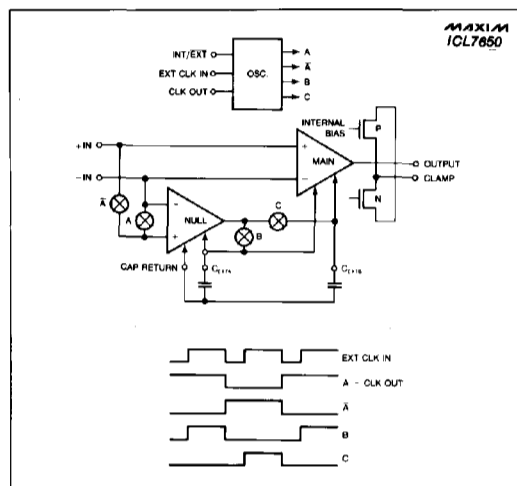

Figure 2. Block Diagram

Detailed Description

Amplifier

Figure 2 shows the major elements of the ICL7650. Two amplifiers are illustrated, the main amplifier and the nulling amplifier, both have offset-null capability. The main amplifier is connected full-time from the input to the output. The nulling amplifier, under the control of the chopping frequency oscillator and clock circuit, alternately nulls itself and the main amplifier. The nulling arrangement, which is independent of the output level, operates over the full power supply and common mode ranges. This device exhibits an exceptionally high CMRR, PSRR and A_{VOL} . The nulling connections, which are MOSFET back gates, have inherently high impedance. The two external capacitors provide the required storage of the nulling potentials and the necessary nulling-loop time constants.

The chopper frequency charge injection at the input terminals is minimized by careful balance of the input switches. The feed forward-type injection into the compensation capacitor is also minimized. This is the main cause of spikes at the output in this type of circuit.

Output Clamp

The clamp reduces overload recovery time inherent with chopper-stabilized amplifiers. When tied to the summing junction, or inverting input pin, a current path between this point and the output occurs just before the output device saturates. This prevents uncontrolled input differential and the consequent charge build-up on the correction-storage capacitors. There is only a slight reduction in the output swing.

Intermodulation

Intermodulation effects have been a problem with older chopper stabilized amplifier modules. Intermodulation occurs since the amplifier has a finite AC gain, and therefore will have a small AC signal at the input. In a chopper stabilized module this small AC signal is detected, chopped, and fed into the offset correction circuit. This results in spurious outputs at the sum and difference frequencies of the chopping frequency and the input signal frequency. Other intermodulation effects in chopper stabilized modules include gain and phase anomalies near the chopping frequency.

These effects are substantially reduced in the ICL7650 by adding into the nulling circuit a dynamic current that compensates for the AC on the inputs due to the amplifiers finite gain. Unlike the modules, the ICL7650 can precisely compensate for the finite AC gain since both the AC gain rolloff and the intermodulation compensation current are controlled by matched capacitors onboard the ICL7650.

Nulling Capacitor Connection

Separate pins are provided for C_{RETN} and CLAMP in the 14 lead version of the ICL7650. With the 8 lead version, a choice must be made. If the clamp feature is not used, the "-1" version with the C_{RETN} pin should be ordered since it will give slightly lower noise and improved AC CMRR. If the clamp feature is used, order the standard ICL7650 and connect the external capacitors to V^- . To prevent load current IR drops and other extraneous signals from being injected into the capacitors, a separate printed circuit board trace should be used to connect the capacitor commons directly to the V^- pin. The outside foil of the capacitors should be connected to the low impedance side of the null storage circuit, V^- or C_{RETN} . This will act as an electro-static voltage shield.

Chopper Stabilized Operational Amplifier

ICL7650/7650B

Clock Operation

A frequency of 200Hz is generated by the internal oscillator of the ICL7650. This is available at the CLK OUT pin on the 14-pin devices. The use of an external clock is also optional on these parts. The INT/EXT pin may be left open for normal operation due to the internal pull-up. However, the internal clock must be disabled and this pin must be tied to V^- if an external clock is desired. An external clock signal may then be applied to the EXT CLK IN pin. The duty cycle of the external clock is not critical at low frequencies. However, a 50% to 80% positive duty cycle is preferred for frequencies above 500 Hz, since the capacitors are charged only when EXT CLK IN is HIGH. This ensures that any transients have time to settle before the capacitors are turned OFF. The external clock should swing between GROUND and (V^+) for power supplies up to ± 6 volts, and between (V^+) and ($V^+ - 6V$) for higher supply voltages.

To avoid a capacitor imbalance during overload, a strobe signal may be used. Neither capacitor will be charged if a strobe signal is connected to EXT CLK IN so that it is low during the time that the overload signal is applied to the amplifier. A typical amplifier will drift less than $10 \mu V/s$ since the leakage of the capacitor pins is quite low at room temperature. Relatively long measurements may be made with little change in offset.

Applications

Device Selection

In many applications Maxim's interchangeable ICL 7652 is preferred over the ICL 7650. The ICL7650 has a higher gain-bandwidth product and lower input bias currents, while the ICL7652 has less noise. The major change in the ICL7652 to reduce the noise is an increase in the size of the input FETs. This, however, increases the leakage at the ICL7652's external null pins. This means the ICL7650 can operate to a higher temperature with $0.1 \mu F$ capacitors before the clock ripple (due to leakage at the null capacitor pins) becomes excessive and $1.0 \mu F$ external capacitors are required.

Output Stage/Load Driving

The ICL7650 is in some ways like a transconductance amplifier whose open loop gain is proportional to load resistance. This behavior is apparent when loads are less than the high impedance stage (approximately $18K\Omega$ for 1 output circuit). The open loop gain, for example, will be 17dB lower with a $1K\Omega$ load than with a $10K\Omega$ load. This lower gain is of little consequence if the amplifier is used strictly for DC, since the DC gain is typically greater than 120 dB even with a $1K\Omega$ load. For wideband applications, however, the best frequency response will be achieved with a load resistor of $10k\Omega$ or higher. The result will be a smooth 6dB/octave response from 0.1Hz to 2MHz, with phase shifts of less than 10° in the transition region where the main amplifier takes over from the null amplifier.

Component Selection

C_{EXTA} and C_{EXTB} , the two required capacitors, have optimum values depending on the clock or chopping frequency. The correct value is $0.1 \mu F$ for the preset internal clock. This component value should be scaled proportionally to the relationship between the chopping frequency and the nulling time constant if an external clock is used. A low leakage ceramic capacitor may prove suitable for many applications, however, a high-quality film-type capacitor such as mylar is preferred. Low dielectric absorption capacitors (such as polypropylene) should be used for lowest settling on initial turn-on. With low dielectric absorption capacitors, the ICL7650 will settle to $1 \mu V$ offset in 100 ms, but several seconds may be required if ceramic capacitors are used.

Thermo-electric Effects

Thermo-electric effects developed in thermocouple junctions of dissimilar metals, alloys, silicon, etc., ultimately limit precision DC measurements. Unless all junctions are at the same temperature, thermoelectric voltages typically around $10 \mu V/^\circ C$, but up to hundreds of $\mu V/^\circ C$ for some materials, will be generated. In order to realize the extremely low offset voltages that the chopper amplifier can provide it is essential to take special precautions to avoid temperature gradients. To eliminate air movement, all components should be enclosed (particularly those caused by power dissipating elements in the system). Power supply voltages and power dissipation should be kept to a minimum, and low thermo-electric coefficient connections should be used where possible. Separation from surrounding heat dissipating elements is advised, and high impedance loads are preferable.

Chopper Stabilized Operational Amplifier

Input Guarding

Low leakage, high impedance, CMOS inputs allow the ICL7650 to make measurements of high impedance sources. Stray leakage paths can decrease input resistance and increase input currents unless inputs are guarded. Boards must be thoroughly cleaned with TCE or alcohol and blown dry with compressed air. The board should be coated with epoxy or silicone after cleaning to prevent contamination.

Leakage currents may cause trouble even with properly cleaned and coated boards, particularly since the input pins are adjacent to pins that are at supply potentials. A significant reduction in leakage can be accomplished by using guarding to lower the voltage difference between inputs and adjacent

metal runs. By using a 10-lead pin circle, with the leads of the device formed so that the holes adjacent to the inputs are empty when it is inserted in the board, input guarding of the 8-lead TO-99 package is accomplished. A conductive ring surrounding the inputs, the guard, is connected to a low-impedance point that is approximately the same voltage as the inputs. The guard then absorbs the leakage current from the high voltage pins. Typical guard connections are shown in Figure 3.

The 14-pin dip configuration has been specifically designed to ease input guarding. The pins adjacent to the inputs are not used.

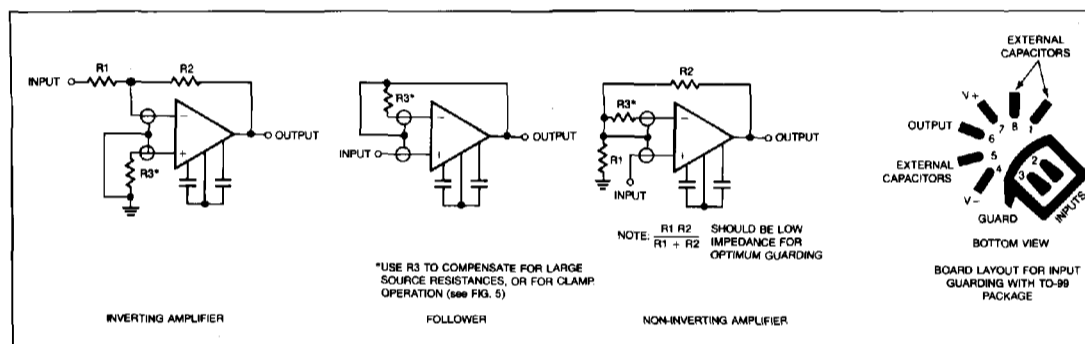

Figure 3. Input Guard Connection

Pin Compatibility

The 8-lead pin-out of the ICL7650 generally corresponds to that of the industry standard 8-pin devices, LM741, LM101, etc. However, the external null storage capacitors are connected to pins 1 and 8, whereas on most operational amplifiers these are left open or used for offset null or compensation capacitors.

The OP-05 and OP-07 operational amplifiers can be converted for ICL7650 operation. This can be accomplished by replacing the offset-null pot between pins 1 and 8, and V^+ by two capacitors from these pins to V^- . For LM 108 devices, the compensation capacitor is replaced by the external nulling capacitors. Pin 5 is the output clamp connection on the ICL7650. By removing any circuit connections from this pin, the LM101/748/709 devices can undergo a similar conversion.

Typical Applications

Figure 4 shows the ICL7650 automatically nulling the offset voltage of a high speed amplifier. The ICL7650 continuously monitors the voltage at the inverting input of the high speed amplifier, integrates the error, and drives the high speed amplifier's non-inverting input to correct for the offset voltage detected at the inverting input. The DC offset characteristics of the circuit are determined by the ICL7650, while the AC

performance is determined by the high speed amplifier. While this circuit continuously and automatically adjusts the offset of the high speed amplifier to less than $5\mu V$, it does not correct for errors caused by the input bias current, and R_f should be as low as is practical. This technique can be used with any operational amplifier that is configured as an inverting amplifier.

Figures 5 and 6 illustrate basic inverting and non-inverting amplifier circuits. An output clamping circuit is used in both circuits to enhance the overload recovery performance. The supply voltage ($\pm 8V$ max) and the output drive capability ($10K\Omega$ load for full swing) are the only limitations on the replacement of other operational amplifiers by the ICL7650. By using a simple booster circuit, these limitations may be overcome (Figure 7). This enables the full output capabilities of the LM118 (or any other standard device) to be combined with the input capabilities of the ICL7650. The loop gain stability should be watched carefully when the feedback network is added, particularly when a slower amplifier such as the 741 is used.

A lower voltage supply is required when mixing the ICL7650 with circuits that operate at $\pm 15V$ supplies. One approach is to use a highly-efficient voltage divider. This is illustrated in Figure 8 where the ICL7660 voltage converter is used to convert $+15V$ to $7.5V$.

Chopper Stabilized Operational Amplifier

ICL7650/7650B

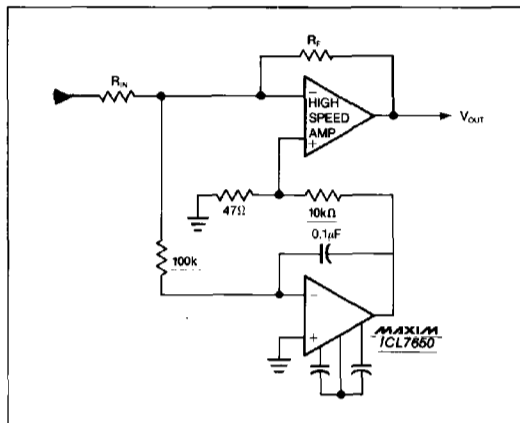

Figure 4. Nulling a High Speed Amplifier

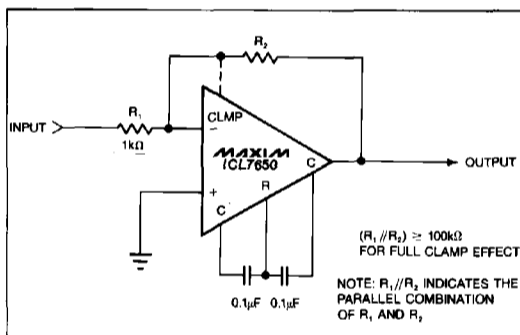

Figure 5. Inverting Amplifier with Optional Clamp

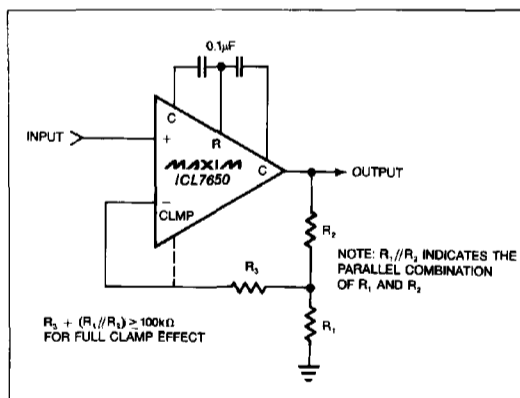

Figure 6. Non-Inverting Amplifier with Optional Clamp

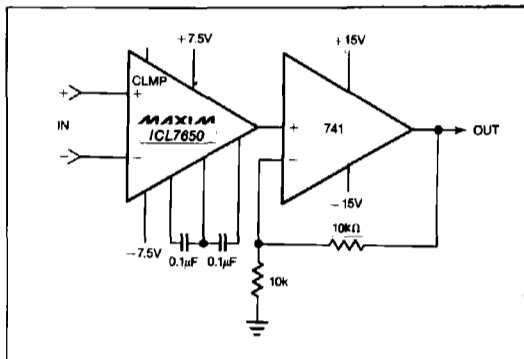

Figure 7. Using 741 to boost Output Drive Capability

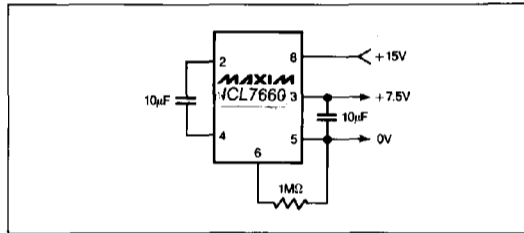
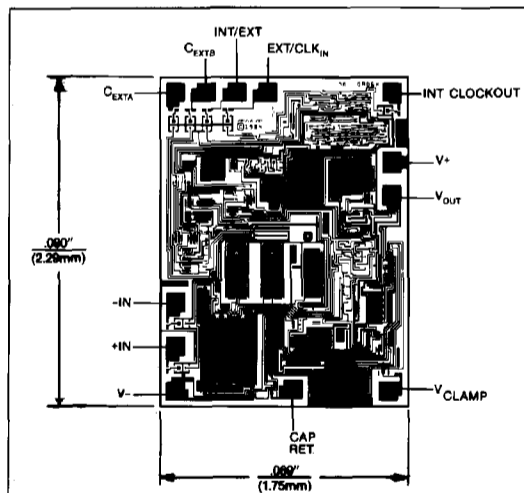

Figure 8. Splitting +15V with ICL7660. Same for -15V (95% Efficiency).

Chip Topography



Chopper Stabilized Operational Amplifier

ICL7650/7650B

Package Information

**Plastic DIP
PLASTIC
DUAL-IN-LINE
PACKAGE
(0.300 in.)**

DIM	INCHES		MILLIMETERS	
	MIN	MAX	MIN	MAX
A	—	0.200	—	5.08
A1	0.015	—	0.38	—
A2	0.125	0.175	3.18	4.45
A3	0.055	0.080	1.40	2.03
B	0.016	0.022	0.41	0.56
B1	0.045	0.065	1.14	1.65
C	0.008	0.012	0.20	0.30
D1	0.005	0.080	0.13	2.03
E	0.300	0.325	7.62	8.26
E1	0.240	0.310	6.10	7.87
e	0.100	—	2.54	—
eA	0.300	—	7.62	—
eB	—	0.400	—	10.16
L	0.115	0.150	2.92	3.81

PKG.	DIM	PINS	INCHES		MILLIMETERS	
			MIN	MAX	MIN	MAX
P	D	8	0.348	0.390	8.84	9.91
P	D	14	0.735	0.765	18.67	19.43
P	D	16	0.745	0.765	18.92	19.43
P	D	18	0.885	0.915	22.48	23.24
P	D	20	1.015	1.045	25.78	26.54
N	D	24	1.14	1.265	28.96	32.13

21-0043A

**Narrow SO
SMALL-OUTLINE
PACKAGE
(0.150 in.)**

DIM	INCHES		MILLIMETERS	
	MIN	MAX	MIN	MAX
A	0.053	0.069	1.35	1.75
A1	0.004	0.010	0.10	0.25
B	0.014	0.019	0.35	0.49
C	0.007	0.010	0.19	0.25
E	0.150	0.157	3.80	4.00
e	0.050	—	1.27	—
H	0.228	0.244	5.80	6.20
L	0.016	0.050	0.40	1.27

DIM	PINS	INCHES		MILLIMETERS	
		MIN	MAX	MIN	MAX
D	8	0.189	0.197	4.80	5.00
D	14	0.337	0.344	8.55	8.75
D	16	0.386	0.394	9.80	10.00

21-0041A

Chopper Stabilized Operational Amplifier

Package Information (continued)

ICL7650/7650B

**CERDIP
CERAMIC DUAL-IN-LINE
PACKAGE
(0.300 in.)**

DIM	INCHES		MILLIMETERS	
	MIN	MAX	MIN	MAX
A	—	0.200	—	5.08
B	0.014	0.023	0.36	0.58
B1	0.038	0.065	0.97	1.65
C	0.008	0.015	0.20	0.38
E	0.220	0.310	5.59	7.87
E1	0.290	0.320	7.37	8.13
e	0.100		2.54	
L	0.125	0.200	3.18	5.08
L1	0.150	—	3.81	—
Q	0.015	0.070	0.38	1.78
S	—	0.098	—	2.49
S1	0.005	—	0.13	—

DIM	PINS	INCHES		MILLIMETERS	
		MIN	MAX	MIN	MAX
D	8	—	0.405	—	10.29
D	14	—	0.785	—	19.94
D	16	—	0.840	—	21.34
D	18	—	0.960	—	24.38
D	20	—	1.060	—	26.92
D	24	—	1.280	—	32.51

21-0045A

**8-PIN
TO-99 METAL CAN
PACKAGE**

DIM	INCHES		MILLIMETERS	
	MIN	MAX	MIN	MAX
A	0.165	0.185	4.19	4.70
phi_b	0.016	0.019	0.41	0.48
phi_b1	0.016	0.021	0.41	0.53
phi_D	0.335	0.375	8.51	9.40
phi_D1	0.305	0.335	7.75	8.51
phi_D2	0.110	0.160	2.79	4.06
e	0.200 BSC		5.08 BSC	
e1	0.100 BSC		2.54 BSC	
F	—	0.040	—	1.02
k	0.027	0.034	0.69	0.86
k1	0.027	0.045	0.69	1.14
L	0.500	0.750	12.70	19.05
L1	—	0.050	—	1.27
L2	0.250	—	6.35	—
Q	0.010	0.045	0.25	1.14
alpha	45° BSC		45° BSC	
beta	45° BSC		45° BSC	

21-0022A