

QuickSaver® Charge Controller for Nickel-Cadmium and Nickel-Metal Hydride Batteries

General Description

The ICS1700A is a CMOS device designed for the intelligent charge control of either nickel-cadmium (NiCd) or nickel-metal hydride (NiMH) batteries. The controller uses a pulsed-current charging technique together with voltage slope termination. The ICS1700A employs a four stage charge sequence that provides a complete recharge without overcharging. The controller has four user-selectable charge rates available for customized charging systems. The ICS1700A is a pin-for-pin replacement for the original ICS1700 controller.

The ICS1700A monitors for the presence of a battery and begins charging if a battery is installed within the first 10 seconds after a reset. Voltage and temperature are measured to ensure a battery is within fast charge conditions before charge is initiated.

Applications

Battery charging systems for:

- Portable consumer electronics
- Power tools
- Audio/video equipment
- Communications equipment

Features

- Multiple charge termination methods include:
 - Voltage slope
 - Maximum temperature
 - Charge timer
- Four stage charge sequence:
 - Soft start charge
 - Fast charge
 - Topping charge
 - Maintenance charge
- Reverse-pulse charging available in all charge stages
- Four programmable charge rates between 15 minutes (4C) and two hours (C/2)
- Out-of-temperature range detection
 - Hot battery: charger shutdown
 - Cold battery: low current charge
- Ten second polling mode for battery detection
- Battery fault with shutdown protection

Block Diagram

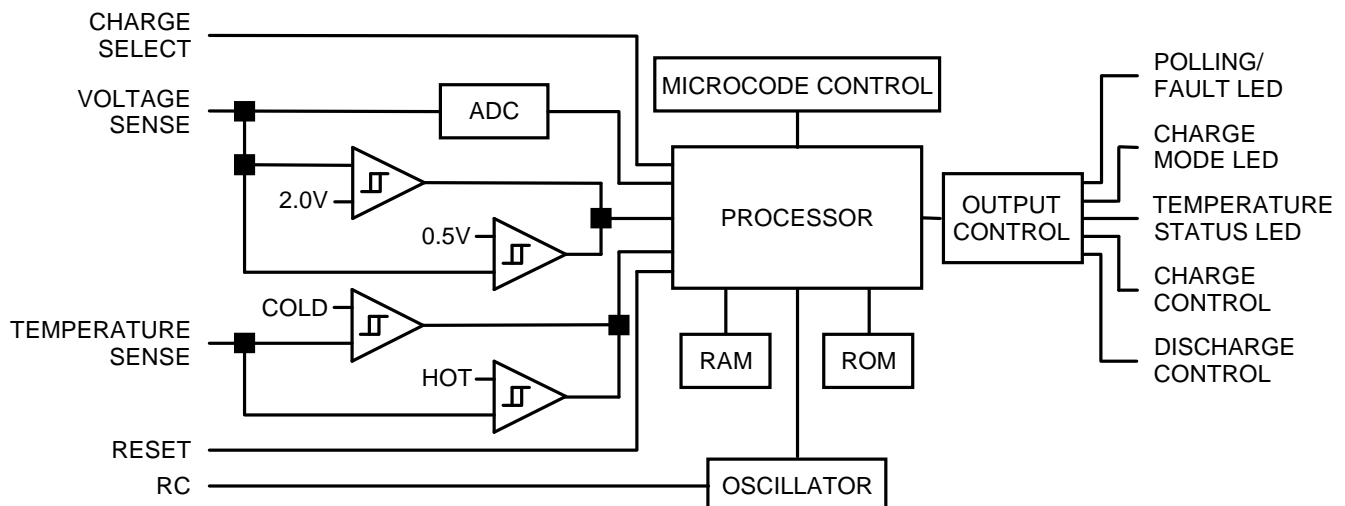



ICS1700A

Pin Configuration

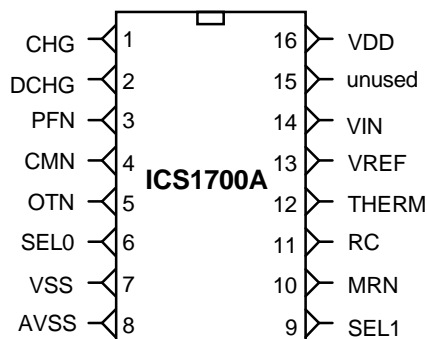

16-Pin DIP

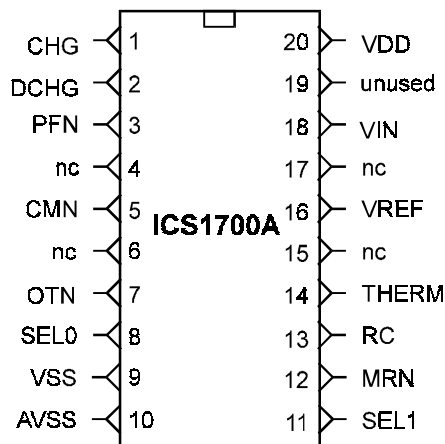

20-Pin SOIC

Pin Definitions

Pin Number		Pin Name	Type	Definition
DIP	SOIC			
1	1	CHG	OUT	Active high TTL compatible signal used to turn on an external current source to provide current to charge the battery.
2	2	DCHG	OUT	Active high TTL compatible signal available to turn on a discharge circuit.
3	3	PFN	OUT	Polling fault indicator. An active low turns on an external indicator to show the controller is either polling for the presence of the battery or has determined the battery has been removed.
4	5	CMN	OUT	Charge mode indicator. A continuous low shows the controller is in a soft start or fast charge. The indicator flashes during the topping and maintenance charges.
5	7	OTN	OUT	Out-of-temperature range indicator. An active low turns on an external indicator showing the battery is out of the normal fast charge temperature range.
6	8	SEL0	IN	Input used with the SEL1 pin to program the device for the desired charge rate.
7	9	VSS		Ground.
8	10	AVSS		Ground.
9	11	SEL1	IN	Input used with the SEL0 pin to program the device for the desired charge rate.
10	12	MRN	IN	Master reset signal. A logic low pulse greater than 700 ms initiates a device reset.
11	13	RC	IN	An external resistor and capacitor sets the frequency of the internal clock.
12	14	THERM	IN	Thermistor or thermal switch input for temperature sensing.
13	16	VREF		1.26V voltage reference.
14	18	VIN	IN	Battery voltage normalized to one cell with an external resistor divider.
15	19	unused		Ground.
16	20	VDD		Device supply =+5.0 VDC

Note: (DIP/SOIC)
 Pin 6/8 has an internal pull-up.
 Pin 9/11 has an internal pull-up.
 Pin 10/12 has an internal pull-up.
 Pin 12/14 has an internal pull-up.
 Pins 4, 6, 15, and 17 are unconnected in the SOIC package.



Controller Operation

Charging Stages

The charging sequence consists of four stages. The application of current is shown graphically in Figure 1. The soft start stage gradually increases current levels up to the user selected fast charge rate during the first two minutes. The soft start stage is followed by the fast charge stage, which continues until termination. After termination, a two hour C/10 topping charge is applied. The topping charge is followed by a C/40 maintenance charge.

Soft Start Charge

Some batteries may exhibit an unusual high impedance condition while accepting the initial charging current, as shown in Figure 2. Unless dealt with, this high impedance condition can cause a voltage peak at the beginning of the charge cycle that would be misinterpreted as a fully charged battery by the voltage termination methods.

The soft start charge eases batteries into the fast charge stage by gradually increasing the current to the selected fast charge rate. The gradual increase in current alleviates the voltage peak. During this stage, only positive current pulses are applied to the battery. The duty cycle of the applied current is increased to the selected fast charge rate, as shown in Figure 3, by extending the current pulse on every cycle until the pulse is about one second in duration. The initial current pulse is approximately 200ms. The CMN indicator is activated continuously during this stage

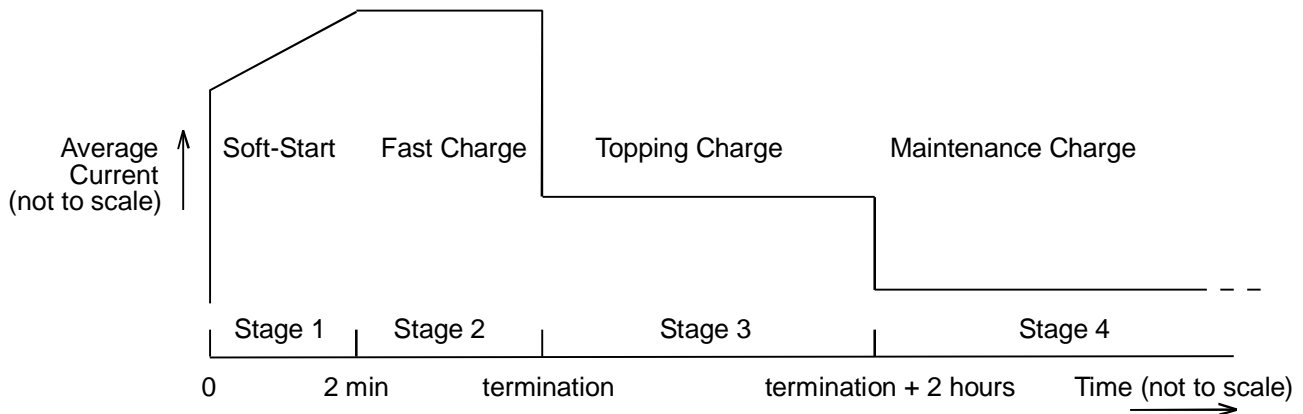

Figure 1: Graphical representation of average current levels during the four charging stages

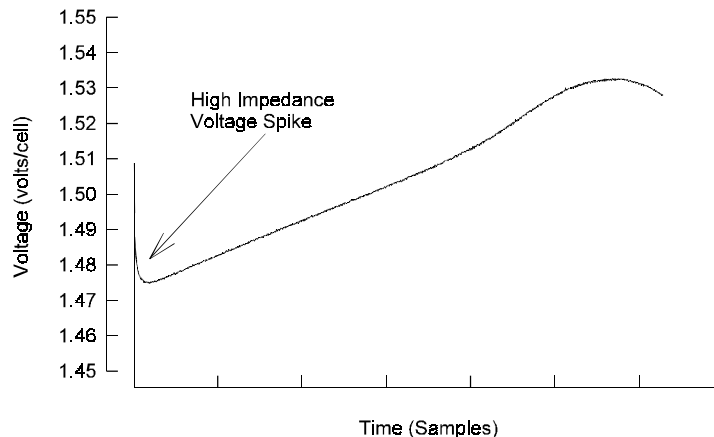

Figure 2: High impedance voltage spike at the beginning of charge

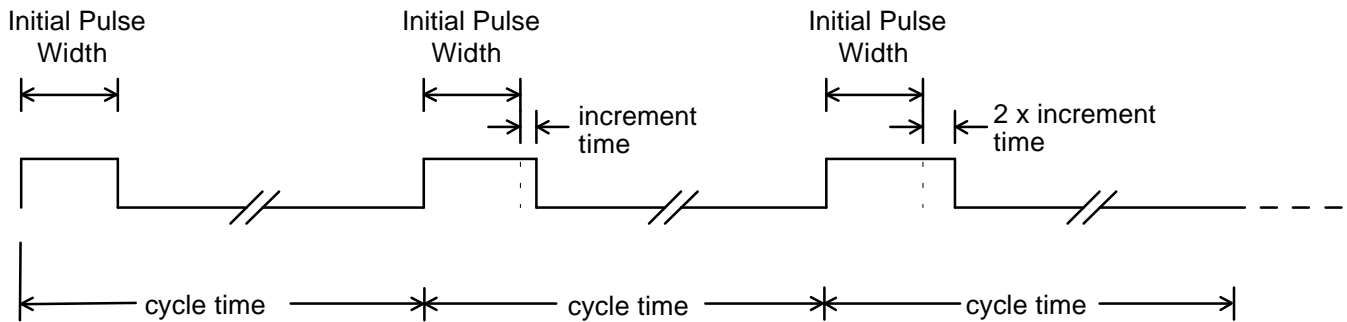

Figure 3: Cycle-to-cycle increase of the soft-start current pulse widths

Fast Charge

In the second stage, the **ICS1700A** applies the charging current in a series of charge and discharge pulses. The technique consists of a positive current charging pulse followed by a high current, short duration discharge pulse. The cycle, shown with charge, discharge, rest and data acquisition periods in Figure 4, repeats every second until the batteries are fully charged.

The amplitude of the current pulse is determined by system parameters such as the current capability of the charging system, the desired charge rate, the cell capacity and the ability of that cell to accept the charge current. The **ICS1700A** can be set for four user-selectable fast charge rates from 15 minutes (4C) to two hours (C/2). Charge pulses occur approximately every second. The CMN indicator is activated continuously during this stage.

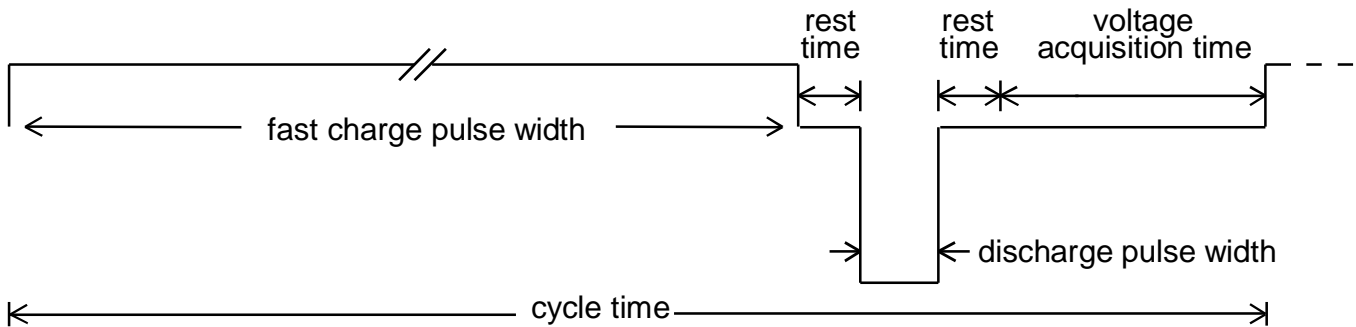

Figure 4: Charge cycle showing charge and discharge current pulses



The discharge current pulse amplitude is typically set to about 2.5 times the amplitude of the charging current based on 1.4V/cell. For example, if the charge current is 4 amps, then the discharge current is set at about 10 amps. The energy removed during the discharge pulse is a fixed ratio to the positive charge rate. The amplitude of the discharge pulse does not affect the operation of the part as described in this section.

A voltage acquisition window immediately follows a brief rest time after the discharge pulse. No charge is applied during the rest time or during the acquisition window to allow the cell chemistry to settle. Since no current is flowing, the measured cell voltage is not obscured by any internal or external IR drops or distortions caused by excess plate surface charge. The **ICS1700A** makes one continuous reading of the no-load battery voltage during the entire acquisition window. The voltage that is measured during this window contains less noise and is a more accurate representation of the true state of charge of the battery.

Topping Charge

The third stage is a topping charge that applies current at a rate low enough to prevent cell heating but high enough to ensure a full charge.

The topping charge applies a C/10 charging current for two hours. The current consists of the same pulse technique used during the fast charge stage; however, the duty cycle of the pulse sequence has been extended as shown in Figure 5. Extending the time between charge pulses allows the same charging current used in the fast charge stage so that no changes to the current source are necessary. For example, the same charge pulse that occurs every second at a 2C fast charge rate will occur every 20 seconds for a topping charge rate of C/10. The CMN indicator flashes at a one second rate during this stage.

Maintenance Charge

The maintenance charge is intended to offset the natural self-discharge of NiCd or NiMH batteries by keeping the cells primed at peak charge. After the topping charge ends, the **ICS1700A** begins this charge stage by extending the duty cycle of the applied current pulses to a C/40 rate. The maintenance charge will last for as long as the battery voltage is greater than 0.5V at the VIN pin. The CMN indicator flashes at a one second rate during this stage.

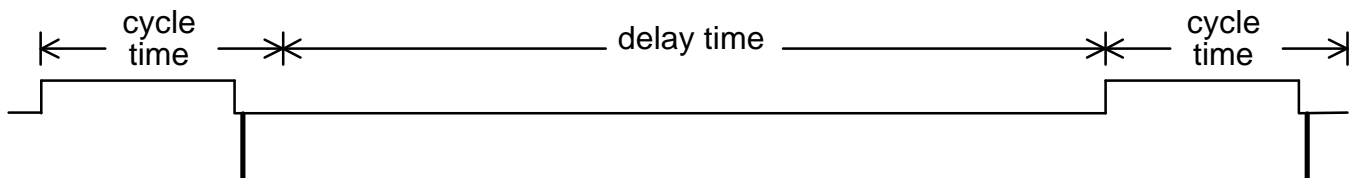

Figure 5: Representative timing diagram for topping and maintenance charge



Charge Termination Methods

Several charge termination schemes, including voltage slope, maximum temperature and a fast charge timer are available. The voltage slope method may be used with or without the maximum temperature method. Maximum temperature and the fast charge timer are available as backup methods.

Voltage Slope Termination

The most distinctive point on the voltage curve of a charging battery in response to a constant current is the voltage peak that occurs as the cell approaches full charge. By mathematically calculating the first derivative of the voltage, a second curve can be generated showing the change in voltage with respect to time as shown in Figure 6. The slope will reach a maximum just before the actual peak in the cell voltage. Using the voltage slope data, the ICS1700A calculates the point of full charge and accurately terminates the applied current as the battery reaches that point. The actual termination point depends on the charging characteristics of the particular battery.

Cells that are not thoroughly conditioned or possess an unusual cell construction may not have a normal voltage profile. The ICS1700A uses an alternate method of charge termination based on a slight decrease in the voltage slope to stop charge to cells whose voltage profile is very shallow. This method looks for a flattening of the voltage slope which may indicate a shallow peak in the voltage profile. The zero slope point occurs slightly beyond the peak voltage and is shown on the voltage curve graph.

Maximum Temperature Termination

Maximum temperature can be sensed using either a NTC thermistor or a thermal switch. Maximum temperature termination can also be bypassed if desired, although it is strongly recommended that some form of temperature termination be used.

If an NTC thermistor is used, an internal voltage threshold determines when the battery is too hot to charge. As temperature increases, the voltage across the thermistor will drop. This voltage is continually compared to the internal voltage threshold. If the thermistor voltage drops below the internal threshold, the OTN indicator is activated and the controller shuts down. The controller must be reset once the hot battery fault condition has cleared to restart the charge sequence.

If a thermal switch is used, a 45°C open circuit switch is recommended. When the thermal switch opens, an internal pull-up at the THERM pin results in a logic high which shuts down the controller and activates the OTN indicator. The controller must be reset once the hot battery fault condition has cleared to restart the charge sequence.

Maximum temperature termination can be disabled by grounding the THERM pin. See the section on *Temperature Sensing* for more information.

Fast Charge Timer Termination

The controller uses a timer to limit the fast charge duration. These times are pre-programmed, and are automatically adjusted in time duration according to the charge rate selected. Fast charge timer termination is best suited as a safety backup feature to limit the duration of the fast charge stage. The fast charge timer is always enabled and cannot be disabled. See Table 2 for more information.

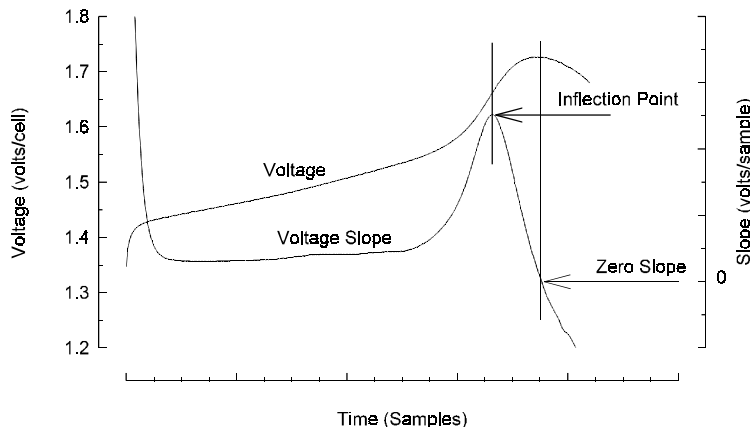

Figure 6: Voltage and slope curves showing inflection and zero slope points



Battery Polling

Upon power-up or after a reset is issued, any excess charge from filter capacitors at the charging system terminals is removed with a series of discharge pulses. After the discharge pulse series is complete, the voltage at VIN must be greater than 0.5V when a battery is present. If the voltage at VIN is less than 0.5V, the **ICS1700A** assumes no battery is attached and initiates a polling sequence.

The **ICS1700A** then applies a 100ms charge pulse. During the pulse, the **ICS1700A** monitors the VIN pin to determine if the divided down terminal voltage is greater than the internal 2.0V reference. If the battery is present, the voltage is clamped below the 2.0V reference when the current pulse is applied and the fast charge stage begins immediately. If a battery is not present, the voltage at VIN rises above the 2.0V reference and the PFN fault indicator is activated.

The charge pulses repeat for 10 seconds. If the battery is installed within 10 seconds, the **ICS1700A** will turn off the PFN fault indicator and enter the soft start stage. If the battery is not installed within 10 seconds, the PFN fault indicator remains active and the **ICS1700A** shuts down. A reset must be issued to restart the controller after installing the battery.

Battery Fault Detection

The **ICS1700A** will turn on the PFN fault indicator and shut down if the battery is removed or if an open circuit occurs in the current path anytime after fast charge has been initiated. When in the topping charge or maintenance charge stages, a charge pulse may not occur for several seconds. During the period between charge pulses, the voltage at VIN should be greater than 0.5V if a battery is attached. If the voltage at VIN is less than 0.5V, the **ICS1700A** assumes the battery has been removed, a fault condition is indicated by the PFN fault indicator, and the controller shuts down.

Cold Battery Charging

Cold battery charging is activated if a voltage at the THERM pin is in the cold battery voltage range, as shown in Figure 7. The **ICS1700A** checks for a cold battery before initiating fast charge. If a cold battery is present before fast charging begins, the **ICS1700A** begins a two hour C/10 topping charge (the pulsed duty cycle is based on the selected charge rate). If the battery is still cold after the two hour topping charge is complete, the **ICS1700A** begins a C/40 maintenance charge. The maintenance charge will continue for as long as the battery remains cold. The thermistor voltage at the THERM pin is checked every second to see if the battery has warmed up. If so, the **ICS1700A** stops the topping charge or maintenance charge and begins a fast charge at a rate selected by the SEL0 and SEL1 inputs. See the section on *Temperature Sensing* for more information.

The CMN will flash at a one second rate, and the OTN indicator will be active, indicating that a low current charge is being applied to a battery that is outside the specified temperature range for fast charging.

ICS1700A



Pin Descriptions

The **ICS1700A** requires some external components to control the clock rate, sense temperature and provide an indicator display. The controller must be interfaced to an external power source that will provide the current required to charge a battery pack and, if desired, a circuit that will sink discharge current.

Output Logic Signals: CHG, DCHG Pins

The CHG and DCHG pins are active high, TTL compatible outputs. In addition to being TTL compatible, the CMOS outputs are capable of sourcing current which adds flexibility when interfacing to other circuitry. A logic high on the CHG pin indicates that the charging current supply should be activated. If applicable, a logic high on the DCHG pin indicates that the discharge circuit should be activated.

Care must be taken to control wiring resistance and inductance. The load resistor must be capable of handling this short duration high-amplitude pulse.

Indicators: CMN, PFN, OTN Pins

The controller has three outputs for driving external indicators. These pins are active low. The three indicator outputs have open drains and are designed to be used with LEDs. Each output can sink over 20mA which requires the use of an external current limiting resistor. The three indicator signals denote fast charge stage, topping and maintenance stages, and the polling detect or battery fault and out-of-temperature range modes as shown in Table 1.

The charge mode (CMN) indicator is activated continuously during the soft start and fast charge stages. The CMN indicator flashes at a one second rate when the **ICS1700A** is applying a topping or maintenance charge.

The polling fault (PFN) indicator is on when the **ICS1700A** polls for a battery for the first 10 seconds. The controller applies periodic charge pulses to detect the presence of a battery. The indicator is a warning that these charge pulses are appearing at the charging system terminals at regular intervals. When a battery is detected, the indicator is turned off. The indicator is also active if the battery is removed from the system, warning that a fault has occurred.

The out-of-temperature range (OTN) indicator is active whenever the voltage at the temperature sense (THERM) input enters a range that indicates that the attached battery is too hot to charge. The OTN indicator is also activated with the CMN indicator if the controller is initialized with the battery in the cold battery charge region.

Table 1: Indicator Description List

PFN	CMN	OTN	Description
on			Polling mode or battery fault
	flash		Maintenance and topping charge
	on		Fast charge
		on	Hot battery shutdown
	flash	on	Cold battery charge
	on	on	see Applications Information
on	one flash		see Applications Information



Charge Rate Selection: SEL0, SEL1 Pins

The SEL0 and SEL1 inputs must be programmed by the user to inform the **ICS1700A** of the desired charge rate. When a low level is required, the pin must be grounded. When a high level is required, no connection is required since each pin has an internal 75k Ω pull-up to V_{DD}. The voltage ranges for low (L) and high (H) are listed in Table 6, *DC Characteristics*. To program the SEL0 and SEL1 inputs, refer to the *Charge Rate List* in Table 2.

The **ICS1700A** does not control the current flowing into the battery in any way other than turning it on and off. The required current for the selected charge rate must be provided by the user's power source. The external charging circuitry should provide current at the selected charge rate. For example, to charge a 1.2 ampere hour battery in 30 minutes (2C), approximately 2.4 amperes of current is required.

Table 2: Charge Rate List

SEL0	SEL1	Charge Rate	Topping Charge Pulse Rate	Maintenance Charge Pulse Rate	Fast Charge Timer Duration (after reset)
L	L	4C (15 min)	one every 40 sec	one every 160 sec	30 min
L	H	2C (30 min)	one every 20 sec	one every 80 sec	60 min
H	L	1C (60 min)	one every 10 sec	one every 40 sec	90 min
H	H	C/2 (120 min)	one every 5 sec	one every 20 sec	210 min

See the section on *Controller Operation* for additional information on the topping charge and maintenance charge. See the section on *Charge Termination Methods* for additional information on the charge timer.



Master Reset: MRN Pin

The MRN pin is provided to re-program the controller for a new charging sequence. This pin has an internal pull-up of about 75kΩ. A logic low on the MRN pin must be present for more than 700ms for a reset to occur. As long as the pin is low, the controller is held in a reset condition. A master reset is required to change charge rates or clear a temperature fault condition. Upon power-up, the controller automatically resets itself.

Clock Input: RC Pin

The RC pin is used to set the frequency of the internal clock when an external 1 MHz clock is not available. An external resistor must be connected between this pin and VDD. An external capacitor must be connected between this pin and ground. The frequency of the internal clock will be about 1 MHz with a 16kΩ resistor and a 100pF capacitor. All time durations noted in this document are based on a 1 MHz clock. Operating the clock at a lower frequency will proportionally change all time durations. Operating the clock at a frequency significantly lower than 1 MHz, without adjusting the charge current accordingly, will lessen the effectiveness of the fast charge timer and lower the accuracy of the controller. Operating the clock at a frequency greater than 1 MHz will also change all time durations and, without adjusting the charge current accordingly, may cause termination to occur due to the fast charge timer expiring rather than by the battery reaching full charge.

The clock may be driven by a 1 MHz external 0 to 5V pulse provided the duty cycle is between 10% and 60%. The clock input impedance is about 1kΩ.

Temperature Sensing: THERM Pin

The THERM pin is provided for hot and cold battery detection and for maximum temperature termination of fast charge when used in conjunction with an NTC thermistor. The THERM pin also provides for hot battery and maximum temperature termination when used in conjunction with a normally closed thermal switch. Several internal voltage thresholds are used by the controller depending on whether a thermistor or a thermal switch is used. Figure 7 shows the internal thresholds overlaid on a typical thermistor curve.

- Using an NTC thermistor for hot and cold battery detection:

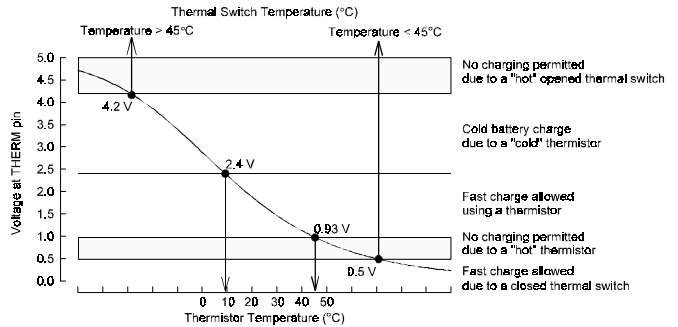

Figure 7: Voltage levels for temperature sensing with a thermistor or thermal switch

The THERM pin requires some thought if a thermistor is going to be used for hot and cold battery detection. The example below works for a typical 10kΩ @ 25°C NTC thermistor. Consider using the controller to prevent charging above 45°C and reducing the current below 10°C. At 10°C the resistance of the thermistor is 18kΩ. At 45°C, the resistance drops to 4.7kΩ. The ICS1700A has an internal voltage threshold at 10°C at 2.4V, and an internal voltage at 45°C at 0.93V as shown in Figure 7. At 25°C the voltage at the THERM pin is set at the midpoint of the thresholds:

$$0.93V + \frac{2.40V - 0.93V}{2} = 1.67V.$$

The THERM pin has a 75kΩ internal pull-up (R_{pu}). Using a resistor divider with 10kΩ for the thermistor (R_{th}) and an external fixed resistor (R_{fix}), the divider looks like Figure 8 at 25°C:

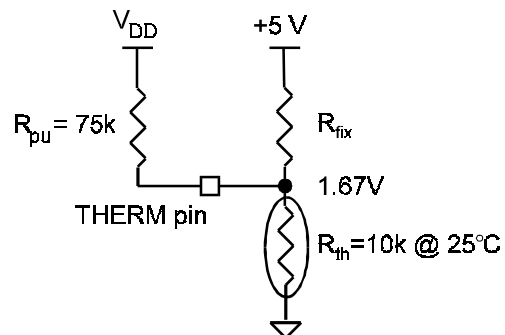

Figure 8: Voltage divider at the THERM pin at 25°C



To set the voltage at the THERM pin for 1.67V at 25°C, the equivalent divider looks like Figure 9.

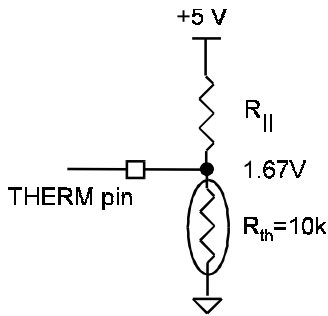

Figure 9: Equivalent voltage divider

The parallel resistance $R_{||}$ is calculated:

$$R_{||} = \frac{5.0V - 1.67V}{1.67V/10k\Omega} = 20k\Omega.$$

The internal pull-up resistance R_{pu} and the parallel resistance $R_{||}$ are known so the external fixed resistor can be calculated from:

$$R_{fix} = \frac{R_{pu}R_{||}}{R_{pu} - R_{||}}$$

Substituting in known values: $R_{fix} = 27.27k\Omega$. A $27k\Omega$ standard value is used for R_{fix} .

Since the thermistor resistance R_{th} is specified by manufacturers at a particular temperature, the voltage across the thermistor V_{th} at that temperature can be calculated from:

$$V_{th} = \frac{R_{th}}{R_{||} + R_{th}} (5V),$$

with the drop across the resistor divider equal to 5V. For this example, the calculated voltage with $R_{th}=18k\Omega$ at $10^\circ C$ is 2.37V and with $R_{th}=4.7k\Omega$ at $45^\circ C$ the voltage is 0.95V. Table 3 lists the internal thresholds for hot and cold battery detection. If the voltage across the thermistor (at the THERM pin) drops below 0.93V, the **ICS1700A** will shut down due to a hot battery fault condition and will not restart unless reset. If the voltage dropped across the thermistor is above 2.4V before fast charge is initiated, the **ICS1700A** will begin a reduced current charge. See the *Cold Battery Charging* section for more information.

Table 3: Thermistor Voltage Thresholds

Parameter	Voltage	Battery Temperature
Cold Battery Thermistor Voltage	>2.4	<10°C
Hot Battery Thermistor Voltage	<0.93	>45°C

- Using a thermal switch for hot battery detection:

A thermal switch that opens at about $45^\circ C$ is recommended. The thermal switch must be connected between the THERM pin and ground. When the thermal switch is closed, the voltage at the THERM pin must be below 0.5V for normal operation. When the thermal switch opens (see Figure 10), the internal pull-up at the THERM pin will raise the voltage above 4.2V and the **ICS1700A** will shut down and will not restart unless reset. Table 4 contains the internal voltage thresholds used with a thermal switch.

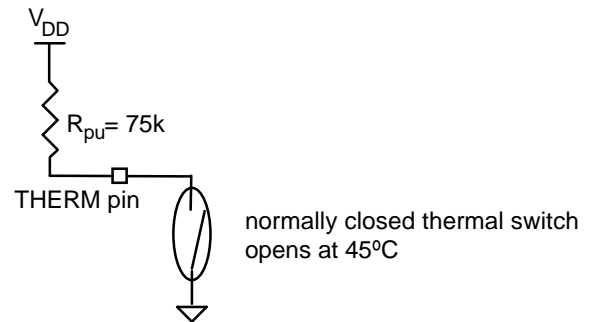

Figure 10: Thermal switch to connection to ground at the THERM pin

Table 4: Thermal Switch Voltage Thresholds

Parameter	Voltage	Battery Temperature
Opened Thermal Switch Voltage	>4.2	>45°C
Closed Thermal Switch Voltage	<0.5	<45°C



ICS1700A

- Using no temperature sensor:

If a temperature sensor is not used, the THERM pin must be grounded.

Voltage Input: VIN Pin

The battery voltage must be normalized by an external resistor divider network to one cell. The electrochemical potential of one cell is about 1.2V. For example, if the battery consists of six cells in series, the voltage at the VIN pin must be equal to the total battery voltage divided by six. This can be accomplished with two resistors, as shown in Figure 11. To determine the correct resistor values, count the number of cells to be charged in series. Then choose either R1 or R2 and solve for the other resistor using:

$$R1 = R2 \times (\# \text{ of cells} - 1) \text{ or } R2 = \frac{R1}{(\# \text{ of cells} - 1)}$$

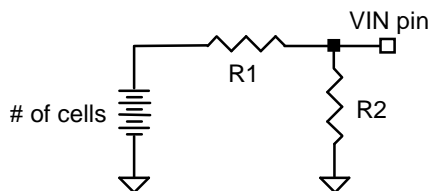

Figure 11: Resistor divider network at the VIN pin

Voltage Reference: VREF Pin

A 1.26V reference is present at this pin. The reference sets internal voltage references such as the 0.5V and 2.0V internal thresholds used by the controller for battery polling/fault detection and the analog/digital converter range.

The reference provides a fast way of checking the internal thresholds. Measuring VREF with a high input impedance volt meter ($>1M\Omega$) is required. The reference can only be used if it is buffered with a high impedance device having an input impedance greater than $1M\Omega$. Buffering is essential to ensure that the internal voltage thresholds and analog/digital converter range and resolution are not altered.

The reference may be overridden by an external 1.2V to 1.3V reference.

Power: VDD Pin

The power supply for the device must be connected to the VDD pin. The voltage should be +5 VDC and should be supplied to the part through a regulator that has good noise rejection and an adequate current rating. The controller requires up to a maximum of 11mA with $V_{DD}=5.00V$.

Grounding: VSS, AVSS Pins

There are two ground pins. Both pins must be connected together at the device. This point must have a direct connection to a solid ground plane.



Data Tables

Table 5: Absolute Maximum Ratings

Supply Voltage	6.5	V
Logic Input Levels	-0.5 to $V_{DD} + 0.5$	V
Ambient Operating Temperature	0 to 70	°C
Storage Temperature	-55 to 150	°C

Stresses above those listed under Absolute Maximum Ratings may cause permanent damage to the device. This is a stress rating only. Functional operation of the device at the Absolute Maximum Ratings or other conditions not consistent with the characteristics shown in this document is not recommended. Exposure to absolute maximum rating conditions for extended periods may affect product reliability.

Table 6: DC Characteristics

PARAMETER	SYMBOL	TEST CONDITIONS	MIN	TYP	MAX	UNITS
Supply Voltage	V_{DD}		4.5	5.0	5.5	V
Supply Current	I_{DD}			7.3		mA
High Level Input Voltage SEL0, SEL1	V_{IH}		3.6	4.1	4.5	V
Low Level Input Voltage SEL0, SEL1	V_{IL}		0.73	0.75	0.8	V
Low Level Input Current, pull-up THERM, MRN	I_{IL}	$V=0.4V$		74		μA
High Level Source Current CHG, DCHG	I_{OH}	$V=V_{DD}-0.4V$		28		mA
Low Level Sink Current CHG, DCHG	I_{OL}	$V=0.4V$		25		mA
Low Level Sink Current, indicator PFN, CMN	I_{OL}	$V=0.4V$		40		mA
Low Level Sink Current, indicator OTN	I_{OL}	$V=0.4V$		28		mA
Input Impedance				1.0		$M\Omega$
Analogue/Digital Converter Range			0-2.2	0-2.7	0-2.7	V
Voltage Reference	V_{REF}		1.20	1.26	1.31	V

Table 7: DC Voltage Thresholds

$T_{AMB}=25^{\circ}C$

PARAMETER	TYP	UNITS
Minimum Battery Voltage	0.5	V
Maximum Battery Voltage	2.0	V
Thermistor - Cold Temperature	2.4	V
Thermistor - Hot Temperature	0.93	V
Thermal Switch - Open	4.2	V
Thermal Switch - Closed	0.5	V



Table 8: Timing Characteristics

$R \approx 16k\Omega$, $C \approx 100pF$

PARAMETER	SYMBOL	REFERENCE	TYP	UNITS
Clock Frequency			1.0	MHz
Reset Pulse Duration	t_{RESET}	see Figure B	700	ms
Charge Pulse Width	t_{CHG}	see Figure A	1048	ms
Discharge Pulse Width	t_{DCHG}	see Figure A	5.0	ms
Rest Time	t_R	see Figure A	4.0	ms
Data Acquisition Time	t_{DA}	see Figure A	16.4	ms
Cycle Time	t_{CYCLE}	see Figure A	1077	ms
Capacitor Discharge Pulse Width			5.0	ms
Capacitor Discharge Pulse Period			100	ms
Polling Detect Pulse Width			100	ms
Polling Detect Pulse Period			624	ms
Soft Start Initial Pulse Width			200	ms
Soft Start Incremental Pulse Width			7.0	ms
RESET to SEL Dynamic Reprogram Period	t_{RSA}	see Figure B	1160	ms

Timing Diagrams

Figure A:

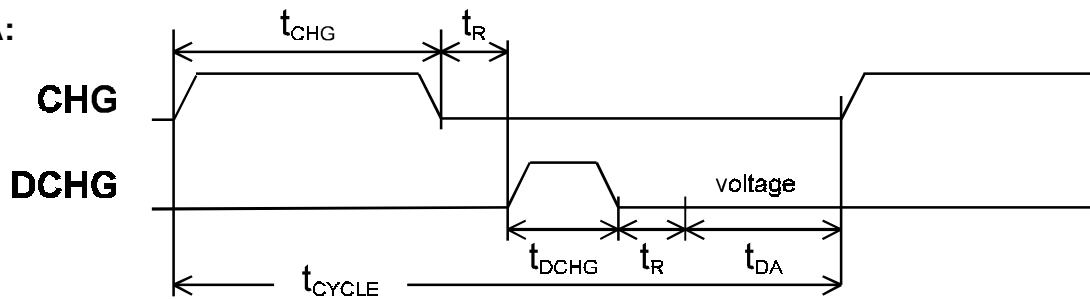
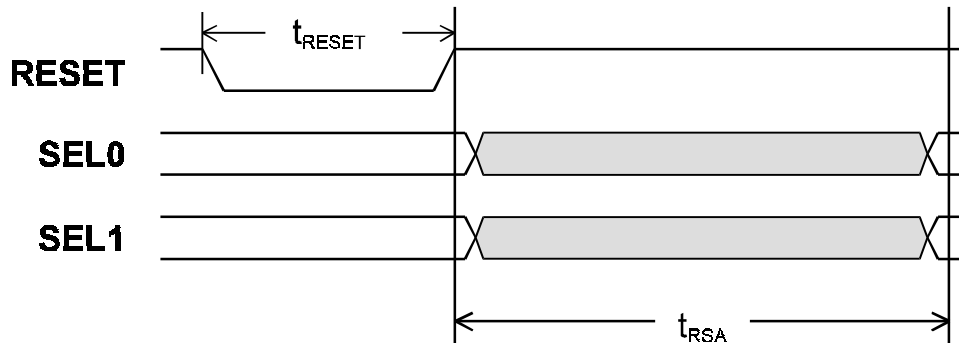

Figure B:





Applications Information

To ensure proper operation of the **ICS1700A**, external components must be properly selected. The external current source used must meet several important criteria to ensure optimal performance of the charging system.

VIN Divider Resistors

Figure 12 shows a typical application using the **ICS1700A**. R1 and R2 must be carefully selected to ensure that battery detection and voltage termination methods operate properly. R1 and R2 are selected to scale the battery voltage down to the voltage of one cell. The following table shows some typical values. Additional information is available in the *Voltage Input* section.

Cells	R1	R2
1	Short	Open
2	2.0k	2.0k
3	2.0k	1.0k
4	3.0k	1.0k
5	12k	3.0k
6	10k	2.0k
7	12k	2.0k
8	9.1k	1.3k

PC Board Design Considerations

It is very important that care be taken to minimize noise coupling and ground bounce. In addition, wires and connectors can add significant resistance and inductance to the charge and discharge circuits.

When designing the printed circuit board, make sure ground and power traces are wide and bypass capacitors are used right at the controller. Use separate grounds for the signal, charge and discharge circuits. Separate ground planes on the component side of the PC board are recommended. Be sure to connect these grounds together at the negative lead of the battery only. For the discharge circuit, keep the physical separation between power and return (ground) to a minimum to minimize field radiation effects. This precaution is also applicable to the constant current source, particularly if it is a switch mode type. Keep the **ICS1700A** and the constant current source control circuits outside the power and return loop described above. These precautions will prevent high circulating currents and coupled noise from disturbing normal operation.

Voltage Slope Termination

In general, the voltage slope termination method works best for equipment where the battery is fast charged with the equipment off or the battery is removed from the equipment for fast charge. The voltage slope termination method works best with a constant current flow into the battery during fast charge. If equipment draws a known constant current while the battery is charging, this current should be added to the fast charge current. Equipment that randomly or periodically requires current from the battery during fast charge needs evaluation to ensure it does not interfere with the proper operation of the voltage slope termination method.

Charging sources that produce decreasing current as fast charge progresses may cause a voltage inflection that may result in termination before full charge. For example, if the charge current is supplied through a resistor or if the charging source is a constant current type that has insufficient input voltage, the current will decrease and may cause a termination before full charge. Other current source characteristics that can cause a voltage inflection that is characteristic of a fully charged battery are inadequate ripple and noise attenuation capability or charge current decreasing due to thermal drift. Charging sources that have any of the above characteristics need evaluation to access their suitability for the application.

The controller soft start stage, built-in noise filtering, and fast charge timer operate optimally when the constant current source charges the battery at the rate selected. If the actual charge current is significantly less than the rate selected, the conditioning effect of the soft start stage and the controller noise immunity are lessened. Also, the fast charge timer may cause termination based on time duration rather than by the battery reaching full charge due to inadequate charge current.



ICS1700A

Maximum Temperature Termination

Maximum temperature termination is best suited as a safety back-up feature. Maximum temperature termination requires that the thermal sensor be in intimate contact with the battery. A low thermal impedance contact area is required for accurate temperature sensing. The area and quality of the contact surface between the sensor and the battery directly affects the accuracy of temperature sensing. Thermally conductive adhesives may have to be considered in some applications to ensure good thermal transfer from the battery case to the sensor.

The thermal sensor should be placed on the largest surface of the battery for the best accuracy. The size of the battery is also a consideration when using temperature termination. The larger the battery, lower the surface area to volume ratio. Because of this, larger batteries are less capable in dissipating internal heat.

Additional considerations beyond the basics mentioned above may be involved when using maximum temperature termination where sudden changes in ambient temperature occur or where forced air cooling is used. For these applications, the surface area of the thermal sensor in contact with the battery compared to the surface area of the thermal sensor in contact with the ambient air may be significant. For example, bead type thermistors are relatively small devices which have far less thermal capacity compared to most batteries. Insulating the surface of the thermistor that is in contact with the ambient air should help minimize heat loss by the thermistor and maintain accuracy.

Charging System Status by Indicator

The *Indicator Description List* in Table 1 contains displays that are caused by charging system abnormalities. At power-up or after a reset is issued, one flash of the CMN indicator followed by a continuous PFN indication results from a voltage present at the battery terminals with the current source off and no battery. Check the current source and ensure that it produces no more than the equivalent of 350mV/cell when turned off with no battery. If the VIN divider resistors were not properly selected, an open circuit voltage that is actually less than the equivalent of 350mV/cell with the charger off and no battery will not divide down this open circuit voltage properly and produce a PFN fault indication. Check the VIN divider and ensure that it properly normalizes the battery voltage to the electrochemical potential of about 1.2V cell. If the PFN fault indicator is active immediately after power-up or after a reset is issued with the battery installed, then the constant current source is producing more than the equivalent of 350mV/cell when off and there is an open connection between the charger terminals and the battery. Check wires, connections, battery terminals, and the battery itself for an open circuit condition.

If the CMN and OTN indicators are active together, this is an indication that the battery temperature has dropped to below 10°C after a fast charge was initiated with the battery temperature normal. If this condition is observed and the battery temperature did not drop after fast charge was initiated, check the thermistor circuit mechanically for poor contact and electrically for excessive noise.

Enhanced Performance Characteristics

The **ICS1700A** is an enhanced performance, pin-for-pin replacement for the original ICS1700. Improved internal features provide additional capabilities. The charge sequence, voltage slope termination method, and analog-to-digital converter resolution allow the **ICS1700A** to charge either NiMH or NiCd batteries. The **ICS1700A** accepts either a thermal switch or thermistor input for temperature sensing. The polling mode for battery detection responds quickly to the removal of the battery throughout the charge sequence. The reset input debounce eliminates sensitivity to field effects and ground bounce when the PC board design recommendations cited in this document are employed. The temperature sense input debounce eliminates sensitivity to shock and vibration associated with the use of a thermal switch.



ICS1700A

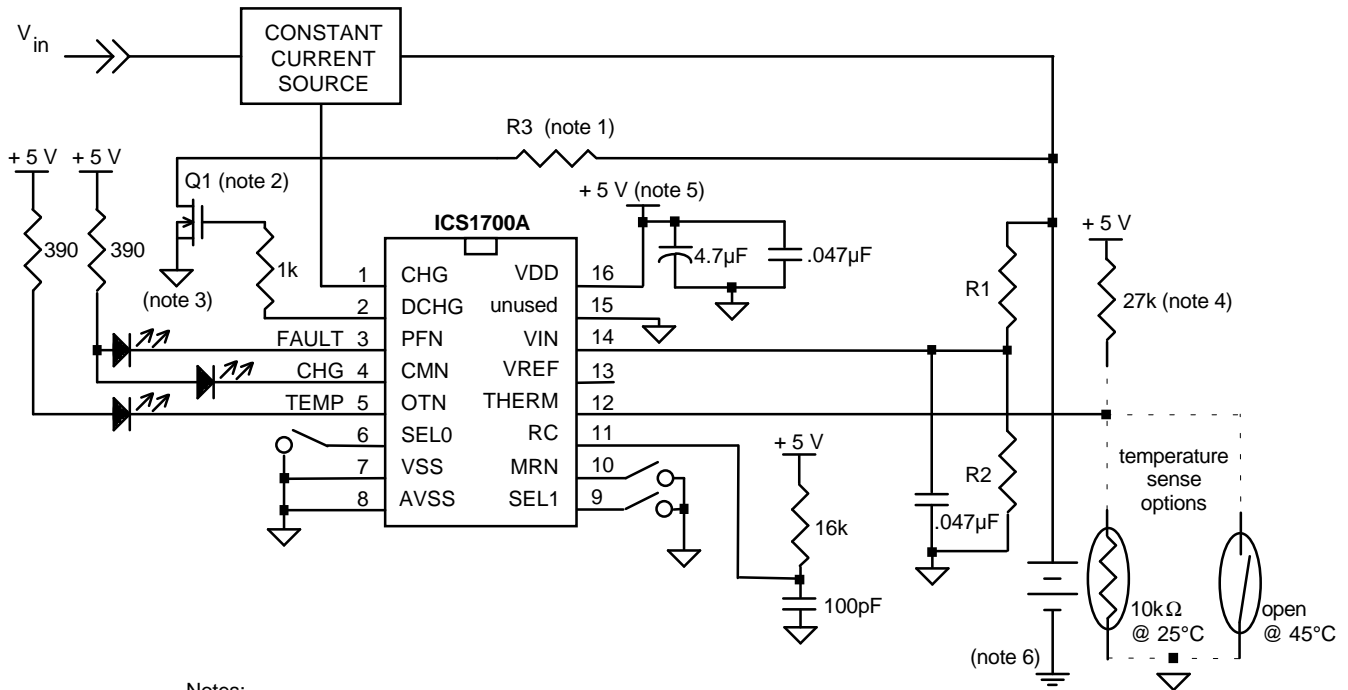

Notes:

- 1) Value of R3 determined by discharge current and capacity of battery pack.
- 2) Discharge FET is logic-level compatible in this application.
- 3) DC return of discharge FET must be connected close to negative battery terminal.
- 4) Resistor is needed only if a thermistor is used. Value may change depending on thermistor.
- 5) Regulated supply
- 6) Power ground; others are signal ground. Connect signal ground to power ground at negative battery terminal only.

Figure 12: Functional Diagram



ICS1700A

Package Information

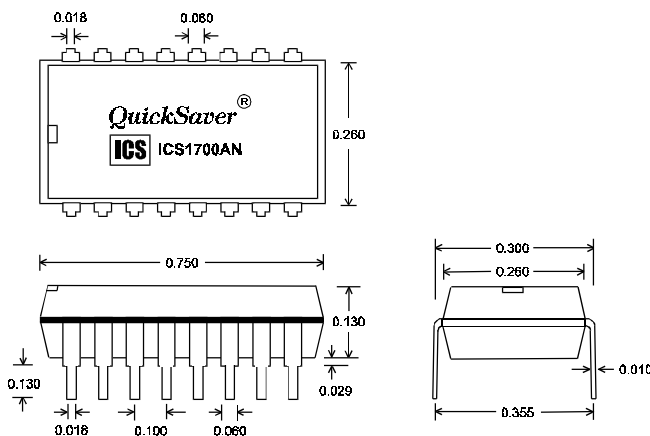

All package dimensions are in inches.

16-Pin DIP Package

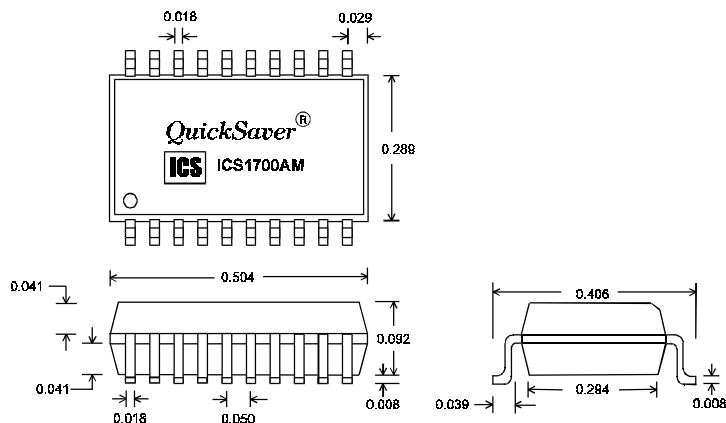

All package dimensions are in inches.

20-Pin SOIC Package

Ordering Information

ICS1700AN, ICS1700AM, or ICS1700AMT

Example:

ICS XXXXA M

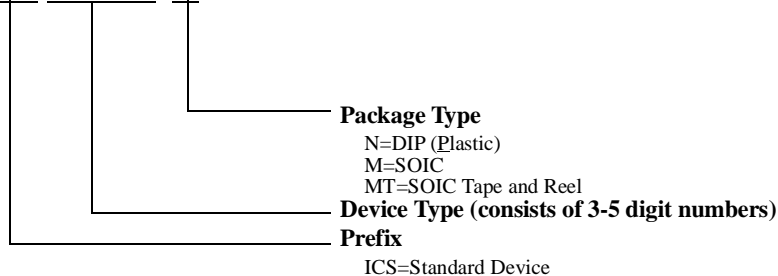



IMPORTANT NOTICE

Integrated Circuit Systems, Inc. makes no claim about the capability of any particular battery (NiCd or NiMH) to accept a fast charge. ICS strongly recommends that the battery manufacturer be consulted before fast charging. ICS shall be held harmless for any misapplication of this device such as: exceeding the rated specifications of the battery manufacturer; charging batteries other than nickel-cadmium or nickel-metal hydride type; personal or product damage caused by the charging device, circuit, or system itself; unsafe use, application, and/or manufacture of a charging system using this device.

ICS reserves the right to make changes in the device data identified in this publication without further notice. ICS advises its customers to obtain the latest version of all device data to verify that any information being relied upon by the customer is current and accurate.

ICS does not assume any liability arising out of or associated with the application or use of any product or integrated circuit or component described herein. ICS does not convey any license under its patent rights or the patent rights of others described herein. In the absence of a written or prior stated agreement to the contrary, the terms and conditions stated on the back of the ICS order acknowledgment obtain.

ICS makes no warranty of any kind with regard to this material, including, but not limited to, the implied warranties of merchantability and fitness for a particular purpose.

ICS products are not designed, intended, or authorized for use as components in systems intended for surgical implant into the body, or other applications intended to support or sustain life, or for any nuclear facility application, or for any other application in which the failure of the ICS product(s) could create a situation where personal injury or death may occur. ICS will not knowingly sell its products for use in such applications, and the buyer shall indemnify and hold harmless ICS and its officers, employees, subsidiaries, affiliates, representatives and distributors against all claims, costs, damages, expenses, tort and attorney fees arising out of directly or indirectly, any claim of personal injury or death associated with such unintended or unauthorized use, even if such claim alleges that ICS was negligent regarding the design or manufacture of the part.

COPYRIGHT © 1994 Integrated Circuit Systems, Inc.