

**inmos**

# IMS1620M IMS1620LM CMOS

## High Performance 16K x 4 Static RAM MIL-STD-883C

### FEATURES

- INMOS' Very High Speed CMOS
- Advanced Process - 1.6 Micron Design Rules
- Full Military Temperature Operating Range (-55°C to + 125°C)
- MIL-STD-883C Processing
- 16K x 4 Bit Organization
- 45, 55 and 70 nsec Access Times
- Fully TTL Compatible
- Common Data Input & Output
- Three-state Output
- Power Down Function
- Single +5V ± 10% Operation
- 22-Pin, 300-mil DIP (JEDEC Std.)
- 22-Pin Ceramic LCC (JEDEC Std.)
- Battery Backup Operation - 2V Data Retention (L version only)

### DESCRIPTION

The INMOS IMS1620M is a high performance 16Kx4 CMOS Static RAM processed in full compliance to MIL-STD-883C and guaranteed to operate over the full military temperature range. The IMS1620M provides maximum density and speed enhancements with the additional CMOS benefits of lower power and superior reliability.

The IMS1620M features fully static operation requiring no external clocks or timing strobes, and equal address access and cycle times. Additionally, the IMS1620M provides a Chip Enable (/E) function that can be used to place the device into a low-power standby mode.

The IMS1620LM is a low power version offering battery backup data retention operating from a 2 volt supply.

The IMS1624M is the functional equivalent of the IMS1620M with an added Output Enable function.

### PIN CONFIGURATION



DIP

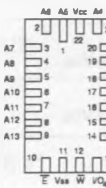

CHIP CARRIER

### LOGIC SYMBOL

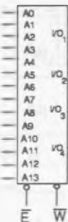

### BLOCK DIAGRAM

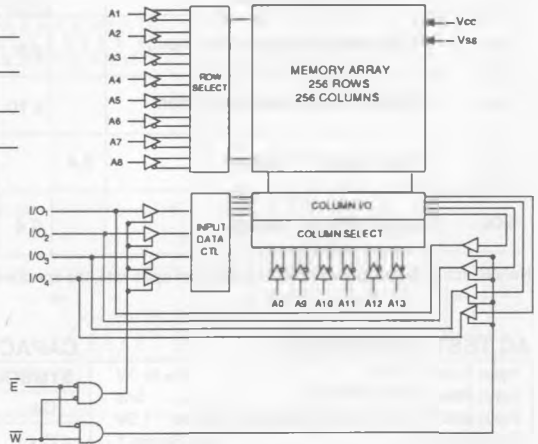

### PIN NAMES

A <sub>0</sub> - A <sub>13</sub> ADDRESS INPUTS		I/O DATA IN/OUT
W	WRITE ENABLE	V <sub>CC</sub> POWER
E	CHIP ENABLE	V <sub>SS</sub> GROUND

**ABSOLUTE MAXIMUM RATINGS\***

Voltage on any pin relative to V<sub>SS</sub>.....-2.0 to 7.0V  
 Voltage on I/O Pins (13-16).....-1.0 to (V<sub>CC</sub>+0.5)  
 Temperature Under Bias.....-55° C to 125° C  
 Storage Temperature .....-65° C to 150° C  
 Power Dissipation.....1W  
 DC Output Current.....25mA

\*Stresses greater than those listed under "Absolute Maximum Ratings" may cause permanent damage to the device. This is a stress rating only and functional operation of the device at these or any other conditions above those indicated in the operational sections of this specification is not implied. Exposure to absolute maximum rating conditions for extended periods may affect reliability.

(One output at a time, one second duration)

**DC OPERATING CONDITIONS**

SYMBOL	PARAMETER	MIN	TYP	MAX	UNITS	NOTES
V <sub>CC</sub>	Supply Voltage	4.5	5.0	5.5	V	
V <sub>SS</sub>	Supply Voltage	0	0	0	V	
V <sub>IH</sub>	Input Logic "1" Voltage	2.0		V <sub>CC</sub> +5	V	All inputs
V <sub>IL</sub>	Input Logic "0" Voltage	-1.0*		0.8	V	All inputs
T <sub>A</sub>	Ambient Operating Temperature	0	25	70	°C	400 linear ft/min air flow

\*V<sub>IL</sub> min = -3 volts for pulse width <20ns, note b.

**DC ELECTRICAL CHARACTERISTICS (-55° C < T<sub>A</sub> ≤ 125° C) (V<sub>CC</sub> = 5.0V ± 10%)<sup>a</sup>**

SYMBOL	PARAMETER	MIN	MAX	UNITS	NOTES
ICC1	Average V <sub>CC</sub> Power Supply Current		100	mA	t <sub>AVAV</sub> = t <sub>AVAV</sub> (min)
ICC2	V <sub>CC</sub> Power Supply Current (Standby, Stable TTL Input Levels)		30	mA	$\bar{E} \geq V_{IH}$ . All other inputs at V <sub>IN</sub> ≤ V <sub>IL</sub> or ≥ V <sub>IH</sub>
	IMS1620L version		20		
ICC3	V <sub>CC</sub> Power Supply Current (Standby, Stable CMOS Input Levels)		19	mA	$\bar{E} \geq (V_{CC} - 0.2)$ . All other inputs at V <sub>IN</sub> < 0.2 or ≥ (V <sub>CC</sub> - 0.2V)
	IMS1620L version		8		
ICC4	V <sub>CC</sub> Power Supply Current (Standby, Cycling CMOS Input Levels)		20	mA	$\bar{E} \geq (V_{CC} - 0.2)$ . Inputs cycling at V <sub>IN</sub> < 0.2 or ≥ (V <sub>CC</sub> - 0.2V)
	IMS1620L version		8		
IILK	Input Leakage Current (Any Input)		± 5	µA	V <sub>CC</sub> = max V <sub>IN</sub> = V <sub>SS</sub> to V <sub>CC</sub>
IOLK	Off State Output Leakage Current		± 10	µA	V <sub>CC</sub> = max V <sub>IN</sub> = V <sub>SS</sub> to V <sub>CC</sub>
VOH	Output Logic "1" Voltage	2.4		V	I <sub>OH</sub> = -4mA
VOL	Output Logic "0" Voltage		0.4	V	I <sub>OL</sub> = 8mA

Note a: I<sub>CC</sub> is dependent on output loading and cycle rate, the specified values are obtained with the output unloaded

**AC TEST CONDITIONS**

Input Pulse Levels ..... V<sub>SS</sub> to 3V  
 Input Rise and Fall Times ..... 5ns  
 Input and Output Timing Reference Levels.. 1.5V  
 Output Load ..... See Figure 1

**CAPACITANCE<sup>b</sup> (T<sub>A</sub>=25° C, f=1.0 MHz)**

SYMBOL	PARAMETER	MAX	UNITS	CONDITIONS
C <sub>IN</sub>	Input Capacitance	4	pF	ΔV = 0 to 3V
C <sub>OUT</sub>	Output Capacitance	7	pF	ΔV = 0 to 3V

Note b: This parameter is sampled and not 100% tested

**RECOMMENDED AC OPERATING CONDITIONS** ( $-55^{\circ}\text{C} \leq T_A \leq 125^{\circ}\text{C}$ ) ( $V_{CC} = 5.0\text{V} \pm 10\%$ )

## READ CYCLE<sup>9</sup>

NO.	SYMBOL		PARAMETER	IMS1620M-45		IMS1620M-55		IMS1620M-70		UNITS	NOTES
	Standard	Alternate		MIN	MAX	MIN	MAX	MIN	MAX		
1	t <sub>ELQV</sub>	t <sub>ACS</sub>	Chip Enable Access Time		45		55		70	ns	
2	t <sub>AVAV</sub>	t <sub>RC</sub>	Read Cycle Time	45		55		70		ns	c
3	t <sub>AVOV</sub>	t <sub>AA</sub>	Address Access Time		45		55		70	ns	d
4	t <sub>AXOX</sub>	t <sub>OH</sub>	Output Hold After Address Change	5		5		5		ns	
5	t <sub>ELOX</sub>	t <sub>LZ</sub>	Chip Enable to Output Active	5		5		5		ns	j
6	t <sub>EHQZ</sub>	t <sub>HZ</sub>	Chip Disable to Output Inactive	0	15	0	20	0	25	ns	f, j
7	t <sub>ELICCH</sub>	t <sub>PU</sub>	Chip Enable to Power Up	0		0		0		ns	j
8	t <sub>EHICCL</sub>	t <sub>PD</sub>	Chip Enable to Power Down		45		55		70	ns	j
		t <sub>r</sub>	Input Rise and Fall Times		50		50		50	ns	e, j

Note c: For READ CYCLE 1 & 2,  $\bar{W}$  is high for entire cycle.

Note d: Device is continuously selected;  $\bar{E}$  low.

Note e: Measured between  $V_{IL}$  max and  $V_{IH}$  min.

Note f: Measured  $\pm 200\text{mV}$  from steady state output voltage. Load capacitance is 5pF.

Note g:  $\bar{E}$  and  $\bar{W}$  must transition between  $V_{IH}$  to  $V_{IL}$  or  $V_{IL}$  to  $V_{IH}$  in a monotonic fashion.

Note j: Parameter guaranteed but not tested.

### READ CYCLE 1<sup>c,d</sup>

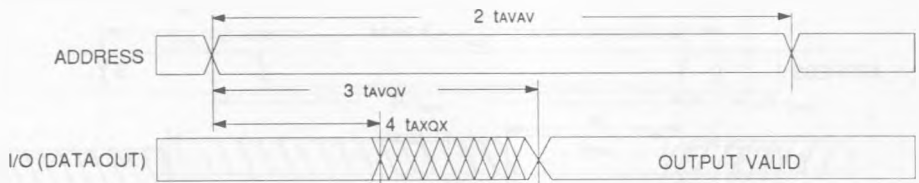

### READ CYCLE 2<sup>c</sup>

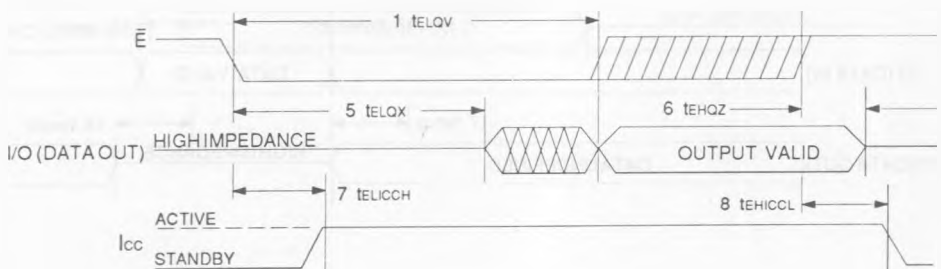

**RECOMMENDED AC OPERATING CONDITIONS** (-55°C ≤ T<sub>A</sub> ≤ +125°C) (V<sub>CC</sub> = 5.0V ±10%)

**WRITE CYCLE 1:  $\bar{W}$  CONTROLLED<sup>g,h</sup>**

NO.	SYMBOL		PARAMETER	IMS1620M-45		IMS1620M-55		IMS1620M-70		UNITS	NOTES
	Standard	Alternate		MIN	MAX	MIN	MAX	MIN	MAX		
9	t <sub>AVAV</sub>	t <sub>WC</sub>	Write Cycle Time	40		50		60		ns	
10	t <sub>WLWH</sub>	t <sub>WP</sub>	Write Pulse Width	30		40		50		ns	
11	t <sub>ELWH</sub>	t <sub>EW</sub>	Chip Enable to End of Write	30		40		50		ns	
12	t <sub>DVWH</sub>	t <sub>DW</sub>	Data Setup to End of Write	20		25		30		ns	
13	t <sub>WHDX</sub>	t <sub>DH</sub>	Data Hold after End of Write	0		0		0		ns	
14	t <sub>AVWH</sub>	t <sub>AW</sub>	Address Setup to End of Write	30		40		50		ns	
15	t <sub>AVWL</sub>	t <sub>AS</sub>	Address Setup to Start of Write	0		0		0		ns	
16	t <sub>WHAX</sub>	t <sub>WR</sub>	Address Hold after End of Write	0		0		0		ns	
17	t <sub>WLOZ</sub>	t <sub>WZ</sub>	Write Enable to Output Disable	0	15	0	20	0	25	ns	f, j
18	t <sub>WHQX</sub>	t <sub>OW</sub>	Output Active after End of Write	5		5		5		ns	i, j

Note f: Measured ±200mV from steady state output voltage. Load capacitance is 5pF.

Note g:  $\bar{E}$  and  $\bar{W}$  must transition between V<sub>IH</sub> to V<sub>IL</sub> or V<sub>IL</sub> to V<sub>IH</sub> in a monotonic fashion.

Note h:  $\bar{E}$  or  $\bar{W}$  must be ≥ V<sub>IH</sub> during address transitions.

Note i: If  $\bar{W}$  is low when  $\bar{E}$  goes low, the outputs remain in the high impedance state.

Note j: Parameter guaranteed but not tested.

**WRITE CYCLE 1**

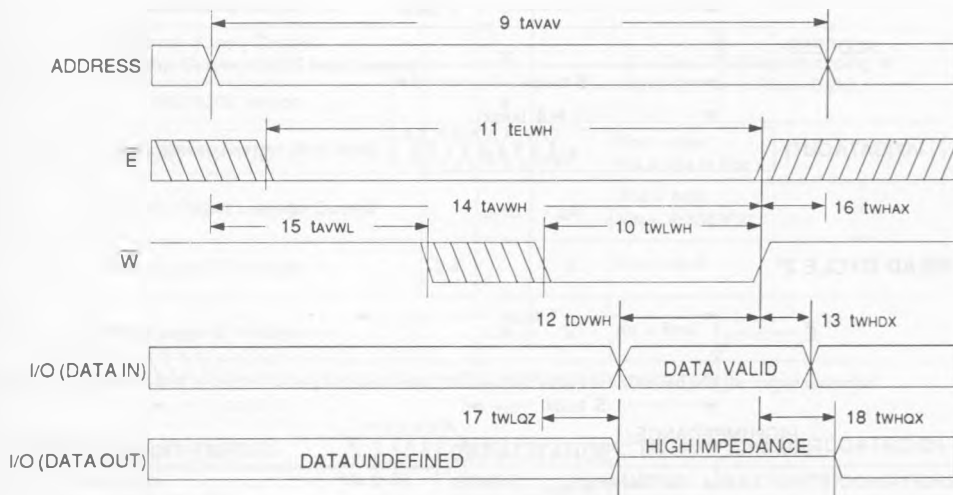

**RECOMMENDED AC OPERATING CONDITIONS** (-55°C ≤ Ta ≤ 125°C) (Vcc = 5.0V ±10%)

**WRITE CYCLE 2:  $\bar{E}$  CONTROLLED<sup>g, h</sup>**

NO.	SYMBOL		PARAMETER	IMS1620M-45		IMS1620M-55		IMS1620M-70		UNITS	NOTES
	Standard	Alternate		MIN	MAX	MIN	MAX	MIN	MAX		
19	t <sub>AVAV</sub>	t <sub>wc</sub>	Write Cycle Time	40		50		60		ns	
20	t <sub>wLEH</sub>	t <sub>wP</sub>	Write Pulse Width	30		40		50		ns	
21	t <sub>ELEH</sub>	t <sub>cw</sub>	Chip Enable to End of Write	30		40		50		ns	
22	t <sub>DVEH</sub>	t <sub>DW</sub>	Data Setup to End of Write	20		25		30		ns	
23	t <sub>EHDX</sub>	t <sub>DH</sub>	Data Hold after End of Write	0		0		0		ns	
24	t <sub>AVEH</sub>	t <sub>AW</sub>	Address Setup to End of Write	30		40		50		ns	
25	t <sub>EHAX</sub>	t <sub>WR</sub>	Address Hold after End of Write	0		0		0		ns	
26	t <sub>AVEL</sub>	t <sub>AS</sub>	Address Setup to Start of Write	0		0		0		ns	
27	t <sub>wLOZ</sub>	t <sub>wZ</sub>	Write Enable to Output Disable	0	15	0	20	0	25	ns	f, j

Note f: Measured ±200mV from steady state output voltage. Load capacitance is 5pF.

Note g:  $\bar{E}$  and  $\bar{W}$  must transition between V<sub>H</sub> to V<sub>L</sub> or V<sub>L</sub> to V<sub>H</sub> in a monotonic fashion.

Note h:  $\bar{E}$  or  $\bar{W}$  must be ≥ V<sub>IH</sub> during address transitions.

Note i: If  $\bar{W}$  is low when  $\bar{E}$  goes low, the outputs remain in the high impedance state.

Note j: Parameter guaranteed but not tested.

**WRITE CYCLE 2**

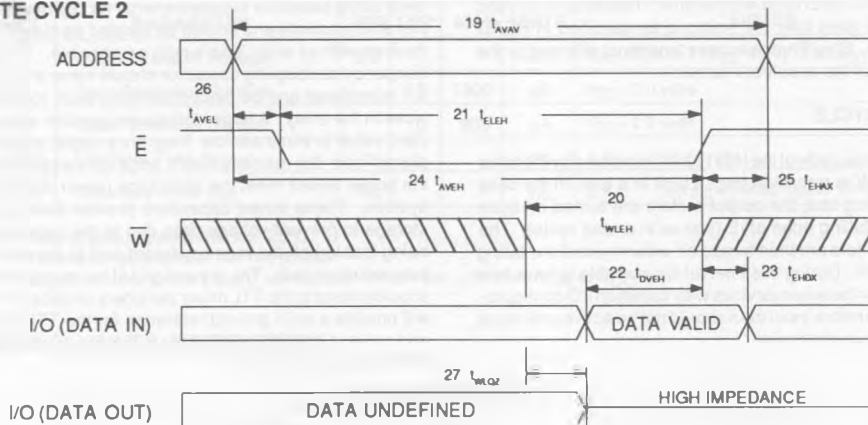

## DEVICE OPERATION

The IMS1620M has two control inputs, a Chip Enable (/E) and Write Enable (/W), 14 address inputs (A0 - A13), and four Data I/O pins.

The /E input controls device selection as well as active and standby modes. With /E low, the device is selected and the 14 address inputs are decoded to select one 4-bit word out of 16,384. Read and Write operations on the memory cells are controlled by the /W input. With /E high, the device is deselected, the outputs are disabled and the power consumption is reduced to less than one-third of the active mode power with TTL levels and even lower with CMOS levels.

### READ CYCLE

A read cycle is defined as  $/W \geq V_{IH\ min}$  with  $/E \leq V_{IL\ max}$ . Read access time is measured from either /E going low or from valid address.

The READ CYCLE 1 waveform shows a read access that is initiated by a change in the address inputs while /E is low. The outputs remain active throughout READ CYCLE 1 and is valid at the specified address access time. The address inputs may change at access time and long as /E remains low, the cycle time is equal to the address access time.

The READ CYCLE 2 waveform shows a read access that is initiated by /E going low. As long as address is stable when /E goes low, valid data is at the outputs at the specified Chip Enable Access time. If address is not valid when /E goes low, the timing is as specified in READ CYCLE 1. Chip Enable access time is not affected by the duration of the deselect interval.

### WRITE CYCLE

The write cycle of the IMS1620M is initiated by the latter of /E or /W to transition from a high to a low. In the case of /W falling last, the output buffers are turned on  $t_{EOL}$  after the falling edge of /E (just as in a read cycle). The output buffers are then turned off within  $2t_{LOZ}$  of the falling edge of /W. During this interval it is possible to have bus contention between devices with common I/O configurations. Therefore input data should not be active until  $t_{LOZ}$  to avoid bus contention.

WRITE CYCLE 1 waveform shows a write cycle terminated by /W going high. Data set-up and hold times are referenced to the rising edge of /W. When /W goes high at the end of the cycle with /E active, the output of the memory becomes active. The data from the memory will be the same as the input data unless the input data or address changes.

WRITE CYCLE 2 waveform shows a write cycle terminated by /E going high. Data set-up and hold times are referenced to the rising edge of /E. With /E high the outputs remain in the high impedance state.

## POWER DISTRIBUTION

The recommended power distribution scheme combines proper power trace layout and placement of decoupling capacitors to maintain the operating margins of the IMS1620M. The impedance in the decoupling path from the power pin through the decoupling capacitor to the ground pin should be kept to a minimum. The impedance of this path is determined by the series impedance of the power line inductance and the inductance and reactance of the decoupling capacitor.

Current transients associated with the operation of any high speed device have very high frequency components, so line inductance is the dominating factor. To reduce the line inductance, the power trace and ground trace should be gridded or provided by separate power planes. The decoupling capacitor supplies energy for high frequency current transients and should be located as close to the devices with as short lead length as possible. The high frequency decoupling capacitor should have a value of 0.1 microfarad and be placed between each row of devices in the array. A larger tantalum capacitor of a sufficient value to eliminate low frequency ripple, should be placed near the memory board edge connection where the power traces meet the backplane power distribution system. These larger capacitors provide bulk energy storage to prevent voltage drop due to the main supply being located off the memory board and at the end of a long inductive path. The ground grid of the memory array should extend to the TTL driver periphery circuit area. This will provide a solid ground reference for the TTL drivers and prevent loss of operating margin of the drivers due to differential ground noise.

## TERMINATION

Trace lines on a memory board in the array look to TTL driver signals like low impedance, unterminated transmission lines. In order to reduce or eliminate the reflections of the TTL signals propagating down the lines, especially low going TTL signals, line termination is recommended. The termination may be either series or parallel.

The recommended technique is to use series termination. The series termination technique has the advantage of drawing no DC current and using a minimum number of components. This is accomplished by placing a series resistor in the signal line at the output of the TTL driver to

dampen the reflection on the line. The resistor should be placed as close to the driver package as is practical. The line should be kept short by placing the driver-termination combination close to the memory array.

Some experimentation will have to be done to find the proper value to use for the series termination to minimize reflections, but generally a series resistor in the 10 to 33 ohm range will be required. Because each design will result in a different signal impedance, a resistor of predetermined value may not properly match the signal path impedance. The proper value of resistance should therefore be selected empirically.

## DATA RETENTION (L version, only) ( $-55^{\circ}\text{C} \leq T_A \leq 125^{\circ}\text{C}$ )

SYMBOL	PARAMETER	MIN	TYP*	MAX	UNITS	NOTES
$V_{DR}$	Data Retention Voltage	2.0			volts	$V_{IN} \leq 0.2\text{V}$ or $\geq (V_{CC}-0.2\text{V})$ $\bar{E} \geq (V_{CC}-0.2\text{V})$
$I_{CCDR1}$	Data Retention Current		15	1200	$\mu\text{A}$	$V_{CC} = 3.0$ volts
$I_{CCDR2}$	Data Retention Current		10	800	$\mu\text{A}$	$V_{CC} = 2.0$ volts
$t_{EHVCC}$	Deselect Time ( $t_{CDR}$ )	0			ns	j, k
$t_{VCHEL}$	Recovery Time ( $t_R$ )	$t_{RC}$			ns	j, k ( $t_{RC}$ = Read Cycle Time)

\*Typical data retention parameters at 25°C.

Note j: Parameter guaranteed but not tested.

Note k: Supply recovery rate should not exceed 100mV per  $\mu\text{S}$  from  $V_{DR}$  to  $V_{CC}$  min.

## LOW $V_{CC}$ DATA RETENTION

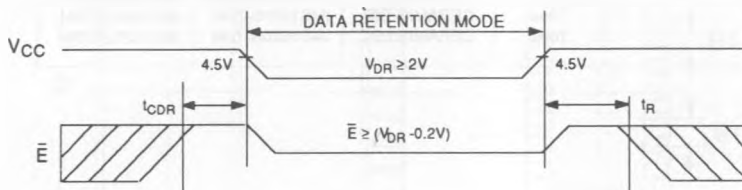

Type	Package	Lead finish
A	Formed flat-pack	gold
B	Formed flat-pack	solder
C	LCC	gold
D	Cerdip	solder
E	Small outline, J-bend	solder
G	PGA	gold
H	Small outline, Gull wing	solder
J	PLCC, J-bend	solder
K	Sidebrazed ceramic DIP	solder
N	Ceramic LCC	solder
P	Plastic DIP	solder
S	Sidebrazed ceramic DIP	gold
T	(Skinny) Flat-pack	solder
W	Ceramic LCC	gold
Y	(Skinny) Flat-pack	gold

FIGURE 1. OUTPUT LOAD

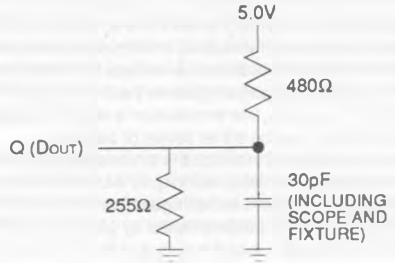

TRUTH TABLE

E	W	Q	MODE
H	X	HI-Z	Standby (Isb)
L	H	Dout	Read
L	L	HI-Z	Write

ORDERING INFORMATION

DEVICE	SPEED	PACKAGE	PART NUMBER	
			STANDARD	LOW POWER
IMS 1620M IMS1620LM	45ns	CERAMIC DIP	IMS1620S-45M	IMS1620LS45M
	45ns	CERAMIC LCC	IMS1620N-45M	IMS1620LN45M
	55ns	CERAMIC DIP	IMS1620S-55M	IMS1620LS55M
	55ns	CERAMIC LCC	IMS1620N-55M	IMS1620LN55M
	70ns	CERAMIC DIP	IMS1620S-70M	IMS1620LS70M
	70ns	CERAMIC LCC	IMS1620N-70M	IMS1620LN70M



PACKAGING INFORMATION

22 Pin Ceramic Dual-In-Line

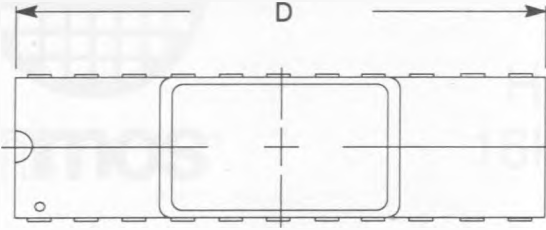

Dim	Inches		mm	
	Nom	Tol	Nom	Tol
A	.118	.010	2.997	.254
A1	.035	.015	.889	.381
B	.018	.003	.457	.152
B1	.060	Typ	1.524	Max
D	1.10	.013	27.94	.330
E	.315	.010	8.001	.254
E1	.295	.015	7.493	.381
e1	.100	.010	2.54	.254
L	.145	.020	3.683	.508

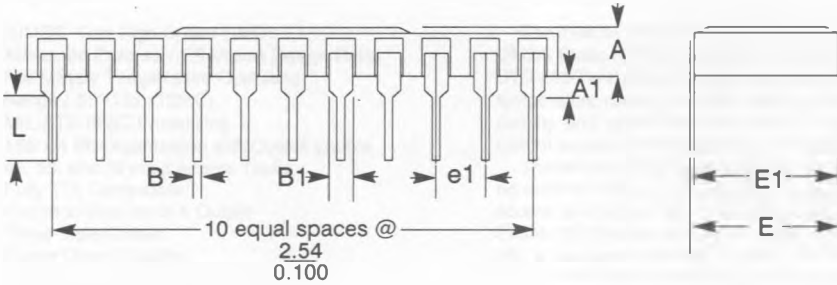

22 Pin Leadless Chip Carrier

Dim	Inches		mm		Notes
	Nom	Tol	Nom	Tol	
A	.071	.007	1.803	.178	
B1	.025	.003	.635	.076	
D	.490	.006	13.446	.152	
E	.290	.006	7.366	.152	
e1	.050		1.270		

