

Fast-Settling FET-Input INSTRUMENTATION AMPLIFIER

FEATURES

- LOW BIAS CURRENT: 50pA max
- FAST SETTling: 4 μ s to 0.01%
- HIGH CMR: 106dB min; 90dB at 10kHz
- INTERNAL GAINS: 1, 10, 100, 200, 500
- VERY LOW GAIN DRIFT: 10 to 50ppm/ $^{\circ}$ C
- LOW OFFSET DRIFT: 2 μ V/ $^{\circ}$ C
- LOW COST
- PINOUT SIMILAR TO AD524 AND AD624

APPLICATIONS

- MULTIPLEXED INPUT DATA ACQUISITION SYSTEM
- FAST DIFFERENTIAL PULSE AMPLIFIER
- HIGH SPEED GAIN BLOCK
- AMPLIFICATION OF HIGH IMPEDANCE SOURCES

DESCRIPTION

The INA110 is a versatile monolithic FET-input instrumentation amplifier. Its current-feedback circuit topology and laser trimmed input stage provide excellent dynamic performance and accuracy. The INA110 settles in 4 μ s to 0.01%, making it ideal for high speed or multiplexed-input data acquisition systems.

Internal gain-set resistors are provided for gains of 1, 10, 100, 200, and 500V/V. Inputs are protected for differential and common-mode voltages up to $\pm V_{CC}$. Its very high input impedance and low input bias current make the INA110 ideal for applications requiring input filters or input protection circuitry.

The INA110 is available in 16-pin plastic and ceramic DIPs, and in the SOL-16 surface-mount package. Military, industrial and commercial temperature range grades are available.

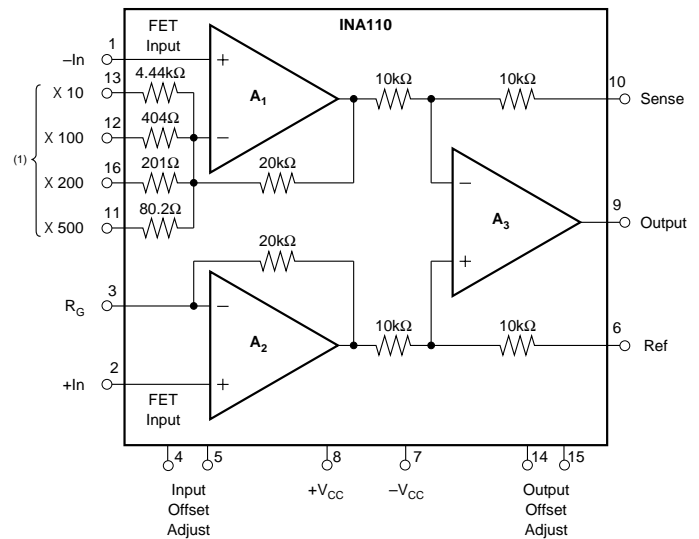

NOTE: (1) Connect to R_G for desired gain.



Please be aware that an important notice concerning availability, standard warranty, and use in critical applications of Texas Instruments semiconductor products and disclaimers thereto appears at the end of this data sheet.

All trademarks are the property of their respective owners.

ELECTRICAL CHARACTERISTICS

At +25°C, $\pm V_{CC} = 15\text{VDC}$, and $R_L = 2\text{k}\Omega$, unless otherwise specified.

PARAMETER	CONDITIONS	INA110AG			INA110BG, SG			INA110KP, KU			UNITS
		MIN	TYP	MAX	MIN	TYP	MAX	MIN	TYP	MAX	
GAIN											
Range of Gain		1	*	800	*		*	*	*		V/V
Gain Equation ⁽¹⁾					$G = 1 + [40\text{k}/(R_G + 50\Omega)]$						V/V
Gain Error, DC: G = 1			0.002	0.04		*	0.02		*	*	%
G = 10			0.01	0.1		0.005	0.05		*	*	%
G = 100			0.02	0.2		0.01	0.1		*	*	%
G = 200			0.04	0.4		0.02	0.2		*	*	%
G = 500			0.1	1		0.05	0.5		*	*	%
Gain Temp. Coefficient: G = 1			±3	±20		*	±10		*	*	ppm/°C
G = 10			±4	±20		±2	±10		*	*	ppm/°C
G = 100			±6	±40		±3	±20		*	*	ppm/°C
G = 200			±10	±60		±5	±30		*	*	ppm/°C
G = 500			±25	±100		±10	±50		*	*	ppm/°C
Nonlinearity, DC: G = 1			±0.001	±0.01		±0.0005	±0.005		*	*	% of FS
G = 10			±0.002	±0.01		±0.001	±0.005		*	*	% of FS
G = 100			±0.004	±0.02		±0.002	±0.01		*	*	% of FS
G = 200			±0.006	±0.02		±0.003	±0.01		*	*	% of FS
G = 500			±0.01	±0.04		±0.005	±0.02		*	*	% of FS
OUTPUT											
Voltage, $R_L = 2\text{k}\Omega$	Over Temperature	±10	±12.7		*	*		*	*		V
Current	Over Temperature	±5	±25		*	*		*	*		mA
Short-Circuit Current			±25			*			*		mA
Capacitive Load	Stability		5000			*			*		pF
INPUT OFFSET VOLTAGE⁽²⁾											
Initial Offset: G, P			±(100 + 1000/G)	±(500 + 5000/G)		±(50 + 600/G)	±(250 + 3000/G)		*	*	μV
U									±(200 + 2000/G)	±(1000 + 5000/G)	μV
vs Temperature			±(2 + 20/G)	±(5 + 100/G)		±(1 + 10/G)	±(2 + 50/G)		*	*	μV/°C
vs Supply	$V_{CC} = \pm 6\text{V to } \pm 18\text{V}$		±(4 + 60/G)	±(30 + 300/G)		±(2 + 30/G)	±(10 + 180/G)		*	*	μV/V
BIAS CURRENT											
Initial Bias Current	Each Input		20	100		10	50		*	*	pA
Initial Offset Current			2	50		1	25		*	*	pA
Impedance: Differential			$5 \times 10^{12} 6$			*			*	*	Ω pF
Common-Mode			$2 \times 10^{12} 1$			*			*	*	Ω pF
VOLTAGE RANGE											
Range, Linear Response	$V_{IN \text{ Diff.}} = 0\text{V}^{(3)}$	±10	±12					*	*		V
CMR with 1kΩ Source Imbalance:											
G = 1	DC	70	90		80	100		*	*		dB
G = 10	DC	87	104		96	112		*	*		dB
G = 100	DC	100	110		106	116		*	*		dB
G = 200	DC	100	110		106	116		*	*		dB
G = 500	DC	100	110		106	116		*	*		dB
INPUT NOISE⁽⁴⁾											
Voltage, $f_O = 10\text{kHz}$			10			*			*		$\text{nV}/\sqrt{\text{Hz}}$
$f_B = 0.1\text{Hz to } 10\text{Hz}$			1			*			*		μV_{PP}
Current, $f_O = 10\text{kHz}$			1.8			*			*		$\text{fA}/\sqrt{\text{Hz}}$
OUTPUT NOISE⁽⁴⁾											
Voltage, $f_O = 10\text{kHz}$			65			*			*		$\text{nV}/\sqrt{\text{Hz}}$
$f_B = 0.1\text{Hz to } 10\text{Hz}$			8			*			*		μV_{PP}
DYNAMIC RESPONSE											
Small Signal: G = 1	-3dB		2.5			*			*		MHz
G = 10			2.5			*			*		MHz
G = 100			470			*			*		kHz
G = 200			240			*			*		kHz
G = 500			100			*			*		kHz
Full Power	$V_{OUT} = \pm 10\text{V}$, G = 2 to 100	190	270		*	*			*	*	kHz
Slew Rate	G = 2 to 100	12	17		*	*			*	*	V/μs
Settling Time:											
0.1%, G = 1	$V_O = 20\text{V Step}$		4			*			*		μs
G = 10			2			*			*		μs
G = 100			3			*			*		μs
G = 200			5			*			*		μs
G = 500			11			*			*		μs

ELECTRICAL CHARACTERISTICS (Cont)

At +25°C, ±V_{CC} 15VDC, and R_L = 2KΩ, unless otherwise specified.

PARAMETER	CONDITIONS	INA110AG			INA110BG, SG			INA110KP, KU			UNITS
		MIN	TYP	MAX	MIN	TYP	MAX	MIN	TYP	MAX	
DYNAMIC RESPONSE (CONT)											
Settling Time:	V _O = 20V Step										
0.01%, G = 1			5	12.5		*	*		*		μs
G = 10			3	7.5		*	*		*		μs
G = 100			4	7.5		*	*		*		μs
G = 200			7	12.5		*	*		*		μs
G = 500		16	25		*	*		*		μs	
Recovery ⁽⁵⁾	50% Overdrive		1			*			*		μs
POWER SUPPLY											
Rated Voltage	V _O = 0V		±15			*	*		*		V
Voltage Range		±6		±18	*		*	*	*	*	V
Quiescent Current			±3	±4.5		*	*		*	*	mA
TEMPERATURE RANGE											
Specification: P, U		-25		+85	*		*	0		+70	°C
G					-55		+125				°C
Operation		-55		+125	*		*	-25		+85	°C
Storage		-65		+150	*		*	-40		+85	°C
θ _{JA}			100			*			*		°C/W

* Same as INA110AG.

NOTES: (1) Gains other than 1, 10, 100, 200, and 500 can be set by adding an external resistor, R_G, between pin 3 and pins 11, 12 and 16. Gain accuracy is a function of R_G and the internal resistors which have a ±20% tolerance with 20ppm/°C drift. (2) Adjustable to zero. (3) For differential input voltage other than zero, see Typical Characteristics. (4) $V_{NOISE RTI} = \sqrt{V_{N INPUT}^2 + (V_{N OUTPUT}/Gain)^2}$. (5) Time required for output to return from saturation to linear operation following the removal of an input overdrive voltage.

TYPICAL CHARACTERISTICS

At $T_A = +25^\circ\text{C}$ and $\pm V_{CC} = 15\text{VDC}$, unless otherwise noted.

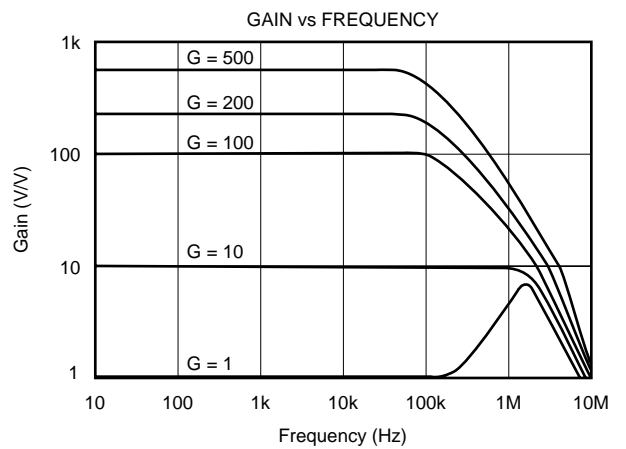
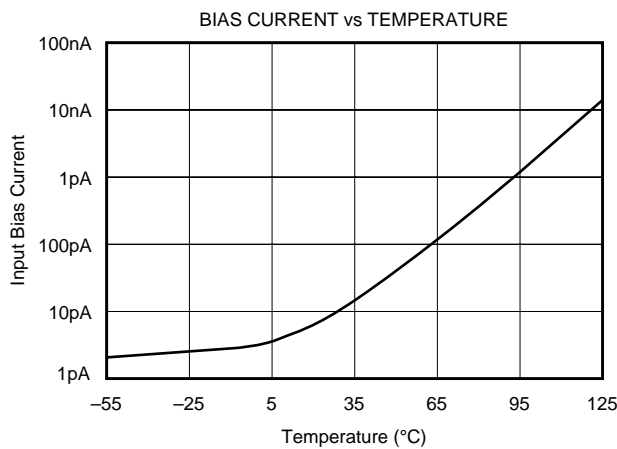
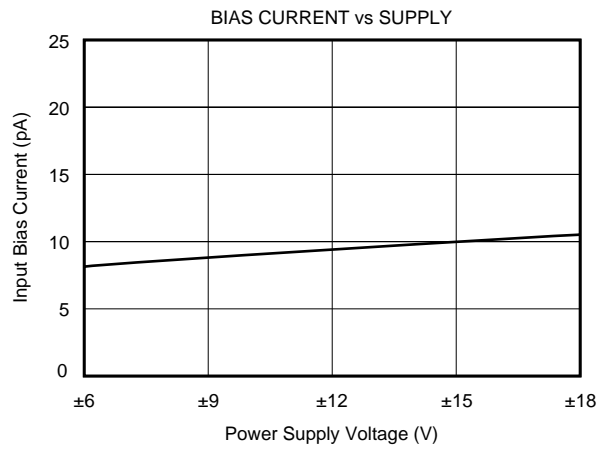
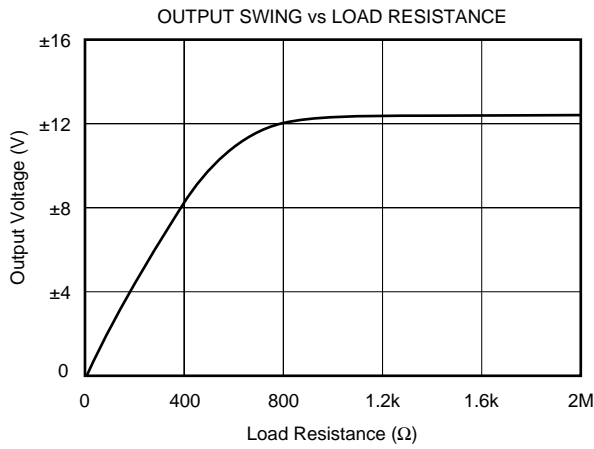
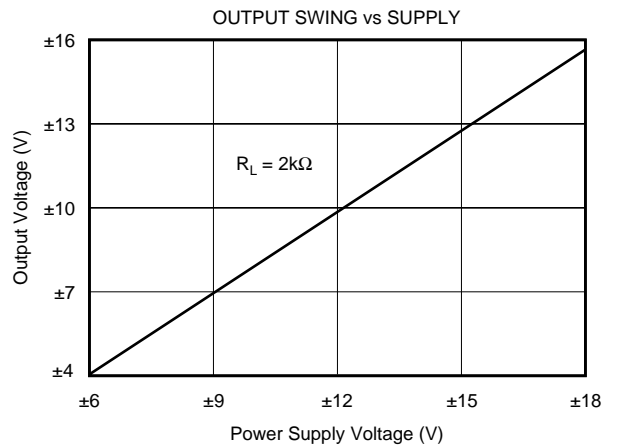
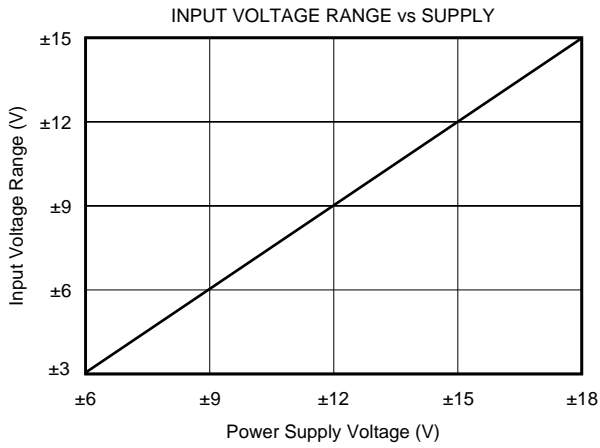

TYPICAL CHARACTERISTICS (Cont)

At $T_A = +25^\circ\text{C}$ and $\pm V_{CC} = 15\text{VDC}$, unless otherwise noted.

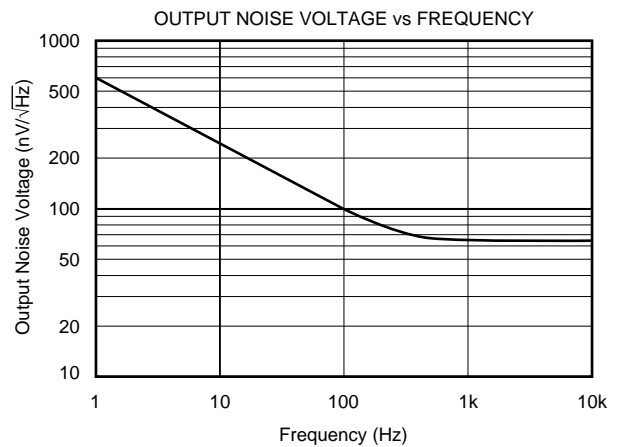
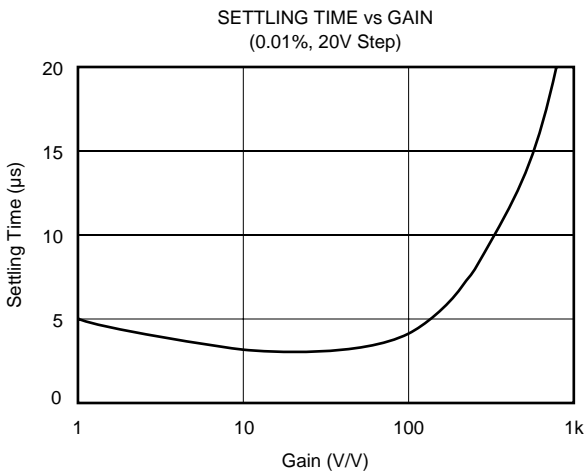
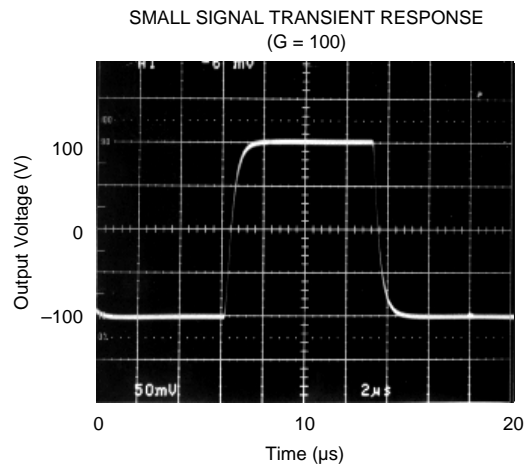
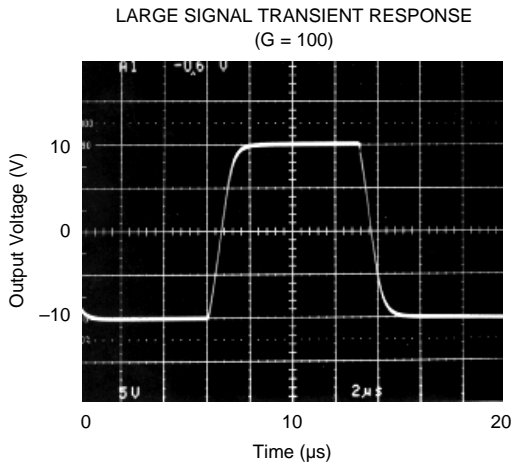
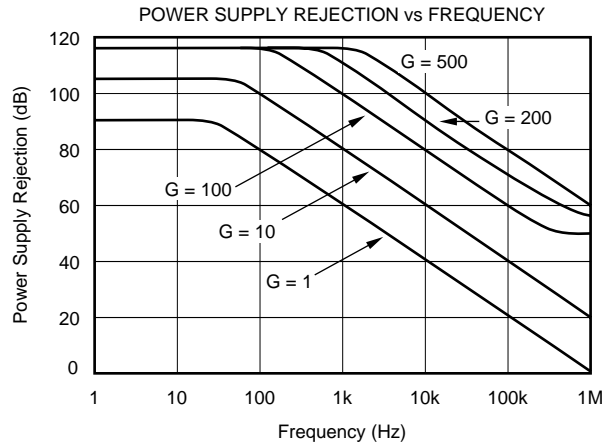
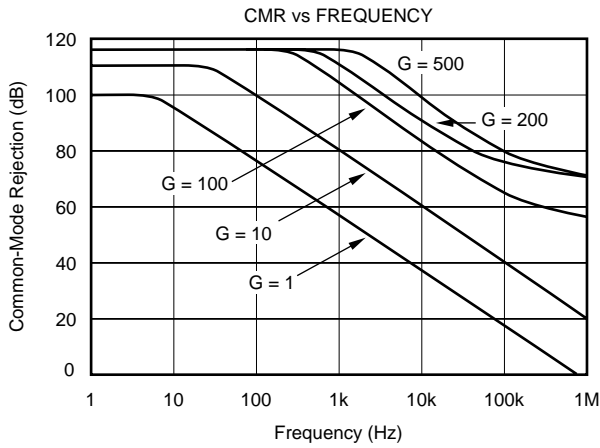

TYPICAL CHARACTERISTICS (Cont)

At $T_A = +25^\circ\text{C}$ and $\pm V_{CC} = 15\text{VDC}$, unless otherwise noted.

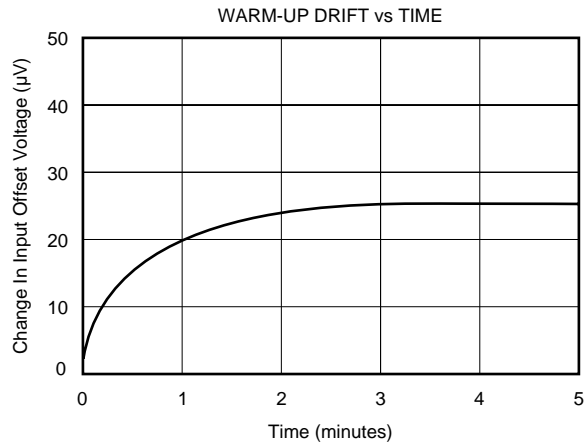
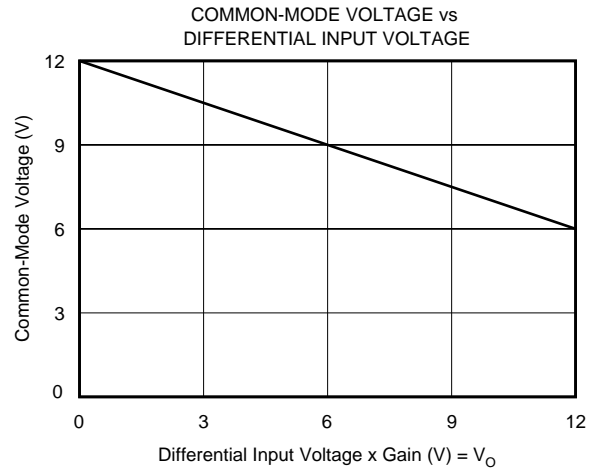
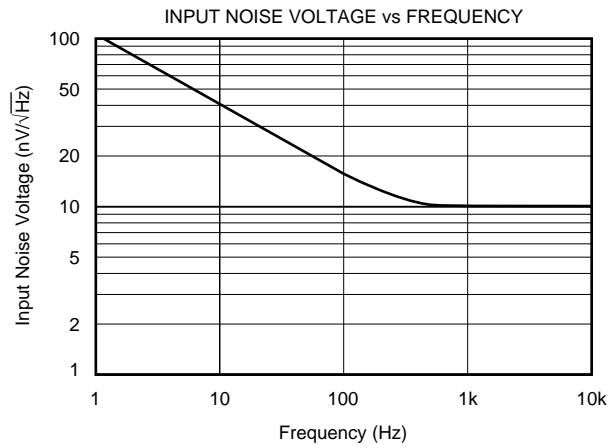

DISCUSSION OF PERFORMANCE

A simplified diagram of the INA110 is shown on the first page. The design consists of the classical three operational amplifier configuration using current-feedback type op amps with precision FET buffers on the input. The result is an instrumentation amplifier with premium performance not normally found in integrated circuits.

The input section (A_1 and A_2) incorporates high performance, low bias current, and low drift amplifier circuitry. The amplifiers are connected in the noninverting configuration to provide high input impedance ($10^{12}\Omega$). Laser-trimming is used to achieve low offset voltage. Input cascoding assures low bias current and high CMR. Thin-film resistors on the integrated circuit provide excellent gain accuracy and temperature stability.

The output section (A_3) is connected in a unity-gain difference amplifier configuration. Precision matching of the four $10k\Omega$ resistors, especially over temperature and time, assures high common-mode rejection.

BASIC POWER SUPPLY AND SIGNAL CONNECTIONS

Figure 1 shows the proper connections for power supply and signal. Supplies should be decoupled with $1\mu F$ tantalum capacitors as close to the amplifier as possible. To avoid gain and CMR errors introduced by the external circuit, connect grounds as indicated, being sure to minimize ground resistance. Resistance in series with the reference (pin 6) will degrade CMR. To maintain stability, avoid capacitance from the output to the gain set, offset adjust, and input pins.

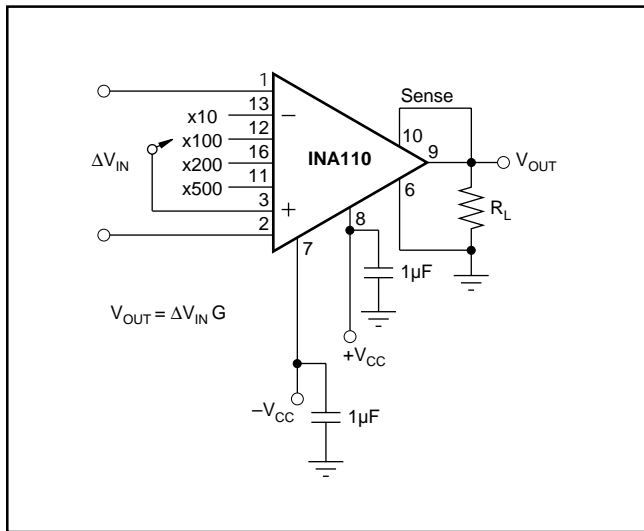

FIGURE 1. Basic Circuit Connection.

OFFSET ADJUSTMENT

Figure 2 shows the offset adjustment circuit for the INA110. Both the offset of the input stage and output stage can be adjusted separately. Notice that the offset referred to the

INA110's input (RTI) is the offset of the input stage plus the offset of the output stage divided by the gain of the input stage. This allows specification of offset independent of gain.

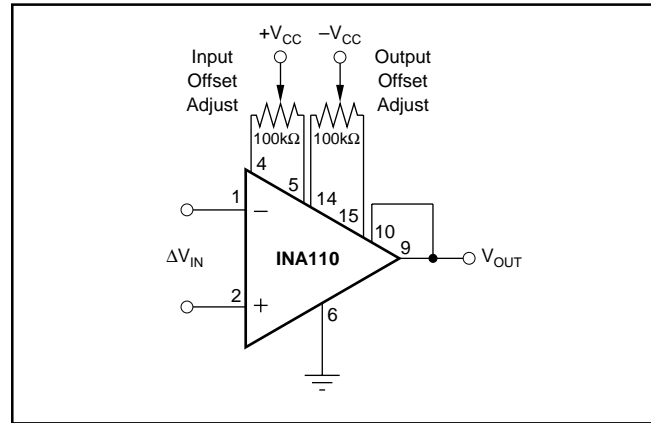

FIGURE 2. Offset Adjustment Circuit.

For systems using computer autozeroing techniques, neither offset nor offset drift are of concern. In many other applications, the factory-trimmed offset gives excellent results. When greater accuracy is desired, one adjustment is usually sufficient. In high gains (>100) adjust only the input offset, and in low gains the output offset. For higher precision in all gains, both can be adjusted by first selecting high gain and adjusting input offset and then low gain and adjusting output offset. The offset adjustment will, however, add to the drift by approximately $0.33\mu V/^\circ C$ per $100\mu V$ of input offset voltage that is adjusted. Therefore, care should be taken when considering use of adjustment.

Output offsetting can be accomplished as shown in Figure 3 by applying a voltage to the reference (pin 6) through a buffer. This limits the resistance in series with pin 6 to minimize CMR error. Be certain to keep this resistance low. Note that the offset error can be adjusted at this reference point with no appreciable degradation in offset drift.

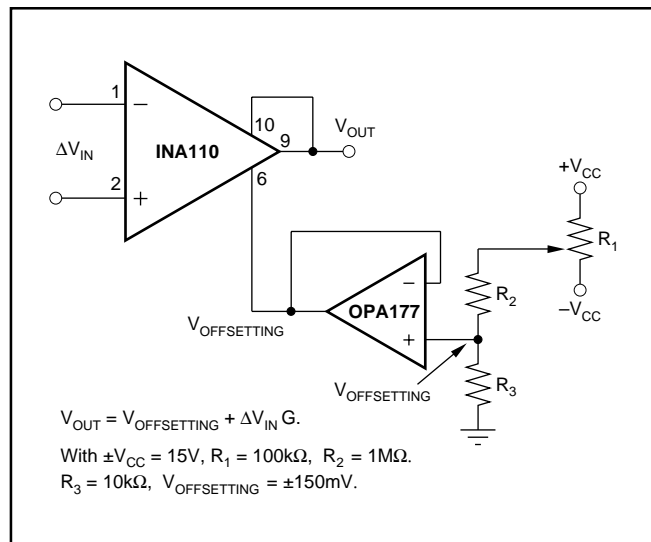

FIGURE 3. Output Offsetting.

GAIN SELECTION

Gain selection is accomplished by connecting the appropriate pins together on the INA110. Table I shows possible gains from the internal resistors. Keep the connections as short as possible to maintain accuracy.

GAIN	CONNECT PIN 3 TO PIN	GAIN ACCURACY (%)	GAIN DRIFT (ppm/°C)
The following gains have assured accuracy:			
1	none	0.02	10
10	13	0.05	10
100	12	0.1	20
200	16	0.2	30
500	11	0.5	50
The following gains have typical accuracy as shown:			
300	12, 16	0.25	10
600	11, 12	0.25	40
700	11, 16	2	40
800	11, 12, 16	2	80

TABLE I. Internal Gain Connections.

Gains other than 1, 10, 100, 200, and 500 can be set by adding an external resistor, R_G , between pin 3 and pins 12, 16, and 11. Gain accuracy is a function of R_G and the internal resistors which have a $\pm 20\%$ tolerance with 20ppm/°C drift. The equation for choosing R_G is shown below.

$$R_G = \frac{40k\Omega}{G - 1} - 50\Omega$$

Gain can also be changed in the output stage by adding resistance to the feedback loop shown in Figure 4. This is useful for increasing the total gain or reducing the input stage gain to prevent saturation of input amplifiers.

The output gain can be changed as shown in Table II. Matching of R_1 and R_3 is required to maintain high CMR. R_2 sets the gain with no effect on CMR.

OUTPUT STAGE GAIN	R_1 AND R_3	R_2
2	1.2k Ω	2.74k Ω
5	1k Ω	511 Ω
10	1.5k Ω	340 Ω

TABLE II. Output Stage Gain Control.

COMMON-MODE INPUT RANGE

It is important not to exceed the input amplifiers' dynamic range (see Typical Characteristics). The differential input signal and its associated common-mode voltage should not cause the output of A_1 and A_2 (input amplifiers) to exceed approximately $\pm 10V$ with $\pm 15V$ supplies or nonlinear operation will result. Such large common-mode voltages, when the INA110 is in high gain, can cause saturation of the input stage even though the differential input is very small. This can be avoided by reducing the input stage gain and increasing the output stage gain with an H pad attenuator (see Figure 4).

OUTPUT SENSE

An output sense has been provided to allow greater accuracy in connecting the load. By attaching this feedback point to the load at the load site, IR drops due to load currents that

are eliminated since they are inside the feedback loop. Proper connection is shown in Figure 1. When more current is to be supplied, a power booster can be placed within the feedback loop as shown in Figure 5. Buffer errors are minimized by the loop gain of the output amplifier.

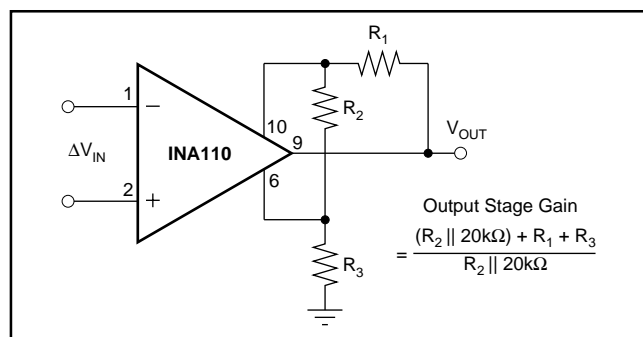

FIGURE 4. Gain Adjustment of Output Stage Using H Pad Attenuator.

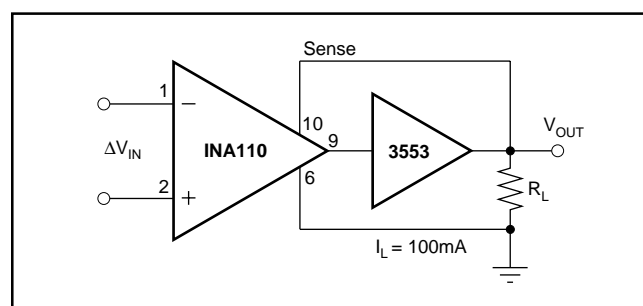

FIGURE 5. Current Boosting the Output.

LOW BIAS CURRENT OF FET INPUT ELIMINATES DC ERRORS

Because the INA110 has FET inputs, bias currents drawn through input source resistors have a negligible effect on DC accuracy. The picoamp levels produce no more than microvolts through megohm sources. Thus, input filtering and input series protection are readily achievable.

A return path for the input bias currents must always be provided to prevent charging of stray capacitance. Otherwise, the output can wander and saturate. A 1M Ω to 10M Ω resistor from the input to common will return floating sources such as transformers, thermocouples, and AC-coupled inputs (see Applications section).

DYNAMIC PERFORMANCE

The INA110 is a fast-settling FET input instrumentation amplifier. Therefore, careful attention to minimize stray capacitance is necessary to achieve specified performance. High source resistance will interact with input capacitance to reduce the overall bandwidth. Also, to maintain stability, avoid capacitance from the output to the gain set, offset adjust, and input pins.

Applications with balanced-source impedance will provide the best performance. In some applications, mismatched source impedances may be required. If the impedance in the

negative input exceeds that in the positive input, stray capacitance from the output will create a net negative feedback and improve the circuit stability. If the impedance in the positive input is greater, the feedback due to stray capacitance will be positive and instability may result. The degree of positive feedback depends upon source impedance imbalance, operating gain, and board layout. The addition of a small bypass capacitor of 5pF to 50pF directly between the inputs of the IA will generally eliminate any positive feedback. CMR errors due to the input impedance mismatch will also be reduced by the capacitor.

The INA110 is designed for fast settling with easy gain selection. It has especially excellent settling in high gain. It can also be used in fast-settling unity-gain applications. As with all such amplifiers, the INA110 does exhibit significant gain peaking when set to a gain of 1. It is, however, unconditionally stable. The gain peaking can be cancelled by band-limiting the negative input to 400kHz with a simple external RC circuit for applications requiring flat response. CMR is not affected by the addition of the 400kHz RC in a gain of 1.

Another distinct advantage of the INA110 is the high frequency CMR response. High frequency noise and sharp common-mode transients will be rejected. To preserve AC CMR, be sure to minimize stray capacitance on the input lines. Matching the RCs in the two inputs will help to maintain high AC CMR.

APPLICATIONS

In addition to general purpose uses, the INA110 is designed to accurately handle two important and demanding applications: (1) inputs with high source impedances such as capacitance/crystal/photodetector sensors and low-pass filters and series-input protection devices, and (2) rapid-scanning data acquisition systems requiring fast settling time. Because the user has access to the output sense, current sources can also be constructed using a minimum of external components. Figures 6 through 19 show application circuits.

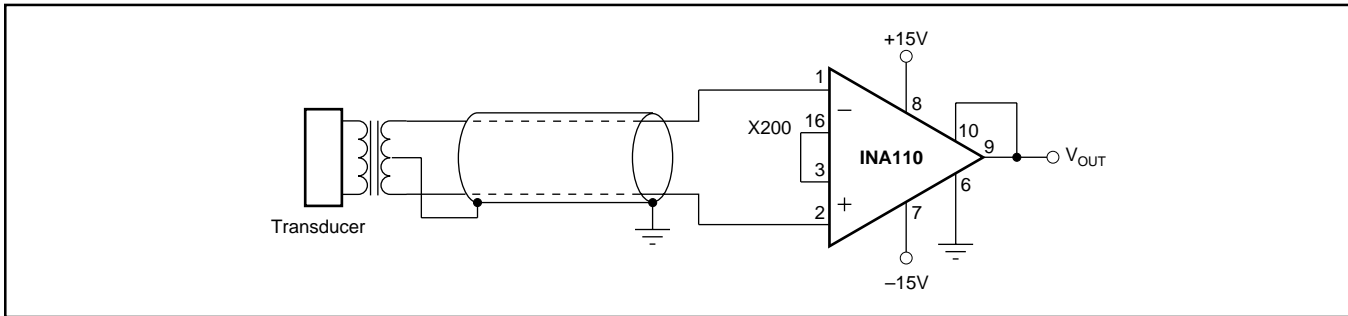

FIGURE 6. Transformer-Coupled Amplifier.

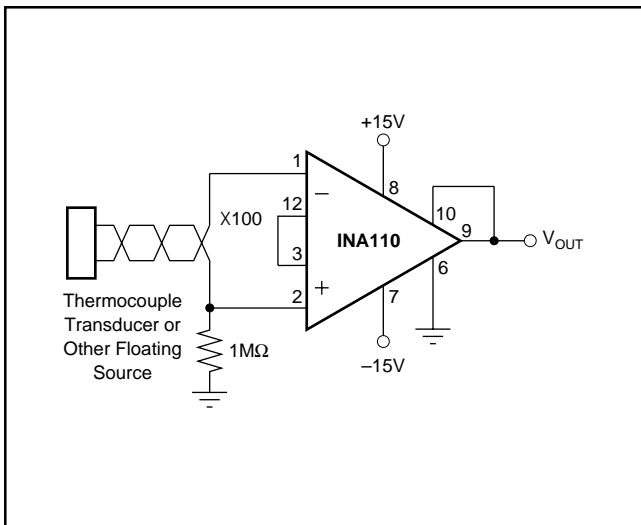

FIGURE 7. Floating Source Instrumentation Amplifier.

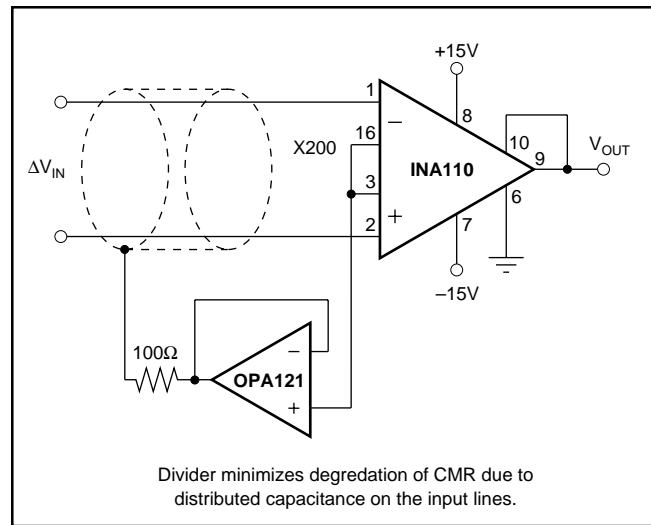

FIGURE 8. Instrumentation Amplifier with Shield Driver.

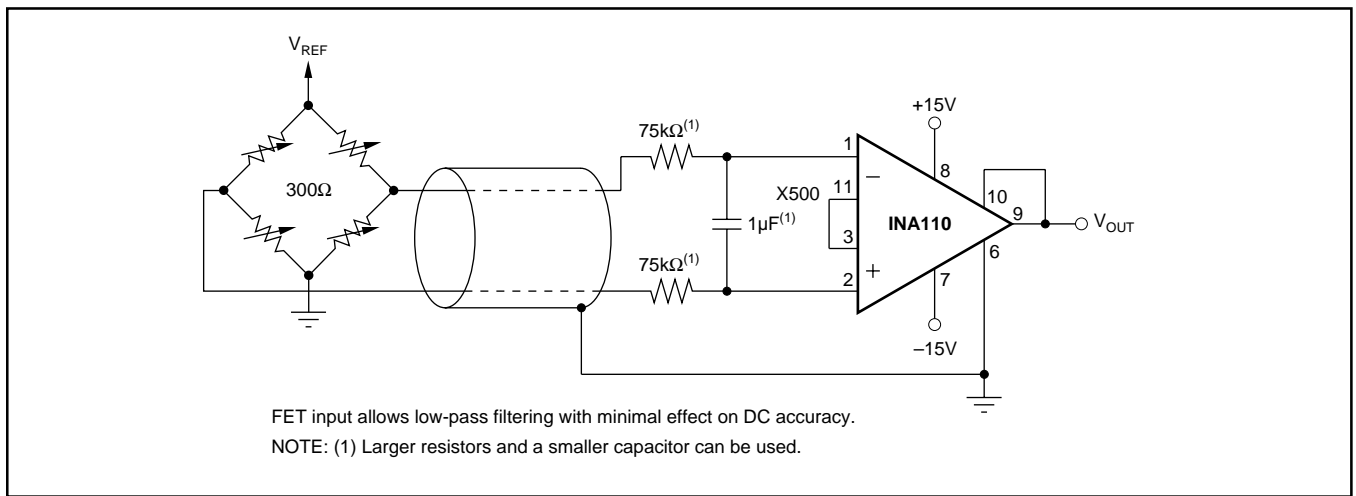

FIGURE 9. Bridge Amplifier with 1Hz Low-Pass Input Filter.

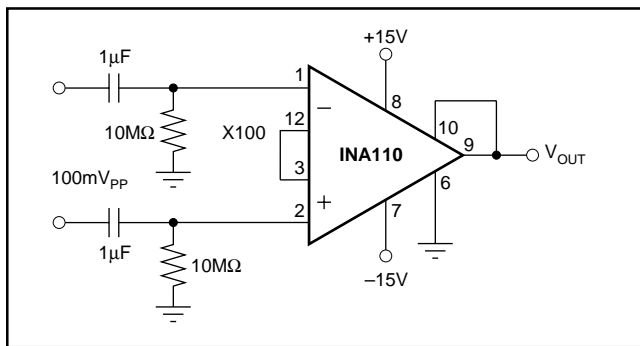

FIGURE 10. AC-Coupled Differential Amplifier for Frequencies Greater Than 0.016Hz.

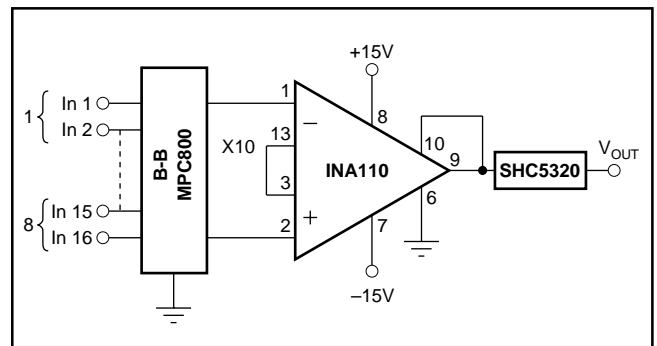

FIGURE 12. Rapid-Scanning-Rate Data Acquisition Channel with 5μs Settling to 0.01%.

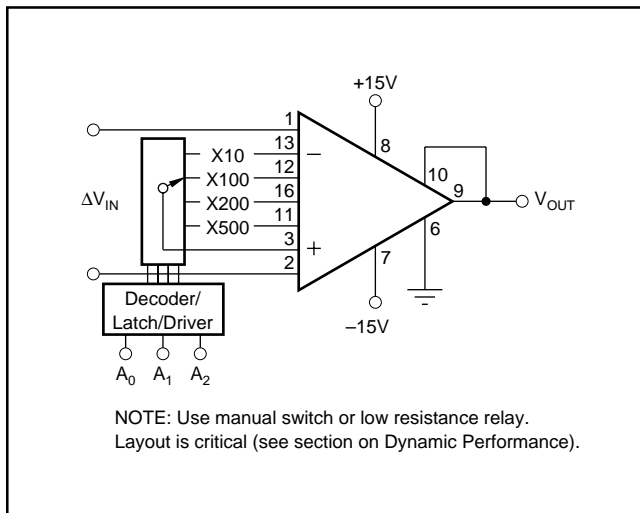

FIGURE 11. Programmable-Gain Instrumentation Amplifier (Precision Noninverting or Inverting Buffer with Gain).

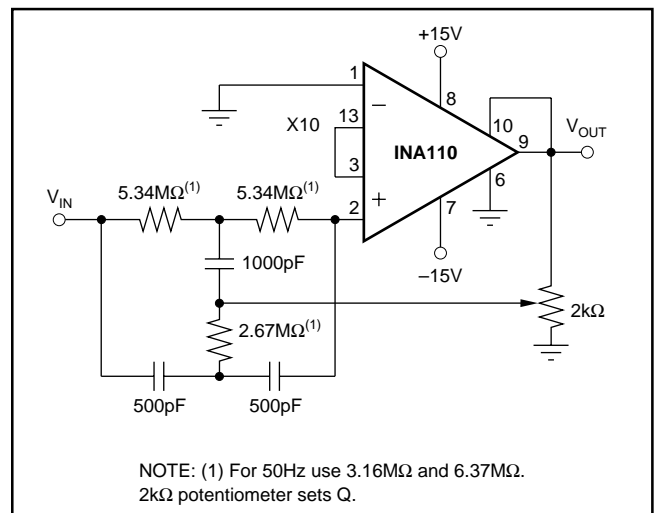

FIGURE 13. 60Hz Input Notch Filter.

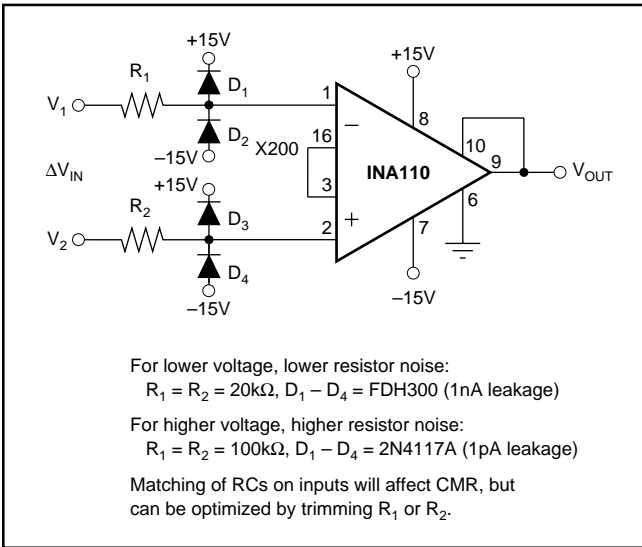

FIGURE 14. Input-Protected Instrumentation Amplifier.

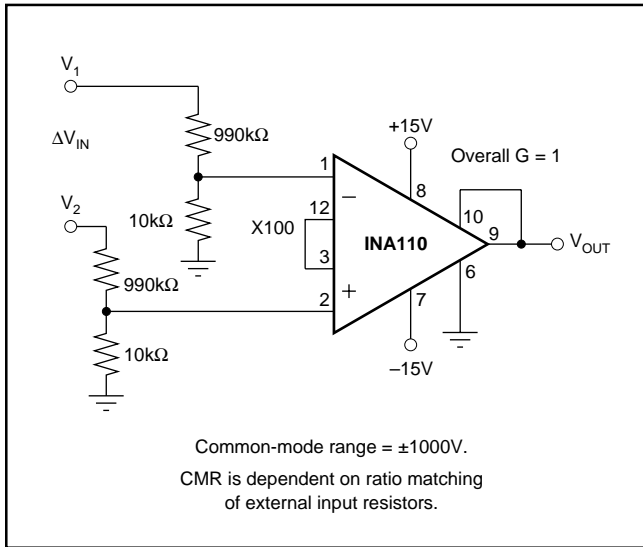

FIGURE 15. High Common-Mode Voltage Differential Amplifier.

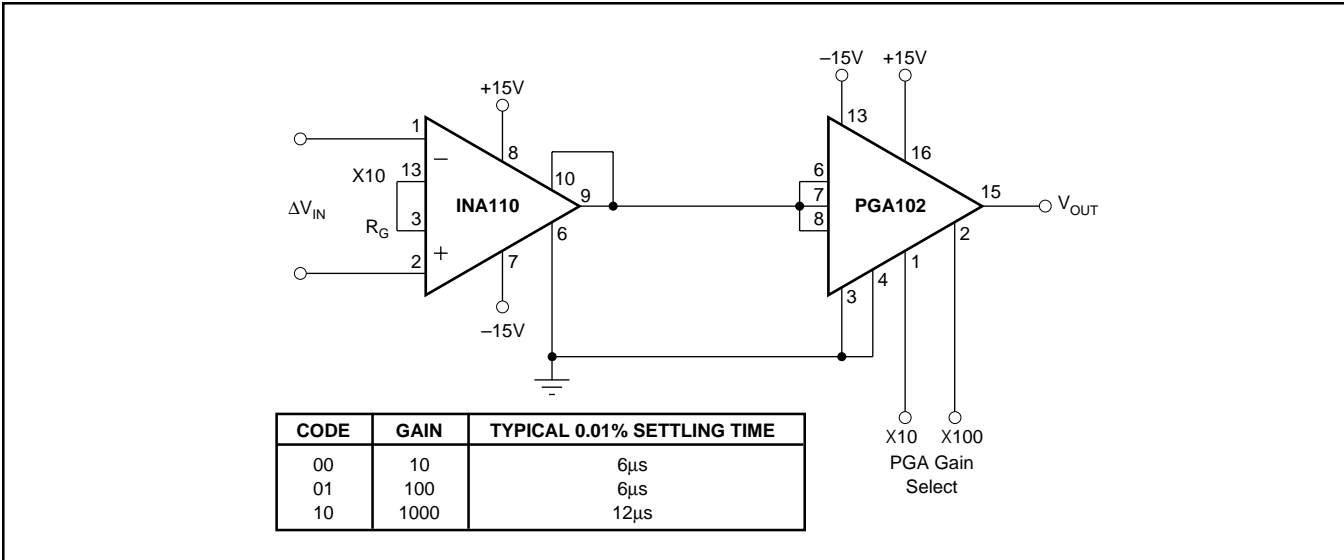

FIGURE 16. Digitally-Controlled Fast-Settling Programmable Gain Instrumentation Amplifier.

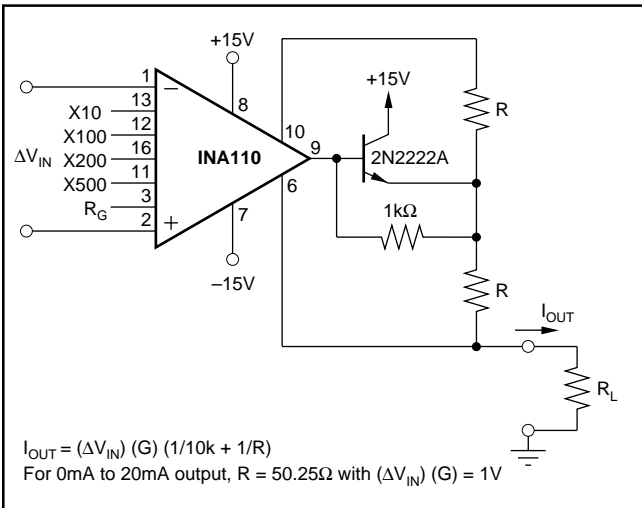

FIGURE 17. Differential Input FET Buffered Current Source.

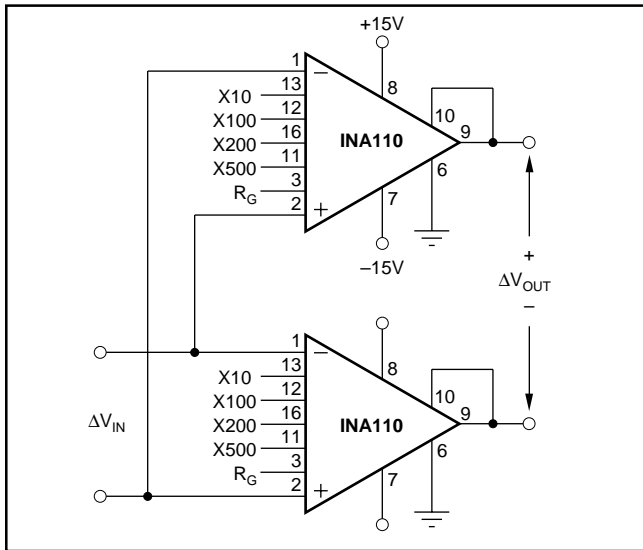

FIGURE 18. Differential Input/Differential Output Amplifier.

PACKAGING INFORMATION

Orderable Device	Status ⁽¹⁾	Package Type	Package Drawing	Pins	Package Qty	Eco Plan ⁽²⁾	Lead/ Ball Finish	MSL Peak Temp ⁽³⁾	Samples (Requires Login)
INA110AG	NRND	ZZ (BB)	ZZ109	16		TBD	Call TI	Call TI	Replaced by INA110KP
INA110KP	ACTIVE	PDIP	N	16	25	Green (RoHS & no Sb/Br)	CU NIPDAU	N / A for Pkg Type	Contact TI Distributor or Sales Office
INA110KPG4	ACTIVE	PDIP	N	16	25	Green (RoHS & no Sb/Br)	CU NIPDAU	N / A for Pkg Type	Contact TI Distributor or Sales Office
INA110KU	ACTIVE	SOIC	DW	16	40	Green (RoHS & no Sb/Br)	CU NIPDAU	Level-3-260C-168 HR	Contact TI Distributor or Sales Office
INA110KUG4	ACTIVE	SOIC	DW	16	40	Green (RoHS & no Sb/Br)	CU NIPDAU	Level-3-260C-168 HR	Contact TI Distributor or Sales Office
INA110SG	NRND	CDIP SB	JD	16	1	Green (RoHS & no Sb/Br)	AU	N / A for Pkg Type	Samples Not Available
INA110SG1	OBSOLETE	TO-100	LME	10		TBD	Call TI	Call TI	Samples Not Available
INA110SG2	OBSOLETE	TO-100	LME	10		TBD	Call TI	Call TI	Samples Not Available

⁽¹⁾ The marketing status values are defined as follows:

ACTIVE: Product device recommended for new designs.

LIFEBUY: TI has announced that the device will be discontinued, and a lifetime-buy period is in effect.

NRND: Not recommended for new designs. Device is in production to support existing customers, but TI does not recommend using this part in a new design.

PREVIEW: Device has been announced but is not in production. Samples may or may not be available.

OBSOLETE: TI has discontinued the production of the device.

⁽²⁾ Eco Plan - The planned eco-friendly classification: Pb-Free (RoHS), Pb-Free (RoHS Exempt), or Green (RoHS & no Sb/Br) - please check <http://www.ti.com/productcontent> for the latest availability information and additional product content details.

TBD: The Pb-Free/Green conversion plan has not been defined.

Pb-Free (RoHS): TI's terms "Lead-Free" or "Pb-Free" mean semiconductor products that are compatible with the current RoHS requirements for all 6 substances, including the requirement that lead not exceed 0.1% by weight in homogeneous materials. Where designed to be soldered at high temperatures, TI Pb-Free products are suitable for use in specified lead-free processes.

Pb-Free (RoHS Exempt): This component has a RoHS exemption for either 1) lead-based flip-chip solder bumps used between the die and package, or 2) lead-based die adhesive used between the die and leadframe. The component is otherwise considered Pb-Free (RoHS compatible) as defined above.

Green (RoHS & no Sb/Br): TI defines "Green" to mean Pb-Free (RoHS compatible), and free of Bromine (Br) and Antimony (Sb) based flame retardants (Br or Sb do not exceed 0.1% by weight in homogeneous material)

⁽³⁾ MSL, Peak Temp. -- The Moisture Sensitivity Level rating according to the JEDEC industry standard classifications, and peak solder temperature.

Important Information and Disclaimer: The information provided on this page represents TI's knowledge and belief as of the date that it is provided. TI bases its knowledge and belief on information provided by third parties, and makes no representation or warranty as to the accuracy of such information. Efforts are underway to better integrate information from third parties. TI has taken and

continues to take reasonable steps to provide representative and accurate information but may not have conducted destructive testing or chemical analysis on incoming materials and chemicals. TI and TI suppliers consider certain information to be proprietary, and thus CAS numbers and other limited information may not be available for release.

In no event shall TI's liability arising out of such information exceed the total purchase price of the TI part(s) at issue in this document sold by TI to Customer on an annual basis.

JD (R-CDIP-T**)

CERAMIC SIDE-BRAZE DUAL-IN-LINE PACKAGE

20 PINS SHOWN

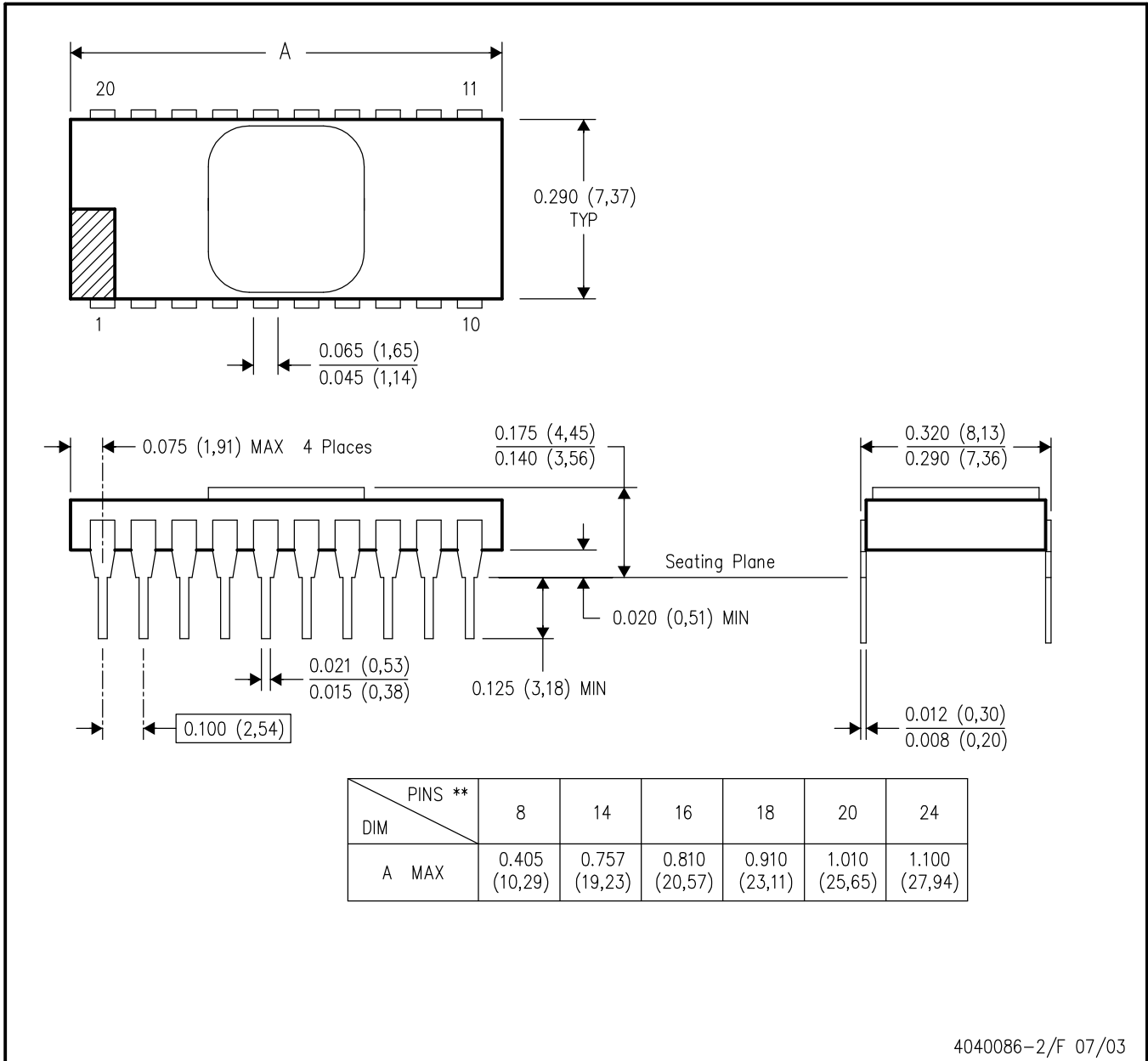

- NOTES:
- A. All linear dimensions are in inches (millimeters).
 - B. This drawing is subject to change without notice.
 - C. This package is hermetically sealed with a metal lid.
 - D. The terminals are gold plated.
 - E. Falls within MIL STD 1835 CDIP2 - T8, T14, T16, T18, T20 and T24 respectively.

Package Number 109 - 16-Lead, Ceramic Side Braze DIP, .300 Wide

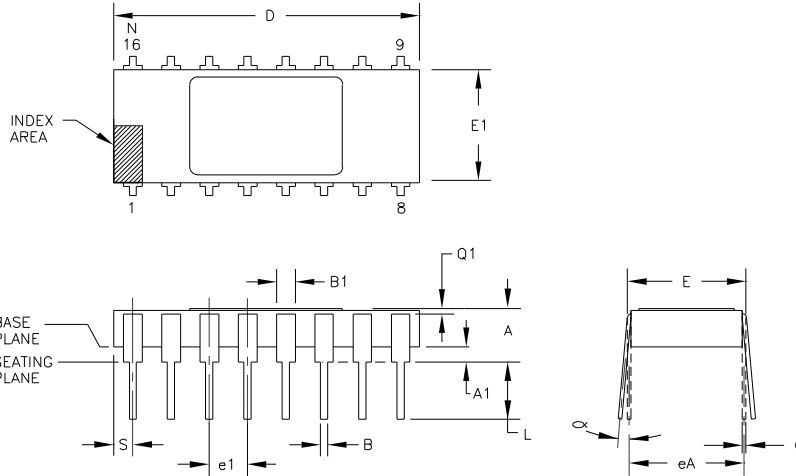

DIM	INCHES		MILLIMETERS		NO. OF LEADS	DIM	INCHES		MILLIMETERS		NO. OF LEADS
	MIN.	MAX.	MIN.	MAX.			MIN.	MAX.	MIN.	MAX.	
A	.105	.175	2.67	4.45		∞	0'	15'	0'	15'	3
A1	.025	.055	0.64	1.40							
B	.015	.021	0.38	0.53	5						
B1	.038	.060	0.97	1.52	5						
C	.008	.012	0.20	0.30							
D	.770	.830	19.56	21.08							
E	.290	.325	7.37	8.26							
E1	.280	.310	7.11	7.87	6						
e1	.100 TYP.		2.54 TYP.		2						
eA	.300 TYP.		7.62 TYP.		2						
L	.125	.175	3.18	4.45							
N	16		16		4						
Q1	.010	--	0.25	--							
S	.020	.065	0.51	1.65							

NOTES:

1. DIMENSIONING AND TOLERANCING PER ANSI Y14.5-1973.
2. LEADS WITHIN .005 IN. (0.13mm) RADIUS OF TRUE POSITION (TP) AT GAUGE PLANE WITH MAXIMUM MATERIAL CONDITION AND UNIT INSTALLED.
3. ∞ APPLIES TO SPREAD LEADS PRIOR TO INSTALLATION.
4. N IS THE NUMBER OF TERMINAL POSITIONS.

5. OUTLINES ON WHICH THE SEATING PLANE IS COINCIDENT WITH THE PLANE (A1 = 0), TERMINALS LEAD STANDOFFS ARE NOT REQUIRED, AND B1 MAY EQUAL B ALONG ANY PART OF THE LEAD ABOVE THE SEATING/BASE PLANE.
6. E1 DOES NOT INCLUDE PARTICLES OF PACKING MATERIALS.
7. CONTROLLING DIMENSION: INCH.
8. A VISUAL INDEX FEATURE MUST BE LOCATED WITHIN THE CROSS-HATCHED AREA.

PACKAGE NUMBER: ZZ109 REV.: D
JEDEC NUMBER: MO-36-AD



PACKAGE DRAWING

LME (O-MBCY-W10)

METAL CYLINDRICAL PACKAGE

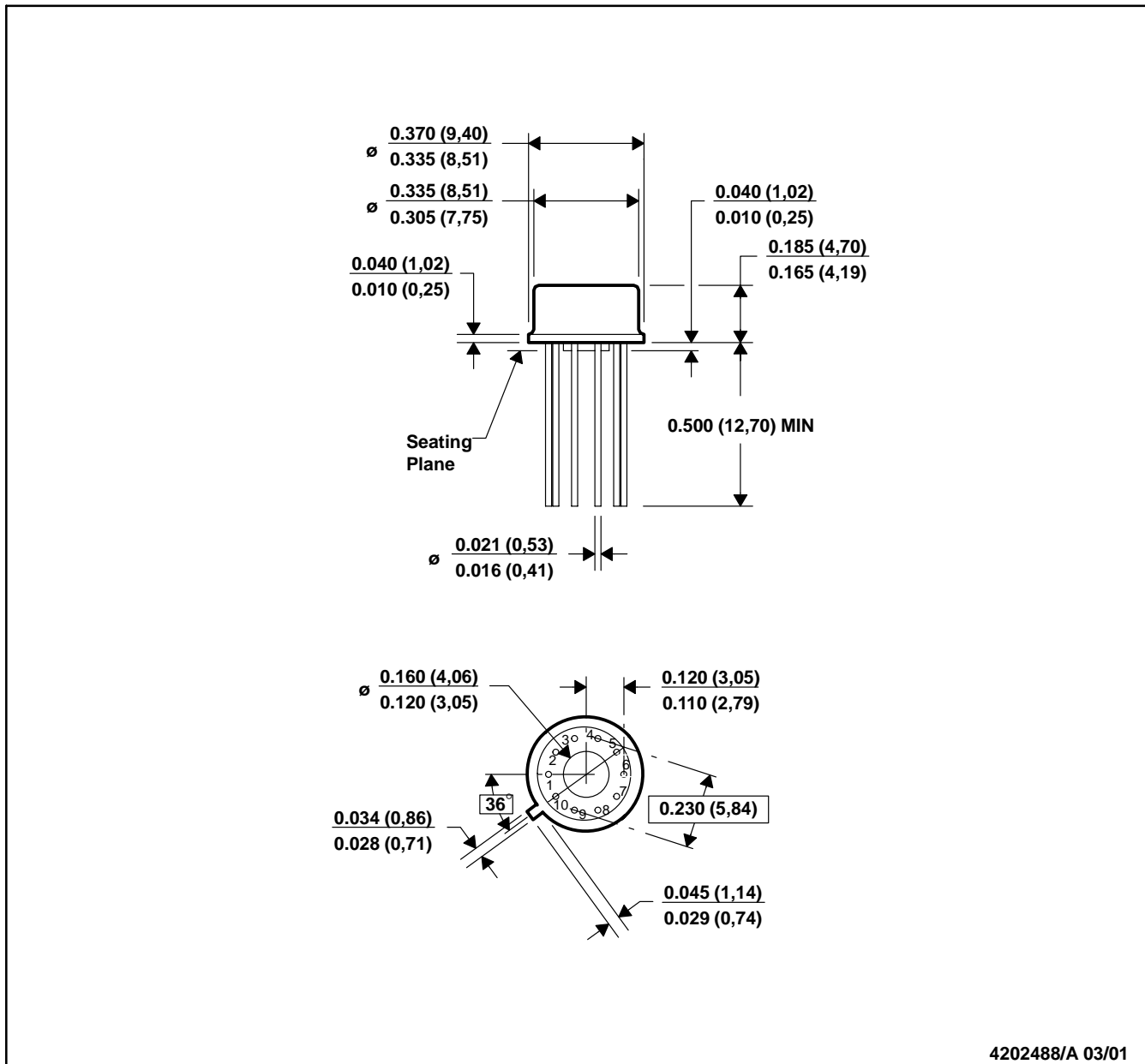

- NOTES: A. All linear dimensions are in inches (millimeters).
 B. This drawing is subject to change without notice.
 C. Leads in true position within 0.010 (0,25) R @ MMC at seating plane.
 D. Pin numbers shown for reference only. Numbers may not be marked on package.
 E. Falls within JEDEC MO-006/TO-100.

DW (R-PDSO-G16)

PLASTIC SMALL OUTLINE



- NOTES:
- All linear dimensions are in inches (millimeters). Dimensioning and tolerancing per ASME Y14.5M-1994.
 - This drawing is subject to change without notice.
 - Body dimensions do not include mold flash or protrusion not to exceed 0.006 (0,15).
 - Falls within JEDEC MS-013 variation AA.

DW (R-PDSO-G16)

PLASTIC SMALL OUTLINE

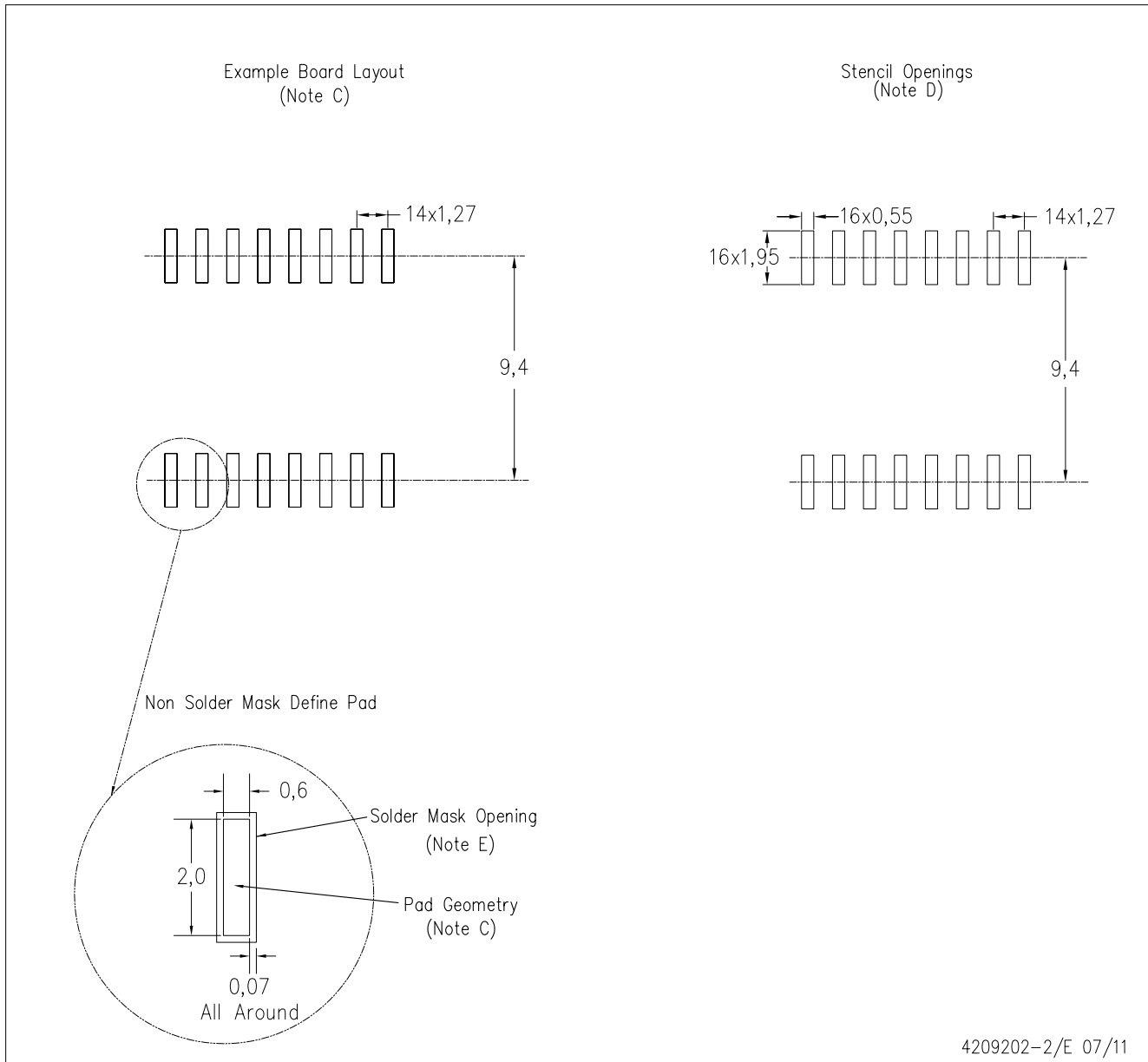

4209202-2/E 07/11

- NOTES:
- A. All linear dimensions are in millimeters.
 - B. This drawing is subject to change without notice.
 - C. Refer to IPC7351 for alternate board design.
 - D. Laser cutting apertures with trapezoidal walls and also rounding corners will offer better paste release. Customers should contact their board assembly site for stencil design recommendations. Refer to IPC-7525
 - E. Customers should contact their board fabrication site for solder mask tolerances between and around signal pads.

IMPORTANT NOTICE

Texas Instruments Incorporated and its subsidiaries (TI) reserve the right to make corrections, enhancements, improvements and other changes to its semiconductor products and services per JESD46, latest issue, and to discontinue any product or service per JESD48, latest issue. Buyers should obtain the latest relevant information before placing orders and should verify that such information is current and complete. All semiconductor products (also referred to herein as "components") are sold subject to TI's terms and conditions of sale supplied at the time of order acknowledgment.

TI warrants performance of its components to the specifications applicable at the time of sale, in accordance with the warranty in TI's terms and conditions of sale of semiconductor products. Testing and other quality control techniques are used to the extent TI deems necessary to support this warranty. Except where mandated by applicable law, testing of all parameters of each component is not necessarily performed.

TI assumes no liability for applications assistance or the design of Buyers' products. Buyers are responsible for their products and applications using TI components. To minimize the risks associated with Buyers' products and applications, Buyers should provide adequate design and operating safeguards.

TI does not warrant or represent that any license, either express or implied, is granted under any patent right, copyright, mask work right, or other intellectual property right relating to any combination, machine, or process in which TI components or services are used. Information published by TI regarding third-party products or services does not constitute a license to use such products or services or a warranty or endorsement thereof. Use of such information may require a license from a third party under the patents or other intellectual property of the third party, or a license from TI under the patents or other intellectual property of TI.

Reproduction of significant portions of TI information in TI data books or data sheets is permissible only if reproduction is without alteration and is accompanied by all associated warranties, conditions, limitations, and notices. TI is not responsible or liable for such altered documentation. Information of third parties may be subject to additional restrictions.

Resale of TI components or services with statements different from or beyond the parameters stated by TI for that component or service voids all express and any implied warranties for the associated TI component or service and is an unfair and deceptive business practice. TI is not responsible or liable for any such statements.

Buyer acknowledges and agrees that it is solely responsible for compliance with all legal, regulatory and safety-related requirements concerning its products, and any use of TI components in its applications, notwithstanding any applications-related information or support that may be provided by TI. Buyer represents and agrees that it has all the necessary expertise to create and implement safeguards which anticipate dangerous consequences of failures, monitor failures and their consequences, lessen the likelihood of failures that might cause harm and take appropriate remedial actions. Buyer will fully indemnify TI and its representatives against any damages arising out of the use of any TI components in safety-critical applications.

In some cases, TI components may be promoted specifically to facilitate safety-related applications. With such components, TI's goal is to help enable customers to design and create their own end-product solutions that meet applicable functional safety standards and requirements. Nonetheless, such components are subject to these terms.

No TI components are authorized for use in FDA Class III (or similar life-critical medical equipment) unless authorized officers of the parties have executed a special agreement specifically governing such use.

Only those TI components which TI has specifically designated as military grade or "enhanced plastic" are designed and intended for use in military/aerospace applications or environments. Buyer acknowledges and agrees that any military or aerospace use of TI components which have **not** been so designated is solely at the Buyer's risk, and that Buyer is solely responsible for compliance with all legal and regulatory requirements in connection with such use.

TI has specifically designated certain components as meeting ISO/TS16949 requirements, mainly for automotive use. In any case of use of non-designated products, TI will not be responsible for any failure to meet ISO/TS16949.

Products

Audio	www.ti.com/audio
Amplifiers	amplifier.ti.com
Data Converters	dataconverter.ti.com
DLP® Products	www.dlp.com
DSP	dsp.ti.com
Clocks and Timers	www.ti.com/clocks
Interface	interface.ti.com
Logic	logic.ti.com
Power Mgmt	power.ti.com
Microcontrollers	microcontroller.ti.com
RFID	www.ti-rfid.com
OMAP Applications Processors	www.ti.com/omap
Wireless Connectivity	www.ti.com/wirelessconnectivity

Applications

Automotive and Transportation	www.ti.com/automotive
Communications and Telecom	www.ti.com/communications
Computers and Peripherals	www.ti.com/computers
Consumer Electronics	www.ti.com/consumer-apps
Energy and Lighting	www.ti.com/energy
Industrial	www.ti.com/industrial
Medical	www.ti.com/medical
Security	www.ti.com/security
Space, Avionics and Defense	www.ti.com/space-avionics-defense
Video and Imaging	www.ti.com/video

TI E2E Community

e2e.ti.com