

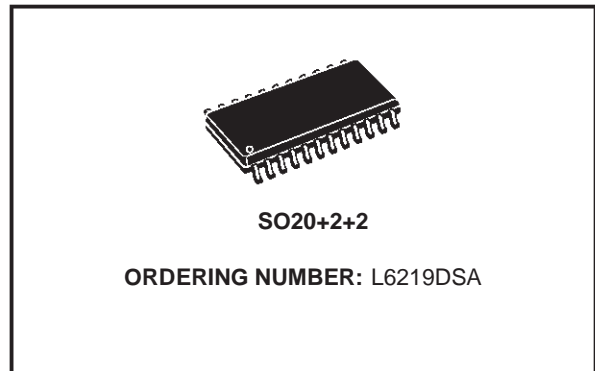

# L6219DSA

## STEPPER MOTOR DRIVER FOR AUTOMOTIVE RANGE

- ABLE TO DRIVE BOTH WINDINGS OF BIPO-LAR STEPPER MOTOR
- OUTPUT CURRENT UP TO 750mA EACH WINDING
- WIDE VOLTAGE RANGE 10V TO 46V
- HALF-STEP, FULL-STEP AND MICROSTEPP-ING MODE
- BUILT-IN PROTECTION DIODES
- INTERNAL PWM CURRENT CONTROL
- LOW OUTPUT SATURATION VOLTAGE
- DESIGNED FOR UNSTABILIZED MOTOR SUPPLY VOLTAGE
- INTERNAL THERMAL SHUTDOWN



### DESCRIPTION

The L6219DSA is a bipolar monolithic integrated circuits intended to control and drive both winding of a bipolar stepper motor or bidirectionally control two DC motors.

The L6219DSA with a few external components form a complete control and drive circuit for LS-TTL or microprocessor controlled stepper motor system.

The power stage is a dual full bridge capable of sustaining 46V and including four diodes for current recirculation.

A cross conduction protection is provided to avoid simultaneous cross conduction during switching current direction.

An internal pulse-width-modulation (PWM) controls the output current to 750mA with peak start-up current up to 1A.

Wide range of current control from 750mA (each bridge) is permitted by means of two logic inputs and an external voltage reference. A phase input to each bridge determines the load current direction.

A thermal protection circuitry disables the outputs if the chip temperature exceeds safe operating limits.

### BLOCK DIAGRAM

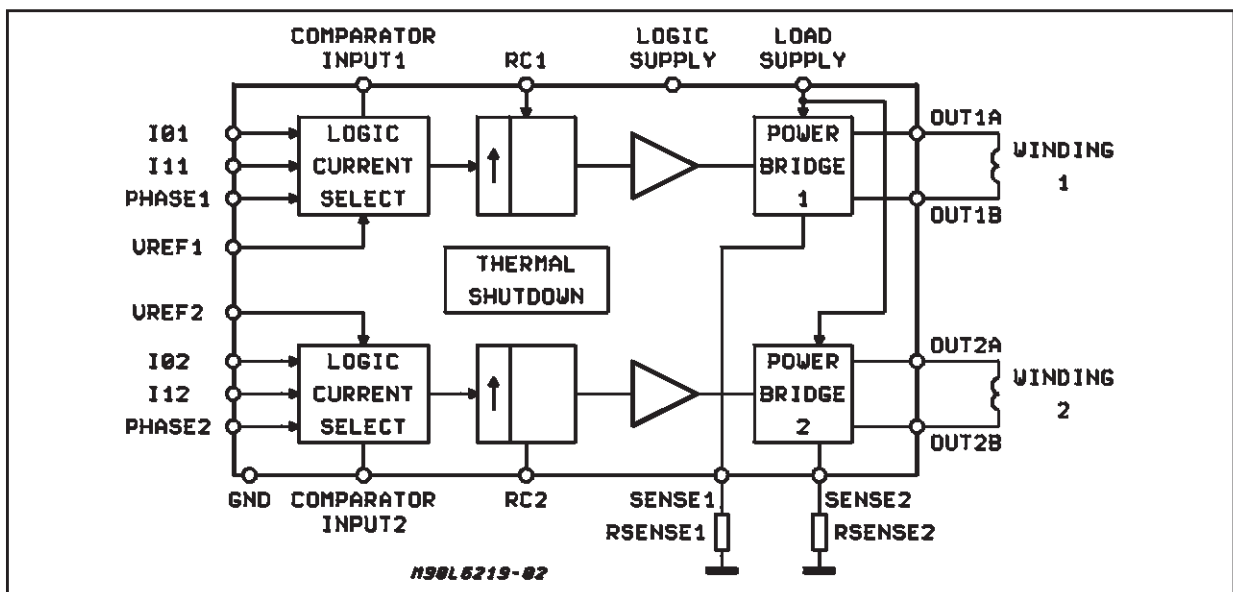

## L6219DSA

### PIN CONNECTION (Top view)

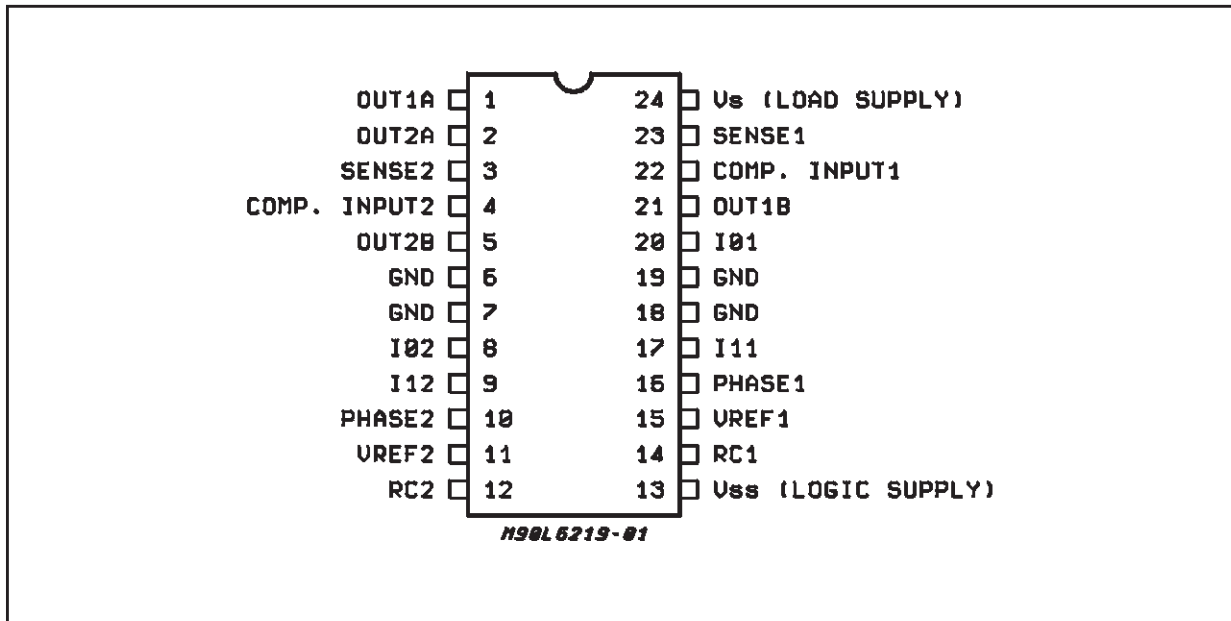

### PIN FUNCTIONS

N°	Name	Function
1;2	OUTPUT A	See pins 5;21
3;23	SENSE RESISTOR	Connection to Lower Emitters of Output Stage for Insertion of Current Sense Resistor
4;22	COMPARATOR INPUT	Input connected to the comparators. The voltage across the sense resistor is feedback to this input through the low pass filter RC CC. The higher power transistors are disabled when the sense voltage exceeds the reference voltage of the selected comparator. When this occurs the current decays for a time set by $R_T C_T$ ( $t_{off} = 1.1 R_T C_T$ ). See fig. 1.
5;21	OUTPUT B	Output Connection. The output stage is a "H" bridge formed by four transistors and four diodes suitable for switching applications.
6;19	GROUND	See pins 7;18
7;18	GROUND	Ground Connection. With pins 6 and 19 also conducts heat from die to printed circuit copper.
8;20	INPUT 0	See INPUT 1 (pins 9;17)
9;17	INPUT 1	These pins and pins 8;20 (INPUT 0) are logic inputs which select the outputs of the comparators to set the current level. Current also depends on the sensing resistor and reference voltage. See Funcional Description.
10;16	PHASE	This TTL-compatible logic inputs sets the direction of current flow through the load. A high level causes current to flow from OUTPUT A (source) to OUTPUT B (sink). A schmitt trigger on this input provides good noise immunity and a delay circuit prevents output stage short circuits during switching.
11;15	REFERENCE VOLTAGE	A voltage applied to this pin sets the reference voltage of the comparators, this determining the output current (also thus depending on $R_s$ and the two inputs INPUT 0 and INPUT 1).
12;14	RC	A parallel RC network connected to this pin sets the OFF time of the higher power transistors. The pulse generator is a monostable triggered by the output of the comparators ( $t_{off} = 1.1 R_T C_T$ ).
13	$V_{ss}$ - LOGIC SUPPLY	Supply Voltage Input for Logic Circuitry
24	$V_s$ - LOAD SUPPLY	Supply Voltage Input for the Output Stages.

**Note:** ESD on GND,  $V_s$ ,  $V_{ss}$ , OUT 1A and OUT 2A is guaranteed up to 1.5KV (Human Body Model, 1500 $\Omega$ , 100pF).

## ABSOLUTE MAXIMUM RATINGS

Symbol	Parameter	Value	Unit
$V_S$	Supply Voltage	50	V
$I_o$	Output Current (peak)	$\pm 1$	A
$I_o$	Output Current (continuous)	$\pm 0.75$	A
$V_{SS}$	Logic Supply Voltage	7	V
$V_{IN}$	Logic Input Voltage Range	-0.3 to +7	V
$V_{sense}$	Sense Output Voltage	1.5	V
$T_J$	Junction Temperature	+150	°C
$T_{Op}$	Operating Temperature Range	-40 to 125	°C
$T_{stg}$	Storage Temperature Range	-55 to +150	°C

## THERMAL DATA

Symbol	Description	Value	Unit
$R_{thj-case}$	Thermal Resistance Junction-case	Max. 18	°C/W
$R_{thj-amb}$	Thermal Resistance Junction-ambient	Max. 75 (*)	°C/W

(\*) With minimized copper area.

**ELECTRICAL CHARACTERISTICS** ( $T_j = -40$  to  $125^\circ\text{C}$ ,  $V_S = 46\text{V}$ ,  $V_{SS} = 4.75\text{V}$  to  $5.25\text{V}$ ,  $V_{REF} = 5\text{V}$ ; unless otherwise specified) See fig. 3.

Symbol	Parameter	Test Condition	Min.	Typ.	Max.	Unit
--------	-----------	----------------	------	------	------	------

OUTPUT DRIVERS (OUT<sub>A</sub> or OUT<sub>B</sub>)

$V_S$	Motor Supply Range		10		46	V
$I_{CEX}$	Output Leakage Current	$V_S = 52\text{V}$ $V_{OUT} = 50\text{V}$ $V_S = 52\text{V}$ $V_{OUT} = 1\text{V}$	-200		200	$\mu\text{A}$ $\mu\text{A}$
$V_{CE(sat)}$	Output Saturation Voltage	Sink Driver, $I_{OUT} = +500\text{mA}$ Sink Driver, $I_{OUT} = +750\text{mA}$ Source Driver, $I_{OUT} = -500\text{mA}$ Source Driver, $I_{OUT} = -750\text{mA}$			0.75 1.15 1.6 1.8	V V V V
$V_F$	Clamp Diode Forward Voltage	High stage $I_F = 750\text{mA}$ Low stage $I_F = 750\text{mA}$			1.7 1.6	V V
$I_{S(on)}$	Driver Supply Current	Both Bridges ON, No Load			17	mA
$I_{S(off)}$	Driver Supply Current	Both Bridges OFF			12	mA

## CONTROL LOGIC

$V_{IN(H)}$	Input Voltage	All Inputs	2.4			V
$V_{IN(L)}$	Input Voltage	All Inputs			0.8	V
$I_{IN(H)}$	Input Current	$V_{IN} = 2.4\text{V}$		<1	20	$\mu\text{A}$
$I_{IN(L)}$	Input Current	$V_{IN} = 0.84\text{V}$		-3	-200	$\mu\text{A}$
$V_{REF}$	Reference Voltage	Operating	1.5		7.5	V
$I_{SS(ON)}$	Total Logic Supply Current	$I_o = I_1 = 0.8\text{V}$ , No Load			76	mA
$I_{SS(OFF)}$	Total Logic Supply Current	$I_o = I_1 = 2.4\text{V}$ , No Load			15	mA

## COMPARATORS

$V_{REF} / V_{sense}$	Current Limit Threshold (at trip point)	$I_o = I_1 = 0.8\text{V}$	9.5	10	10.5	
		$I_o = 2.4\text{V}$ , $I_1 = 0.8\text{V}$	13.5	15	16.5	
		$I_o = 0.8\text{V}$ , $I_1 = 2.4\text{V}$	25.5	30	34.5	
$t_{off}$	Cutoff Time	$R_t = 56\text{K}\Omega$ $C_t = 820\text{pF}$		50		$\mu\text{s}$
$t_d$	Turn Off Delay	Fig. 1		1		$\mu\text{s}$

**ELECTRICAL CHARACTERISTICS** (Continued)

Symbol	Parameter	Test Condition	Min.	Typ.	Max.	Unit
PROTECTION						
T <sub>J</sub>	Thermal Shutdown Temperature		-	170	-	°C

Figure 1

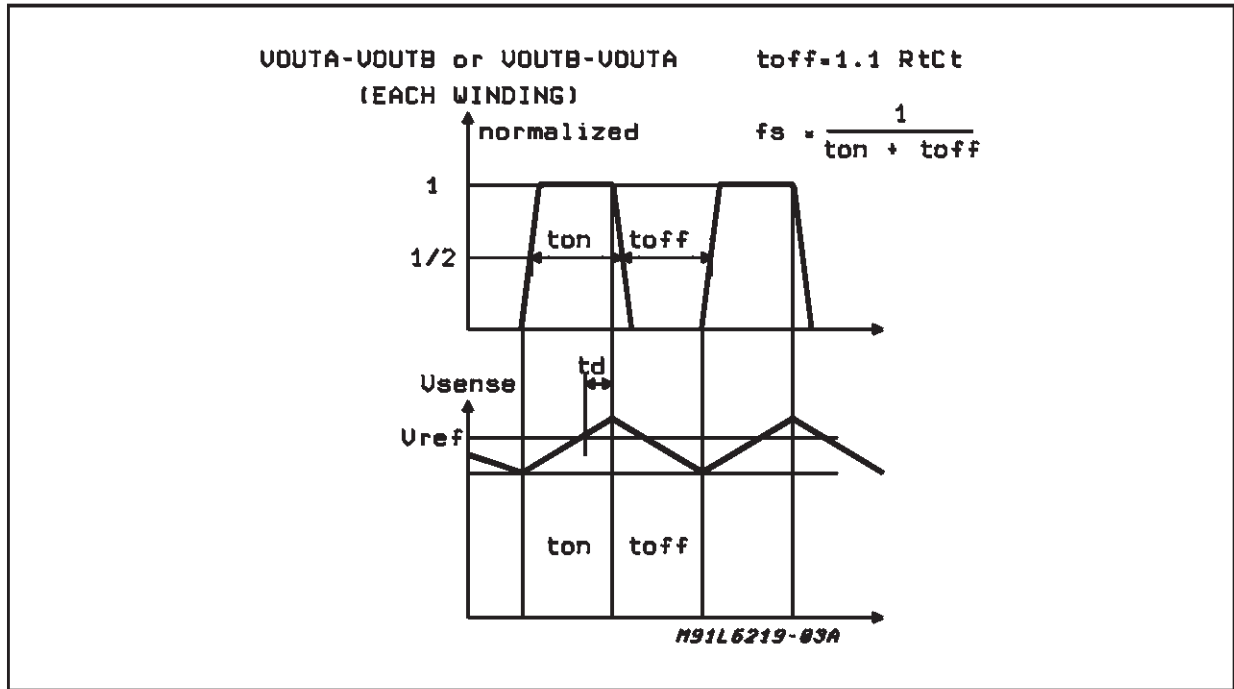

**FUNCTIONAL DESCRIPTION**

The circuit is intended to drive both windings of a bipolar stepper motor. The peak current control is generated through switch mode regulation. There is a choice of three different current levels with the two logic inputs I<sub>01</sub> - I<sub>11</sub> for winding 1 and I<sub>02</sub> - I<sub>12</sub> for winding 2. The current can also be switched off completely

**Input Logic (I<sub>0</sub> and I<sub>1</sub>)**

The current level in the motor winding is selected with these inputs. (See fig. 2) If any of the logic inputs is left open, the circuit will treat it has a high level input.

I <sub>0</sub>	I <sub>1</sub>	Current Level
H	H	No Current
L	H	Low Current 1/3 I <sub>0</sub> max
H	L	Medium Current 2/3 I <sub>0</sub> max
L	L	Maximum Current I <sub>0</sub> max

**Phase**

This input determines the direction of current flow

in the windings, depending on the motor connections. The signal is fed through a Schmidt-trigger for noise immunity, and through a time delay in order to guarantee that no short-circuit occurs in the output stage during phase-shift. High level on the PHASE input causes the motor current flow from Out A through the winding to Out B

**Current Sensor**

This part contains a current sensing resistor (R<sub>s</sub>), a low pass filter (R<sub>c</sub>, C<sub>c</sub>) and three comparators. Only one comparator is active at a time. It is activated by the input logic according to the current level chosen with signals I<sub>0</sub> and I<sub>1</sub>. The motor current flows through the sensing resistor R<sub>s</sub>. When the current has increased so that the voltage across R<sub>s</sub> becomes higher than the reference voltage on the other comparator input, the comparator goes high, which triggers the pulse generator. The max peak current I<sub>max</sub> can be defined by:

$$I_{max} = \frac{V_{ref}}{10 R_s}$$

Figure 2: Principle Operating Sequence

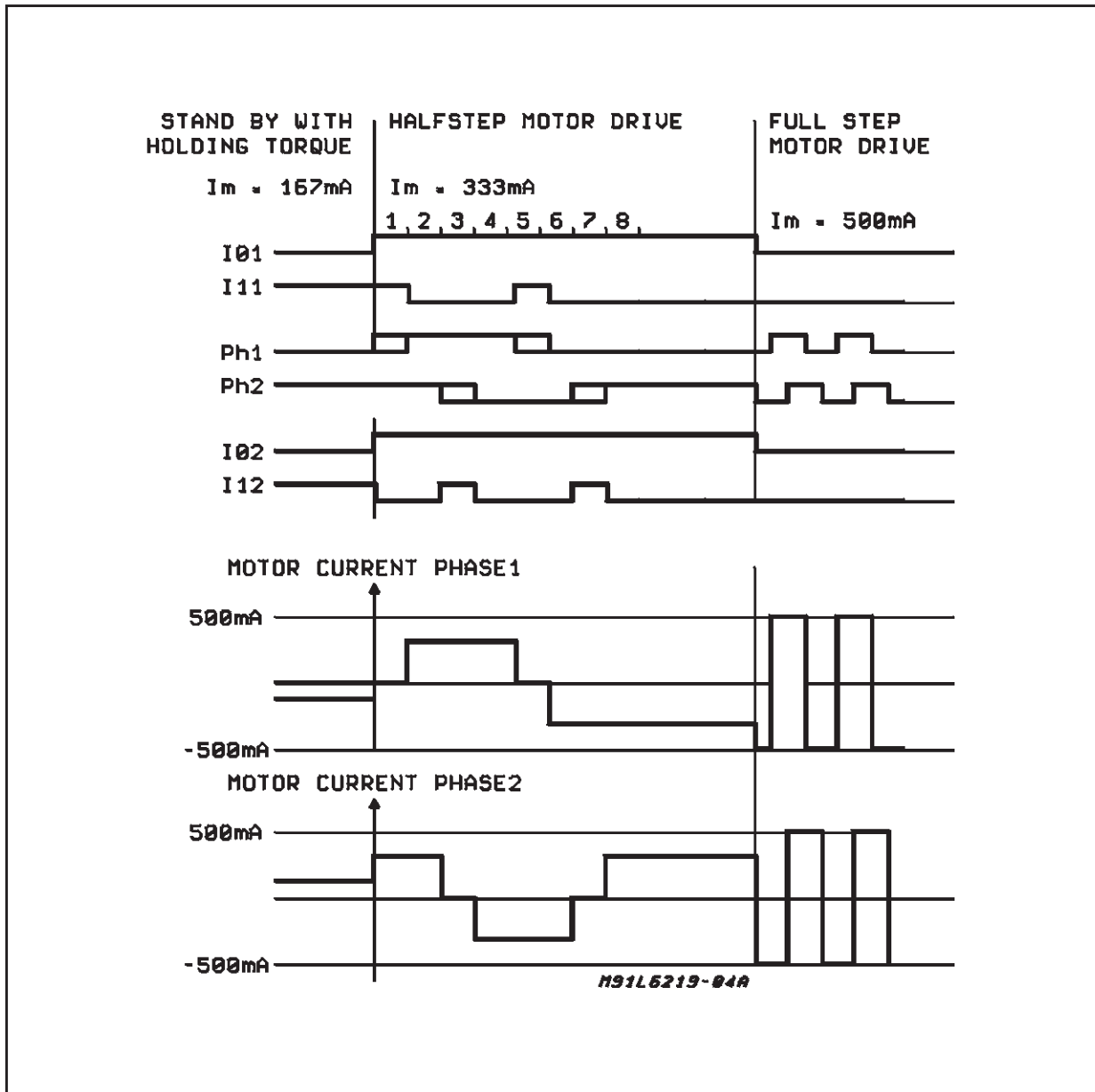

### Single-pulse Generator

The pulse generator is a monostable triggered on the positive going edge of the comparator output. The monostable output is high during the pulse time,  $t_{off}$ , which is determined by the time components  $R_t$  and  $C_t$ .

$$t_{off} = 1.1 \cdot R_t C_t$$

The single pulse switches off the power feed to the motor winding, causing the winding current to decrease during  $t_{off}$ .

If a new trigger signal should occur during  $t_{off}$ , it is ignored.

### Output Stage

The output stage contains four Darlington transistors (source drivers) four saturated transistors (sink drivers) and eight diodes, connected in two H bridge.

The source transistors are used to switch the power supplied to the motor winding, thus driving a constant current through the winding.

It should be noted however, that is not permitted to short circuit the outputs.

Internal circuitry is added in order to increase the accuracy of the motor current particularly with low current levels.

## L6219DSA

### $V_S$ , $V_{SS}$ , $V_{Ref}$

The circuit will stand any order of turn-on or turn-off the supply voltages  $V_S$  and  $V_{SS}$ . Normal  $dV/dt$  values are then assumed.

Preferably,  $V_{Ref}$  should be tracking  $V_{SS}$  during power-on and power-off if  $V_S$  is established.

### APPLICATION INFORMATIONS (Note 1)

Some stepper motors are not designed for continuous operation at maximum current. As the circuit drives a constant current through the motor, its temperature might increase exceedingly both at low and high speed operation.

Also, some stepper motors have such high core losses that they are not suited for switch mode current regulation.

Unused inputs should be connected to proper voltage levels in order to get the highest noise immunity.

As the circuit operates with switch mode current regulation, interference generation problems might arise in some applications. A good measure might then be to decouple the circuit with a 100nF capacitor, located near the package between power line and ground.

The ground lead between  $R_S$  and circuit GND should be kept as short as possible.

A typical Application Circuit is shown in Fig. 3.

Note that  $C_t$  must be NPO type or similar else.

To sense the winding current, paralleled metal film resistors are recommended ( $R_S$ )

**Note 1** - Other information is available as "Smart Power Development System":

Test board HWL6219DSA (Stepper driver)

Software SWL6219DSA (Floppy disc)

**Figure 3:** Typical Application Circuit. (Pin out referred to DIP24 package)

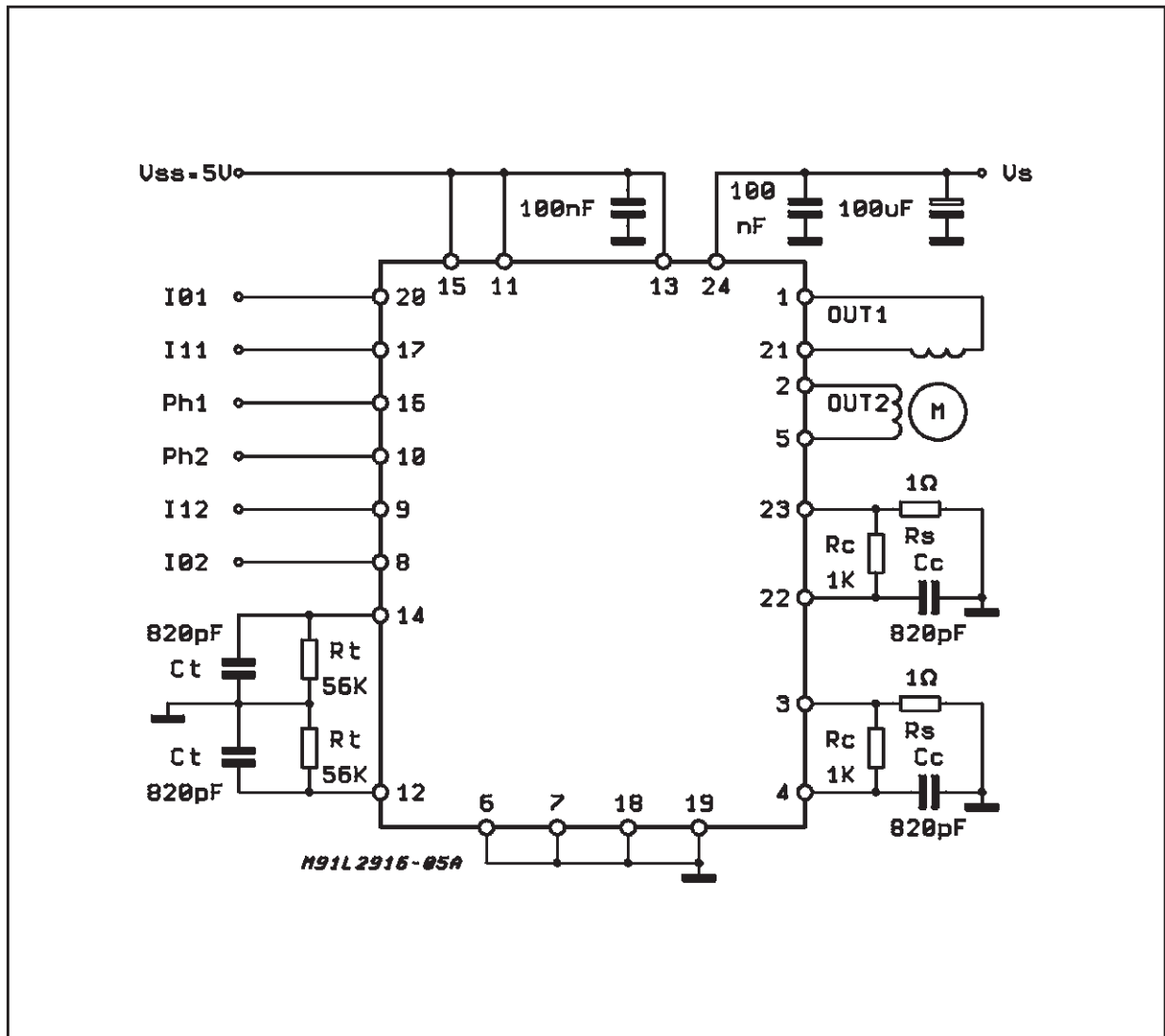

## SO24 PACKAGE MECHANICAL DATA

DIM.	mm			inch		
	MIN.	TYP.	MAX.	MIN.	TYP.	MAX.
A	2.35		2.65	0.093		0.104
A1	0.10		0.30	0.004		0.012
A2			2.55			0.100
B	0.33		0.51	0.013		0.0200
C	0.23		0.32	0.009		0.013
D	15.20		15.60	0.598		0.614
E	7.40		7.60	0.291		0.299
e		1.27			0,050	
H	10.0		10.65	0.394		0.419
h	0.25		0.75	0.010		0.030
k	0° (min.), 8° (max.)					
L	0.40		1.27	0.016		0.050

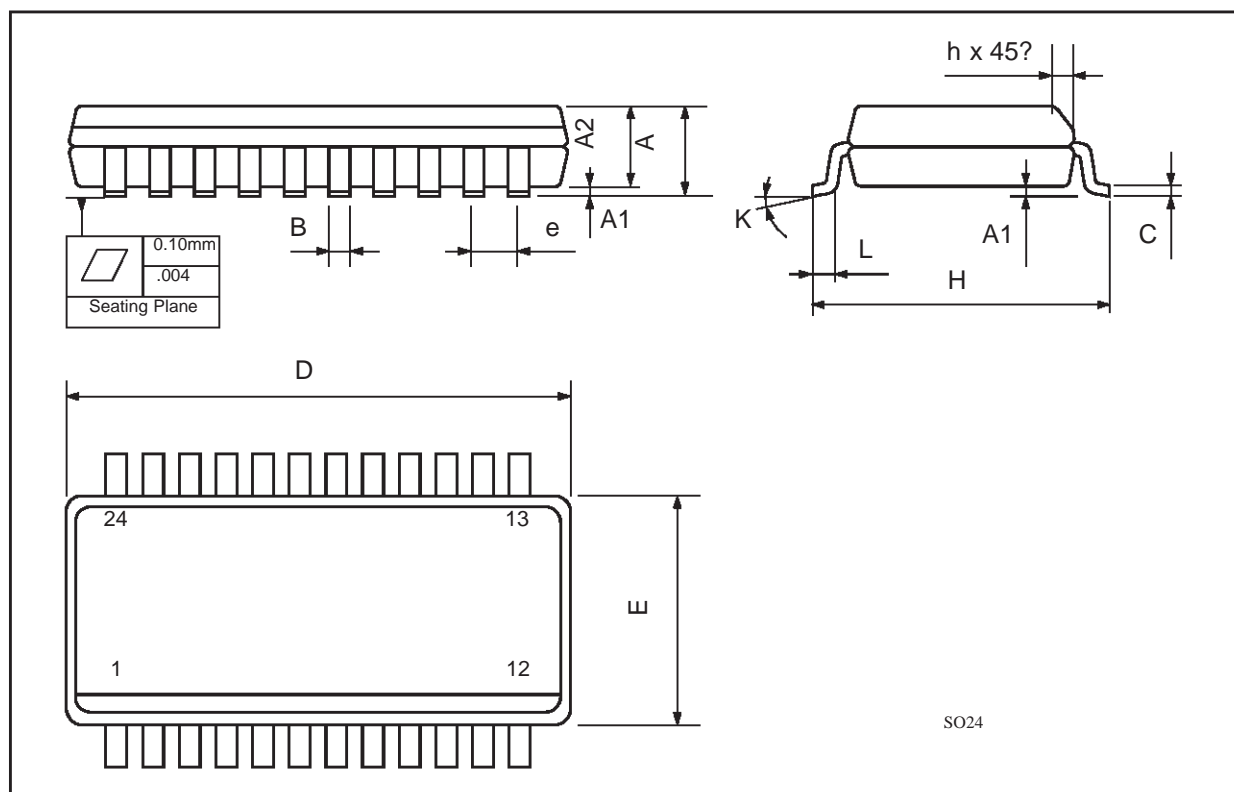

Information furnished is believed to be accurate and reliable. However, STMicroelectronics assumes no responsibility for the consequences of use of such information nor for any infringement of patents or other rights of third parties which may result from its use. No license is granted by implication or otherwise under any patent or patent rights of STMicroelectronics. Specification mentioned in this publication are subject to change without notice. This publication supersedes and replaces all information previously supplied. STMicroelectronics products are not authorized for use as critical components in life support devices or systems without express written approval of STMicroelectronics.

The ST logo is a registered trademark of STMicroelectronics

© 1998 STMicroelectronics – Printed in Italy – All Rights Reserved

STMicroelectronics GROUP OF COMPANIES

Australia - Brazil - Canada - China - France - Germany - Italy - Japan - Korea - Malaysia - Malta - Mexico - Morocco - The Netherlands - Singapore - Spain - Sweden - Switzerland - Taiwan - Thailand - United Kingdom - U.S.A.

<http://www.st.com>