

**SANYO**

No.2179A

**LA3225T,3226T**

Monolithic Linear IC

**2-CHANNEL PREAMPLIFIER WITH ALC**

The LA3225T,3226T are 2-channel low-noise preamplifiers designed for cassette tape recorder use.

The LA3225T,3226T contain preamplifiers and rectifiers in a 10-pin single-end package and require fewer number of external parts.

**Use**

- Stereo, compact cassette tape recorders (recording/playback), radio-cassette recorders (recording/playback).
- LA3225T: 6V-operated tape recorder use
- LA3226T: 9V-operated tape recorder use

**Features**

- Open loop gain 85dB typ.
- On-chip rectifiers and ALC circuit.
- Capable of operating from  $V_{CC}=3.8V$  (LA3225T),  $V_{CC}=5.5V$  (LA3226T) because of good reduced voltage characteristic
- On-chip feedback resistors ( $R_{NF}=100k\Omega$ )
- The rectifier operation can be stopped at the playback mode (ALC OFF).

**Maximum Ratings at  $T_a=25^\circ C$** 

Parameter	Symbol	Value	Unit
Maximum Supply Voltage	$V_{CC\ max}$	14.0	V
Allowable Power Dissipation	$P_d\ max$	730	mW
Operating Temperature	$T_{opg}$	-20 to +75	$^\circ C$
Storage Temperature	$T_{stg}$	-40 to +125	$^\circ C$

**Operating Conditions at  $T_a=25^\circ C$** 

Parameter	Symbol	Value	Unit
Operating Voltage Range	$V_{CC\ op}$	3.8 to 12.0	V
		5.5 to 12.0	V

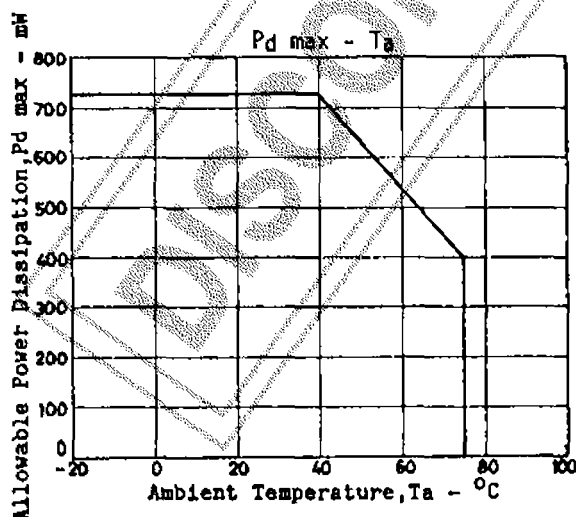

The application circuit diagrams and circuit constants herein are included as an example and provide no guarantee for designing equipment to be mass-produced. The information herein is believed to be accurate and reliable. However, no responsibility is assumed by SANYO for its use, nor for any infringements of patents or other rights of third parties which may result from its use.

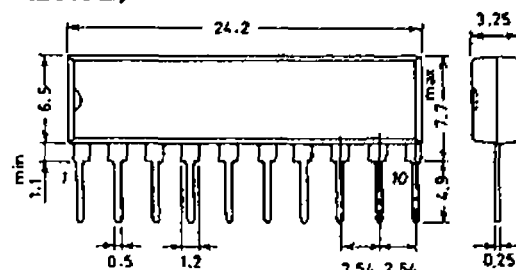
**Case Outline 3043A-S10IC (unit:mm)**

Specifications and information herein are subject to change without notice.

SANYO: SEP10

**SANYO Electric Co., Ltd. Semiconductor Overseas Marketing Div.**  
15-13, 6 chome, Sotokanda, Chiyoda-ku, TOKYO 101 JAPAN

0137KI/7036KI, TS No.2179-1/2

LA3225T.3226T

Operating Characteristics at  $T_a=25^{\circ}\text{C}$ ,  $V_{CC}=5.0\text{V}$  (LA3225T),  $V_{CC}=6.0\text{V}$  (LA3226T),  
 $R_L=10\text{kohms}$ ,  $f=1\text{kHz}$ ,  $0\text{dB}=0.775\text{V}$

			min	typ	max	unit
Quiescent Current	$I_{COO}$	$R_g=2.2\text{kohms}$		6.0	12	mA
[Amp Section]						
Voltage Gain (Open Loop)	$V_{G_O}$	$V_o=0\text{dB}$	80	85		dB
(Closed Loop)	$V_{G_R}$	$V_o=-10\text{dBm, flat}$	57	60	63	dB
	$V_{G_P}$	$V_o=-10\text{dBm, NAB}$	42	45	48	dB
Total Harmonic Distortion	THD	$V_o=0\text{dBm, NAB}$		0.15	1.0	%
Maximum Output Voltage	$V_o \text{ max}$	THD=1%	0.7	0.85		V
Equivalent Input Noise Voltage	$V_{NIR}$	$R_g=2.2\text{kohms, VG}=60\text{dB}/1\text{kHz, flat}$		1.0	2.0	$\mu\text{V}$
	$V_{NIP}$	$R_g=2.2\text{kohms, VG}=45\text{dB}/1\text{kHz, NAB}$		0.9	1.8	$\mu\text{V}$
Input Resistance	$r_i$		21	30		kohm
Channel Separation	Sep	$VG=45/1\text{kHz, NAB}$	40	51		dB
[ALC Section]						
ALC Range	ALC W	Input range for ALC output difference of +3dB, flat	35	45		dB
ALC Balance	ALC B	$V_o$ ratio of oh1/oh2 at $V_i=-50\text{dB, flat}$			2	dB
ALC Distortion	ALC THD	$V_i=-50\text{dB, flat}$		0.8	2.0	%
ALC Output Voltage	ALC $v_o$	LA3225T	0.36	0.45	0.53	V
		LA3226T	0.75	0.85	0.95	V

Equivalent Circuit Block Diagram

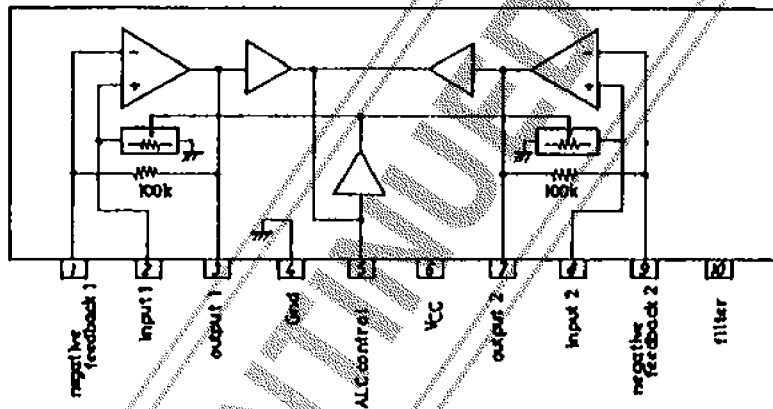

Sample Application Circuit

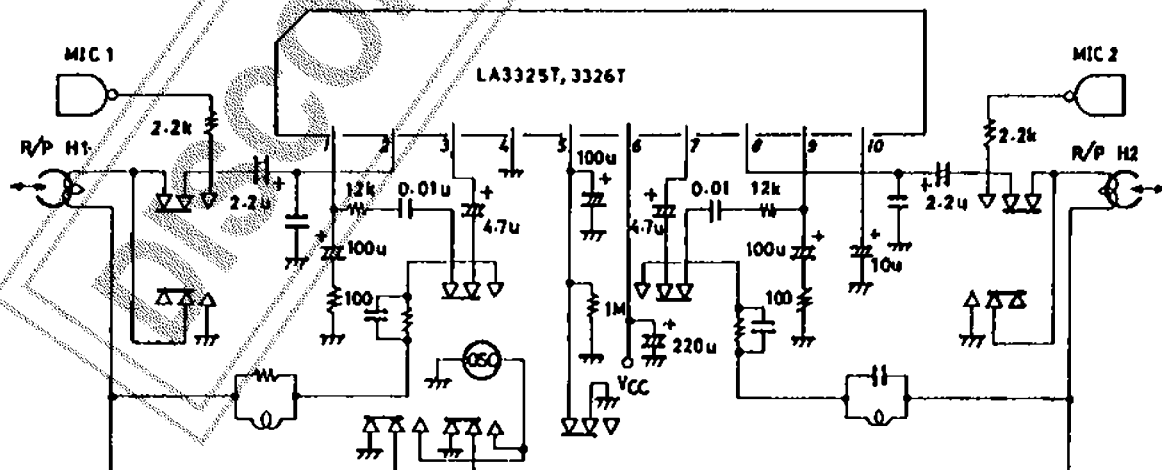

- \* : . The recording gain and playback gain are set to 60dB and 45dB respectively.
- . The input coupling capacitor for the amplifier is required to prevent the noise that may occur at the time of R/P select.