

SANYO

No. 3534

LA4571MB**Low-voltage Headphone Amplifier
for Stereo Audio****OVERVIEW**

The LA4571MB is a low-voltage, stereo headphone amplifier incorporating both tape head preamplifiers and headphone power amplifiers in a single chip, making it ideal for portable battery-powered equipment. It features logic-level controlled output signal muting, excellent noise characteristics and easy interconnection with signal sources, such as an AM/FM tuner IC.

The LA4571MB requires no input or output coupling capacitors. A buffer amplifier with 10 Ω output impedance reduces the size of the virtual-earth decoupling capacitor. The preamplifier and power amplifier inputs only require the addition of an external capacitor to provide high-frequency noise filtering.

The LA4571MB operates from a 3 V supply and is available in 20-pin MFPs.

FEATURES

- Stereo tape head preamplifiers and headphone power amplifiers on chip
- Output signal muting
- Low noise
- 8 Ω speaker driver
- 3 V supply
- 20-pin MFP

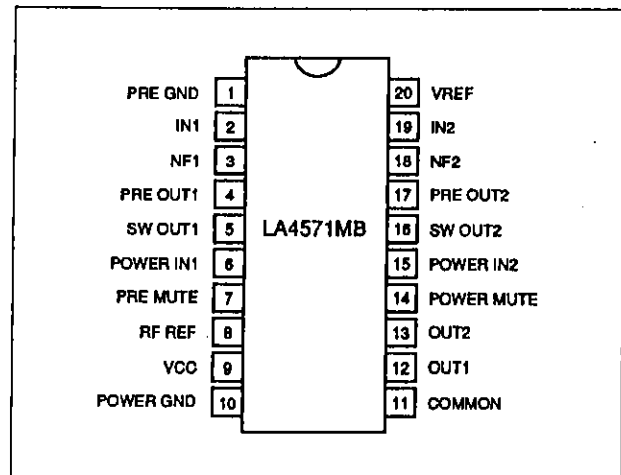
PINOUT**PACKAGE DIMENSIONS**

Unit: mm

3036B-MFP20

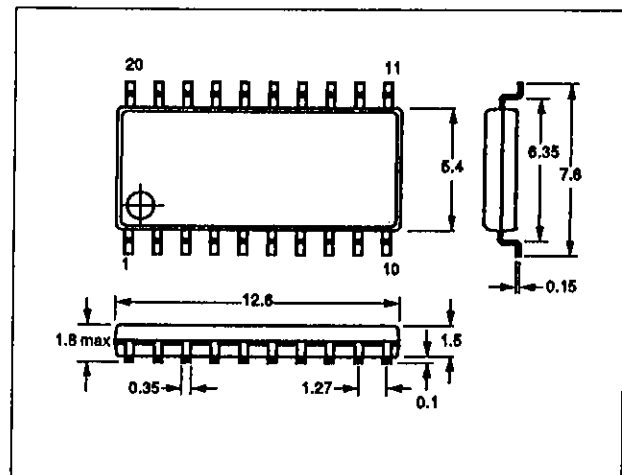

BLOCK DIAGRAM

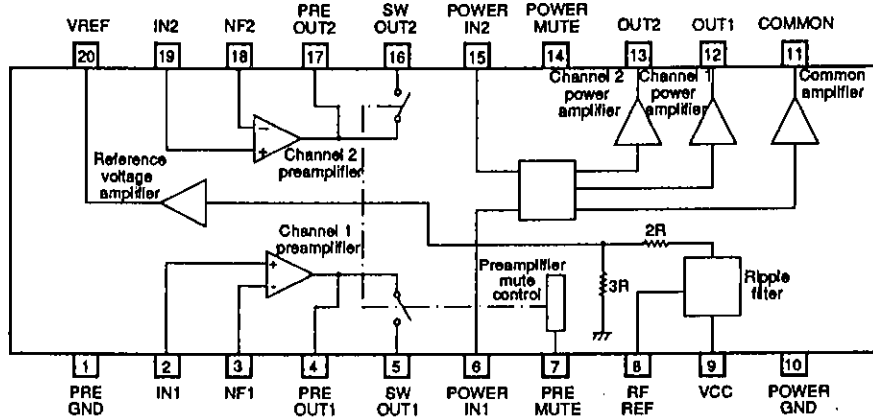

PIN DESCRIPTION

Number	Name	Description
1	PRE GND	Preamplifier ground
2	IN1	Channel 1 preamplifier input
3	NF1	Channel 1 preamplifier negative feedback input
4	PRE OUT1	Channel 1 preamplifier output
5	SW OUT1	Channel 1 preamplifier mute-control switched output. $R_{IN} \geq 500 \text{ k}\Omega$
6	POWER IN1	Channel 1 power amplifier input. $R_{IN} \approx 30 \text{ k}\Omega$
7	PRE MUTE	Preamplifier mute control
8	RF REF	Ripple-filter capacitor connection
9	VCC	Supply voltage
10	POWER GND	Power amplifier ground
11	COMMON	Common amplifier output
12	OUT1	Channel 1 power amplifier output
13	OUT2	Channel 2 power amplifier output
14	POWER MUTE	Power amplifier mute control
15	POWER IN2	Channel 2 power amplifier input. $R_{IN} \approx 30 \text{ k}\Omega$
16	SW OUT2	Channel 2 preamplifier mute-control switched output. $R_{IN} \geq 500 \text{ k}\Omega$
17	PRE OUT2	Channel 2 preamplifier output
18	NF2	Channel 2 preamplifier negative feedback input
19	IN2	Channel 2 preamplifier input
20	VREF	Reference-voltage amplifier output. $I_{max} = \pm 500 \mu\text{A}$

SPECIFICATIONS

Absolute Maximum Ratings

Parameter	Symbol	Rating	Unit
Supply voltage	V_{CC} max	4.5	V
Power dissipation	P_d max	400	mW
Operating temperature range	T_{OPR}	-20 to 75	deg. C
Storage temperature range	T_{STG}	-40 to 125	deg. C

Recommended Operating Conditions

$T_a = 25$ deg. C

Parameter	Symbol	Rating	Unit
Supply voltage	V_{CC}	3.0	V
Supply voltage range	V_{CC} op	1.8 to 3.6	V

Electrical Characteristics

Preamplifier and power amplifier

$V_{CC} = 3.0$ V, $T_a = 25$ deg. C, $f = 1$ kHz, R_L (pre) = 10 k Ω , R_L (power) = 16 Ω , 0 dBm at 0.775 V unless otherwise noted

Parameter	Symbol	Condition	Rating			Unit
			min	typ	max	
Quiescent supply current	I_{CCQ}	$R_g = 2.2$ k Ω , $V_i = 0$ V	–	17	27	mA
Total voltage gain	VG_T	$V_o = -5$ dBm	65	68	71	dB

Preamplifier

$V_{CC} = 3.0$ V, $T_a = 25$ deg. C, $f = 1$ kHz, R_L (pre) = 10 k Ω , R_L (power) = 16 Ω , 0 dBm at 0.775 V unless otherwise noted

Parameter	Symbol	Condition	Rating			Unit
			min	typ	max	
Open-loop voltage gain	VG_o	$V_o = -5$ dBm	70	80	–	dB
Closed-loop voltage gain	VG_1	$V_o = -5$ dBm	–	40	–	dB
Maximum output voltage	V_o max	THD = 1%, $V_{CC} = 1.8$ V	0.1	0.2	–	V
Total harmonic distortion	THD_1	$V_o = 0.2$ V, $VG = 40$ dB (NAB standard)	–	0.05	0.5	%
Input conversion noise voltage	V_{NI}	$R_g = 2.2$ k Ω , bandwidth = 20 Hz to 20 kHz	–	1.3	2.0	μ V
Channel crosstalk	CT_1	$R_g = 2.2$ k Ω , 1 kHz tone	60	80	–	dB
Ripple rejection	R_{r1}	$R_g = 2.2$ k Ω , $V_{CC} = 1.8$ V, $V_r = -20$ dBm, $f_r = 100$ Hz	40	50	–	dB

LA4571MB

Power amplifier

$V_{CC} = 3.0 \text{ V}$, $T_a = 25 \text{ deg. C}$, $f = 1 \text{ kHz}$, $R_L \text{ (pre)} = 10 \text{ k}\Omega$, $R_L \text{ (power)} = 16 \Omega$, 0 dBm at 0.775 V unless otherwise noted

Parameter	Symbol	Condition	Rating			Unit
			min	typ	max	
Output power	P_o		23	32	-	mW
Closed-loop voltage gain	V_{G2}	$V_o = -5 \text{ dBm}$	25	28	31	dB
Total harmonic distortion	THD_2	$P_o = 1 \text{ mW}$	-	0.4	1.0	%
Channel crosstalk	CT_T	$V_o = -5 \text{ dBm}$, $R_v = 0 \Omega$	30	40	-	dB
Output noise voltage	V_{NO}	$R_o = 0 \Omega$, bandwidth = 20 Hz to 20 kHz	-	24	40	μV
Ripple rejection	R_{r2}	$R_o = 0 \Omega$, $V_r = -20 \text{ dBm}$, $f_r = 100 \text{ Hz}$, $V_{CC} = 1.8 \text{ V}$	45	60	-	dB
Input resistance	R_i		22	30	38	$\text{k}\Omega$
Output DC offset voltage	V_{OS}		-90	-	90	mV

Measurement circuit

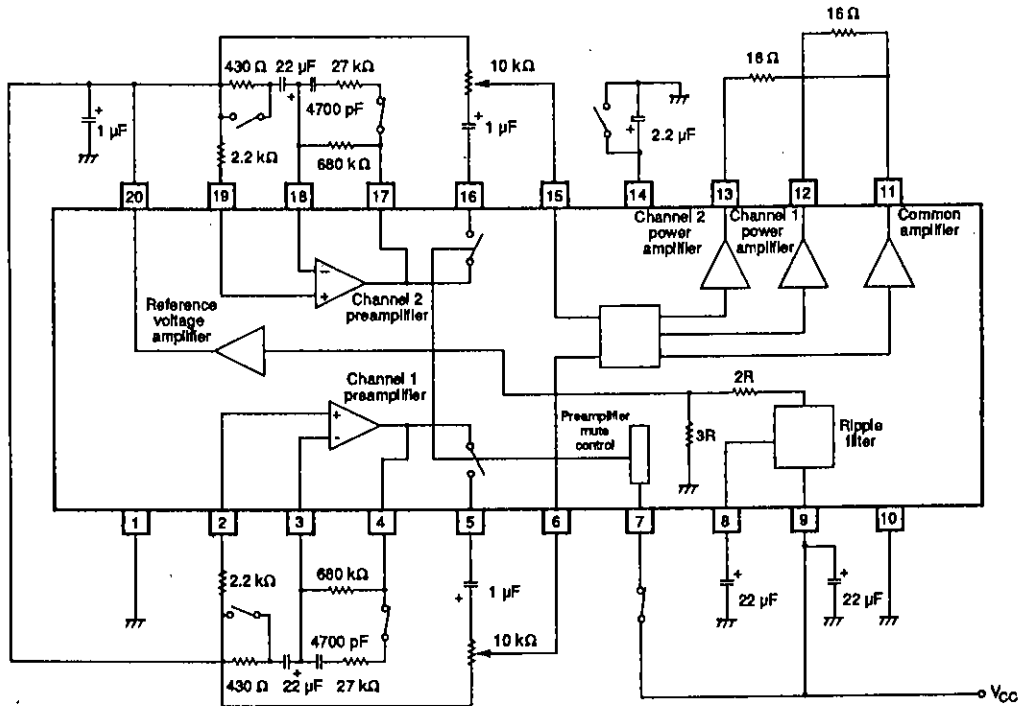

Typical Performance Characteristics

Preamplifier and power amplifier

Maximum power dissipation vs. temperature

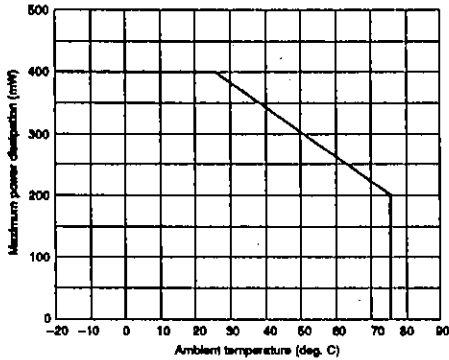

Quiescent supply current vs. supply voltage

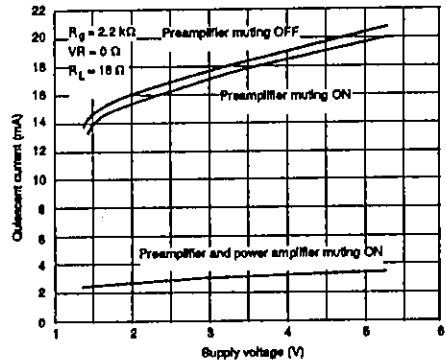

Preamplifier

Frequency response

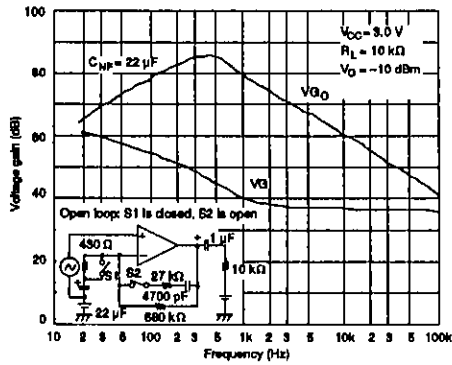

Total harmonic distortion vs. output voltage

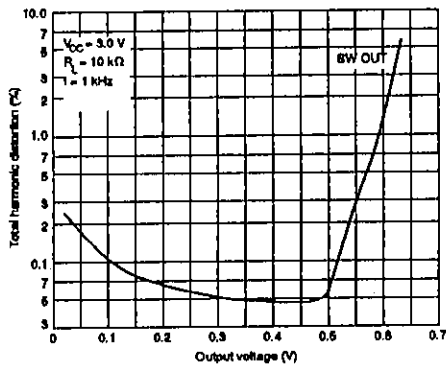

Open-loop voltage gain vs. supply voltage

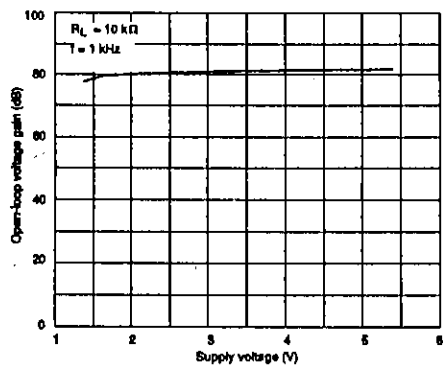

Maximum output voltage vs. supply voltage

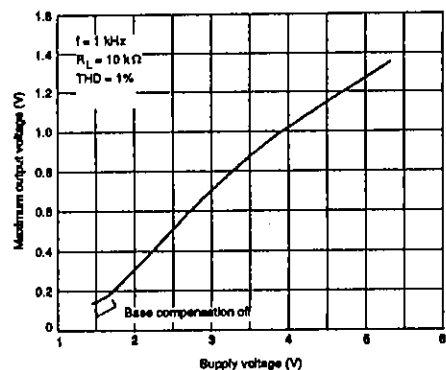

Channel crosstalk vs. frequency

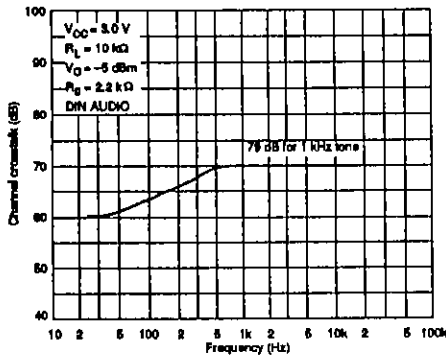

Output noise voltage vs. supply voltage

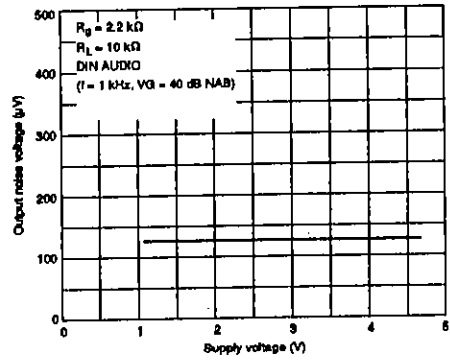

Reference-voltage amplifier

Output level vs. frequency

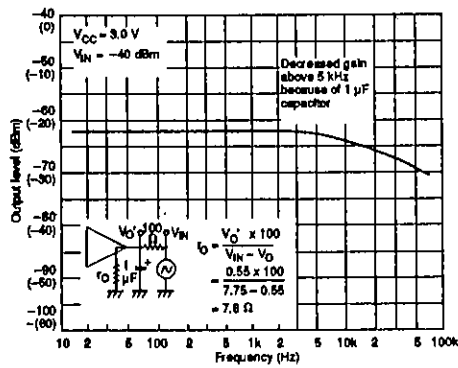

Supply voltage rejection ratio vs. supply voltage

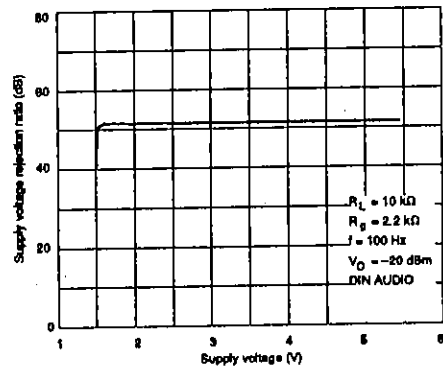

Reference voltage vs. output current

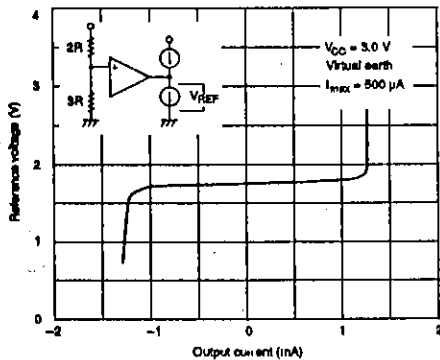

Power amplifier

DC voltage vs. supply voltage

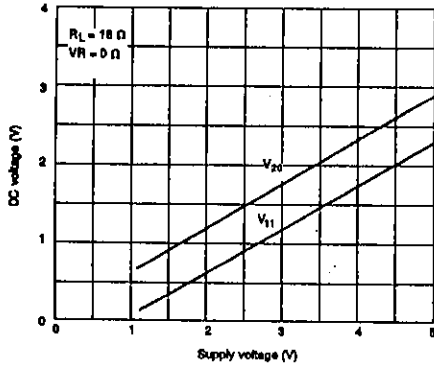

Channel crosstalk vs. frequency

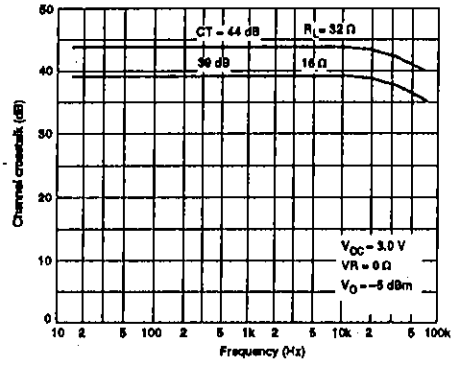

Maximum output voltage vs. supply voltage

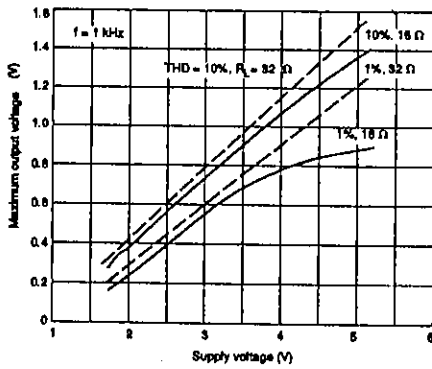

Total harmonic distortion vs. supply voltage

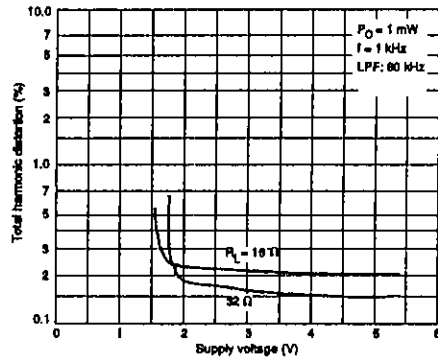

Frequency response

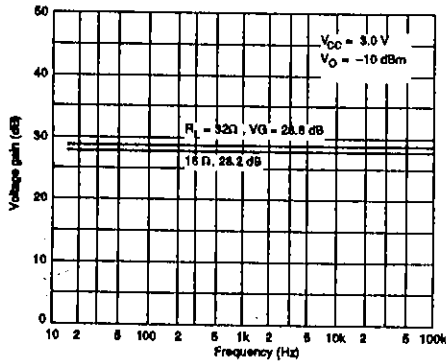

Total harmonic distortion vs. output power (1)

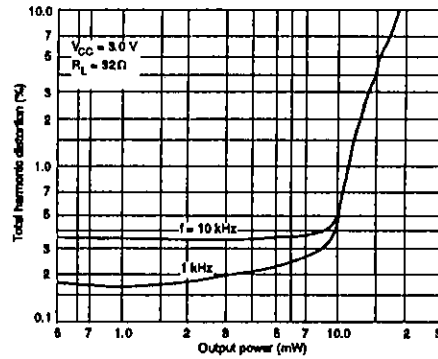

Voltage gain vs. supply voltage

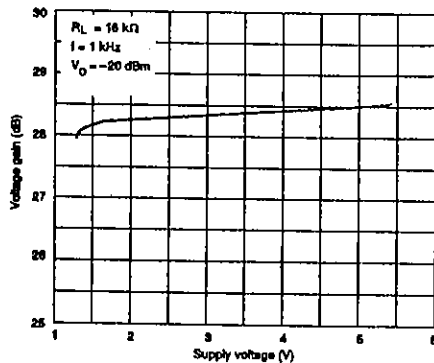

Total harmonic distortion vs. output power (2)

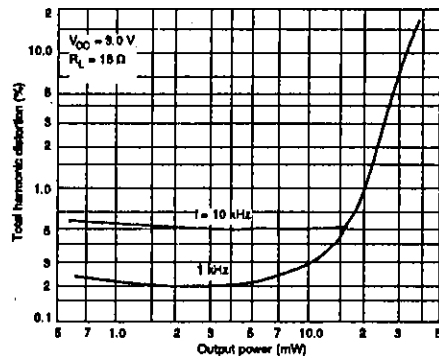

Output noise voltage vs. supply current

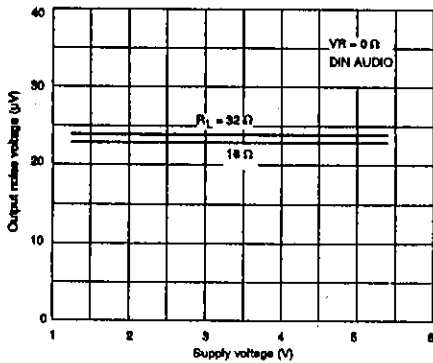

Supply voltage rejection ratio vs. supply voltage

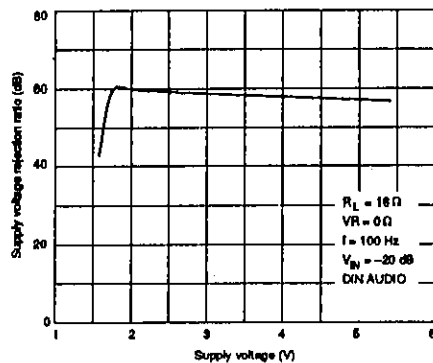

FUNCTIONAL DESCRIPTION (channel 1 only)

Tape Head Preamp

Tape head signal sources are connected to the non-inverting input of the op-amp, negative feedback preamplifier.

When PRE MUTE is open, the preamplifier output is connected to SW OUT1, and when PRE MUTE is HIGH ($V_{CC} \pm 0.2$ V at 60 μ A input current), SW OUT1 is open. This can be used to switch, or mute, the preamplifier output.

The following figure shows a circuit with preamplifier muting which amplifies an audio signal from an RF tuner.

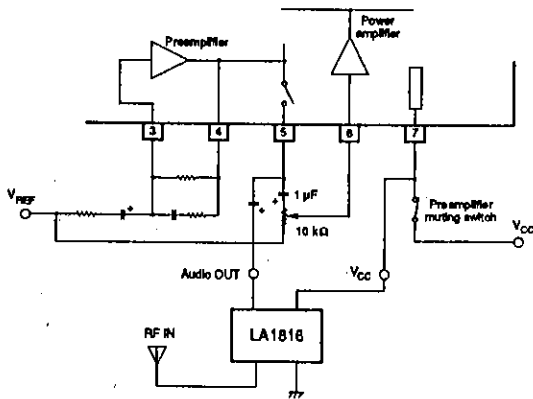

The internal circuit of the PRE MUTE pin is shown in the following figure.

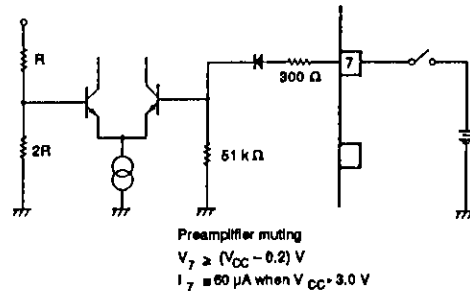

The output pins, PRE OUT1 and SW OUT1, can both drive a 10 k Ω load resistance.

The preamplifier input pin, IN1, the negative feedback input pin, NF1, and the output pin, PRE OUT1, are biased at 1.8 V.

Power Amplifier

The power amplifier stage comprises an amplifier for each channel and a common amplifier. The power amplifier outputs are connected internally by 60 Ω resistors to prevent oscillation, as shown in the following figure.

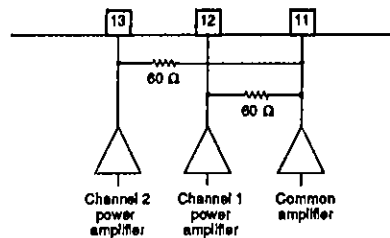

When POWER MUTE is LOW (less than 0.3 V at 2.5 μ A input current), the power amplifier output signal is muted. The power amplifier mute release time is set by an external capacitor.

The internal circuit of the POWER MUTE pin is shown in the following figure.

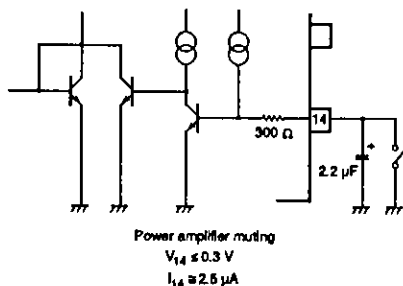

The power amplifier input pin, POWER IN1, is biased at 1.8 V, and the output pins at 1.2 V.

DESIGN NOTES

The preamplifier inputs should be connected to V_{REF} through a 2.2 k Ω resistor if there is no tape head input signal source.

The mute release time capacitor of the power amplifier should be between 1.0 and 4.7 μF . For $V_{CC} = 3.0 \text{ V}$ and $C = 2.2 \mu\text{F}$, the mute release time is 0.7 s.

The ripple rejection ratio setting capacitor should be between 2.2 and 33 μF . For 2.2 μF , the ripple rejection ratio is 35 dB, and for 22 μF , it is 55 dB.

When the output amplifier turns OFF, the protection circuit shown in the following figure detects the falling

Reference Voltage

The input to the voltage reference amplifier is a voltage divided level from the supply voltage ripple filter. The reference voltage is given by $0.6 \times V_{CC}$.

The supply voltage ripple filter requires the connection of an external filter capacitor to RF REF. A large capacitance results in a high ripple rejection ratio.

Noise filtering is achieved by the addition of a single capacitor to VREF. Since the reference voltage amplifier has a buffered output, this capacitor can be as low as 1 μF .

supply voltage and then mutes the power amplifier to protect the device.

