

SANYO

No.2157A

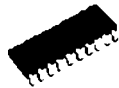

LA4580M

Monolithic Linear IC
2-CHANNEL PREAMP + POWER AMP FOR
3V HEADPHONE USE

The LA4580M is a single-chip pre/power amp IC designed for 3V auto reverse stereo headphone use.

Features

- 2-channel IC containing preamplifiers and power amplifiers on a single chip.
- On-chip electronic switch for forward/reverse select
(Time required for forward/reverse select can be controlled by an external capacitor.)
- On-chip LED driver
- 20-pin MFP package

Maximum Ratings at Ta=25°C

			unit
Maximum Supply Voltage	V _{CC} max	4.5	V
Allowable Power Dissipation	P _d max	400	mW
Operating Temperature	Topg	-20 to +75	°C
Storage Temperature	Tstg	-40 to +125	°C

Operating Conditions at Ta=25°C

			unit
Recommended Supply Voltage	V _{CC}	3	V
Operating Voltage Range	V _{CC} op	1.8 to 3.6	V
Recommended Load Resistance	R _L	16 to 32	ohm

Operating Characteristics at Ta=25°C, V_{CC}=3V, f=1kHz

			min	typ	max	unit
Preamp: R _L =10kohms						
Voltage Gain	V _{Go}	Open loop	75	86		dB
Voltage Gain	V _G	Closed loop, V _o =0.2V		41.5		dB
Maximum Output Voltage	V _o	THD=1%	0.35	0.45		V
Total Harmonic Distortion	THD	V _o =0.2V		0.06	0.2	%
Ripple Rejection	R _r	f _r =100Hz, R _g =2.2kohms	40	50		dB
Equivalent Input Noise Voltage	V _{NI}	V _{CCr} =-10dBm R _g =2.2kohms, B.P.F.=20Hz to 20kHz		1.0	2.0	uV
F/R Crosstalk	C _{F/R}	R _g =2.2kohms, V _o =-3dBm	60	70		dB

Continued on next page.

The application circuit diagrams and circuit constants herein are included as an example and provide no guarantee for designing equipment to be mass produced. The information herein is believed to be accurate and reliable. However, no responsibility is assumed by SANYO for its use, nor for any infringements of patents or other rights of third parties which may result from its use.

Case Outline 3036B-M20IC

(unit:mm)

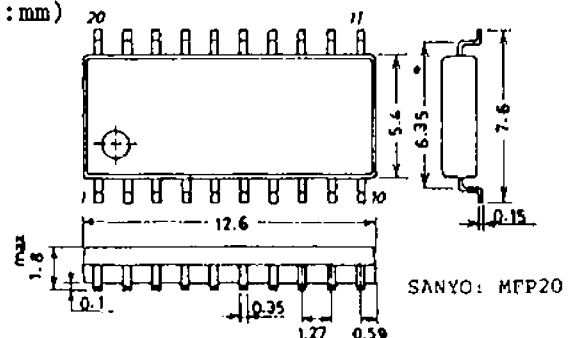

SANYO: MFP20

Specifications and information herein are subject to change without notice.

SANYO Electric Co., Ltd. Semiconductor Overseas Marketing Div.
Natsume Bldg., 18-6, 2-chome, Yushima, Bunkyo-ku, TOKYO 113 JAPAN

Continued from preceding page.

Power Amp: $R_L=32\text{ohms}$ (pure resistance)			min	typ	max	unit
Output Power	Po1	THD=10%, $R_L=16\text{ohms}$	28	40		mW
	Po2	THD=10%, $R_L=32\text{ohms}$	15	20		mW
Voltage Gain	VG	$V_o=0.18V$	26	29	32	dB
Total Harmonic Distortion	THD	$P_o=1\text{mW}(0.18V)$		0.2	1.0	%
Input Resistance	r_i		22	30	38	kohm
Output Noise Voltage	V_{NO}	$R_g=0, B.P.F.=20\text{Hz to }20\text{kHz}$		21	32	μV
Ripple Rejection	Rr	$f_r=100\text{Hz}, R_g=0, V_{CCr}=-10\text{dBm}$	40	50		dB
Crosstalk between Channels	CT _{CH}	$R_g=0, V_o=0.55V$	30	37		dB
Pre+Power Amp						
Quiescent Current	I _{qoo}	EQ+Power		9	16	mA
R/L Crosstalk	CT _{CH}	$R_g=2.2\text{kohms}, V_o=-3\text{dBm}$	30	36		dB

Test Circuit

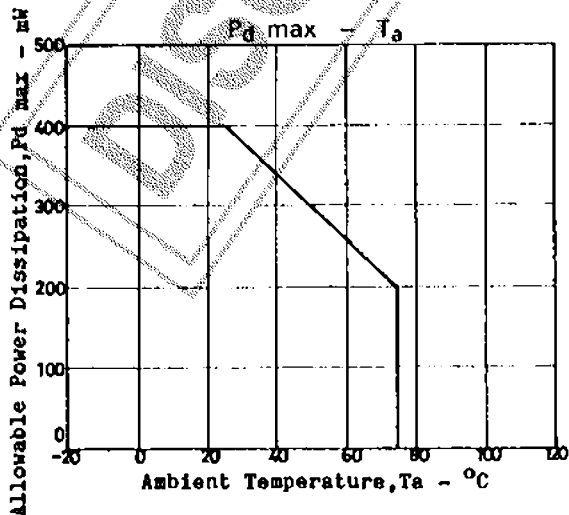
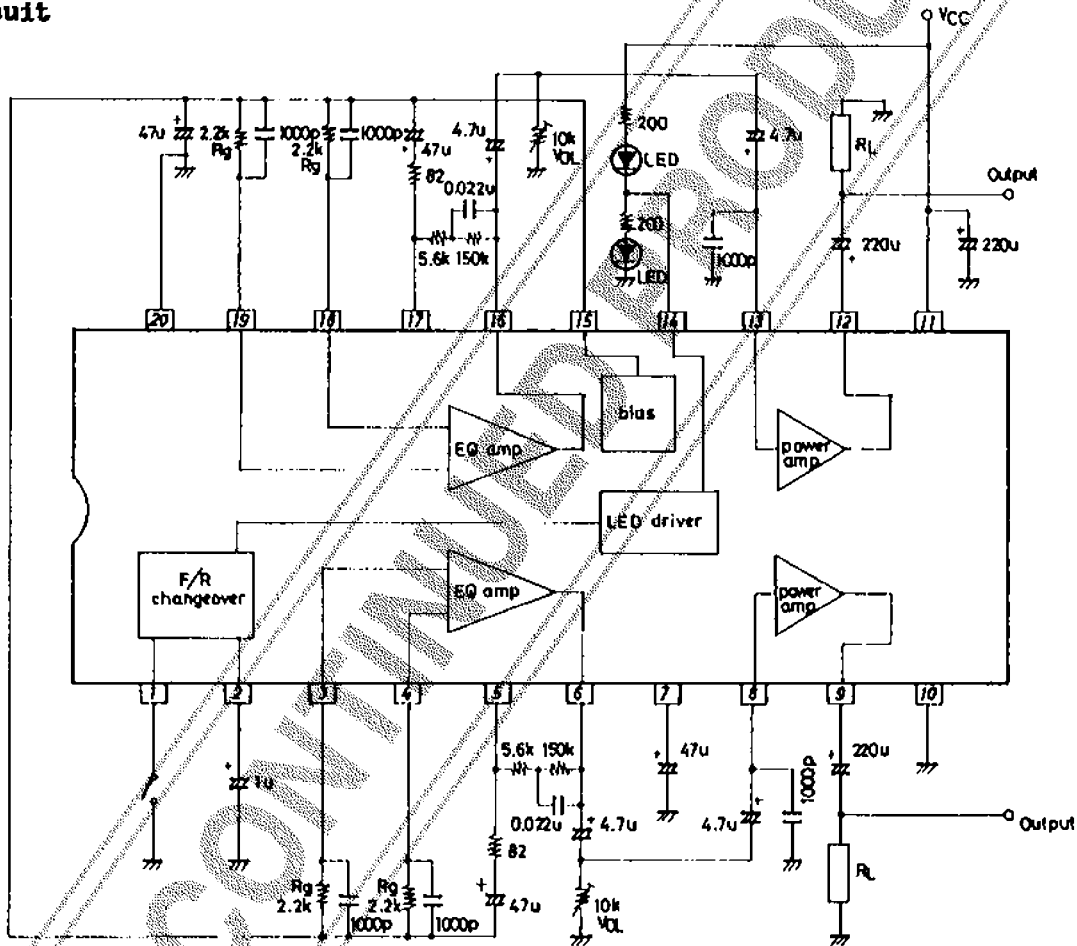

LA4580M

Sample Application Circuit (1): Power input capacitor method

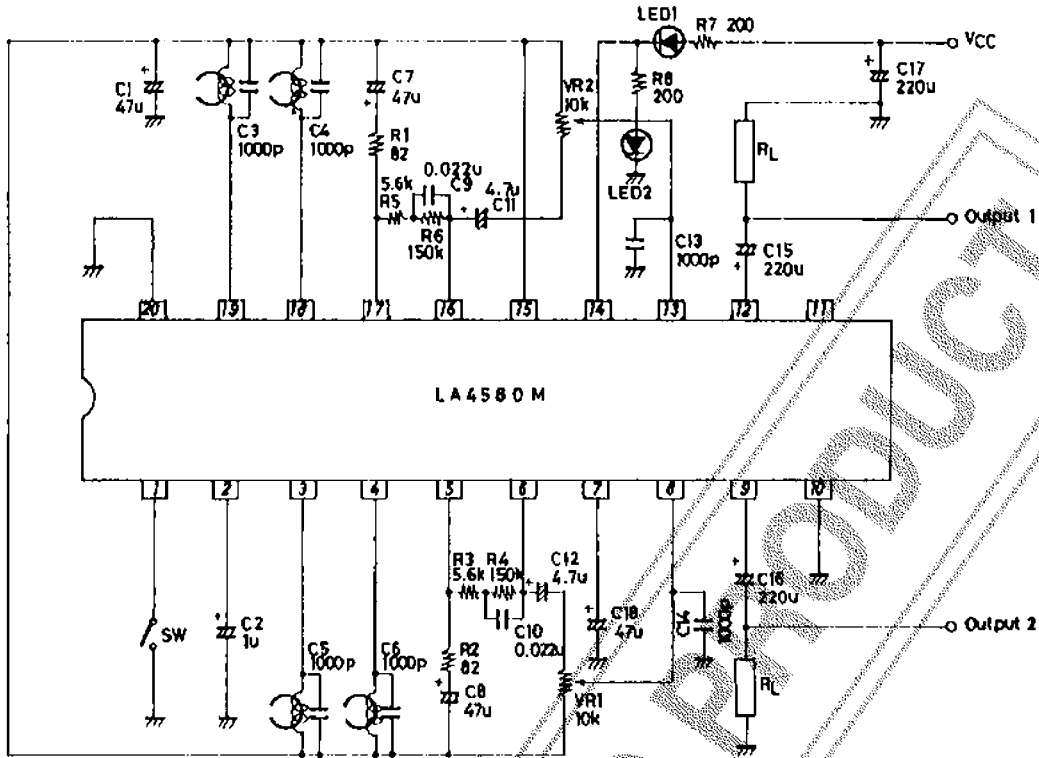

Sample Application Circuit (2): Power output capacitor common method

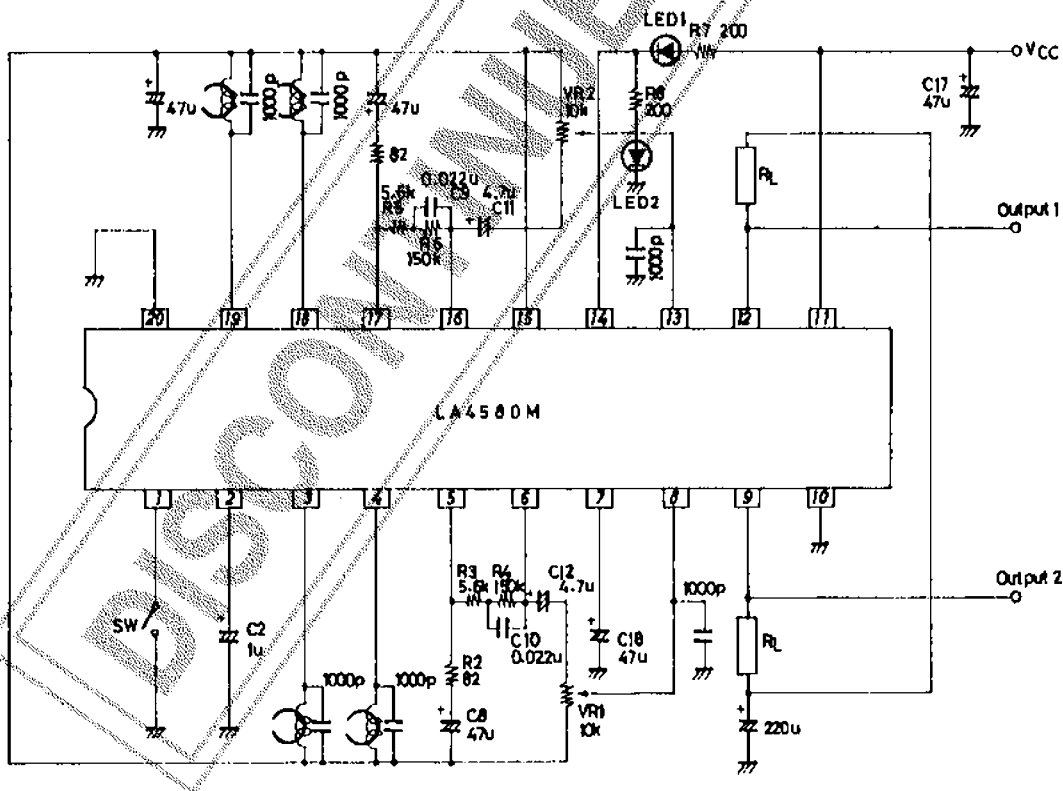

Description of External Parts [Power input capacitor method]

C1: Electrolytic capacitor

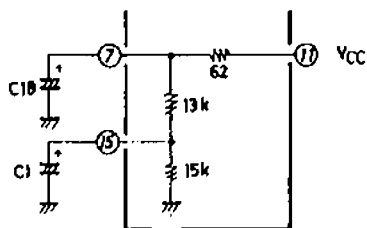

Connected to virtual GND reference voltage generation pin 15. The capacitor value is 33uF or greater. The C1 is so made as to be charged rapidly from GND potential to approximately 0.7V.

$$V_{15} \approx \frac{1}{2} V_{CC}$$

C18: Electrolytic capacitor,

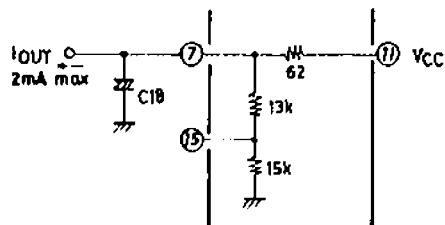

Used for ripple filter and connected to the preamplifiers and bias circuit. The capacitor value is 47uF or greater. Current can be drawn from pin 7, but it should be noted that current draw from pin 7 causes an increase in voltage drop across pins 11 and 7, causing the voltage on pin 15 to drop and the power amp output power to drop.

$$I_{OUT} \approx 2\text{mA max}$$

C2: Used to set F/R switching time t . The capacitor value of 1uF gives switching time t of approximately 0.16 second. Switching time t is increased by approximately 0.16 second with every additional 1uF of capacitor value.

(Refer to F/R Switching Time - Timing Capacitor Characteristic.)

C3,C4,C5,C6: Used to prevent external noise from mixing in. The capacitor value is fixed according to the frequency characteristic of the playback head.

C7,C8: Negative feedback capacitor. 100uF or less. The lower limit is determined by the low cutoff frequency.

C9,C10: Used to determine the playback equalizer characteristics.

C11,C12: Preamp output capacitor. We recommend using a capacitor of 4.7uF. 1 to 10uF.

C13,C14: Used to prevent radiation and power amp oscillation from occurring.

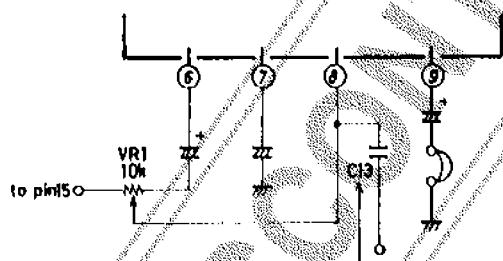

We recommend using a capacitor of 1000pF. One plate of the C13 and C14 may be connected to virtual GND pin 15 or preamp GND pin 20 according to your intended printed circuit pattern so that the LA4580M exhibits better characteristics.

Connect to pin 15 or pin 20.

C15,C16: Power amp output capacitor. We recommend using a capacitor of 220uF.

C17: Power line capacitor. We recommend using a capacitor of 220uF.

R1,R2: Closed-loop gain setting resistor. $R1=R2=82\text{ohms}$ gives a gain of 41dB/1kHz.

R3,R5: Used to determine the playback equalizer amp characteristics.

R4,R6: Used to determine the playback equalizer characteristics. Since R3,R4 (or R5,R6) are not only used to determine the frequency characteristic but also used as DC feedback resistor, do not connect a capacitor in series to block DC components. It should be noted that an increase in R3,R4 (or R5,R6) may cause an increase in output DC offset of the playback preamp, increasing the noise that is generated at the time of FWD/REV selection.

$$R3+R4 \text{ (or } R5+R6) = 500\text{kohms max.}$$

LA4580M

R7,R8: LED current limiting resistor

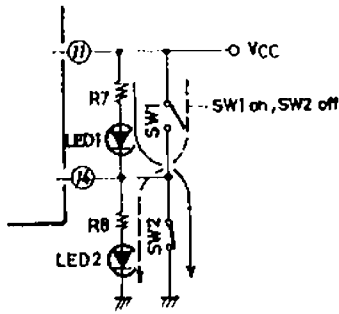

Used to limit the current flowing in the LED.

$$I_{LED} = \frac{V_{CC} - V_{LED1}}{R7} = \frac{V_{CC} - V_{LED}}{R8}$$

V_{LED1}, V_{LED2} (at LED ON mode)
Forward voltage=1V

$I_{LED\ max} = 15mA$

When the LEDs are not used,
pin 14 may be left open.

	Pin 1 GND level	Pin 1 open level
SW1	on	off
SW2	off	on

Oscillation of power amp (When a headphone is mounted)

If oscillation occurs with a headphone mounted, connect a capacitor of 22000pF across the headphone.

F/R selection

The preamp input selection can be made by bringing pin 1 to open state, GND level.

Pin ① open Pins ③, ⑱ ON
Pin ① GND Pins ④, ⑲ ON

When F/R selection is not made it is recommended that both of pins ①, ② are left open. In this case, pins ③, ⑱ only are used as input pins.

Bias voltage on each pin of LA4580M

Pin No.	VCC=1.8V	VCC=3.0V	VCC=4.5V
1	0-1.315	0-1.322	0-1.322
2	1.331-0.01	1.328-0.01	1.329-0.011
3	0.843	1.441	2.119
4	0.844	1.441	2.123
5	0.859	1.445	2.156
6	0.949	1.515	2.219
7	1.849	2.799	4.237
8	0.791	1.333	2.016
9	0.466	0.947	1.485
10	G	G	G
11	1.80	3.00	4.50
12	0.472	1.002	1.639
13	0.787	1.307	1.960
14	0.010	0.125	0.266
15	0.847	1.424	2.148
16	0.910	1.488	2.189
17	0.851	1.432	2.135
18	0.850	1.427	2.120
19	0.848	1.423	2.123
20	G	G	G

LA4580M

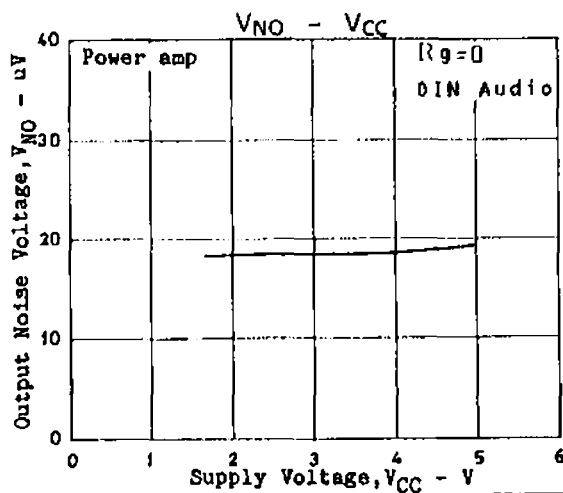
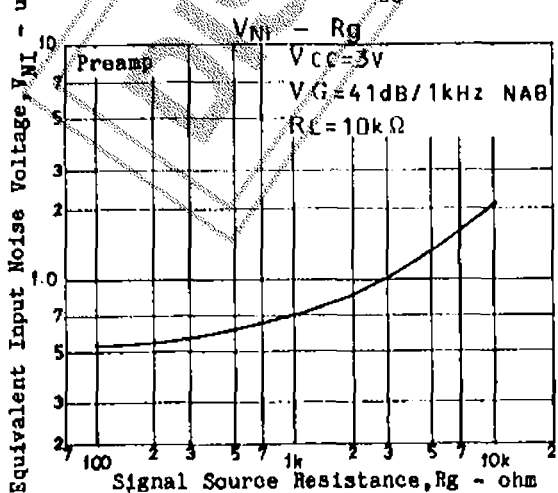
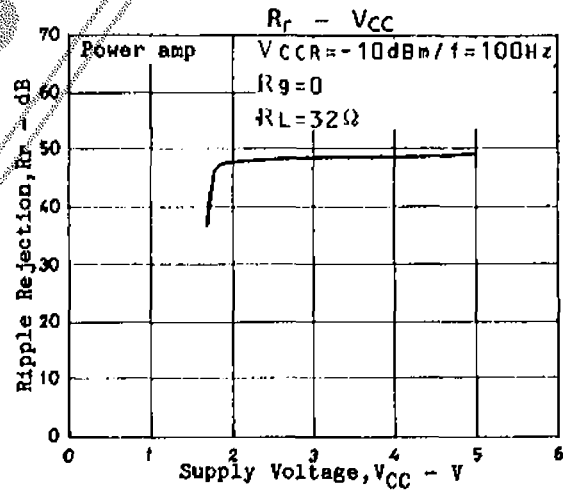
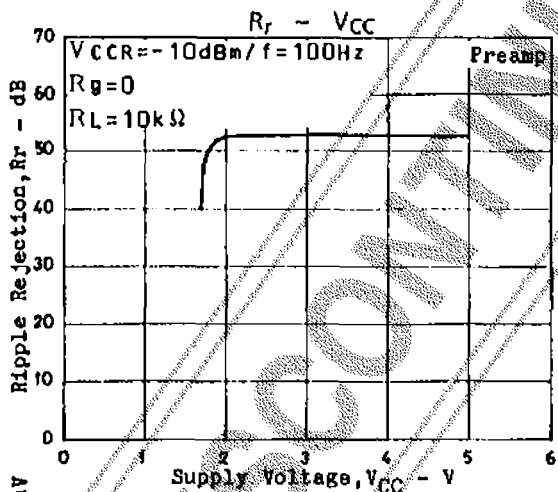
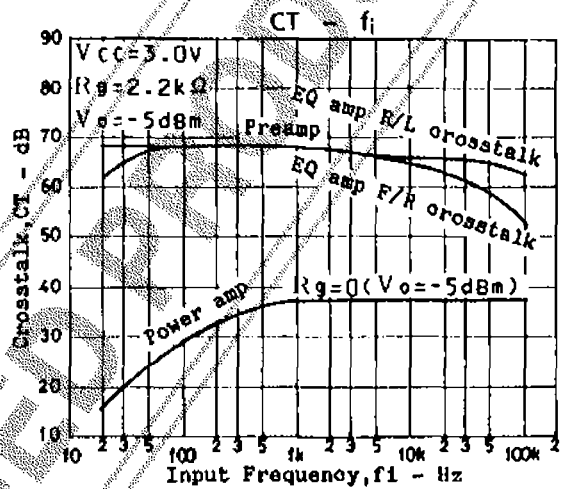
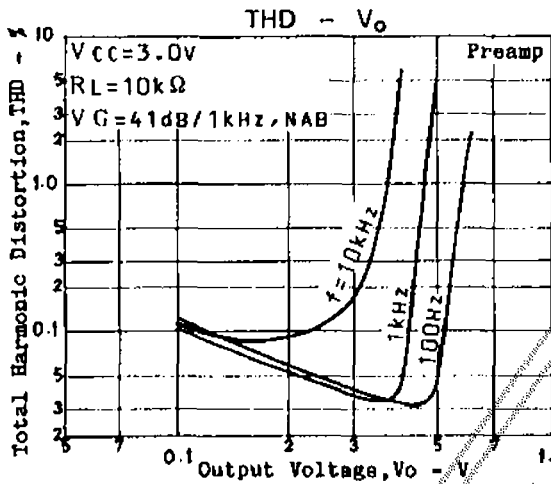
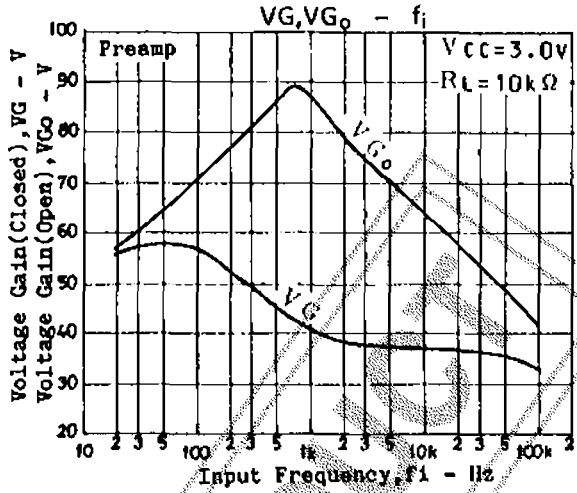
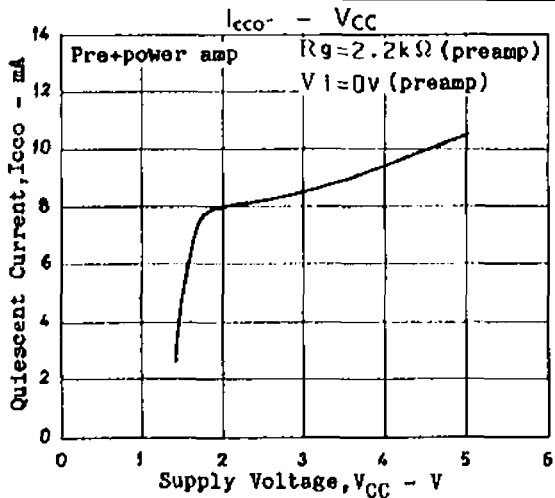

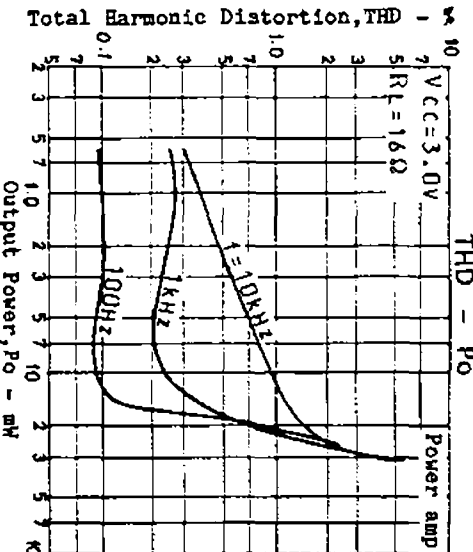
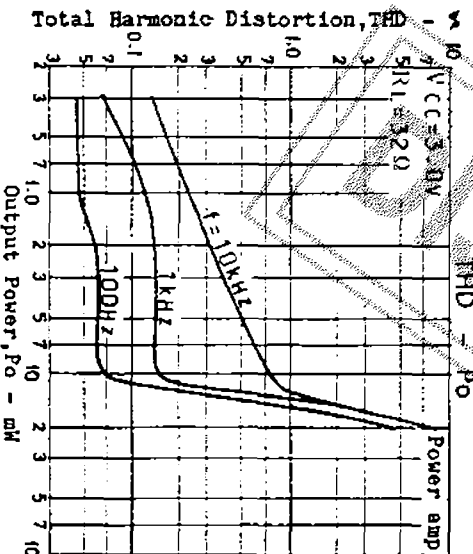
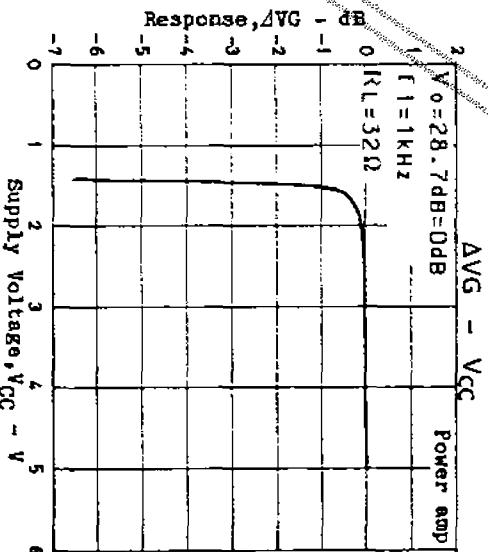
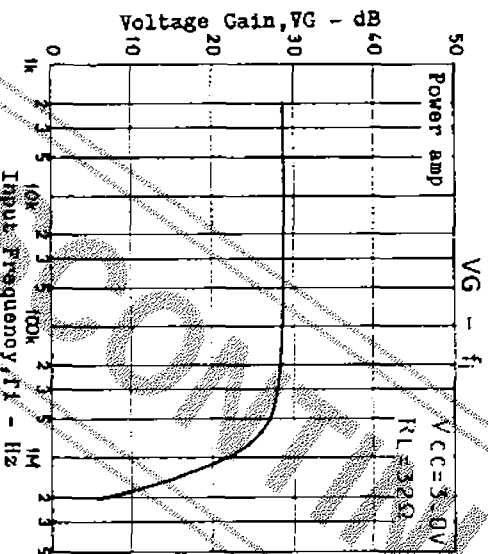
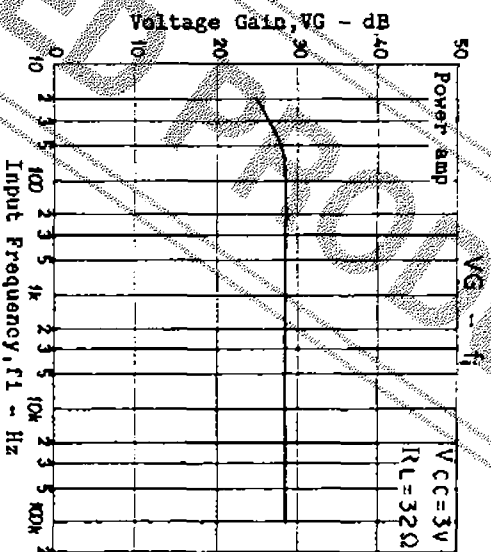
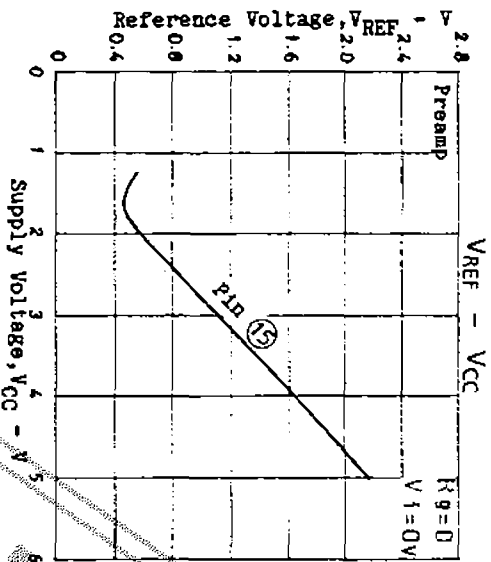
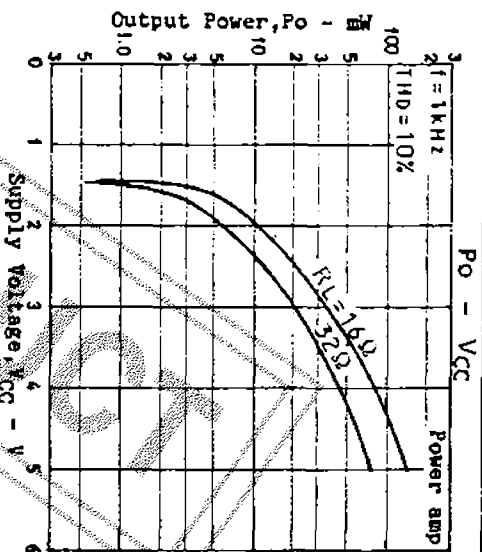
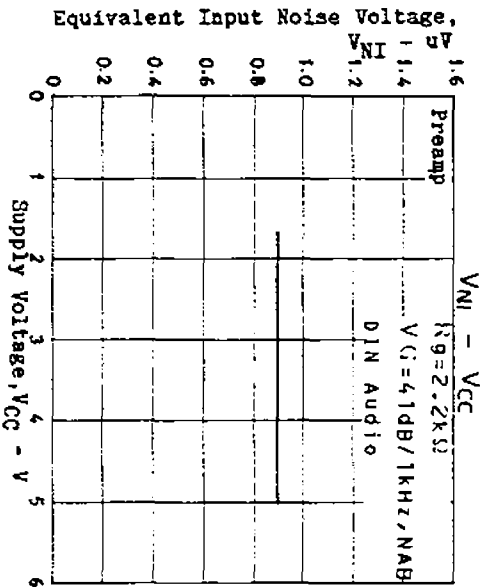

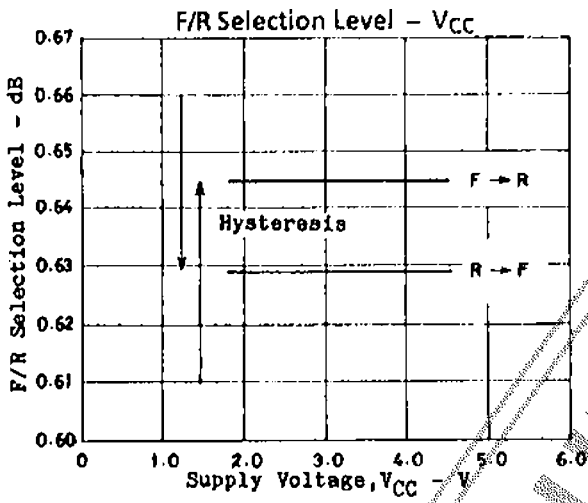
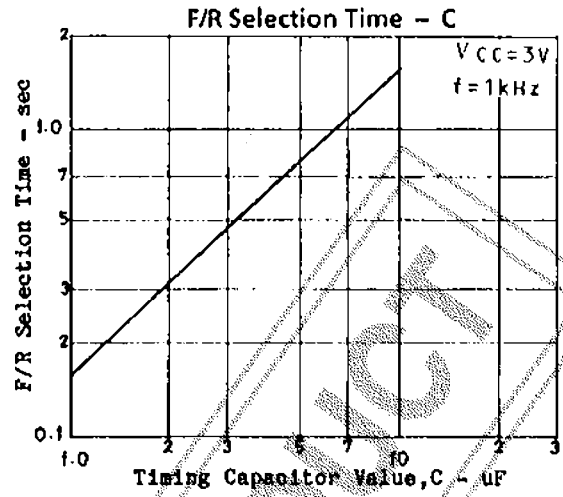
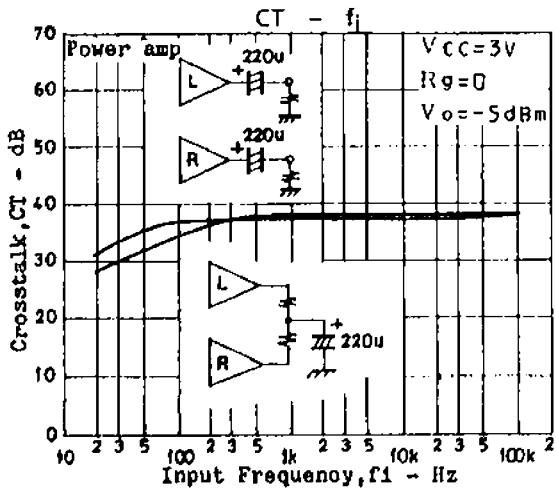

DISCONTINUED PRODUCT