



LA7565B, 7565BM

IF Signal-Processing IC for PAL/NTSC Multi-System Audio TV and VCR Products

Overview

The LA7565B/M is a PAL/NTSC multi-system audio VIF/SIF signal-processing IC that adopts a minimal-adjustment technique. The VIF circuit adopts a minimal-adjustment technique in which AFT adjustment is made unnecessary by VCO adjustment to simply end product adjustment. The FM detector circuit uses PLL detections to support multi-system audio detection. Since the LA7565BM include an SIF converter on chip, it is easy to implement multi-system audio. In addition, it also includes a buzz canceller that suppresses Nyquist buzz to achieve improved audio quality.

Functions

[VIF Block]

- Minimal adjustment PLL detector
- AFT
- RF AGC
- Equalizer amplifier
- SIF converter

[First SIF Block]

- First SIF detector
- Inter/split switch
- HPF

[SIF Block]

- PLL type FM detector

[Mute Block]

- AV mute

Features

- Allows the use of a switch circuit to switch between split and intercarrier operation.
- Improved buzz and buzz beat characteristics provided by a PLL detector plus buzz canceller system.
- The IF AGC second filter is built in.
- PAL/NTSC multi-system audio can be implemented easily.
- Adjustment-free circuit design that does not require AFT and SIF coils.

Package Dimensions

unit: mm

3067-DIP24S

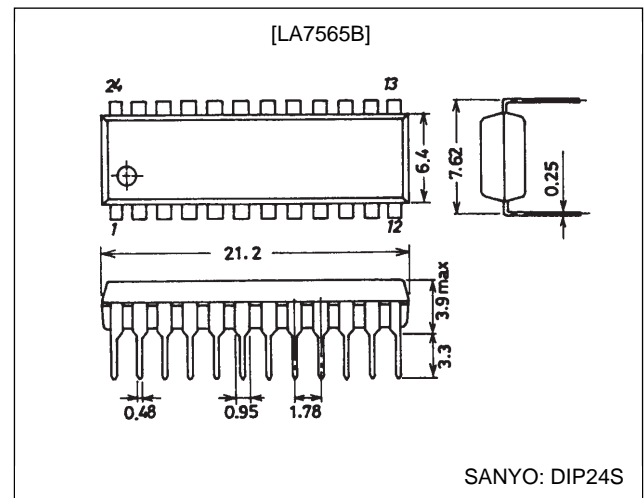

unit: mm

3112-MFP24S

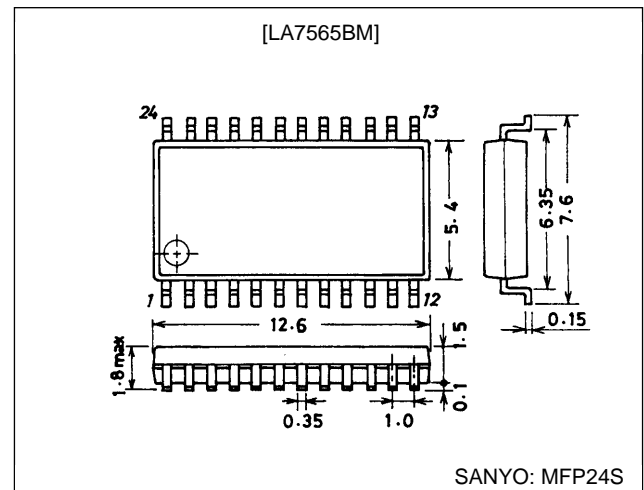

LA7565B, 7565BM

Specifications

Maximum Rating at Ta = 25°C

| Parameter | Symbol | Conditions | Ratings | Unit |
|-----------------------------|---------------------|---|-----------------|------|
| Maximum supply voltage | V _{CC} max | | 10 | V |
| Circuit voltage | V13, V17 | | V _{CC} | V |
| Circuit current | I6 | | -3 | mA |
| | I10 | | -10 | mA |
| | I24 | | -2 | mA |
| Allowable power dissipation | Pd max | (LA7565B) Ta ≤ 68°C | 720 | mW |
| | | (LA7565BM) Ta ≤ 50°C, independent IC | 420 | mW |
| | | (LA7565BM) * Mounted on a printed circuit board | 720 | mW |
| Operating temperature | Topr | | -20 to +70 | °C |
| Storage temperature | Tstg | | -55 to +150 | °C |

Note: * When mounted on a 65 × 72 × 1.6 mm epoxy glass laminate printed circuit board.

Operating Conditions

| Parameter | Symbol | Conditions | Ratings | Unit |
|----------------------------|--------------------|------------|------------|------|
| Recommended supply voltage | V _{CC} | | 9 | V |
| Operating supply voltage | V _{CC} op | | 8.5 to 9.5 | V |

Electrical Characteristics at Ta = 25°C, V_{CC} = 9 V, fp = 38.9 MHz

| Parameter | Symbol | Conditions | Ratings | | | Unit |
|----------------------------------|---------------------|------------|---------|------|------|--------|
| | | | min | typ | max | |
| [VIF Block] | | | | | | |
| Circuit current | I ₅ | | 37.4 | 44 | 50.6 | mA |
| Maximum RF AGC voltage | V _{14H} | | 7.5 | 8.1 | | V |
| Minimum RF AGC voltage | V _{14L} | | | 0 | 0.5 | V |
| Input sensitivity | V _{IN} | S1 = OFF | 26 | 32 | 38 | dBμV |
| AGC range | G _R | | 62 | 68 | | dB |
| Maximum allowable input | V _{IN} max | | 92 | 97 | | dBμV |
| No-signal video output voltage | V ₆ | | 3.5 | 3.8 | 4.2 | V |
| Synchronizing signal tip voltage | V ₆ tip | | 1.15 | 1.45 | 1.74 | V |
| Video output level | V _O | | 1.7 | 2.0 | 2.3 | Vp-p |
| Black noise threshold voltage | V _{BTH} | | 0.5 | 0.8 | 1.1 | V |
| Black noise clamp voltage | V _{BCL} | | 2.5 | 2.8 | 3.1 | V |
| Video S/N ratio | S/N | | 48 | 50 | | dB |
| C-S beat | IC-S | | 38 | 43 | | dB |
| Frequency characteristics | f _C | 6 MHz | -3 | -1.5 | | dB |
| Differential gain | DG | | | 3 | 6.5 | % |
| Differential phase | DP | | | 3 | 5 | deg |
| No-signal AFT voltage | V ₁₃ | | 3.5 | 4.4 | 5.5 | V |
| Maximum AFT voltage | V _{13H} | | 8 | 8.7 | 9 | V |
| Minimum AFT voltage | V _{13L} | | 0 | 0.18 | 1 | V |
| AFT detection sensitivity | Sf | | 25 | 36 | 47 | mV/kHz |
| VIF input resistance | Ri | 38.9 MHz | | 1.5 | | kΩ |
| VIF input capacitance | Ci | 38.9 MHz | | 3 | | pF |
| APC pull-in range (U) | f _{PU} | | 0.8 | 1.3 | | MHz |
| APC pull-in range (L) | f _{PL} | | | -1.5 | -0.8 | MHz |
| AFT tolerance frequency 1 | d _{fa} 1 | | -500 | 0 | +500 | kHz |
| VCO1 maximum frequency range (U) | d _{fu} | | 1.0 | 1.3 | | MHz |
| VCO1 maximum frequency range (L) | d _{fl} | | | -1.5 | -1 | MHz |
| VCO control sensitivity | B | | 0.9 | 1.8 | 3.6 | kHz/mV |

Continued on next page.

LA7565B, 7565BM

Continued from preceding page.

| Parameter | Symbol | Conditions | Ratings | | | Unit |
|-----------------------------|----------------------|------------------|---------|-----|------|-------|
| | | | min | typ | max | |
| [First SIF Block] | | | | | | |
| Conversion gain | VG | | 37.5 | 43 | 49.5 | dB |
| 5.5 MHz output level | S _O | | 46 | 100 | 150 | mVrms |
| First SIF maximum input | S _i max | | 112 | 223 | | mVrms |
| First SIF input resistance | R _i (SIF) | 33.4 MHz | | 2 | | kΩ |
| First SIF input capacitance | C _i (SIF) | 33.4 MHz | | 3 | | pF |
| [SIF Block] | | | | | | |
| Limiting voltage | V _i (lim) | | 43 | 48 | 53 | dBμV |
| FM detector output voltage | V _O (FM) | 5.5 MHz ± 30 kHz | 720 | 900 | 1100 | mVrms |
| AM rejection ratio | AMR | | 50 | 60 | | dB |
| Total harmonic distortion | THD | | | 0.3 | 0.8 | % |
| SIF S/N ratio | S/N (FM) | | 57 | 62 | | dB |
| [SIF Converter] | | | | | | |
| Conversion gain | VG (SIF) | | 7 | 11 | 14 | dB |
| Maximum output level | V max | | 102 | 108 | 111 | dBμV |
| Carrier suppression ratio | VGR (5.5) | | 14 | 26 | | dB |
| Oscillator level | V _{OSC} | | | 70 | | mVp-p |
| Oscillator leakage | OSCleak | | 8 | 24 | | dB |
| Oscillator stopped current | I ₄ | | | | 300 | μA |

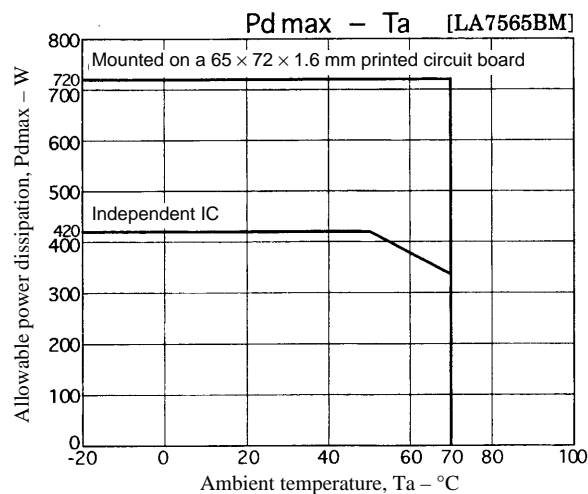
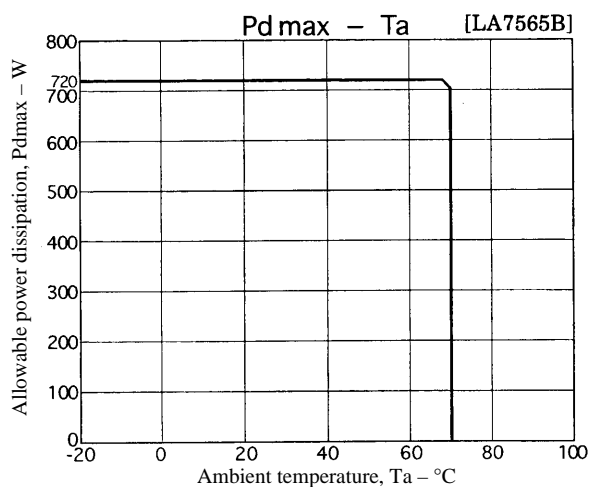

LA7565B, 7565BM

Internal Equivalent Circuit and External Circuit Diagram

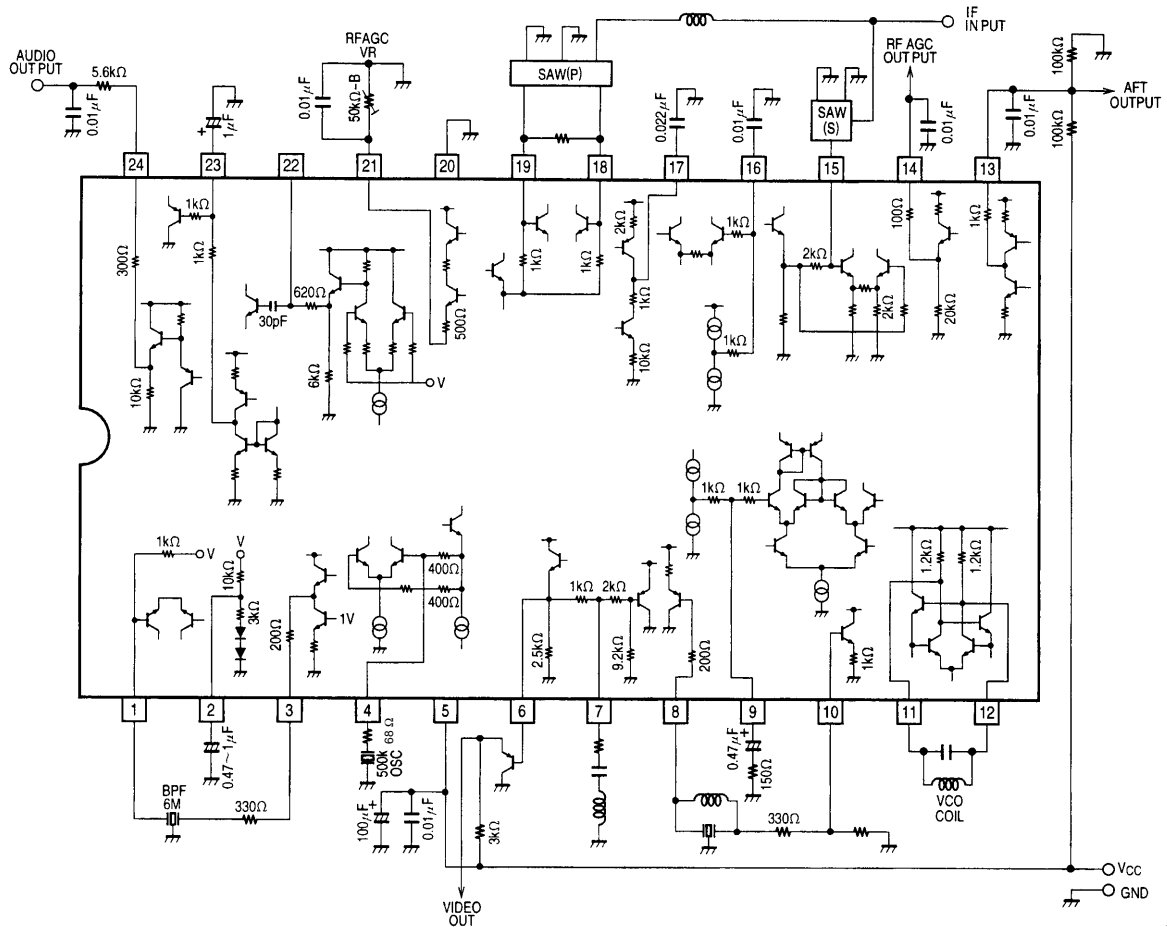

T00049

LA7565B, 7565BM

AC Characteristics Test Circuit

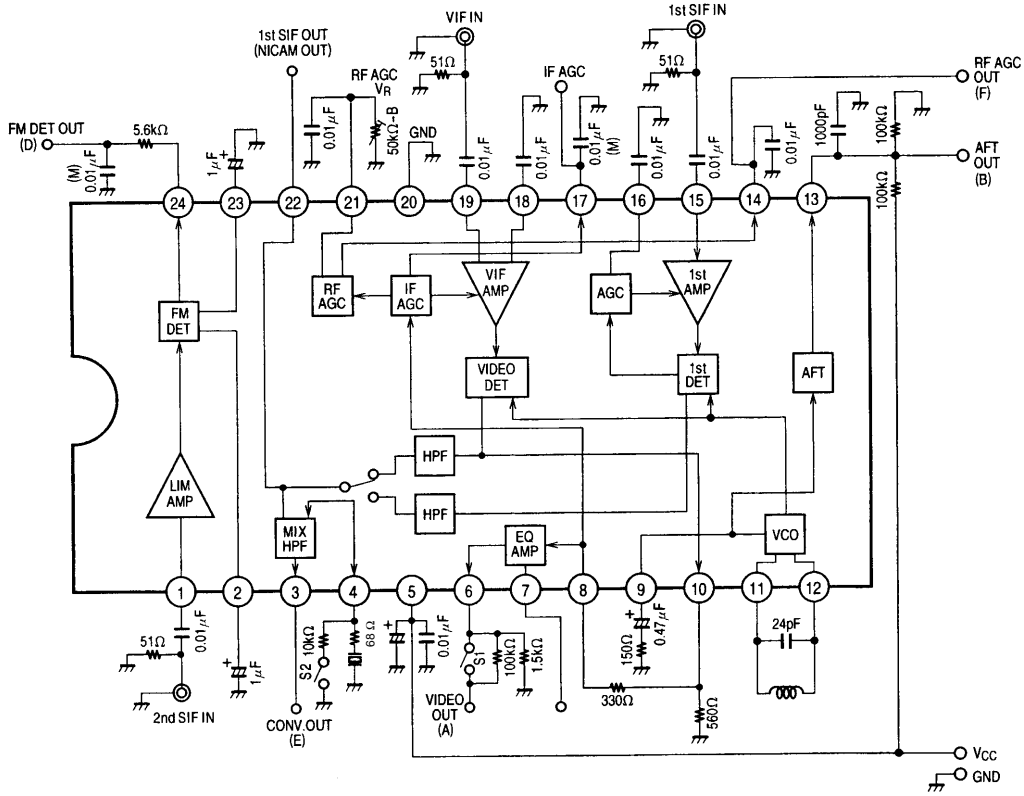

T00053

Test Circuit

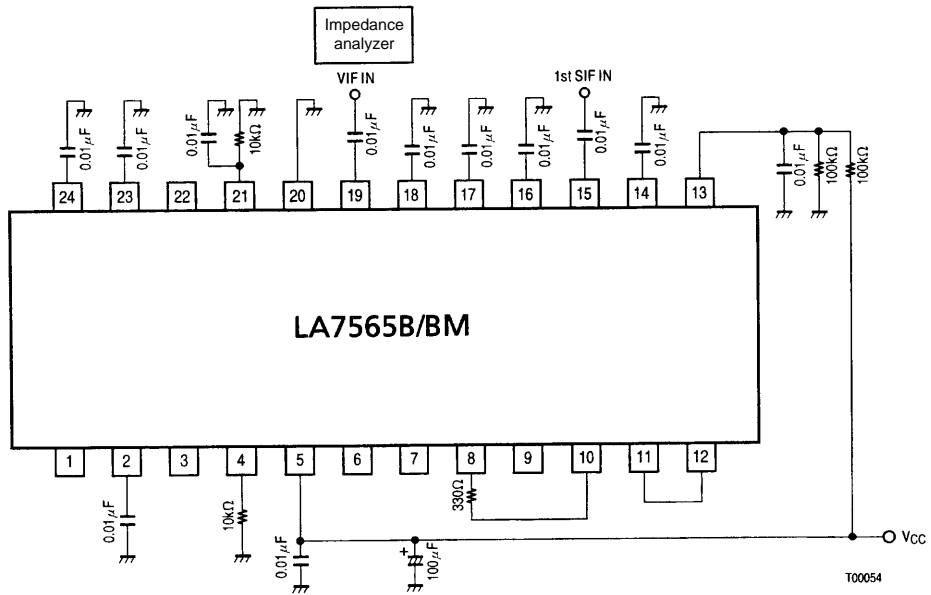

T00054

LA7565B, 7565BM

Sample Application Circuit
PAL SPLIT

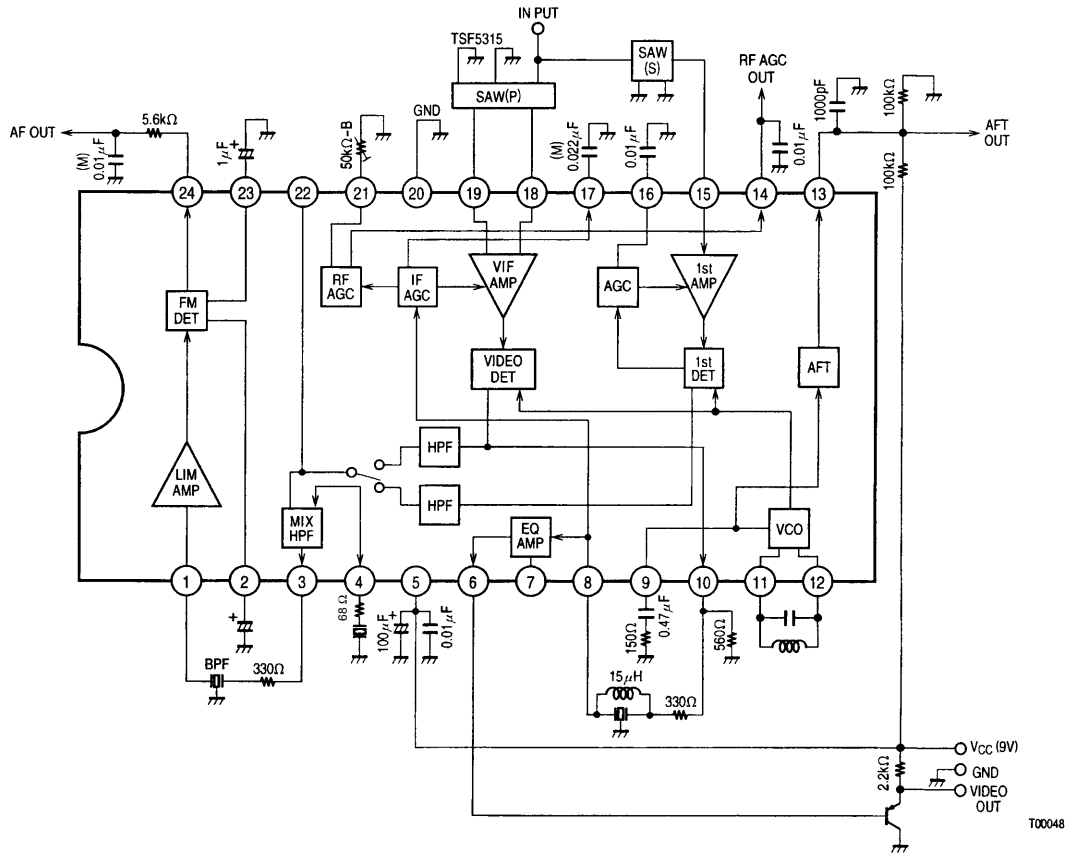

NT (US) SPLIT

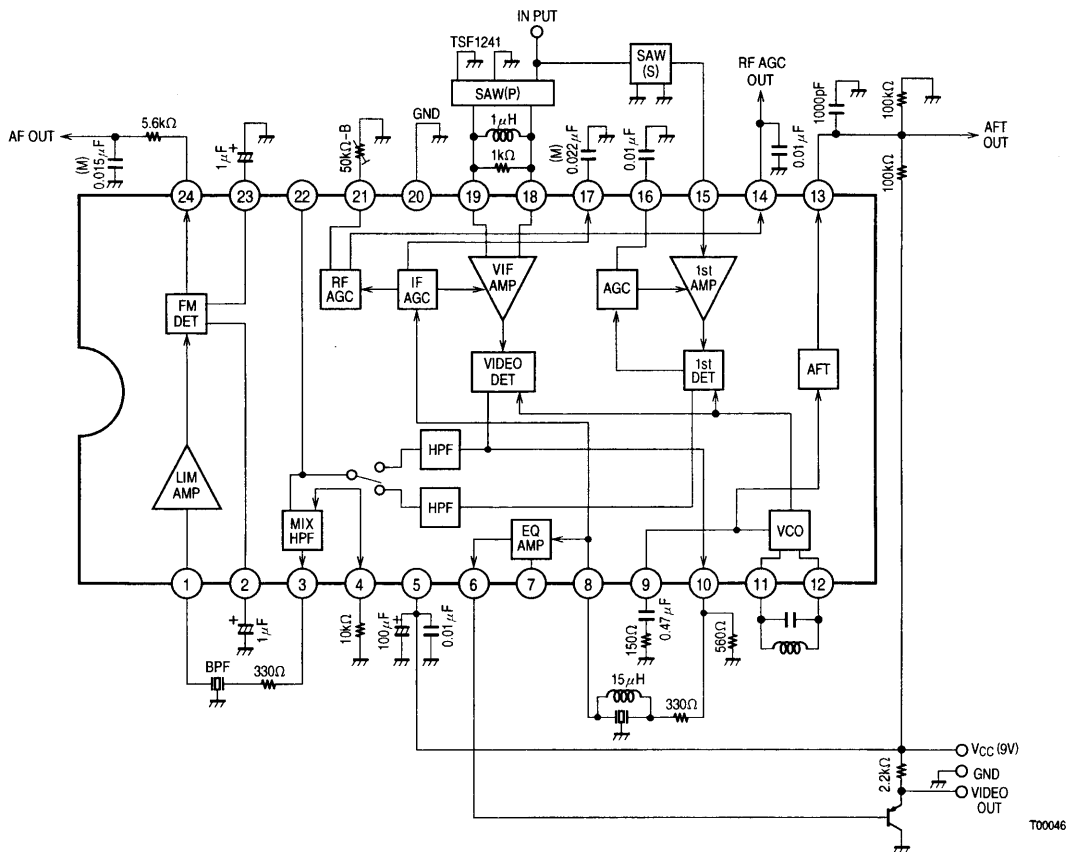

LA7565B, 7565BM

JAPAN SPLIT

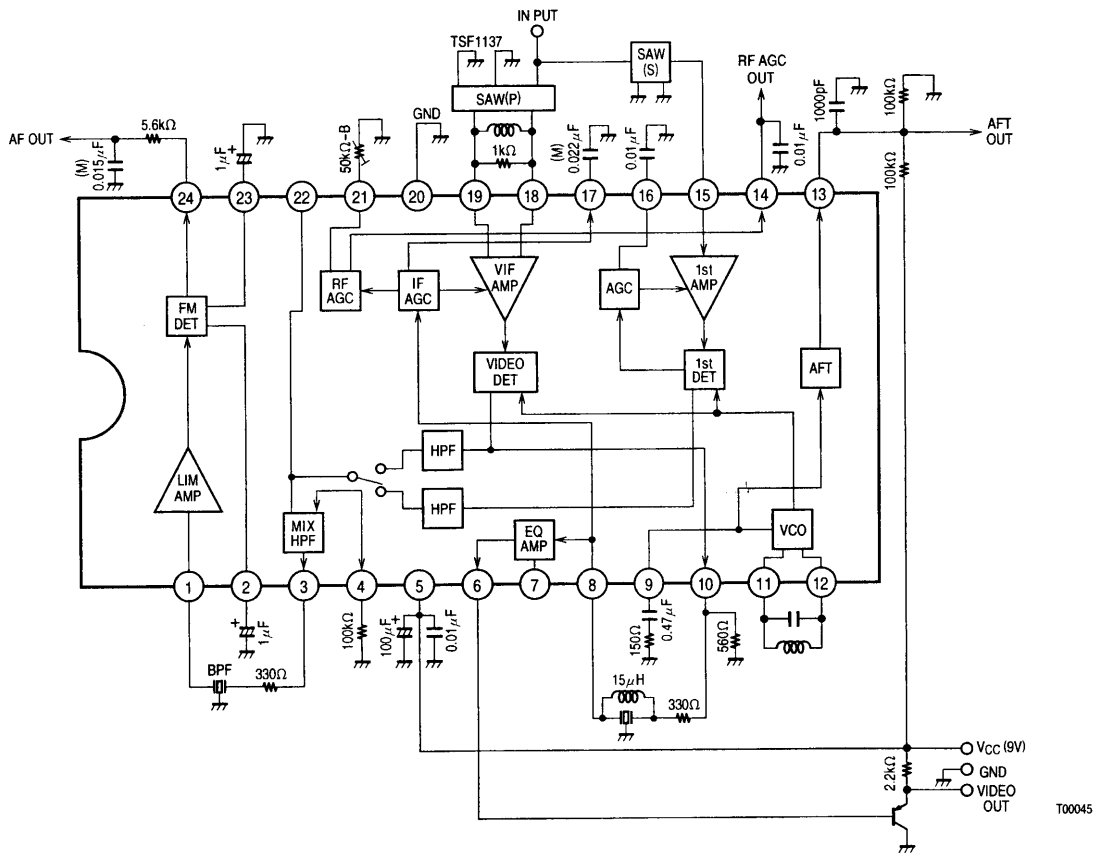

NT (US) INTER

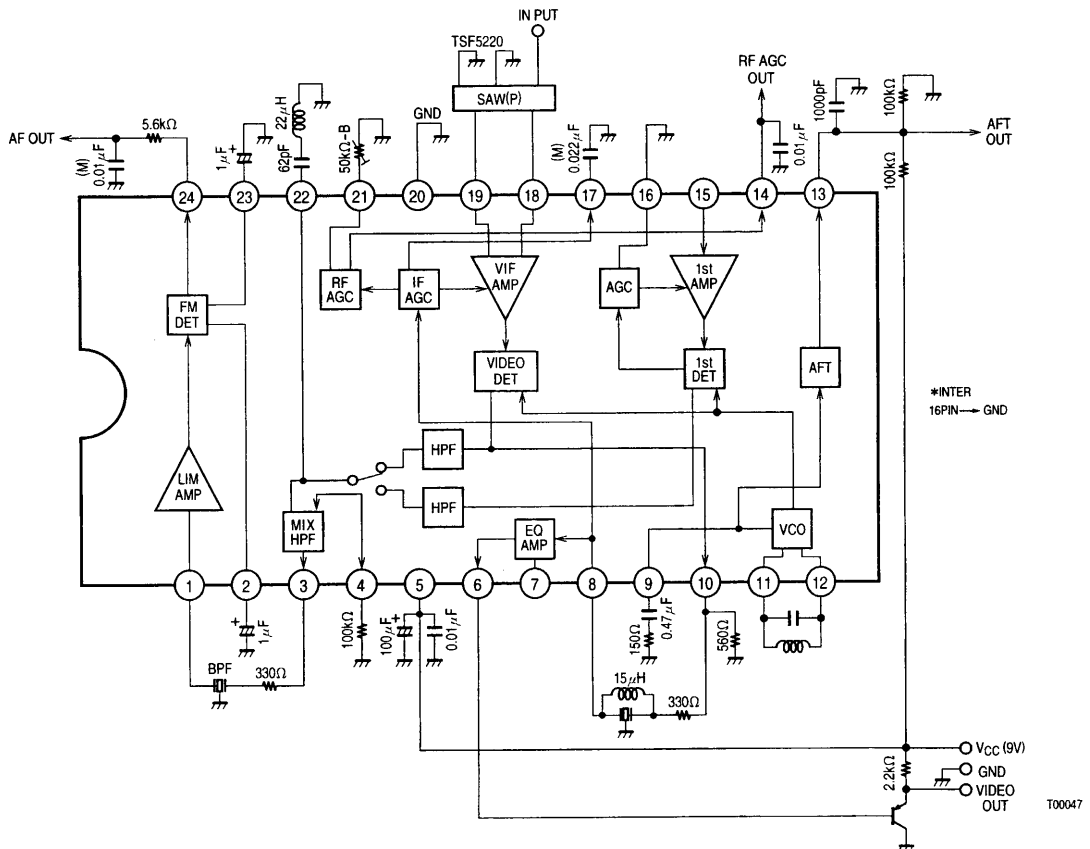

LA7565B, 7565BM

Sample Application Circuit (2)

When the SIF, first SIF, AFT, and RF AGC circuits are not used.

- When the SIF circuit is not used:
Leave pins 1, 23, and 24 open.
Insert a 2-k Ω resistor between pin 2 and ground.
- When the first SIF circuit is not used:
Leave pins 3, 4, 15, and 22 open.
Connect pin 16 to ground.
- When the AFT circuit is not used:
Since there is no way to defeat the AFT circuit, connect a 100-k Ω resistor and a 0.01- μ F capacitor in parallel between pin 13 and ground.
- When the RF AGC circuit is not used:
Leave pins 14 and 21 open.
A 0.01- μ F capacitor must be inserted between pin 21 and ground to prevent oscillation.

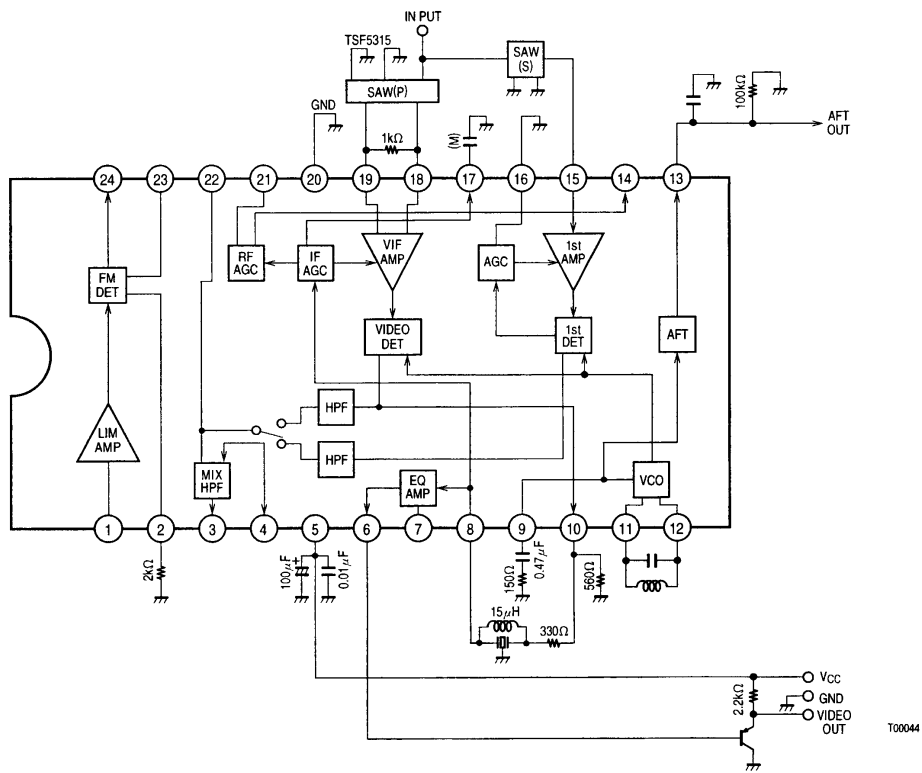

Pin Assignment

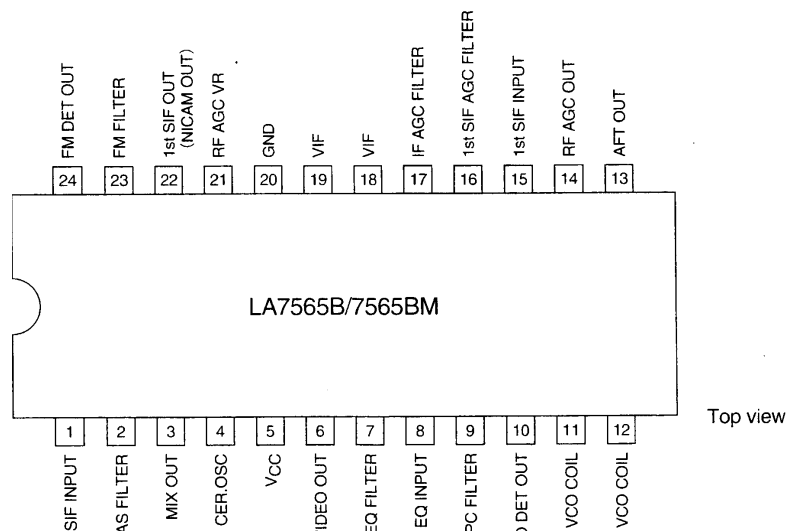

LA7565B, 7565BM

Pin Functions

| Pin No. | Pin | Pin function | Equivalent circuit |
|---------|------------------------|---|--------------------|
| 1 | SIF INPUT | <p>The input impedance is about 1 kΩ. If interference signals enter via this pin, those signals may cause buzz and buzz beat noise. (Here, signals such as video signals or chrominance signals are the main audio interference signals. The VIF carrier signal may also appear as interference.) The application printed circuit board pattern layout should be designed carefully to prevent interference from entering at this pin.</p> | |
| 2 | FM power supply filter | <p>The FM S/N ratio can be improved by inserting a filter in the FM detector bias line. The capacitor C1 should have a value of 0.47 μF or greater, and 1 μF is recommended. A 2-kΩ resistor must be inserted between pin 2 and ground if the FM detector is not used. This stops the FM detector VCO.</p> | |
| 3 4 | SIF converter | <p>Pin 3 is the SIF converter output. This signal is passed through a 6-MHz band-pass filter and input to the SIF circuit. A 200-Ω resistor is inserted in series with the emitter-follower output.</p> <p>Pin 4 is the SIF converter 500-kHz oscillator pin. Since the oscillator circuit includes an ALC circuit, the oscillator level is controlled at a fixed, relatively low level. An external 10-kΩ resistor must be inserted between pin 3 and ground if this circuit is not used. Attaching this external resistor stops the 500-kHz oscillator and the converter can be used as an amplifier.</p> | |

Continued on next page.

LA7565B, 7565BM

Continued from preceding page.

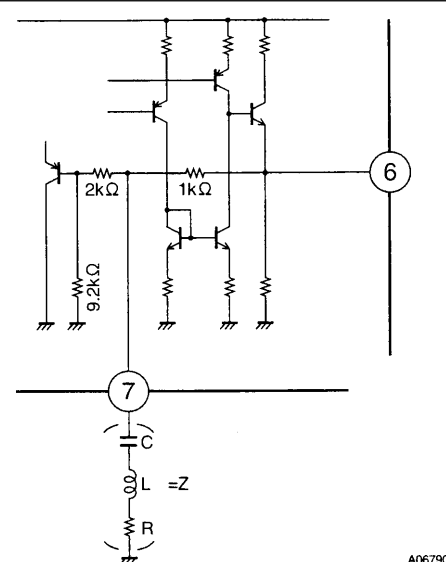
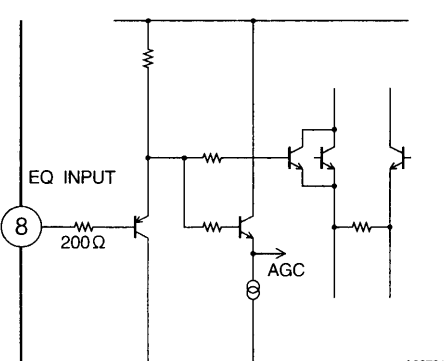
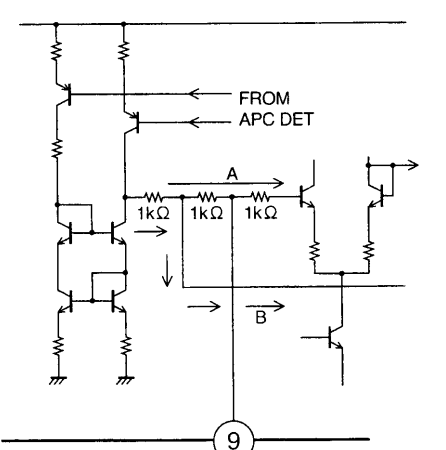
| Pin No. | Pin | Pin function | Equivalent circuit |
|-------------|-----------------|---|--|
| 5 | V _{CC} | V _{CC} and ground should be decoupled with as small a separation as possible. | |
| 6 7 8 | EQ amp | <p>Connections for the equalizer circuit. This circuit corrects the frequency characteristics of the video signal. Pin 17 is the equalizer amplifier input. A 1.5-V_{p-p} video signal is input and amplified to 2.0 V_{p-p} by the equalizer amplifier.</p> <p>The equalizer amplifier is designed as a voltage-follower amplifier with a gain of about 2.3 dB. When frequency characteristic correction is used, a capacitor, an inductor, and a resistor must be connected in series between pin 7 and ground.</p> <ul style="list-style-type: none"> Using the equalizer amplifier <p>If v_i is the input signal and v_o is the output signal, then: $R1/Z + 1 (v_i + v_{in}) = v_o \times G$</p> <p>Where, G: Gain of the voltage follower amplifier v_{in}: Imaginary short G: About 2.3 dB Assuming $v_{in} \approx 0$:</p> <p>Then, $AV = v_o/v_i = R1/Z + 1$.</p> <p>R1 is an IC internal resistor with a value of 1 kΩ. Simply select a Z according to the desired characteristics. However, since the equalizer amplifier is maximum at the Z resonance point, care is required to prevent distortion from occurring at that frequency.</p> |  <p style="text-align: right;">A06790</p>  <p style="text-align: right;">A06791</p> |
| 9 | APC filter | <p>PLL detector APC filter connection. The APC time constant is switched internally. When the PLL is locked, the VCO is controlled over the path marked A in the figure and the loop gain is lowered. When the PLL is unlocked and in weak field reception conditions, the VCO is controlled over the path marked B in the figure and the loop gain is increased.</p> <p>We recommend values of: R = between 150 and 390 Ω, and C = 0.47 μF for this APC filter.</p> |  <p style="text-align: right;">A06792</p> |

Continued on next page.

LA7565B, 7565BM

Continued from preceding page.

| Pin No. | Pin | Pin function | Equivalent circuit |
|----------|------------------------|---|--------------------|
| 10 | Composite video output | Output for the video signal that includes the SIF carrier. To acquire adequate drive capabilities, a resistor must be inserted between pin 10 and ground. $R \geq 300 \Omega$ | |
| 11 12 | VCO tank | This is the VCO tank circuit used for the video detector. Refer to the coil specifications provided separately for more information on the tank circuit. This VCO is a vector synthesis VCO. | |
| 13 | AFT output | The AFT center voltage is created by an external bleeder resistor. The AFT gain increases as the value of this external bleeder resistor is increased. Note that the value of this resistor must not exceed 390 kΩ. This circuit includes a control function that naturally brings the AFT voltage to its center value under weak field reception conditions. | |
| 14 | RF AGC output | This output controls the tuner RF AGC. There is a 200-Ω series protection resistor inserted in the emitter output. Determine the value of the external bleeder resistor based on the characteristics of the tuner used. | |

Continued on next page.

LA7565B, 7565BM

Continued from preceding page.

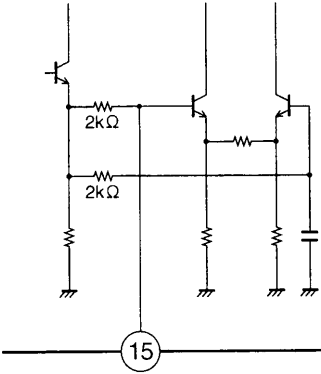
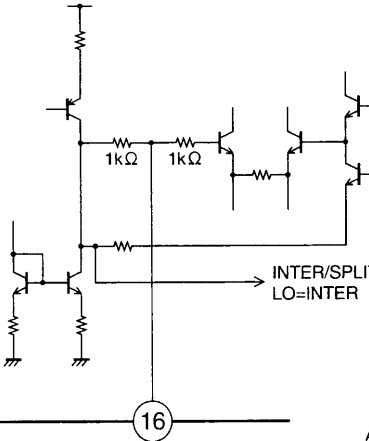
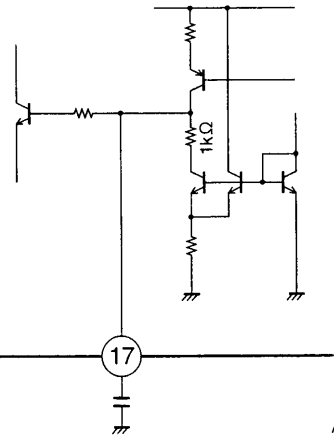
| Pin No. | Pin | Pin function | Equivalent circuit |
|---------|----------------------|---|--|
| 15 | First SIF input | <p>A DC cut capacitor must be used in the input to this circuit.</p> <ul style="list-style-type: none"> • When using a SAW filter: The first SIF sensitivity can be increased by inserting an inductor between the SAW filter and the IC input to counteract the SAW filter output capacitance and the IC input capacitance. • When used with an intercarrier sound system: This pin may be left open. |  <p style="text-align: right;">A06797</p> |
| 16 | First SIF AGC filter | <p>This IC adopts an average-value AGC technique. The first SIF conversion gain is about 30 dB, and the AGC range is 50 dB or greater. A capacitor of 0.01 μF is normally used as the filter connected to this pin.</p> <ul style="list-style-type: none"> • When used with an intercarrier sound system: This pin (pin 16) should be shorted to ground. The IC internal switch will operate and the intercarrier output will be connected to the SIF converter input. |  <p style="text-align: right;">A06798</p> |
| 17 | IF AGC filter | <p>The internal AGC peak detector output signal is converted to the AGC voltage at pin 17. Additionally, a second AGC filter (a lag-lead filter) used to create dual time constants internally to the IC is built in.</p> <p>A 0.022-μF external capacitor is used. The value of this capacitor must be adjusted based on an analysis of the sag, AGC speed, and other aspects.</p> |  <p style="text-align: right;">A06799</p> |

Continued on next page.

LA7565B, 7565BM

Continued from preceding page.

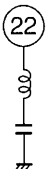
| Pin No. | Pin | Pin function | Equivalent circuit |
|----------|------------------|---|--------------------|
| 18 19 | VIF input | <p>Input for the VIF amplifier. The input circuit creates an averaged input and has an input impedance determined by the following resistor and capacitor values. $R = 1.5\text{ k}\Omega$ $C = 3\text{ pF}$</p> | |
| 20 | GND | | |
| 21 | RF AGC VR | <p>RF AGC VR connection. This pin sets the tuner RF AGC operating point. Also, the FM output and the video output can be muted at the same time by shorting this pin to ground.</p> | |
| 22 | First SIF output | <p>A 600-Ω resistor is attached to the emitter follower internally for signal output. When an intercarrier sound system is used, the buzz characteristics can be improved by forming a chrominance carrier trap on this pin.</p> <div style="text-align: center;">  <p>← Construct a chrominance carrier trap here.</p> </div> <p style="text-align: center;">A06802</p> | |

Continued on next page.

LA7565B, 7565BM

Continued from preceding page.

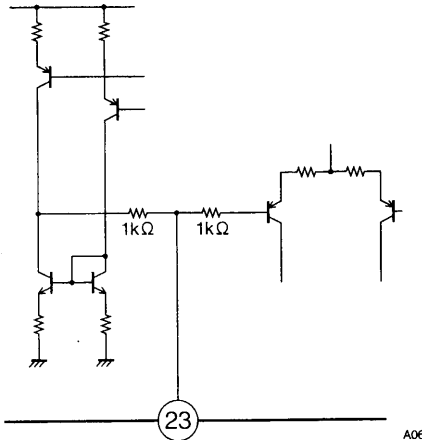
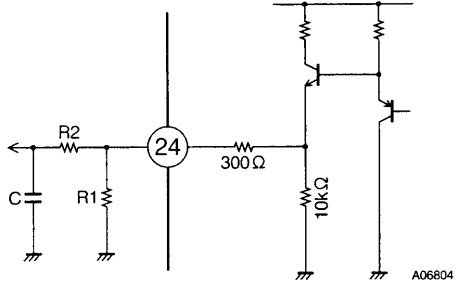
| Pin No. | Pin | Pin function | Equivalent circuit |
|---------|--------------------|---|---|
| 23 | FM filter | <p>Connection for a filter used to hold the FM detector output at a fixed DC voltage. Normally, a 1-μF electrolytic capacitor is used. If the low area (around 50 Hz) frequency characteristics are seen as a problem, this capacitance should be increased.</p> |  |
| 24 | FM detector output | <p>Audio FM detector output. A 200-Ω resistor is inserted in series after the emitter follower.</p> <ul style="list-style-type: none"> In applications that support stereo: In applications that input to a stereo decoder, the reduced input impedance can cause distortion in the L-R signal. This may degrade the stereo characteristics. If this is a problem add the resistor R1 between pin 24 and ground. $R1 \geq 5.1 \text{ k}\Omega$ In applications that support mono: Attach an external de-emphasis circuit with the following time constant. $t = CR2$ |  |

Notes on Sanyo SAW Filters

There are two types of SAW filters, which differ in the piezoelectric substrate material, as follows:

1. Lithium tantalate (LiTaO₃) SAW filter

TSF11 □ □ Japan

TSF12 □ □ US

Although lithium tantalate SAW filters have the low temperature coefficient of $-18 \text{ ppm}/^\circ\text{C}$, they suffer from a large insertion loss. However, it is possible, at the cost of increasing the number of external components required, to minimize this insertion loss by using a matching circuit consisting of coils and other components at the SAW filter output. At the same time as minimizing insertion loss, this technique also allows the frequency characteristics, level, and other aspects to be varied, and thus provides increased circuit design flexibility. Also, since the SAW filter reflected wave level is minimal, the circuit can be designed with a small in-band ripple level.

2. Lithium niobate (LiNbO₃) SAW filter

TSF52 □ □ US

TSF53 □ □ PAL

Although lithium niobate SAW filters have the high temperature coefficient of $-72 \text{ ppm}/^\circ\text{C}$, they feature an insertion loss about 10 dB lower than that of lithium tantalate SAW filters. Accordingly, there is no need for a matching circuit at the SAW filter output. Although the in-band ripple is somewhat larger than with lithium tantalate SAW filters, since they have a low impedance and a small field slew, they are relatively immune to influences from peripheral circuit components and the geometry of the printed circuit board pattern. This allows stable out-of-band trap characteristics to be acquired. Due to the above considerations, lithium tantalate SAW filters are used in applications for the US and Japan that have a high IF frequency, and lithium niobate SAW filters are used in PAL and US applications that have a low IF frequency.

Notes on SAW Filter Matching

In SAW filter input circuit matching, rather than matching the IF frequency, flatter video band characteristics can be acquired by designing the tuning point to be in the vicinity of the audio carrier rather than near the chrominance carrier. The situation shown in figure on the right makes it easier to acquire flat band characteristics than that in figure on the left.

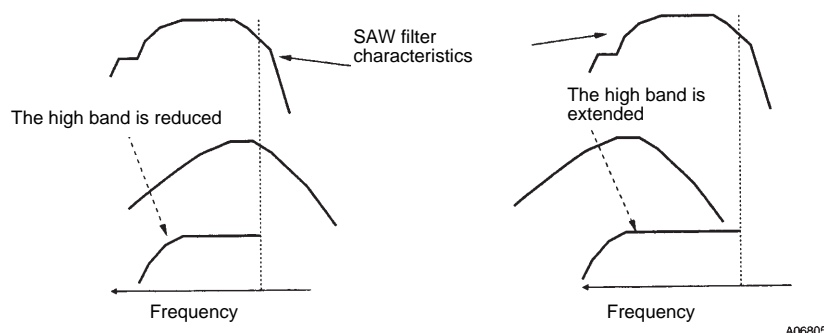

With the tuning set to the IF frequency

With the tuning set to the vicinity of S and C

LA7565B, 7565BM

Coil Specifications

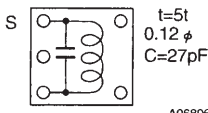
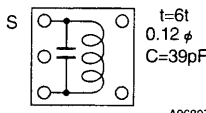
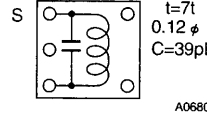
| | JAPAN f = 58.75 MHz | US f = 45.75 MHz | PAL f = 38.9 MHz |
|--------------------|--|---|--|
| VCO coil |  <p style="text-align: center;">A06806</p> <p style="text-align: center;">Test production no. 16991B Tokyo Parts Industry Co., Ltd.</p> |  <p style="text-align: center;">A06807</p> <p style="text-align: center;">Test production no. 16991B Tokyo Parts Industry Co., Ltd.</p> |  <p style="text-align: center;">A06808</p> <p style="text-align: center;">Test production no. 16991B Tokyo Parts Industry Co., Ltd.</p> |
| SAW filter (SPLIT) | <p style="text-align: center;">Picture TSF1137U</p> <p style="text-align: center;">Sound</p> | <p style="text-align: center;">Picture TSF1241</p> <p style="text-align: center;">Sound</p> | <p style="text-align: center;">Picture TSF5315</p> <p style="text-align: center;">Sound</p> |
| SAW filter (INTER) | | <p style="text-align: center;">TSF5220 TSF5221</p> | <p style="text-align: center;">TSF5321 TSF5344</p> |

Tokyo Parts Industry Co., Ltd.
236 Hinode-cho, Iseaki city, Gunma Prefecture, Japan TEL: +81-270-23-3731

Notes on VCO Tank Circuits

1. Built-in capacitor VCO tank circuits

When the power is turned on, the heat generated by the IC is transmitted through the printed circuit board to the VCO transformer. At this point, the VCO coil frame functions as a heat sink and the IC heat is dissipated. As a result, it becomes more difficult to transmit heat to the VCO transformer's built-in capacitor, and the influence of drift at power on is reduced. Therefore, it suffices to design the circuit so that the coil and capacitor thermal characteristics cancel. Ideally, it is better to use a coil with a core material that has low temperature coefficient characteristics.

2. External capacitor VCO tank circuits

When an external capacitor is used, heat generated by the IC is transmitted through the printed circuit board directly to the VCO tank circuit external capacitor. While this capacitor is heated relatively early after the power is turned on, the coil is not influenced as much by this heat, and as a result the power-on drift is increased. Accordingly, a coil whose core material has low temperature coefficient characteristics must be used. It is also desirable to use a capacitor with similarly low temperature coefficient characteristics.

Note: Applications that use an external capacitor here must use a chip capacitor. If an ordinary capacitor is used, problems such as the oscillator frequency changing with the capacitor orientation may occur.

- No products described or contained herein are intended for use in surgical implants, life-support systems, aerospace equipment, nuclear power control systems, vehicles, disaster/crime-prevention equipment and the like, the failure of which may directly or indirectly cause injury, death or property loss.
- Anyone purchasing any products described or contained herein for an above-mentioned use shall:
 - ① Accept full responsibility and indemnify and defend SANYO ELECTRIC CO., LTD., its affiliates, subsidiaries and distributors and all their officers and employees, jointly and severally, against any and all claims and litigation and all damages, cost and expenses associated with such use:
 - ② Not impose any responsibility for any fault or negligence which may be cited in any such claim or litigation on SANYO ELECTRIC CO., LTD., its affiliates, subsidiaries and distributors or any of their officers and employees jointly or severally.
- Information (including circuit diagrams and circuit parameters) herein is for example only; it is not guaranteed for volume production. SANYO believes information herein is accurate and reliable, but no guarantees are made or implied regarding its use or any infringements of intellectual property rights or other rights of third parties.

This catalog provides information as of August, 1997. Specifications and information herein are subject to change without notice.