



LB1412M

Level Meter for 12 LEDs

Functions and Features

- Bar-shaped display of input level by means of 12 LEDs.
- High-order 5 dots with peak hold.
- Built-in oscillator for peak hold reset. Requires 1pce each of external C, R. Uses either oscillator at the time of stereo operation. Also capable of resetting manually.
- Capable of constant-current driving low-order 7 dots (green LED). Constant-current value variable with an external resistor.
- Lower current drain available by connecting green LEDs in series.
- Built-in input amplifier.
- Requires no other light-up level adjustment than adjustment for 0 dB. D1 error: Within ± 3 dB of 20 dB
- Supply voltage range: 10 to 16 V

Package Dimensions

unit : mm

3045B-MFP24

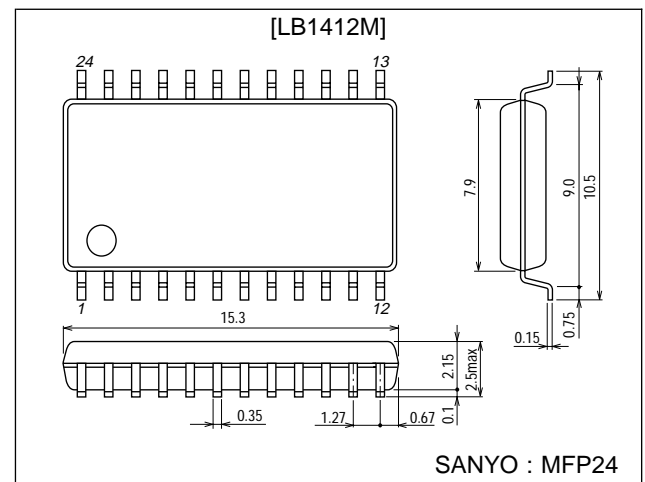

Specifications

Absolute Maximum Ratings at $T_a = 25^\circ\text{C}$

Parameter	Symbol	Conditions	Ratings	Unit
Maximum supply voltage	V_{CC} max	Pin 16	-0.3 to +18	V
Output current	I_{OL}	Pins 2 to 6: D8 to D12, output on	30	mA
Allowable power dissipation	P_d max	$T_a = 60^\circ\text{C}$	380	mW
Operating temperature	T_{opr}		-30 to +75	$^\circ\text{C}$
Storage temperature	T_{stg}		-40 to +125	$^\circ\text{C}$

Allowable Operating Range at $T_a = 25^\circ\text{C}$

Parameter	Symbol	Conditions	Ratings	Unit
Supply voltage	V_{CC}		10 to 16	V

■ Any and all SANYO products described or contained herein do not have specifications that can handle applications that require extremely high levels of reliability, such as life-support systems, aircraft's control systems, or other applications whose failure can be reasonably expected to result in serious physical and/or material damage. Consult with your SANYO representative nearest you before using any SANYO products described or contained herein in such applications.

■ SANYO assumes no responsibility for equipment failures that result from using products at values that exceed, even momentarily, rated values (such as maximum ratings, operating condition ranges, or other parameters) listed in products specifications of any and all SANYO products described or contained herein.

SANYO Electric Co.,Ltd. Semiconductor Company

TOKYO OFFICE Tokyo Bldg., 1-10, 1 Chome, Ueno, Taito-ku, TOKYO, 110-8534 JAPAN

53096HA(II)/9087KI/9134KI,TS No.1593-1/5

LB1412M

Electrical Characteristics at Ta = 25°C, VCC = 12 V

Parameter		Symbol	Pin No.	Conditions	min	typ	max	Unit
Input bias current	Amp (1)	I _{BIN1}	8		-3	-0.2	0	μA
Output saturation voltage	Amp (1)	V _{OH01}	9	Pins 9, 10 short	10.5	11.2	11.6	V
	Amp (1)	V _{OL01}	9	Pins 9, 10 short	1.0	1.5	2.0	V
Voltage gain	Amp (1)	V _{GA1}			30	100		dB
Input resistance	Amp (2)	R _{IN2}	10		8	12	16	kΩ
Load resistance	Amp (2)	R _{O2}	11		35	50	65	kΩ
Output current	Amp (2)	I _{OL02}	11		3	6	12	mA
Voltage gain	Amp (2)	V _{GA2}			1.8	2.0	2.2	times
Output current		I _{OL}	17, 21	D1, D5: 3 kΩ across V _Z and I _{LED}	13	17	20	mA
Output saturation voltage		V _{sat}	18, 19, 20, 22, 23	D2 to D4, D6 to D7: output transistor on across V _Z and I _{LED}		1.0	1.3	V
		V _{sat}	2 to 6	D8 to D12: I _{OLD1} to D5 = 30 mA		1.5	2.0	V
Output leak current		I _{off}	17, 21	D1, D5: output transistor off	0		30	μA
		I _{off}	2 to 6	D8 to D12: output transistor off	0		30	μA
Comparator level	D8	V _{THD8}	2	D8: Voltage to turn on D8 by applying DC voltage across V _Z and I _{N2}	-0.625	-0.55	-0.465	V
	D1	G _{D1}	17	D8 light-up level: 0 dB	-23	-20	-17	dB
	D2	G _{D2}	18	D8 light-up level: 0 dB	-17	-15	-13	dB
	D3	G _{D3}	19	D8 light-up level: 0 dB	-12	-10	-8	dB
	D4	G _{D4}	20	D8 light-up level: 0 dB	-8	-7	-6	dB
	D5	G _{D5}	21	D8 light-up level: 0 dB	-6	-5	-4	dB
	D6	G _{D6}	22	D8 light-up level: 0 dB	-4	-3	-2	dB
	D7	G _{D7}	23	D8 light-up level: 0 dB	-1.5	-1	-0.5	dB
	D9	G _{D9}	3	D8 light-up level: 0 dB	0.5	1	1.5	dB
	D10	G _{D10}	4	D8 light-up level: 0 dB	2	3	4	dB
	D11	G _{D11}	5	D8 light-up level: 0 dB	4	5	6	dB
D12	G _{D12}	6	D8 light-up level: 0 dB	7	8	9	dB	
Reference voltage		V _Z	13	3 kΩ across V _Z and I _{LED}	5.6	6.3	6.8	V
R pin flow-out current		I _{OLR}	12	V _R = 0 V, OSC pin open	-0.6	-0.3	-0.1	mA
R pin voltage		V _R	12	OSC pin open	0.4	0.7	0.9	V
Oscillation frequency		f _{OSC}	14	1 MΩ, 2.2 μF across V _{CC} and V _Z	1.5	2	2.5	s
Current drain		I _{CC}	16	3 kΩ across V _Z and I _{LED} , all D outputs off		9	15	mA

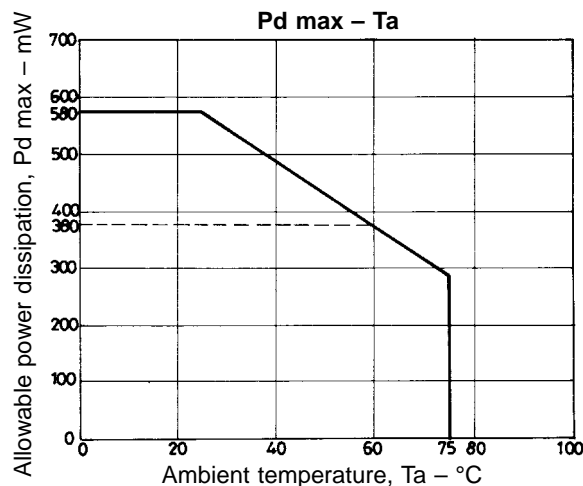

LB1412M

Pin Assignment

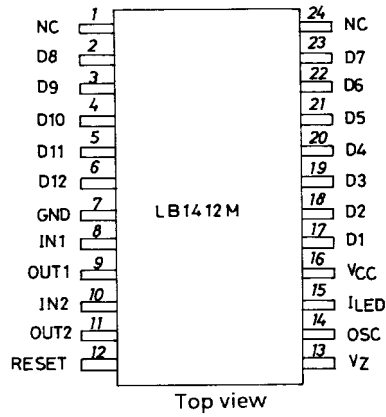

Equivalent Circuit Block Diagram

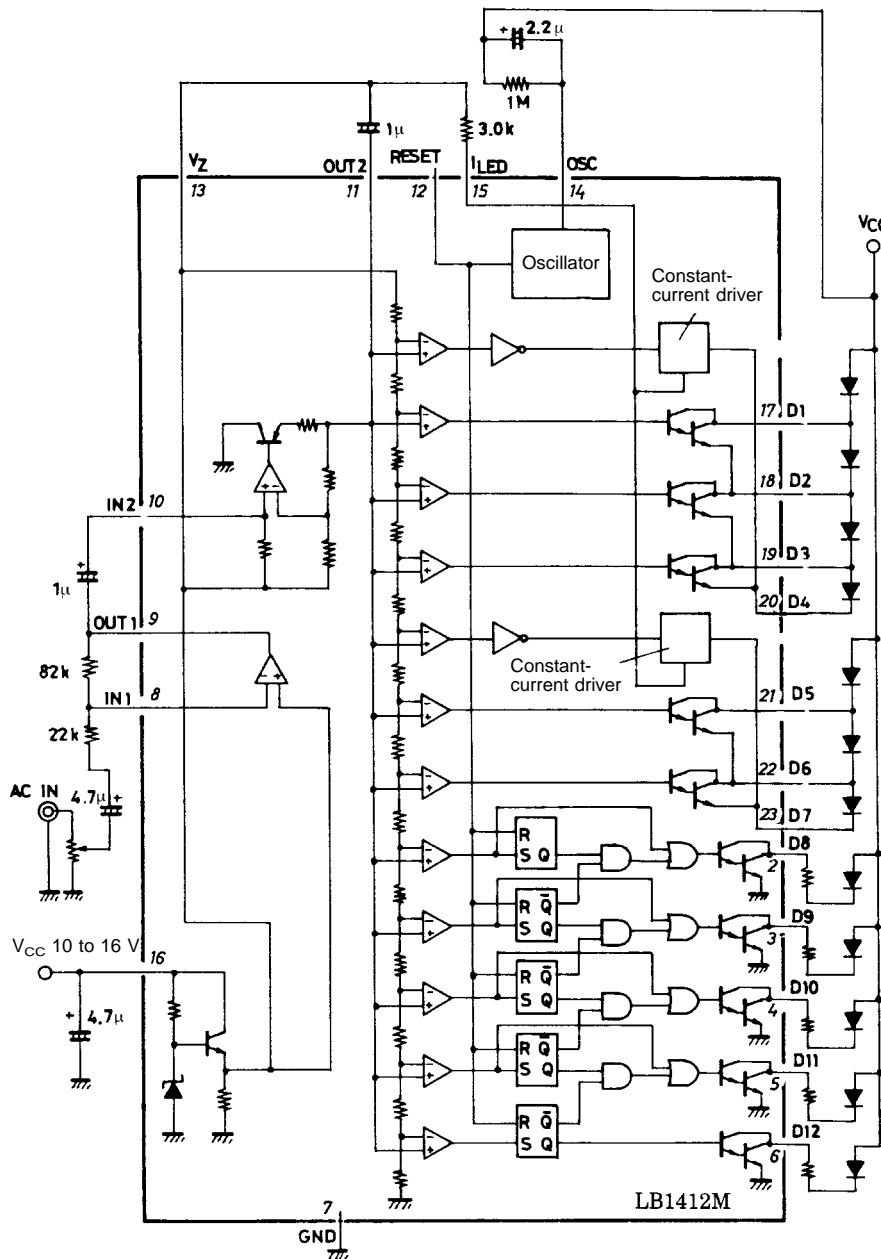

Unit (resistance: Ω, capacitance: F)

Sample Application Circuit

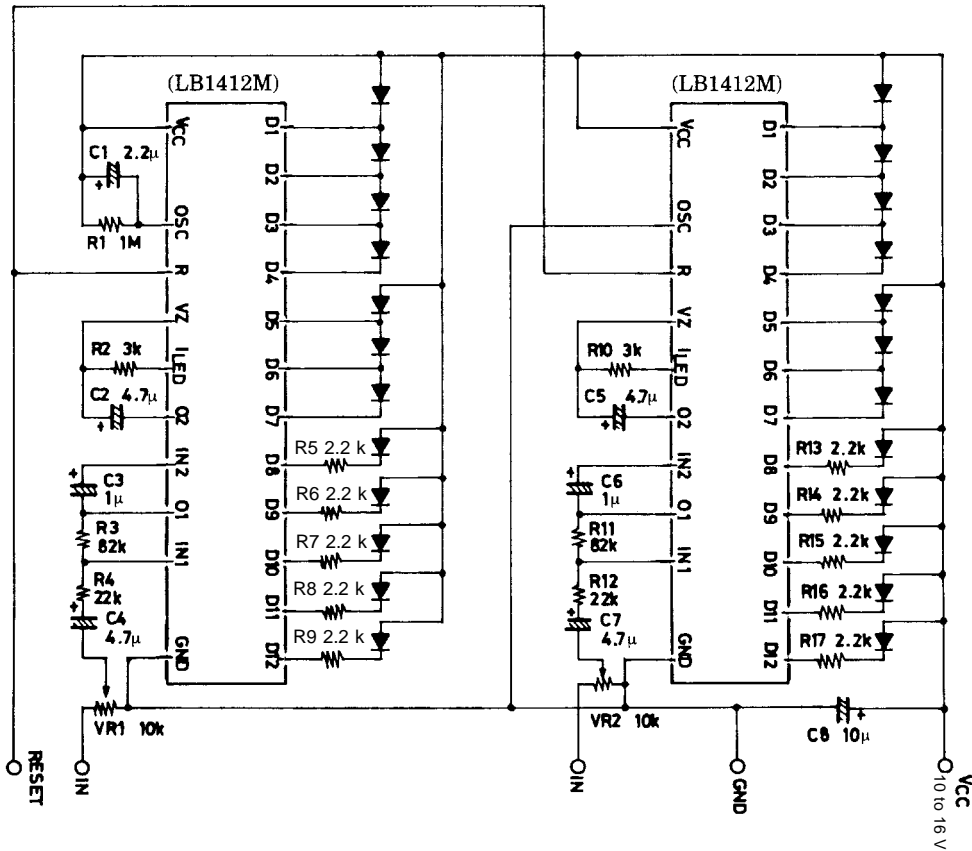

Unit (resistance: Ω, capacitance: F)

Note : Input signal of approximately 110 mVrms causes D8 (0 dB display) to light.

For sample application circuit :

1. The LB1412M consists of the following blocks.
 - Input amp 1: Amplification of input signal, variable with external constants
 - Input amp 2: Amplification of signal (fixed, double), detection of signal
 - Reference voltage : Reference voltage of comparator, constant-current drive of LED
 - Comparator : Comparison of input voltage
 - LED driver : LED drive, D1 to D7: Constant-current drive
 - Peak hold circuit : Hold of highest-order point of high-order 5 points (D8 to D12)
 - Oscillator for peak hold reset : Peak hold circuit reset
2. Description of constants of each block
 - 2-1 R3, R4 (R11, R12)
The gain of amp1 depends on R3, R4. Gain of amp 1 = R3/R4 times. The gain of amp1 must not exceed 4 times (12 dB). R3 + R4 ≐ 100 kΩ (C4 = 4.7 µF).
 - 2-2 C2, C3 (C5, C6)
C3 is for coupling amp 1 with amp 2 and its value is 1 µF. C2 is for controlling the time to turn off LED.
 - 2-3 R2 (R10)
The current of LEDs connected to D1 to D7 depends on R2. The current is stabilized to be approximately 17 mA at R2 = 3 kΩ and approximately 11 mA at R2 = 4.7 kΩ.
 - 2-4 R5 to R9 (R13 to R17)
The current of LEDs connected to D8 to D12 depends on these resistors. D8 to D12 pins are collectors of Darlington transistors.

$$I_{D8 \text{ to } D12} = \frac{V_{CC} - V_{sat \text{ D8 to D12}} - V_{FLED}}{R5 \text{ to } 9} \cong \frac{V_{CC} - 3.5 \text{ V}}{R5 \text{ to } 9}$$

$I_{D8 \text{ to } D12}$ is approximately 4 mA at R5 to 9 = 2.2 kΩ.

LB1412M

2-5 Reset pin (Pin 12)

When the reset pin is open, peak hold of D8 to D12 occurs. When the reset pin is connected to GND, reset occurs. Connecting the reset pin to GND causes no peak hold.

2-6 C1, R1

The oscillation cycle of oscillator depends on the product of C1 and R1. The oscillation cycle at $C1 = 2.2 \mu\text{F}$, $R1 = 1 \text{M}\Omega$ is approximately 2 seconds. However, if an electrolytic capacitor is used for C1, the actual capacitance differs from the marked value.

2-7 Reduction in number of parts

R3, R4, VR1 are substituted by one VR.

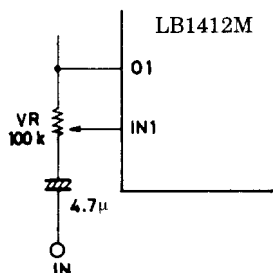

Unit (resistance: Ω , capacitance: F)

- Specifications of any and all SANYO products described or contained herein stipulate the performance, characteristics, and functions of the described products in the independent state, and are not guarantees of the performance, characteristics, and functions of the described products as mounted in the customer's products or equipment. To verify symptoms and states that cannot be evaluated in an independent device, the customer should always evaluate and test devices mounted in the customer's products or equipment.
- SANYO Electric Co., Ltd. strives to supply high-quality high-reliability products. However, any and all semiconductor products fail with some probability. It is possible that these probabilistic failures could give rise to accidents or events that could endanger human lives, that could give rise to smoke or fire, or that could cause damage to other property. When designing equipment, adopt safety measures so that these kinds of accidents or events cannot occur. Such measures include but are not limited to protective circuits and error prevention circuits for safe design, redundant design, and structural design.
- In the event that any or all SANYO products (including technical data, services) described or contained herein are controlled under any of applicable local export control laws and regulations, such products must not be exported without obtaining the export license from the authorities concerned in accordance with the above law.
- No part of this publication may be reproduced or transmitted in any form or by any means, electronic or mechanical, including photocopying and recording, or any information storage or retrieval system, or otherwise, without the prior written permission of SANYO Electric Co., Ltd.
- Any and all information described or contained herein are subject to change without notice due to product/technology improvement, etc. When designing equipment, refer to the "Delivery Specification" for the SANYO product that you intend to use.
- Information (including circuit diagrams and circuit parameters) herein is for example only; it is not guaranteed for volume production. SANYO believes information herein is accurate and reliable, but no guarantees are made or implied regarding its use or any infringements of intellectual property rights or other rights of third parties.

This catalog provides information as of May, 1996. Specifications and information herein are subject to change without notice.