



LB1695D

Three-Phase Brushless Motor Driver for DC Fan

Overview

The LB1695D is a driver IC for 3-phase brushless DC fan motors such as used in water heaters and other domestic electrical appliances.

Features

- Three-phase brushless motor driver
- Withstand voltage 45V, output current 2A
- Built-in current limiter
- Built-in low-voltage protection circuit
- Built-in thermal shutdown circuit
- Built-in Hall amplifier with hysteresis
- FG output function

Package Dimensions

unit: mm

3037A-DIP20H

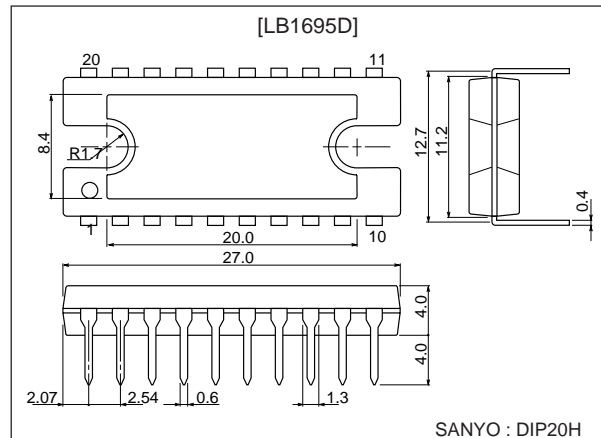

Specifications

Absolute Maximum Ratings at Ta = 25°C

Parameter	Symbol	Conditions	Ratings	Unit
Maximum supply voltage	V _{CC} max		10	V
	V _M max		45	V
Maximum output current	I _O max		2.0	A
Allowable power dissipation	Pd max1	IC only	3	W
	Pd max2	With an arbitrary large heat sink	20	W
Operating temperature	T _{opr}		-20 to +100	°C
Storage temperature	T _{stg}		-55 to +150	°C

Allowable Operating Ranges at Ta = 25°C

Parameter	Symbol	Conditions	Ratings	Unit	
Power supply voltage range	V _{CC}		4.5 to 9.0	V	
	V _M		5 to 42	V	
Power supply startup voltage slew rate	ΔV _{CC} /Δt	V _{CC} = V _{LVSD} (OFF) point	*1	Up to 0.04	V / μs
	ΔV _M /Δt	V _M = 0V point	*1	Up to 0.16	V / μs

*1 After power-on, if the power supply voltage rise is fast, there may be some feedthrough current in the output.

■ Any and all SANYO products described or contained herein do not have specifications that can handle applications that require extremely high levels of reliability, such as life-support systems, aircraft's control systems, or other applications whose failure can be reasonably expected to result in serious physical and/or material damage. Consult with your SANYO representative nearest you before using any SANYO products described or contained herein in such applications.

■ SANYO assumes no responsibility for equipment failures that result from using products at values that exceed, even momentarily, rated values (such as maximum ratings, operating condition ranges, or other parameters) listed in products specifications of any and all SANYO products described or contained herein.

LB1695D

Electrical Characteristics at $T_a = 25^\circ\text{C}$, $V_{CC} = 5\text{V}$, $V_M = 30\text{V}$

Parameter	Symbol	Conditions	Ratings			Unit
			min	typ	max	
Power supply current	I_{CC}	Forward		13	19	mA
Output saturation voltage	$V_{O\text{sat}1}$	$I_O = 0.5\text{A } V_O \text{ (sink) } + V_O \text{ (source)}$		1.8	2.4	V
	$V_{O\text{sat}2}$	$I_O = 1.0\text{A } V_O \text{ (sink) } + V_O \text{ (source)}$		2.1	2.8	V
Output leakage current	$I_{O \text{ leak}}$				100	μA
[Hall amplifier]						
Input bias current	I_{HB}			1	4	μA
Common mode input voltage range	V_{ICM}		1.5		$V_{CC}-1.8$	V
Hysteresis width	ΔV_{IN}		21	30	37	mV
Input voltage L -> H	V_{SLH}		5	15	25	mV
Input voltage H -> L	V_{SHL}		-25	-15	-5	mV
[FG pin (Speed pulse output)]						
Output Low level voltage	V_{FGL}	$I_{FG} = 5 \text{ mA}$			0.4	V
Pull-up resistor value	R_{FG}		7.5	10	12.5	k Ω
[Forward/reverse operation]						
Forward	V_{FR1}		0		0.8	V
Reverse	V_{FR2}		4.2		V_{CC}	V
[Current limiter operation]						
Limiter	V_{RF}		0.42	0.5	0.6	V
[Thermal shutdown operation]						
Operating temperature	TSD	Design target value	150	180		$^\circ\text{C}$
Hysteresis width	ΔTSD	Design target value		40		$^\circ\text{C}$
[Low-voltage protection circuit operation]						
Operating voltage	V_{LVSD}		3.5	3.8	4.1	V
Release voltage	$V_{LVSD}(\text{OFF})$			4.3	4.5	V
Hysteresis width	ΔV_{LVSD}		0.4	0.5	0.6	V
[C pin]						
Charge current	I_{CL}	$R = 33 \text{ k}\Omega$	30	40	50	μA
Discharge current	I_{CH}	$R = 33 \text{ k}\Omega$	90	120	150	μA
Charge start voltage	V_{CL}	$R = 33 \text{ k}\Omega$	0.3	0.4	0.5	V
Discharge start voltage	V_{CH}	$R = 33 \text{ k}\Omega$	1.5	2.0	2.5	V
Output current ignore time	t_{sm}	$R = 33 \text{ k}\Omega$, $C = 4700 \text{ pF}$	58	68	78	μs
Output off time	t_{so}	$R = 33 \text{ k}\Omega$, $C = 4700 \text{ pF}$	164	193	222	μs

LB1695D

Truth Table

	Input			Forward/reverse control	Output	FG output	
	IN1	IN2	IN3	F/R	Source -> Sink	FG1	FG2
1	H	L	H	L	OUT2 -> OUT1	L	L
				H	OUT1 -> OUT2		
2	H	L	L	L	OUT3 -> OUT1	L	H
				H	OUT1 -> OUT3		
3	H	H	L	L	OUT3 -> OUT2	L	L
				H	OUT2 -> OUT3		
4	L	H	L	L	OUT1 -> OUT2	H	H
				H	OUT2 -> OUT1		
5	L	H	H	L	OUT1 -> OUT3	H	L
				H	OUT3 -> OUT1		
6	L	L	H	L	OUT2 -> OUT3	H	H
				H	OUT3 -> OUT2		

F/R

FG output

Forward L 0.0 to 0.8V
Reverse H 4.2 to 5.0V

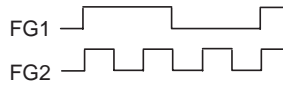

Block Diagram and Peripheral Circuitry

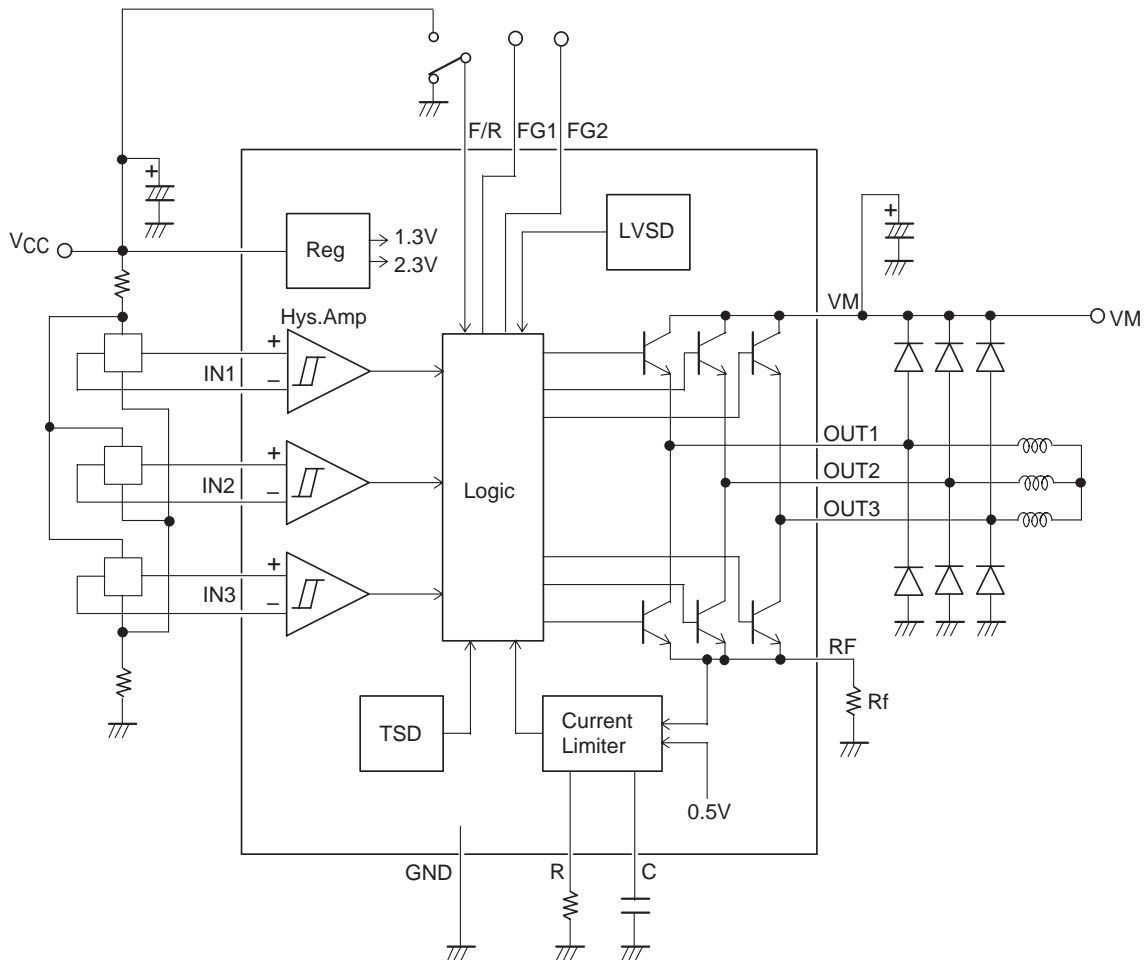

LB1695D

Pin Description

Pin name	Pin number	Function
VCC	1	Power supply pin for blocks except output
R	2	C pin charge/discharge current set pin
C	3	Setting pin for current limiter output off time and output current ignore time
NC	4, 9	May be used for wiring
OUT1	5	Output pin 1
OUT2	6	Output pin 2
OUT3	7	Output pin 3
RF	8	Output current detection pin. Insert a resistor (Rf) between this pin and ground. The output current will be limited to the value determined by V_{RF}/R_f (output current limiter).
VM	10	Power supply pin for output
GND	11	Ground for blocks except output Lowest electrical potential of output transistors is voltage at RF pin.
F/R	12	Forward/reverse control pin
IN1+, IN1-	17, 18	Hall input pin Logic High refers to IN+ > IN-
IN2+, IN2-	15, 16	Hall input pin Logic High refers to IN+ > IN-
IN3+, IN3-	13, 14	Hall input pin Logic High refers to IN+ > IN-
FG1	20	Speed pulse output pin 1 with built-in pull-up resistor
FG2	19	Speed pulse output pin 2 with built-in pull-up resistor

Pin Assignment

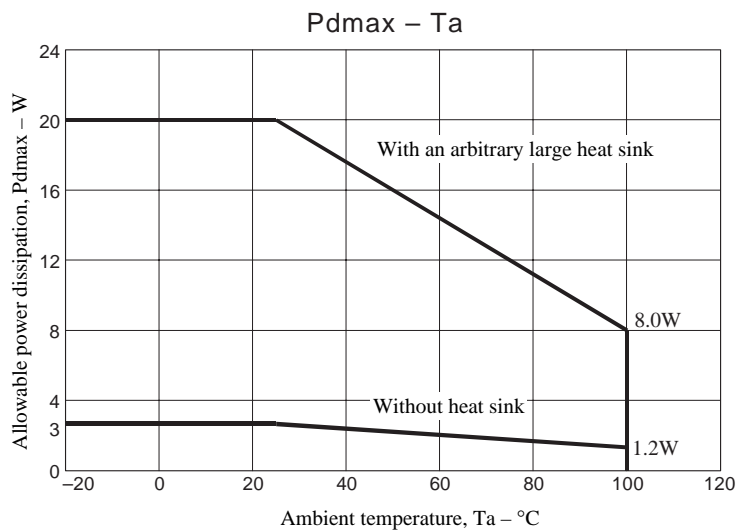
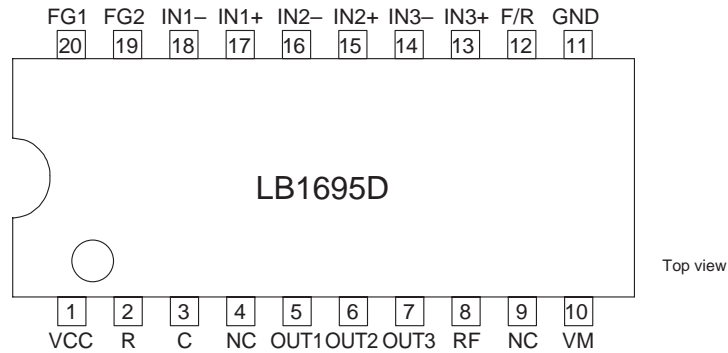

LB1695D

Pin Equivalent Circuit

Pin number	Pin name	Pin voltage	Equivalent circuit
3 2	C R		
5 6 7 8 10	OUT1 OUT2 OUT3 RF VM		
12	F/R	0.0V min V_{CC} max	

Continued on next page

LB1695D

Continued from preceding page

Pin number	Pin name	Pin voltage	Equivalent circuit
17 18 15 16 13 14	IN1+ IN1- IN2+ IN2- IN3+ IN3-	1.5V min $V_{CC}-1.8V$ max	
20 19	FG1 FG2		

Description of the LB1695D

1. Hall input circuit

The Hall input circuit is a differential amplifier with a hysteresis of 30 mV (typ.). The operating DC level must be within the common mode input voltage range (1.5V to $V_{CC} - 1.8\text{V}$). To prevent noise and other adverse influences, the input level should be at least 3 times the hysteresis (120 to 160 mVp-p). If noise evaluation at the Hall input shows a problem, a noise-canceling capacitor (about 0.01 μF) should be connected across the Hall input IN+ and IN- pins.

2. Protection circuits

2-1. Low voltage protection circuit

When the V_{CC} voltage falls below a certain level (V_{LVSD}), the low voltage protection circuit cuts off the sink-side output transistors to prevent malfunction caused by a V_{CC} voltage drop.

2-2. Thermal shutdown circuit

When the junction temperature rises above a certain value (TSD), the thermal shutdown circuit cuts off the sink-side output transistors to prevent IC damage due to overheating. Design the application heat characteristics so that the protection circuit will not be triggered under normal circumstances.

3. FG output circuit

The Hall input signal at IN1, IN2, and IN3 is synthesized and subject to waveform shaping before appearing at this output. The signal at FG1 has the same frequency as the Hall input, and the signal at FG2 has a frequency that is three times higher than the Hall input.

4. Forward/Reverse control circuit

This IC is designed under the assumption that forward/reverse (F/R) switching will not be carried out while the motor is running. If switching is carried out while the motor is running, a feedthrough current flows in the output and a problem will be caused regarding ASO. F/R switching should be carried out while the V_M power supply is off (motor is stopped).

5. V_{CC} , V_M power supply

When the power supply voltage (V_{CC} , V_M) rises very quickly at power-on, a feedthrough current may flow in the output and a problem will be caused regarding ASO. The power supply rise speed should be kept below $\Delta V_{CC}/\Delta t = 0.04\text{V}/\mu\text{S}$ and $\Delta V_M/\Delta t = 0.16\text{V}/\mu\text{S}$. For the power-up sequence, V_{CC} should be turned on before V_M .

The sequence at power-down should be V_M first, and then motor stop, and then V_{CC} . With some motors, if V_{CC} is switched off immediately after V_M , while the motor is still rotating due to inertia, the V_M voltage may rise and exceed the withstand voltage.

6. Power supply stabilizing capacitors

If the V_{CC} line fluctuates drastically, the low-voltage protection circuit may be activated by mistake, or other malfunctions may occur. The V_{CC} line should therefore be stabilized by connecting a capacitor of at least several μF between V_{CC} and ground. Because a large switching current flows in the V_M line, wiring inductance and other factors can lead to V_M voltage fluctuations. As the GND line also fluctuates, the V_M line must be stabilized by connecting a capacitor of at least several μF between V_M and ground, to prevent malfunction or exceeding the withstand voltage. Especially when long wiring runs (V_M , V_{CC} , GND) are used, sufficient capacitance should be provided to ensure power supply stability.

Continued from preceding page

7. Current limiter circuit

The current limiter circuit cuts off the sink-side output transistors when the output current reaches a preset value (limiter value). This limits the output current peak value.

For detection of output current, the RF pin is used. By connecting the resistance Rf between the RF pin and ground, the output current can be detected as a voltage. When the RF pin voltage reaches 0.5V (typ.), the current limiter is activated. This limits the output current to the value determined by 0.5/Rf.

7-1. Output off time

When the current limiter circuit was triggered and has switched off the sink-side output transistors, it will turn them on again after a preset interval (power off time). By switching the output in this way, the current limiter circuit of the LB1695D reduces the likelihood of ASO problems as compared to current limiters using the non-saturation output principle.

The output off time is determined by the charge time for the capacitance C connected to the C pin. When the limiter is triggered, C starts to charge, and the time required for the C voltage to reach 2V (typ.) is the output off time. When C was charged to 2V, the sink-side output is turned on again. The charge current for C is constant-current and is determined by the resistance R connected to the R pin. The C charge current I_{CL} and the output off time t_{off} are calculated according to the following equations.

$$\begin{aligned} I_{CL} &\doteq 1.3/R \quad (R \text{ should be between } 13 \text{ k}\Omega \text{ to } 100 \text{ k}\Omega) \\ t_{off} &\doteq C/I_{CL} \times 2.0 \\ &\doteq 1.53 \times R \times C \end{aligned}$$

7-2. Output current ignore time

While the sink-side output is turned off by the current limiter, a regenerative current flows in the upper side regenerative current absorption diode connected externally. When the output off time has elapsed and the sink-side output is turned on again, a momentary reverse current flows in the external diode (due to the reverse recovery time of the diode), which causes a limiter-value current to flow momentarily in the output. If this triggers the current limiter again, the output will be turned off, which lowers the average current and causes a reduction in motor torque for example during startup. To prevent this, the circuit is designed not to monitor the output current for a certain period after the sink-side output were turned off and on again. This is called the output current ignore time.

The output current ignore time is determined by the discharge time of the capacitance C connected to the C pin. After the current limiter was triggered and C was charged to 2V, the discharge process starts. The time required to discharge to a voltage of 0.4V (typ.) is the output ignore time. The discharge current for C is constant-current and is about 3 times the charge current (I_{CL}). Therefore the output current ignore time is about 1/3 of the output off time.

The C discharge current I_{CH} and the output current ignore time t_{sm} are calculated according to the following equations.

$$\begin{aligned} I_{CH} &\doteq 1.3/R \times 3 \\ t_{sm} &\doteq C/I_{CH} \times 1.6 \\ &\doteq 0.41 \times R \times C \end{aligned}$$

Continued on next page

Continued from preceding page

Because the current limiter circuit is slanted towards the ON time for turning the sink-side output on again, the reverse current will not be so large even if a rectifying diode (without a short reverse recovery time) is used as regenerative current absorption diode connected externally.

7-3. Output off time setting

The output off time must be optimized for the type of motor that is being controlled. The output off time setting is controlled by the external resistance connected to the R pin and the external capacitance connected to the C pin. Figure 1 shows the current limiter operating waveform.

(1) Short output off time setting

Because the IC is designed internally to give a ratio of about 3:1 for the output off time and output current ignore time, the two values cannot be set independently. If the output off time is set to a very small value, the output current ignore time may be too short. In such a case, the external regenerative current absorption diode acts to limit current flow by its reverse current (see section 7-2). If the output off time is small, the diode reverse current will increase, which can lead to ASO problems.

(2) Long output off time setting

If the output off time is set to a very high value, the average current will be reduced, resulting in lower motor startup torque. Depending on the motor type, the circuit may not change from the current limiter operating state to the normal rotation state.

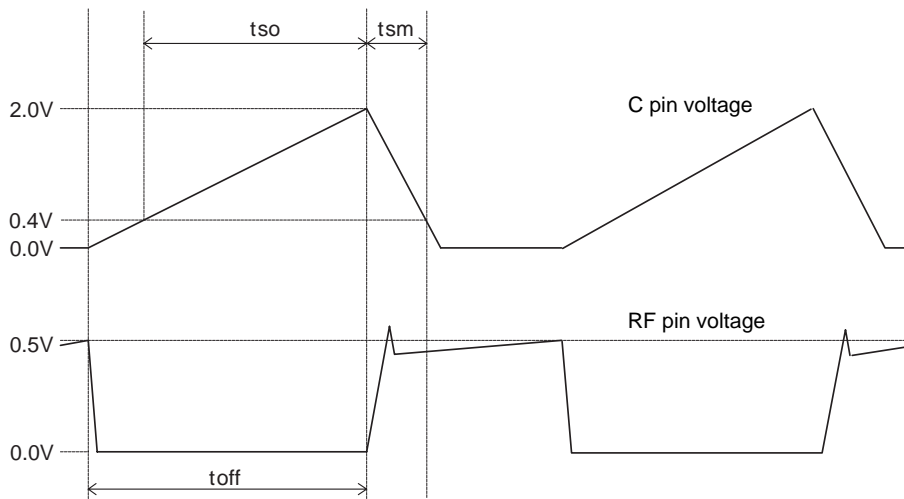

Figure. 1 Current limiter operating waveform

Continued on next page

Continued from preceding page

8. Internal power dissipation calculation

$$P_d = (V_{CC} \times I_{CC}) + (V_M \times I_M) - (\text{motor coil power dissipation})$$

9. IC temperature rise measurement

Because the chip temperature of the IC cannot be measured directly, measurement should be carried out according to one of the following procedures.

9-1. Thermocouple measurement method

A thermocouple element is mounted to the IC heat dissipation fin. This measurement method is easy to implement, but it will be subject to measurement errors if the temperature is not stable.

9-2. Measurement using internal diode characteristics of IC

This is the recommended measurement method. It makes use of the parasitic diode incorporated in the IC between FG1 and GND. Set FG1 to High (off) and measure the voltage V_F of the parasitic diode to calculate the temperature.

(Sanyo data: for $I_F = -1$ mA, V_F temperature characteristics are about -2 mV/°C)

- Specifications of any and all SANYO products described or contained herein stipulate the performance, characteristics, and functions of the described products in the independent state, and are not guarantees of the performance, characteristics, and functions of the described products as mounted in the customer's products or equipment. To verify symptoms and states that cannot be evaluated in an independent device, the customer should always evaluate and test devices mounted in the customer's products or equipment.
- SANYO Electric Co., Ltd. strives to supply high-quality high-reliability products. However, any and all semiconductor products fail with some probability. It is possible that these probabilistic failures could give rise to accidents or events that could endanger human lives, that could give rise to smoke or fire, or that could cause damage to other property. When designing equipment, adopt safety measures so that these kinds of accidents or events cannot occur. Such measures include but are not limited to protective circuits and error prevention circuits for safe design, redundant design, and structural design.
- In the event that any or all SANYO products (including technical data, services) described or contained herein are controlled under any of applicable local export control laws and regulations, such products must not be exported without obtaining the export license from the authorities concerned in accordance with the above law.
- No part of this publication may be reproduced or transmitted in any form or by any means, electronic or mechanical, including photocopying and recording, or any information storage or retrieval system, or otherwise, without the prior written permission of SANYO Electric Co., Ltd.
- Any and all information described or contained herein are subject to change without notice due to product/technology improvement, etc. When designing equipment, refer to the "Delivery Specification" for the SANYO product that you intend to use.
- Information (including circuit diagrams and circuit parameters) herein is for example only ; it is not guaranteed for volume production. SANYO believes information herein is accurate and reliable, but no guarantees are made or implied regarding its use or any infringements of intellectual property rights or other rights of third parties.

This catalog provides information as of June, 1999. Specifications and information herein are subject to change without notice.