

LM3822 Precision Current Gauge IC with Internal Zero Ohm Sense Element and PWM Output

Check for Samples: [LM3822](#)

FEATURES

- No external sense element required
- PWM output indicates the current magnitude and direction
- PWM output is easily interfaced with microprocessors and controllers
- Precision $\Delta\Sigma$ current-sense technique
- Low temperature sensitivity
- Internal filtering rejects false trips
- Internal Power-On-Reset (POR)
- DC Offset is less than 1 mA for 1A part

APPLICATIONS

- Battery charge/discharge gauge
- Motion control diagnostics
- Power supply load monitoring and management
- Resettable smart fuse

KEY SPECIFICATIONS

- Ultra low insertion loss (typically 0.003 Ω)
- 2V to 5.5V supply range
- $\pm 2\%$ accuracy at room temperature for the 1A device (includes accuracy of the internal sense element)
- Low quiescent current in shutdown mode (typically 1.8 μA)
- 50 msec sampling interval
- In MSOP-8 Package

DESCRIPTION

The LM3822 Current Gauge provides easy to use precision current measurement with virtually zero insertion loss (typically 0.003 Ω). The LM3822 is used for high-side sensing.

A Delta Sigma analog to digital converter is incorporated to precisely measure the current and to provide a current averaging function. Current is averaged over 50 msec time periods in order to provide immunity to current spikes. The ICs have a pulse-width modulated (PWM) output which indicates the current magnitude and direction. The shutdown pin can be used to inhibit false triggering during start-up, or to enter a low quiescent current mode.

The LM3822 is factory-set in two different current options. The sense range is -1.0A to $+1.0\text{A}$ or -2.0A to $+2.0\text{A}$. The sampling interval for this part is 50ms. If faster sampling is desired, please refer to the data sheet for the part number LM3824.

Connection Diagram

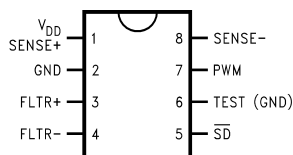

**Figure 1. Top View
LM3822 for High-Side Sensing**



Please be aware that an important notice concerning availability, standard warranty, and use in critical applications of Texas Instruments semiconductor products and disclaimers thereto appears at the end of this data sheet.

All trademarks are the property of their respective owners.

Pin Descriptions (High-Side, LM3822)

Pin	Name	Function
1	SENSE+, V_{DD}	High side of internal current sense, also supply voltage.
2	GND	Supply Ground.
3	FLTR+	Filter input — provides anti-aliasing for delta sigma modulator.
4	FLTR-	Filter input.
5	\overline{SD}	Shutdown input. Connected to V_{DD} through a pull-up resistor for normal operation. When low, the LM3822 is put into a low current mode.
6	TEST	Connect to GND for normal operation.
7	PWM	Digital output indicates the current magnitude and direction.
8	SENSE-	Low side of internal current sense.



These devices have limited built-in ESD protection. The leads should be shorted together or the device placed in conductive foam during storage or handling to prevent electrostatic damage to the MOS gates.

Absolute Maximum Ratings ⁽¹⁾

Absolute Maximum Supply Voltage	5.5V
Power Dissipation	⁽²⁾
ESD Susceptibility ⁽³⁾	1.5 kV
Sense Current (peak, for 200 msec) ⁽⁴⁾	10A
Sink Current for PWM pin	1mA
Maximum Junction Temperature	150°C
Storage Temperature	-65°C to +150°C
Lead Temperature (Soldering, 10 sec)	260°C

- (1) Absolute Maximum Ratings indicate limits beyond which damage to the device may occur. Operating Ratings indicate conditions for which the device is intended to be functional, but do not guarantee specific performance limits. For guaranteed specifications and test conditions, see Electrical Characteristics. The guaranteed specifications apply only for the test conditions listed. Some performance characteristics may degrade when the device is not operated under the listed test conditions.
- (2) At elevated temperatures, devices must be derated based on package thermal resistance. The device in the surface-mount package must be derated at $\theta_{JA} = 220^{\circ}\text{C}/\text{W}$ (typically), junction-to-ambient.
- (3) The human body model is a 100 pF capacitor discharged through a 1.5 k Ω resistor into each pin.
- (4) The absolute maximum peak and continuous currents specified are not tested. These specifications are dependent on the θ_{JA} , which is 220°C/W for the MSOP-8 package.

Operating Ratings ⁽¹⁾

Input Voltage	2.0V to 5.25V
Sense Current (continuous) ⁽²⁾	5A
Junction Temperature Range	-40°C to +85°C

- (1) Absolute Maximum Ratings indicate limits beyond which damage to the device may occur. Operating Ratings indicate conditions for which the device is intended to be functional, but do not guarantee specific performance limits. For guaranteed specifications and test conditions, see Electrical Characteristics. The guaranteed specifications apply only for the test conditions listed. Some performance characteristics may degrade when the device is not operated under the listed test conditions.
- (2) The absolute maximum peak and continuous currents specified are not tested. These specifications are dependent on the θ_{JA} , which is 220°C/W for the MSOP-8 package.

Electrical Characteristics LM3822-1.0

Typical numbers are at 25°C and represent the most likely parametric norm. Specifications in standard type face are for $T_J = 25^\circ\text{C}$ and those with **boldface type** apply over **full operating temperature ranges**.

SENSE+ $V_{DD} = 3.6\text{V}$ for the following specifications. Supply bypass capacitor is 1 μF and filter capacitor is 0.1 μF .

Symbol	Parameter	Conditions	Typ (1)	Limit (2)	Units
I_{ACC}	Average Current Accuracy ⁽³⁾	1.0A current	1.0		A
				0.98 / 0.96	A (min)
				1.02 / 1.04	A (max)
e_n	Effective Output Noise (rms)		2		mA

- (1) Typical numbers are at 25°C and represent the most likely parametric norm. Specifications in standard type face are for $T_J = 25^\circ\text{C}$ and those with **boldface type** apply over **full operating temperature ranges**.
- (2) Limits are 100% production tested at 25°C. Limits over the operating temperature range are guaranteed through correlation using Statistical Quality Control (SQC) methods. The limits are used to calculate National's Average Outgoing Quality Level (AOQL).
- (3) There is a variation in accuracy over time due to thermal effects. Please refer to the "PWM Output and Current Accuracy" section for more information.

Electrical Characteristics LM3822-2.0

SENSE+ $V_{DD} = 3.6\text{V}$ for the following specifications. Supply bypass capacitor is 1 μF and filter capacitor is 0.1 μF .

Symbol	Parameter	Conditions	Typ (1)	Limit (2)	Units
I_{ACC}	Average Current Accuracy ⁽³⁾	2.0A current ⁽⁴⁾	2.0		A
				1.94 / 1.90	A (min)
				2.06 / 2.10	A (max)
e_n	Effective Output Noise (rms)		6		mA

- (1) Typical numbers are at 25°C and represent the most likely parametric norm. Specifications in standard type face are for $T_J = 25^\circ\text{C}$ and those with **boldface type** apply over **full operating temperature ranges**.
- (2) Limits are 100% production tested at 25°C. Limits over the operating temperature range are guaranteed through correlation using Statistical Quality Control (SQC) methods. The limits are used to calculate National's Average Outgoing Quality Level (AOQL).
- (3) There is a variation in accuracy over time due to thermal effects. Please refer to the "PWM Output and Current Accuracy" section for more information.
- (4) This parameter is production tested at 1A and guaranteed by design at 2A.

Common Device Parameters

Unless otherwise specified, $V_{DD} = 3.6V$ for the following specifications. Supply bypass capacitor is $1\ \mu F$ and filter capacitor is $0.1\ \mu F$.

Symbol	Parameter	Conditions	Typ (1)	Limit (2)	Units
I_{Q1}	Quiescent Current	Normal Mode, $\overline{SD} = \text{high}$	95		μA
				150	μA (max)
I_{Q2}	Quiescent Current	Shutdown Mode, $\overline{SD} = \text{low}$	1.8		μA
				10	μA (max)
D_{RES}	PWM Resolution		0.1		%
t_S	Sampling Time		50		ms
				40	ms (min)
				80	ms (max)
f_P	Frequency of PWM Waveform		20		Hz
				12.5	Hz (min)
				25	Hz (max)
V_{TH}	Threshold High Level for \overline{SD}		1.3		V
				1.8	V (min)
V_{TL}	Threshold Low Level for \overline{SD}		1.2		V
				0.7	V (max)
V_{OH}	Logic High Level for PWM	Load current = 1 mA, $2V \leq V_{DD} \leq 5.25V$	$V_{DD} - 0.05$	$V_{DD} - 0.2$	V V (min)
V_{OL}	Logic Low Level for PWM	Sink current = 1 mA, $2V \leq V_{DD} \leq 5.25V$	0.04		V
				0.2	V (max)
P_I	Insertion Loss	$I_{SENSE} = 1A$ (3)	0.003		Ω

- (1) Typical numbers are at 25°C and represent the most likely parametric norm. Specifications in standard type face are for $T_J = 25^\circ C$ and those with **boldface type** apply over **full operating temperature ranges**.
- (2) Limits are 100% production tested at 25°C. Limits over the operating temperature range are guaranteed through correlation using Statistical Quality Control (SQC) methods. The limits are used to calculate National's Average Outgoing Quality Level (AOQL).
- (3) The tolerance of the internal lead frame resistor is corrected internally. The temperature coefficient of this resistor is 2600 ppm/°C.

Typical Performance Characteristics

Supply bypass capacitor is 0.1 μ F and filter capacitor is 0.1 μ F.

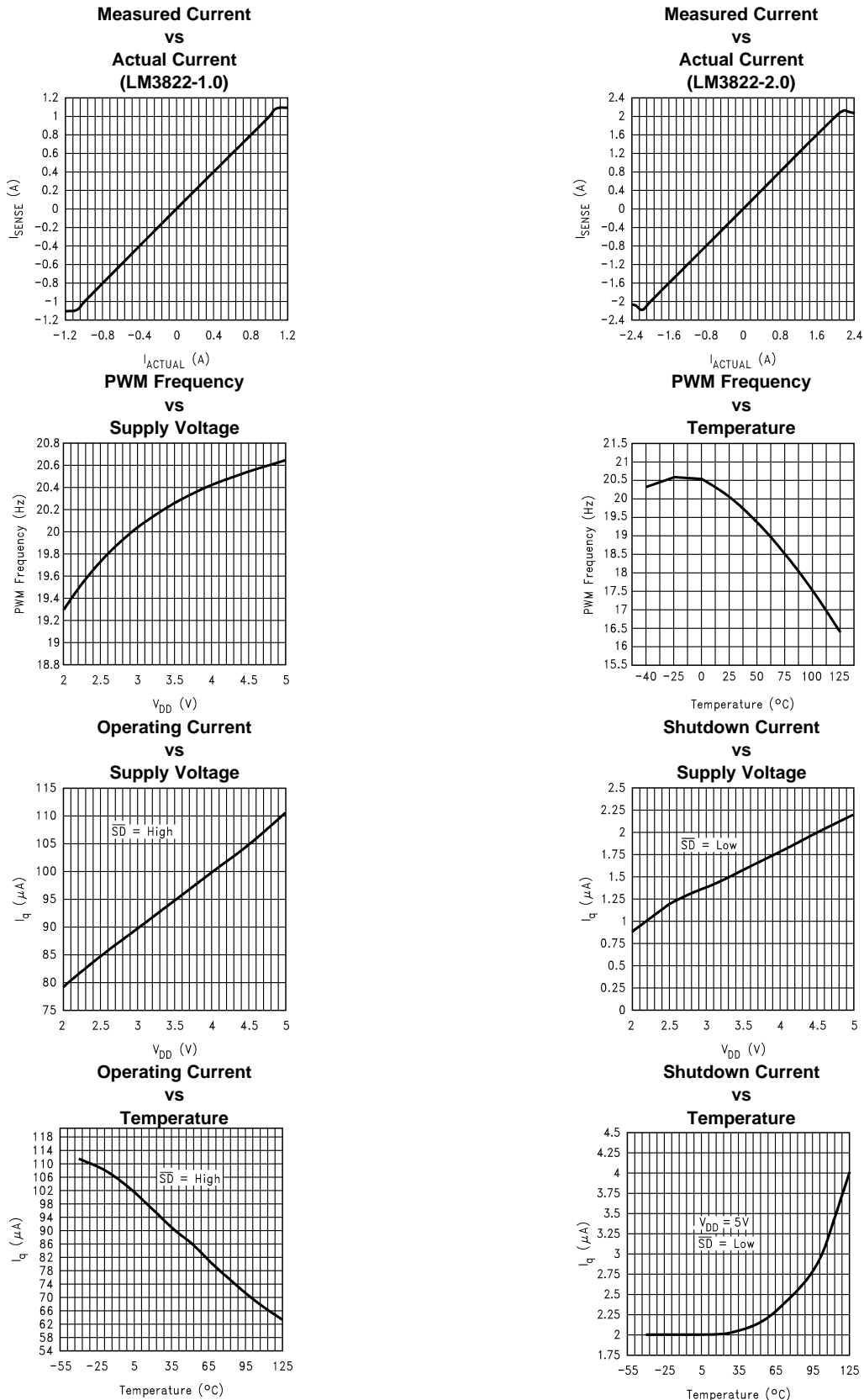

Typical Performance Characteristics (continued)

Supply bypass capacitor is 0.1 μF and filter capacitor is 0.1 μF .

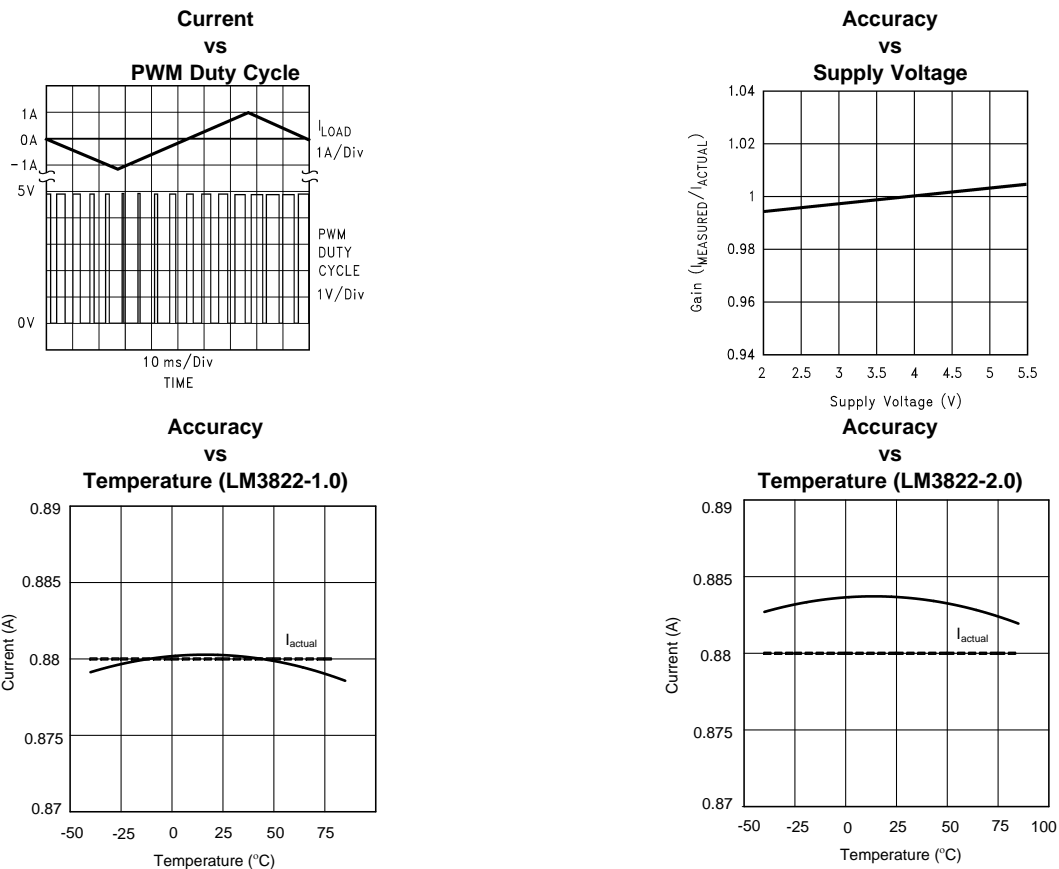

(1) These curves represent a statistical average such that the noise is insignificant.

Typical Application Circuits

In the application circuits, the 0.1 μF ceramic capacitor between pins 1 and 2 is used for bypassing, and the 0.1 μF ceramic capacitor between pins 3 and 4 is used for filtering. Shutdown ($\overline{\text{SD}}$) is tied to V_{DD} through a 10 k Ω resistor.

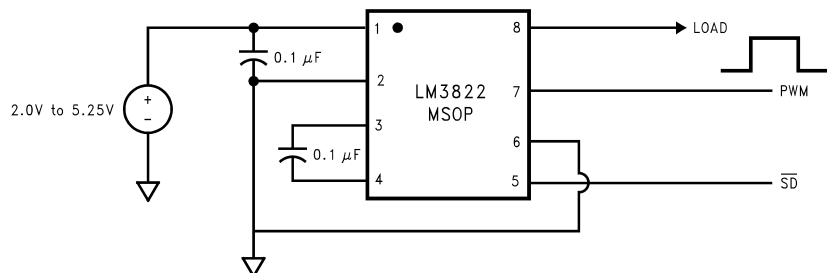
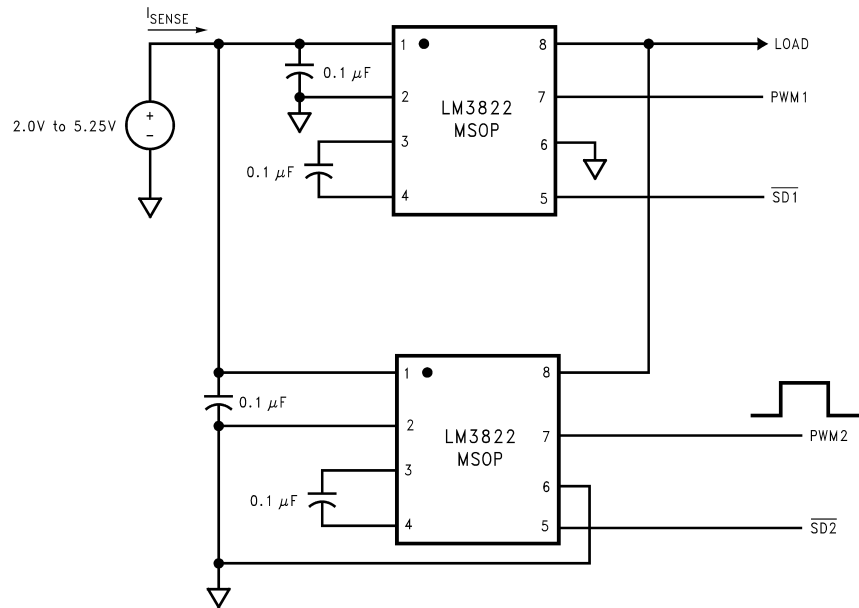

Figure 2. High Side Sense

In the application circuits, the 0.1 μF ceramic capacitor between pins 1 and 2 is used for bypassing, and the 0.1 μF ceramic capacitor between pins 3 and 4 is used for filtering. Shutdown ($\overline{\text{SD}}$) is tied to V_{DD} through a 10 k Ω resistor.



NOTE: $I_{\text{TOTAL}} = 2.2(D_1 - 0.5)I_{\text{MAX}} + 2.2(D_2 - 0.5)I_{\text{MAX}}$
 where D_1 is the duty cycle of PWM1 and D_2 is the duty cycle of PWM2.
 Please refer to the Product Operation section for more information.

Figure 3. Paralleling LM3822 for Higher Load Current

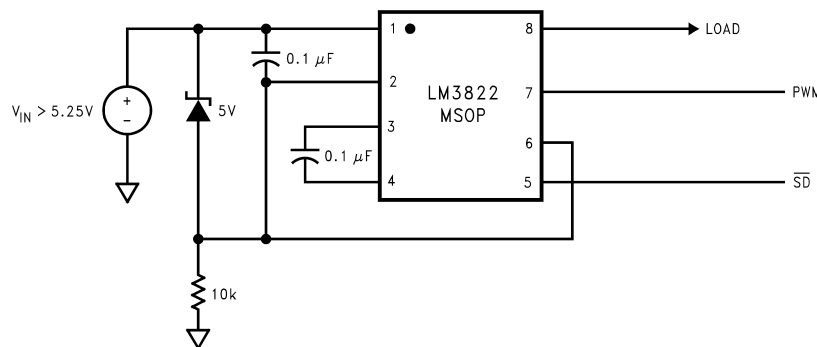

Figure 4. High Voltage Operation — V_{IN} Greater Than 5.5V (High Side Sense)
 (PWM output is referred to Pin 6)

Product Operation

The current is sampled by the delta-sigma modulator, as illustrated in Figure 5. The pulse density output of the delta-sigma modulator is digitally filtered. The digital output is then compared to the output of a digital ramp generator. This produces a PWM output. The duty cycle of the PWM output is proportional to the amount of current flowing. A duty cycle of 50% indicates zero current flow. If the current is flowing in positive direction, the duty cycle will be greater than 50%. Conversely, the duty cycle will be less than 50% for currents flowing in the negative direction. A duty cycle of 95.5% (4.5%) indicates the current is at I_{MAX} ($-I_{\text{MAX}}$). The IC can sense currents from $-I_{\text{MAX}}$ to $+I_{\text{MAX}}$. Options for I_{MAX} are 1.0A or 2.0A. The sense current is given by:

$$I_{\text{SENSE}} = 2.2 (D - 0.5) I_{\text{MAX}} \quad (1)$$

where D is the duty cycle of the PWM waveform, and I_{MAX} is the full scale current (1.00A or 2.00A). Similarly, the duty cycle is given by:

$$D = [I_{\text{SENSE}} / (2.2 I_{\text{MAX}})] + 0.5 \quad (2)$$

In the application circuits, the 0.1 μF ceramic capacitor between pins 1 and 2 is used for bypassing, and the 0.1 μF ceramic capacitor between pins 3 and 4 is used for filtering. Shutdown ($\overline{\text{SD}}$) is tied to V_{DD} through a 10 k Ω resistor.

For quick reference, see the Conversion Table in [Table 1](#).

In this IC, the current is averaged over 50 msec time slots. Hence, momentary current surges of less than 50 msec are tolerated.

This is a sampled data system which requires an anti-aliasing filter, provided by the filter capacitor.

The delta-sigma modulator converts the sensed current to the digital domain. This allows digital filtering, and provides immunity to current and noise spikes. This type of filtering would be difficult or impossible to accomplish on an IC with analog components.

The user also needs to specify the full scale value. See the Ordering Information table for details.

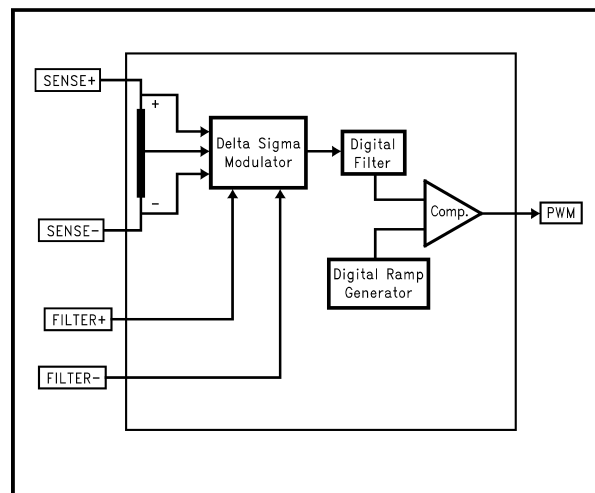

Figure 5. Functional block diagram of LM3822

PWM Output and Current Accuracy

OFFSET

The PWM output is quantized to 1024 levels. Therefore, the duty cycle can change only in increments of 1/1024.

There is a one-half (0.5) quantization cycle delay in the output of the PWM circuitry. That is to say that instead of a duty cycle of $N/1024$, the duty cycle actually is $(N+1/2)/1024$.

The quantization error can be corrected for if a more precise result is desired. To correct for this error, simply subtract 1/2048 from the measured duty cycle.

The extra half cycle delay will show up as a DC offset of $1/2$ bit if it is not corrected for. This is approximately 1.0 mA for 1.0 Amp parts, and 10 mA for 2.0 Amp parts.

JITTER

In addition to quantization, the duty cycle will contain some jitter. The jitter is quite small (for example, the standard deviation of jitter is only 0.1% for the LM3822-1.0). Statistically the jitter can cause an error in a current sample. Because the jitter is a random variable, the mean and standard deviation are used. The mean, or average value, of the jitter is zero. The standard deviation (0.1%) can be used to define the peak error caused from jitter.

The “crest factor” has often been used to define the maximum error caused by jitter. The crest factor defines a limit within which 99.7% of the samples fall. The crest factor is defined as $\pm 0.3\%$ error in the duty cycle.

Since the jitter is a random variable, averaging multiple outputs will reduce the effective jitter. Obeying statistical laws, the jitter is reduced by the square root of the number of readings that are averaged. For example, if four readings of the duty cycle are averaged, the resulting jitter (and crest factor) are reduced by a factor of two.

In the application circuits, the 0.1 μ F ceramic capacitor between pins 1 and 2 is used for bypassing, and the 0.1 μ F ceramic capacitor between pins 3 and 4 is used for filtering. Shutdown (\overline{SD}) is tied to V_{DD} through a 10 k Ω resistor.

JITTER AND NOISE

Jitter in the PWM output appears as noise in the current measurement. The Electrical Characteristics show noise measured in current RMS (root mean square). Arbitrarily one could specify PWM jitter, as opposed to noise. In either case the effect results in a random error in an individual current measurement.

Noise, just like jitter, can be reduced by averaging many readings. The RMS value of the noise corresponds to one standard deviation. The “crest factor” can be calculated in terms of current, and is equal to ± 3 sigma (RMS value of the noise).

Noise will also be reduced by averaging multiple readings, and follows the statistical laws of a random variable.

ACCURACY VERSUS NOISE

The graph shown in Figure 6 illustrates the typical response of ± 1 Ampere current gauges. In this graph, the horizontal axis indicates time, and the vertical axis indicates measured current (the PWM duty cycle has been converted to current). The graph was generated for an actual current of 500 mA.

The difference between successive readings manifests itself as jitter in the PWM output or noise in the current measurement (when duty cycle of the PWM output is converted to current).

The accuracy of the measurement depends on the noise in the current waveform. The accuracy can be improved by averaging several outputs. Although there is variation in successive readings, a very accurate measurement can be obtained by averaging the readings. For example, on averaging the readings shown in this example, the average current measurement is 502.3 mA (Figure 6). This value is very close to the actual value of 500 mA. Moreover, the accuracy depends on the number of readings that are averaged.

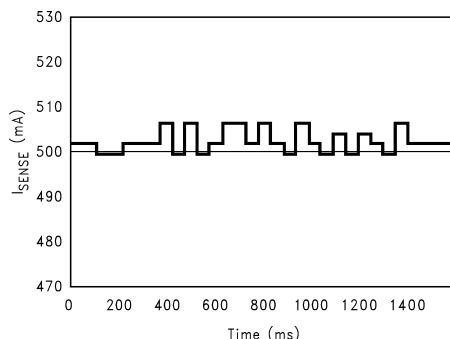

Figure 6. Typical Response of LM3822

LOW CURRENT MEASUREMENTS

The DC offset of the LM3822-1.0 is typically under 1 mA. This low offset allows accurate low current measurements. Even currents in the 10 mA range can be measured with accuracies typically better than $\pm 5\%$.

Look-Up Tables

The following tables show how to convert the duty cycle of the PWM output to a current value, and vice versa. The quantization error of $\frac{1}{2}$ bit is not shown in these tables. Please see the “PWM Output and Current Accuracy” section for more details.

Table 1. Current to Duty Cycle Conversion Table

Sense Current ($I_{max} = 1.0A$)	Sense Current ($I_{max} = 2.0A$)	Duty Cycle (%)
1	2	95.5
0.95	1.90	93.2
0.90	1.80	90.9
0.85	1.70	88.6

Table 1. Current to Duty Cycle Conversion Table (continued)

Sense Current ($I_{max} = 1.0A$)	Sense Current ($I_{max} = 2.0A$)	Duty Cycle (%)
0.80	1.60	86.4
0.75	1.50	84.1
0.70	1.40	81.8
0.65	1.30	79.5
0.60	1.20	77.3
0.55	1.10	75.0
0.50	1	72.7
0.45	0.90	70.5
0.40	0.80	68.2
0.35	0.70	65.9
0.30	0.60	63.6
0.25	0.50	61.4
0.20	0.40	59.1
0.15	0.30	56.8
0.10	0.20	54.5
0.05	0.10	52.3
0.00	0.00	50
-0.05	-0.10	47.7
-0.10	-0.20	45.5
-0.15	-0.30	43.2
-0.20	-0.40	40.9
-0.25	-0.50	38.6
-0.30	-0.60	36.4
-0.35	-0.70	34.1
-0.40	-0.80	31.8
-0.45	-0.90	29.5
-0.50	-1	27.3
-0.55	-1.10	25
-0.60	-1.20	22.7
-0.65	-1.30	20.5
-0.70	-1.40	18.2
-0.75	-1.50	15.9
-0.80	-1.60	13.6
-0.85	-1.70	11.4
-0.90	-1.80	9.1
-0.95	-1.90	6.8
-1	-2	4.5

TEST CIRCUIT DIAGRAMS

Timing Diagram

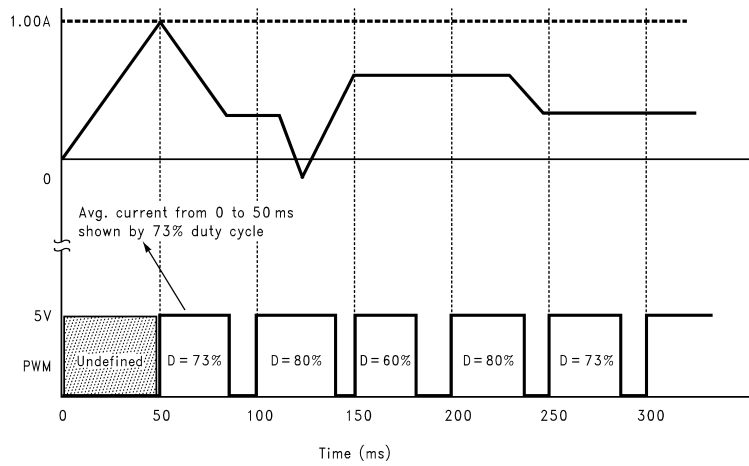

Duty cycle of the PWM waveform during any sampling interval indicates the current magnitude (average) and direction during the previous sampling interval.

Figure 7. Typical Timing Diagram for Mostly Positive Current

IMPORTANT NOTICE

Texas Instruments Incorporated and its subsidiaries (TI) reserve the right to make corrections, enhancements, improvements and other changes to its semiconductor products and services per JESD46, latest issue, and to discontinue any product or service per JESD48, latest issue. Buyers should obtain the latest relevant information before placing orders and should verify that such information is current and complete. All semiconductor products (also referred to herein as "components") are sold subject to TI's terms and conditions of sale supplied at the time of order acknowledgment.

TI warrants performance of its components to the specifications applicable at the time of sale, in accordance with the warranty in TI's terms and conditions of sale of semiconductor products. Testing and other quality control techniques are used to the extent TI deems necessary to support this warranty. Except where mandated by applicable law, testing of all parameters of each component is not necessarily performed.

TI assumes no liability for applications assistance or the design of Buyers' products. Buyers are responsible for their products and applications using TI components. To minimize the risks associated with Buyers' products and applications, Buyers should provide adequate design and operating safeguards.

TI does not warrant or represent that any license, either express or implied, is granted under any patent right, copyright, mask work right, or other intellectual property right relating to any combination, machine, or process in which TI components or services are used. Information published by TI regarding third-party products or services does not constitute a license to use such products or services or a warranty or endorsement thereof. Use of such information may require a license from a third party under the patents or other intellectual property of the third party, or a license from TI under the patents or other intellectual property of TI.

Reproduction of significant portions of TI information in TI data books or data sheets is permissible only if reproduction is without alteration and is accompanied by all associated warranties, conditions, limitations, and notices. TI is not responsible or liable for such altered documentation. Information of third parties may be subject to additional restrictions.

Resale of TI components or services with statements different from or beyond the parameters stated by TI for that component or service voids all express and any implied warranties for the associated TI component or service and is an unfair and deceptive business practice. TI is not responsible or liable for any such statements.

Buyer acknowledges and agrees that it is solely responsible for compliance with all legal, regulatory and safety-related requirements concerning its products, and any use of TI components in its applications, notwithstanding any applications-related information or support that may be provided by TI. Buyer represents and agrees that it has all the necessary expertise to create and implement safeguards which anticipate dangerous consequences of failures, monitor failures and their consequences, lessen the likelihood of failures that might cause harm and take appropriate remedial actions. Buyer will fully indemnify TI and its representatives against any damages arising out of the use of any TI components in safety-critical applications.

In some cases, TI components may be promoted specifically to facilitate safety-related applications. With such components, TI's goal is to help enable customers to design and create their own end-product solutions that meet applicable functional safety standards and requirements. Nonetheless, such components are subject to these terms.

No TI components are authorized for use in FDA Class III (or similar life-critical medical equipment) unless authorized officers of the parties have executed a special agreement specifically governing such use.

Only those TI components which TI has specifically designated as military grade or "enhanced plastic" are designed and intended for use in military/aerospace applications or environments. Buyer acknowledges and agrees that any military or aerospace use of TI components which have **not** been so designated is solely at the Buyer's risk, and that Buyer is solely responsible for compliance with all legal and regulatory requirements in connection with such use.

TI has specifically designated certain components as meeting ISO/TS16949 requirements, mainly for automotive use. In any case of use of non-designated products, TI will not be responsible for any failure to meet ISO/TS16949.

Products

Audio	www.ti.com/audio
Amplifiers	amplifier.ti.com
Data Converters	dataconverter.ti.com
DLP® Products	www.dlp.com
DSP	dsp.ti.com
Clocks and Timers	www.ti.com/clocks
Interface	interface.ti.com
Logic	logic.ti.com
Power Mgmt	power.ti.com
Microcontrollers	microcontroller.ti.com
RFID	www.ti-rfid.com
OMAP Applications Processors	www.ti.com/omap
Wireless Connectivity	www.ti.com/wirelessconnectivity

Applications

Automotive and Transportation	www.ti.com/automotive
Communications and Telecom	www.ti.com/communications
Computers and Peripherals	www.ti.com/computers
Consumer Electronics	www.ti.com/consumer-apps
Energy and Lighting	www.ti.com/energy
Industrial	www.ti.com/industrial
Medical	www.ti.com/medical
Security	www.ti.com/security
Space, Avionics and Defense	www.ti.com/space-avionics-defense
Video and Imaging	www.ti.com/video

TI E2E Community

e2e.ti.com