

LM75 Digital Temperature Sensor and Thermal Watchdog with Two-Wire Interface

General Description

The LM75 is a temperature sensor, Delta-Sigma analog-to-digital converter, and digital over-temperature detector with I²C® interface. The host can query the LM75 at any time to read temperature. The open-drain Overtemperature Shutdown (O.S.) output becomes active when the temperature exceeds a programmable limit. This pin can operate in either "Comparator" or "Interrupt" mode.

The host can program both the temperature alarm threshold (T_{OS}) and the temperature at which the alarm condition goes away (T_{HYST}). In addition, the host can read back the contents of the LM75's T_{OS} and T_{HYST} registers. Three pins (A0, A1, A2) are available for address selection. The sensor powers up in Comparator mode with default thresholds of 80°C T_{OS} and 75°C T_{HYST}.

The LM75's 3.0V to 5.5V supply voltage range, low supply current, and I²C® interface make it ideal for a wide range of applications. These include thermal management and protection applications in personal computers, electronic test equipment, and office electronics.

Features

- Tiny SO-8 package saves space (SOT-8 under development)
- I²C® Bus interface
- Separate open-drain output pin operates as interrupt or comparator/thermostat output
- Register readback capability
- Power up defaults permit stand-alone operation as thermostat
- Shutdown mode to minimize power consumption
- Up to 8 LM75s can be connected to a single bus

Key Specifications

- | | |
|----------------------------|--|
| ■ Supply Voltage | 3.0V to 5.5V |
| ■ Supply Current operating | 250 µA (typ)
1 mA (max) |
| shutdown | 1 µA (typ) |
| ■ Temperature Accuracy | -25°C to 100°C ±2°C(max)
-55°C to 125°C ±3°C(max) |

Applications

- System Thermal Management
- Personal Computers
- Office Electronics
- Electronic Test Equipment

Simplified Block Diagram

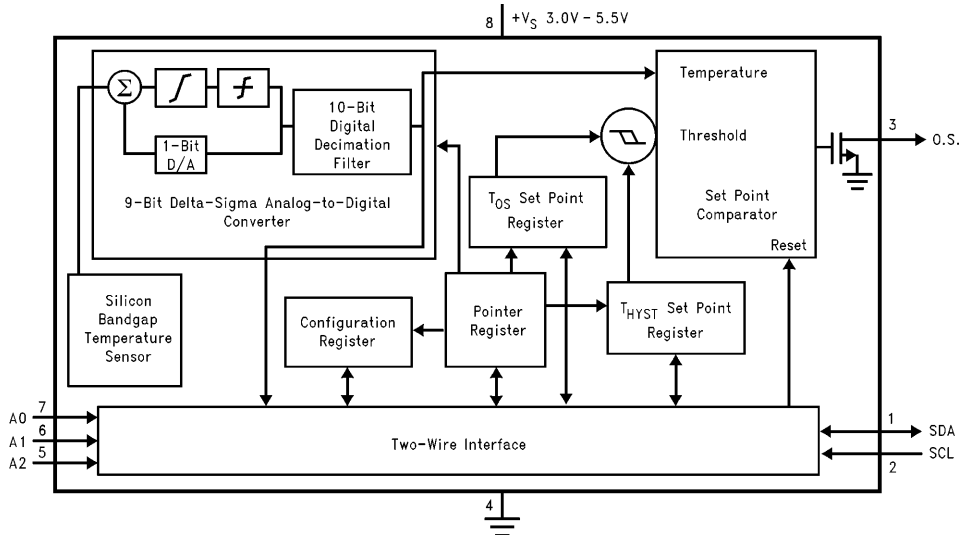

TL/H/12658-1

 I²C® is a registered trademark of Philips Corporation.

Connection Diagrams

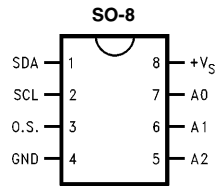

Order Number **LM75CIM-3, LM75CIMX-3, LM75CIM-5 or LM75CIMX-5**
See NS Package Number **M08A**

TL/H/12658-2

Ordering Information

Order Number	Supply Voltage	Supplied As
LM75CIM-3	3.3V	
LM75CIMX-3	3.3V	2500 Units on Tape and Reel
LM75CIM-5	5V	
LM75CIMX-5	5V	2500 Units on Tape and Reel

Pin Description

Label	Pin #	Function	Typical Connection
SDA	1	I ² C [®] Serial Bi-Directional Data Line	From Controller
SCL	2	I ² C [®] Clock Input	From Controller
O.S.	3	Overtemperature Shutdown Open Collector Output	Pull Up Resistor, Controller Interrupt Line
GND	4	Power Supply Ground	Ground
+V _S	8	Positive Supply Voltage Input	DC Voltage from 3V to 5.5V
A0-A2	7,6,5	User-Set I ² C [®] Address Inputs	Ground (Low, "0") or +V _S (High, "1")

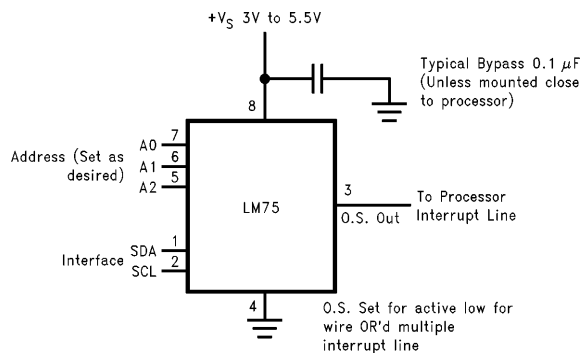

TL/H/12658-3

FIGURE 1. Typical Application

Absolute Maximum Ratings (Note 1)

Supply Voltage	-0.3V to 6.5V
Voltage at any Pin	-0.3V to $+V_S + 0.3V$
Input Current at any Pin (Note 2)	5 mA
Package Input Current (Note 2)	20 mA
O.S. Output Sink Current	10 mA
O.S. Output Voltage	6.5V
Storage Temperature	-65°C to +150°C
Soldering Information, Lead Temperature SO Package (Note 3)	
Vapor Phase (60 seconds)	215°C
Infrared (15 seconds)	220°C

ESD Susceptibility (Note 4)

Human Body Model	950V
Machine Model	950V

Operating Ratings

Specified Temperature Range (Note 5)	T_{MIN} to T_{MAX} -55°C to +125°C
Supply Voltage Range ($+V_S$)	+3.0V to +5.5V

Temperature-to-Digital Converter Characteristics

Unless otherwise noted, these specifications apply for $+V_S = +5$ Vdc for LM75CIM-5 and $+V_S = +3.3$ Vdc for LM75CIM-3 (Note 6). **Boldface limits apply for $T_A = T_J = T_{MIN}$ to T_{MAX}** ; all other limits $T_A = T_J = +25^\circ\text{C}$, unless otherwise noted.

Parameter	Conditions	Typical (Note 12)	Limits (Note 7)	Units (Limit)
Accuracy	$T_A = -25^\circ\text{C}$ to $+100^\circ\text{C}$ $T_A = -55^\circ\text{C}$ to $+125^\circ\text{C}$		± 2.0 ± 3.0	$^\circ\text{C}$ (max)
Resolution		9		Bits
Temperature Conversion Time	(Note 8)	100		ms
Quiescent Current	I ² C Inactive I ² C Active Shutdown Mode	0.25 1	1.0	mA mA (max) μA
O.S. Output Saturation Voltage	I _{OUT} = 4.0 mA (Note 9)		0.8	V (max)
O.S. Delay	(Note 10)		1 6	Conversions (min) Conversions (max)
T _{OS} Default Temperature	(Note 11)	80		$^\circ\text{C}$
T _{HYST} Default Temperature	(Note 11)	75		$^\circ\text{C}$

Logic Electrical Characteristics

DIGITAL DC CHARACTERISTICS

Unless otherwise noted, these specifications apply for $+V_S = +5$ Vdc. **Boldface limits apply for $T_A = T_J = T_{MIN}$ to T_{MAX}** ; all other limits $T_A = T_J = +25^\circ\text{C}$, unless otherwise noted.

Symbol	Parameter	Conditions	Typical (Note 12)	Limits (Note 7)	Units (Limit)
V _{IN(1)}	Logical "1" Input Voltage			$+V_S \times 0.7$ $+V_S + 0.5$	V (min) V (max)
V _{IN(0)}	Logical "0" Input Voltage			-0.3 $+V_S \times 0.3$	V (min) V (max)
I _{IN(1)}	Logical "1" Input Current	V _{IN} = 5V	0.005	1.0	μA (max)
I _{IN(0)}	Logical "0" Input Current	V _{IN} = 0V	-0.005	-1.0	μA (max)
C _{IN}	All Digital Inputs		20		pF
I _{OH}	High Level Output Current	V _{OH} = 5V		100	μA (max)
V _{OL}	Low Level Output Voltage	I _{OL} = 3 mA		0.4	V (max)
t _{OF}	Output Fall Time	C _L = 400 pF I _O = 3 mA		250	ns (max)

Logic Electrical Characteristics (Continued)

I²C DIGITAL SWITCHING CHARACTERISTICS

Unless otherwise noted, these specifications apply for $+V_S = +5$ Vdc, C_L (load capacitance) on output lines = 80 pF unless otherwise specified. **Boldface limits apply for $T_A = T_J = T_{MIN}$ to T_{MAX}** ; all other limits $T_A = T_J = +25^\circ\text{C}$, unless otherwise noted.

The switching characteristics of the LM75 fully meet or exceed the published specifications of the I²C[®] bus. The following parameters are the timing relationships between SCL and SDA signals related to the LM75. They are not the I²C[®] bus specifications.

Symbol	Parameter	Conditions	Typical (Note 12)	Limits (Note 7)	Units (Limit)
t_1	SCL (Clock) Period			2.5	$\mu\text{s}(\text{min})$
t_2	Data in Set-Up Time to SCL High			100	ns(min)
t_3	Data Out Stable after SCL Low			0	ns(min)
t_4	SDA Low Set-Up Time to SCL Low (Start Condition)			100	ns(min)
t_5	SDA High Hold Time after SCL High (Stop Condition)			100	ns(min)

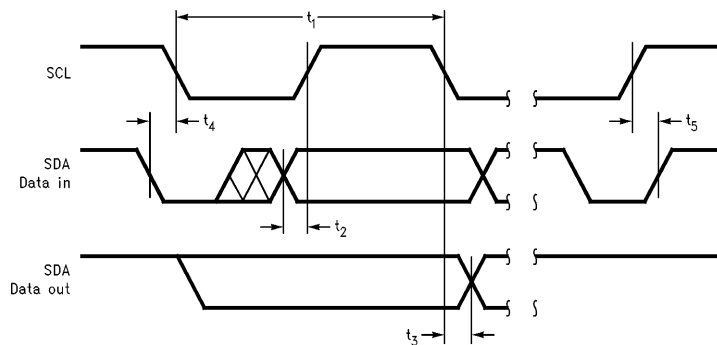

TL/H/12658-4

Note 1: Absolute Maximum Ratings indicate limits beyond which damage to the device may occur. DC and AC electrical specifications do not apply when operating the device beyond its rated operating conditions.

Note 2: When the input voltage (V_I) at any pin exceeds the power supplies ($V_I < \text{GND}$ or $V_I > +V_S$) the current at that pin should be limited to 5 mA. The 20 mA maximum package input current rating limits the number of pins that can safely exceed the power supplies with an input current of 5 mA to four.

Note 3: See AN-450 "Surface Mounting Methods and Their Effect on Product Reliability" or the section titled "Surface Mount" found in a current National Semiconductor Linear Data Book for other methods of soldering surface mount devices.

Note 4: Human body model, 100 pF discharged through a 1.5 k Ω resistor. Machine model, 200 pF discharged directly into each pin.

Note 5: Thermal resistance of the SO-8 package is 200 $^\circ\text{C}/\text{W}$, junction-to-ambient when attached to a printed circuit board with 2 oz. foil as shown in Figure 3.

Note 6: Both part numbers of the LM75 will operate properly over the $+V_S$ supply voltage range of 3V to 5.5V. The devices are tested and specified for rated accuracy at their nominal supply voltage. Accuracy will typically degrade 1 $^\circ\text{C}/\text{V}$ of variation in $+V_S$ as it varies from the nominal value.

Note 7: Limits are guaranteed to National's AOQL (Average Outgoing Quality Level).

Note 8: This specification is provided only to indicate how often temperature data is updated. The LM75 can be read at any time without regard to conversion state (and will yield last conversion result). If a conversion is in process it will be interrupted and restarted after the end of the read.

Note 9: For best accuracy, minimize output loading. Higher sink currents can affect sensor accuracy with internal heating. This can cause an error of 0.64 $^\circ\text{C}$ at full rated sink current and saturation voltage based on junction-to-ambient thermal resistance.

Note 10: O.S. Delay is user programmable up to 6 "over limit" conversions before O.S. is set to minimize false tripping in noisy environments.

Note 11: Default values set at power up.

Note 12: Typicals are at $T_A = 25^\circ\text{C}$ and represent most likely parametric norm.

Electrical Characteristics (Continued)

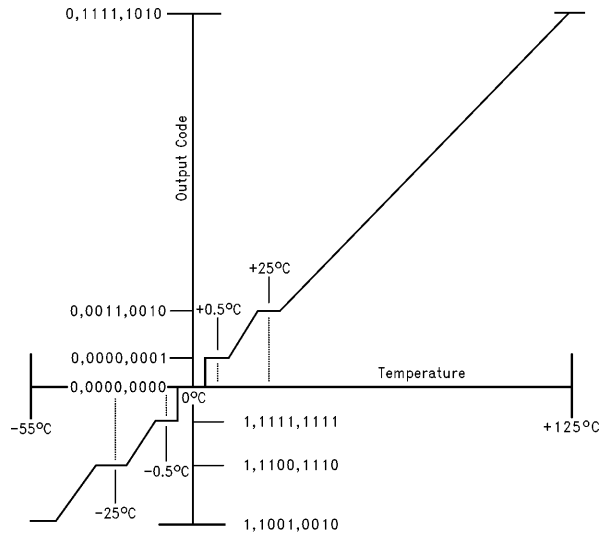

FIGURE 2. Temperature-to-Digital Transfer Function (Non-linear scale for clarity) TL/H/12658-5

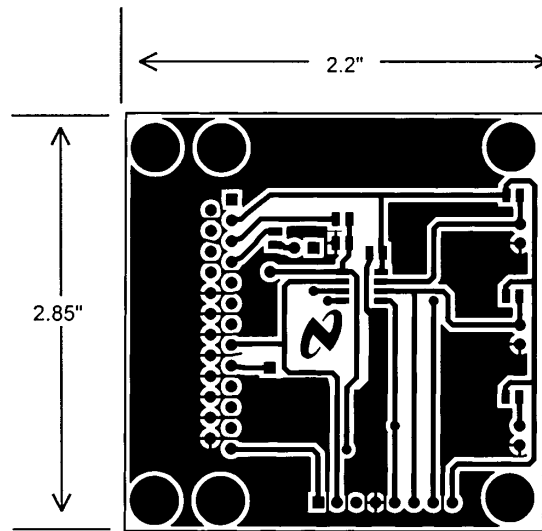

FIGURE 3. Printed Circuit Board Used for Thermal Resistance Specifications TL/H/12658-6

1.0 Functional Description

The LM75 temperature sensor incorporates a band-gap type temperature sensor and 9-bit ADC (Delta-Sigma Analog-to-Digital Converter). The temperature data output of the LM75 is available at all times via the I²C[®] bus. If a conversion is in progress, it will be stopped and restarted after the read. A digital comparator is also incorporated that compares a series of readings, the number of which is user-selectable, to user-programmable setpoint and hysteresis values. The comparator trips the O.S. output line, which is programmable for mode and polarity.

1.1 O.S. OUTPUT, T_{OS} AND T_{HYST} LIMITS

In Comparator mode the O.S. Output behaves like a thermostat. The output becomes active when temperature exceeds the T_{OS} limit, and leaves the active state when the temperature drops below the T_{HYST} limit. In this mode the O.S. output can be used to turn a cooling fan on, initiate an emergency system shutdown, or reduce system clock speed. Shutdown mode does not reset O.S. state in a comparator mode.

In Interrupt mode exceeding T_{OS} also makes O.S. active but O.S. will remain active indefinitely until reset by reading any register via the I²C[®] interface. Once O.S. has been activated by crossing T_{OS}, then reset, it can be activated again only by Temperature going below T_{HYST}. Again, it will remain active indefinitely until being reset by a read. Placing the LM75 in shutdown mode also resets the O.S. Output.

1.2 DEFAULT MODES

LM75 always powers up in a known state. LM75 power up default conditions are:

1. Comparator mode
2. T_{OS} set to 80°C
3. T_{HYST} set to 75°C
4. O.S. active low
5. Pointer set to "00"; Temperature Register

With these operating conditions LM75 can act as a stand-alone thermostat with the above temperature settings. Connection to an I²C[®] bus is not required.

1.3 I²C[®] BUS INTERFACE

The LM75 operates as a slave on the I²C bus, so the SCL line is an input (no clock is generated by the LM75) and the SDA line is a bi-directional serial data path. According to I²C[®] bus specifications, the LM75 has a 7-bit slave address. The four most significant bits of the slave address are hard wired inside the LM75 and are "1001". The three least significant bits of the address are assigned to pins A2–A0, and are set by connecting these pins to ground for a low, (0); or to +V_S for a high, (1).

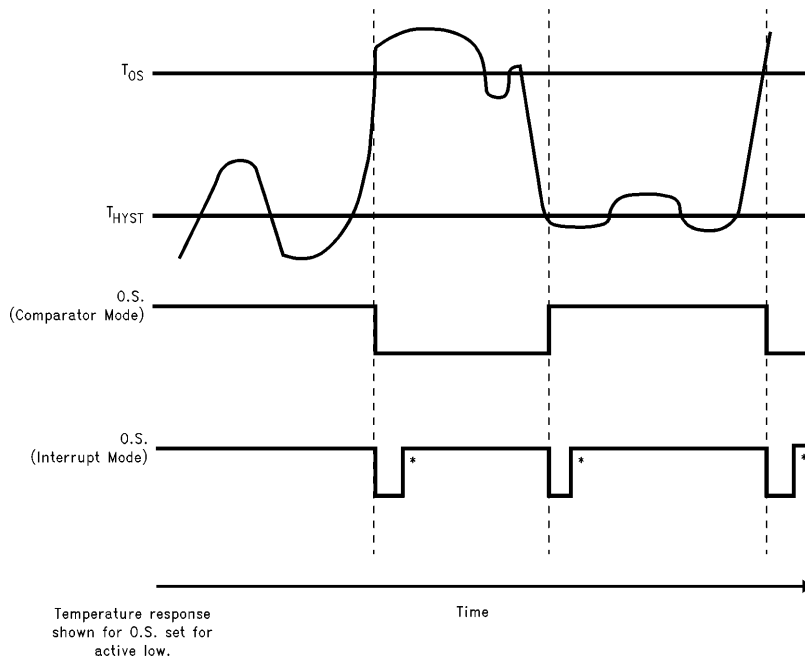

TL/H/12658-7

*Note: These interrupt mode resets of O.S. occur only when LM75 is read or placed in shutdown. Otherwise, O.S. would remain active indefinitely for any event.

FIGURE 4. O.S. Output Temperature Response Diagram

1.0 Functional Description (Continued)

Therefore, the complete slave address is:

1	0	0	1	A2	A1	A0
MSB				LSB		

1.4 TEMPERATURE DATA FORMAT

Temperature data can be read from the Temperature, T_{OS} Set Point, and T_{HYST} Set Point registers; and written to the T_{OS} Set Point, and T_{HYST} Set Point registers. Temperature data is represented by a 9-bit, two's complement word with an LSB (Least Significant Bit) equal to 0.5°C:

Temperature	Digital Output	
	Binary	Hex
+125°C	0 1111 1010	0FAh
+25°C	0 0011 0010	032h
+0.5°C	0 0000 0001	001h
0°C	0 0000 0000	000h
-0.5°C	1 1111 1111	1FFh
-25°C	1 1100 1110	1CEh
-55°C	1 1001 0010	192h

1.5 SHUTDOWN MODE

Shutdown mode is enabled by setting the shutdown bit in the Configuration register via the I²C® bus. Shutdown mode reduces power supply current to 1 μ A typical. In Interrupt mode O.S. is reset if previously set and is undefined in Comparator mode during shutdown. The I²C® interface remains active. Activity on the clock and data lines of the I²C® bus may slightly increase shutdown mode quiescent current. T_{OS} , T_{HYST} , and Configuration registers can be read from and written to in shutdown mode.

1.6 FAULT QUEUE

A fault queue of up to 6 faults is provided to prevent false tripping of O.S. when the LM75 is used in noisy environments. The number of faults set in the queue must occur consecutively to set the O.S. output.

1.7 COMPARATOR/INTERRUPT MODE

As indicated in the O.S. Output Temperature Response Diagram, *Figure 4*, the events that trigger O.S. are identical for either Comparator or Interrupt mode. The most important difference is that in Interrupt mode the O.S. will remain set indefinitely once it has been set. To reset O.S. while in Interrupt mode, perform a read from any register in the LM75.

1.8 O.S. OUTPUT

The O.S. output is an open-drain output and does not have an internal pull-up. A "high" level will not be observed on this pin until pull-up current is provided from some external source, typically a pull-up resistor. Choice of resistor value depends on many system factors but, in general, the pull-up resistor should be as large as possible. This will minimize any errors due to internal heating of the LM75. The maximum resistance of the pull up, based on LM75 specification for High Level Output Current, to provide a 2V high level, is 30 k Ω .

1.9 O.S. POLARITY

The O.S. output can be programmed via the configuration register to be either active low (default mode), or active high. In active low mode the O.S. output goes low when triggered exactly as shown on the O.S. Output Temperature Response Diagram, *Figure 4*. Active high simply inverts the polarity of the O.S. output.

1.0 Functional Description (Continued)

1.10 INTERNAL REGISTER STRUCTURE

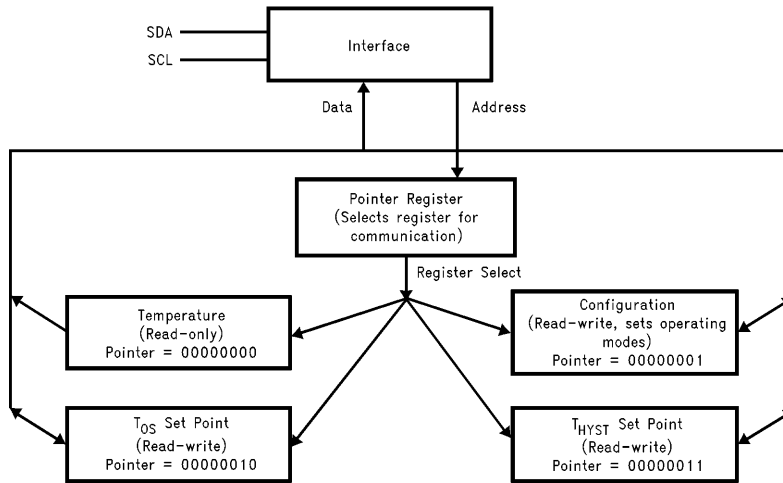

TL/H/12658-8

There are four data registers in the LM75, selected by the Pointer register. At power-up the Pointer is set to "00"; the location for the Temperature Register. The Pointer register latches whatever the last location it was set to. In Interrupt Mode, a read from the LM75, or placing the device in shut-down mode, resets the O.S. output. All registers are read and write, except the Temperature register which is read only.

A write to the LM75 will always include the address byte and the Pointer byte. A write to the Configuration register requires one data byte, and the TOS and THYST registers require two data bytes.

Reading the LM75 can take place either of two ways: If the location latched in the Pointer is correct (most of the time it is expected that the Pointer will point to the Temperature register because it will be the data most frequently read from the LM75), then the read can simply consist of an address byte, followed by retrieving the corresponding number of data bytes. If the Pointer needs to be set, then an ad-

dress byte, pointer byte, repeat start, and another address byte will accomplish a read.

The first data byte is the most significant byte with most significant bit first, permitting only as much data as necessary to be read to determine temperature condition. For instance, if the first four bits of the temperature data indicates an overtemperature condition, the host processor could immediately take action to remedy the excessive temperatures. At the end of a read, the LM75 can accept either Acknowledge or No Acknowledge from the Master (No Acknowledge is typically used as a signal for the slave that the Master has read its last byte).

An inadvertent 8-bit read from a 16-bit register, with the D7 bit low, can cause the LM75 to stop in a state where the SDA line is held low as shown in Figure 5. This can prevent any further bus communication until at least 9 additional clock cycles have occurred. Alternatively, the master can issue clock cycles until SDA goes high, at which time issuing a "Stop" condition will reset the LM75.

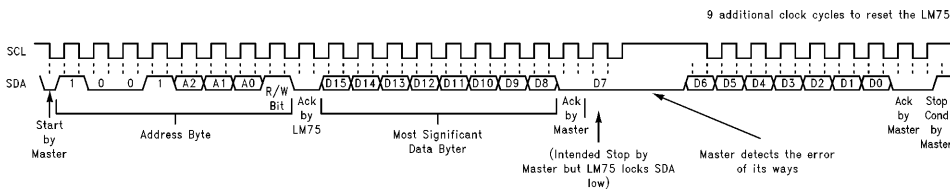

FIGURE 5. Inadvertent 8-Bit Read from 16-Bit Register where D7 is Zero ("0")

TL/H/12658-9

1.0 Functional Description (Continued)

1.11 POINTER REGISTER (Selects which registers will be read from or written to):

P7	P6	P5	P4	P3	P2	P1	P0
0	0	0	0	0	0	Register Select	

P0-P1: Register Select:

P1	P0	Register
0	0	Temperature (Read only)(Power-up default)
0	1	Configuration (Read/Write)
1	0	T _{HYST} (Read/Write)
1	1	T _{OS} (Read/Write)

P2-P7: Must be kept zero.

1.12 TEMPERATURE REGISTER (Read Only):

D15	D14	D13	D12	D11	D10	D9	D8	D7	D6	D5	D4	D3	D2	D1	D0
MSB	Bit 7	Bit 6	Bit 5	Bit 4	Bit 3	Bit 2	Bit 1	LSB	X	X	X	X	X	X	X

D0-D6: Undefined

D7-D15: Temperature Data. One LSB = 0.5°C. Two's complement format.

1.13 CONFIGURATION REGISTER (Read/Write):

D7	D6	D5	D4	D3	D2	D1	D0
0	0	0	Fault Queue		O.S. Polarity	Cmp/Int	Shutdown

Power up default is with all bits "0" (zero).

D0: Shutdown: When set to 1 the LM75 goes to low power shutdown mode.

D1: Comparator/Interrupt mode: 0 is Comparator mode, 1 is Interrupt mode.

D2: O.S. Polarity: 0 is active low, 1 is active high. O.S. is an open-drain output under all conditions.

D3-D4: Fault Queue: Number of faults necessary to detect before setting O.S. output to avoid false tripping due to noise:

D4	D3	Number of Faults
0	0	1 (Power-up default)
0	1	2
1	0	4
1	1	6

D5-D7: These bits are used for production testing and must be kept zero for normal operation.

1.0 Functional Description (Continued)

1.14 T_{HYST} AND T_{OS} REGISTER (Read/Write):

D15	D14	D13	D12	D11	D10	D9	D8	D7	D6	D5	D4	D3	D2	D1	D0
MSB	Bit 7	Bit 6	Bit 5	Bit 4	Bit 3	Bit 2	Bit 1	LSB	X	X	X	X	X	X	X

D0–D6: Undefined

D7–D15: T_{HYST} Or T_{OS} Trip Temperature Data. Power up default is T_{OS} = 80°C, T_{HYST} = 75°C.

2.0 I²C[®] Timing Diagrams

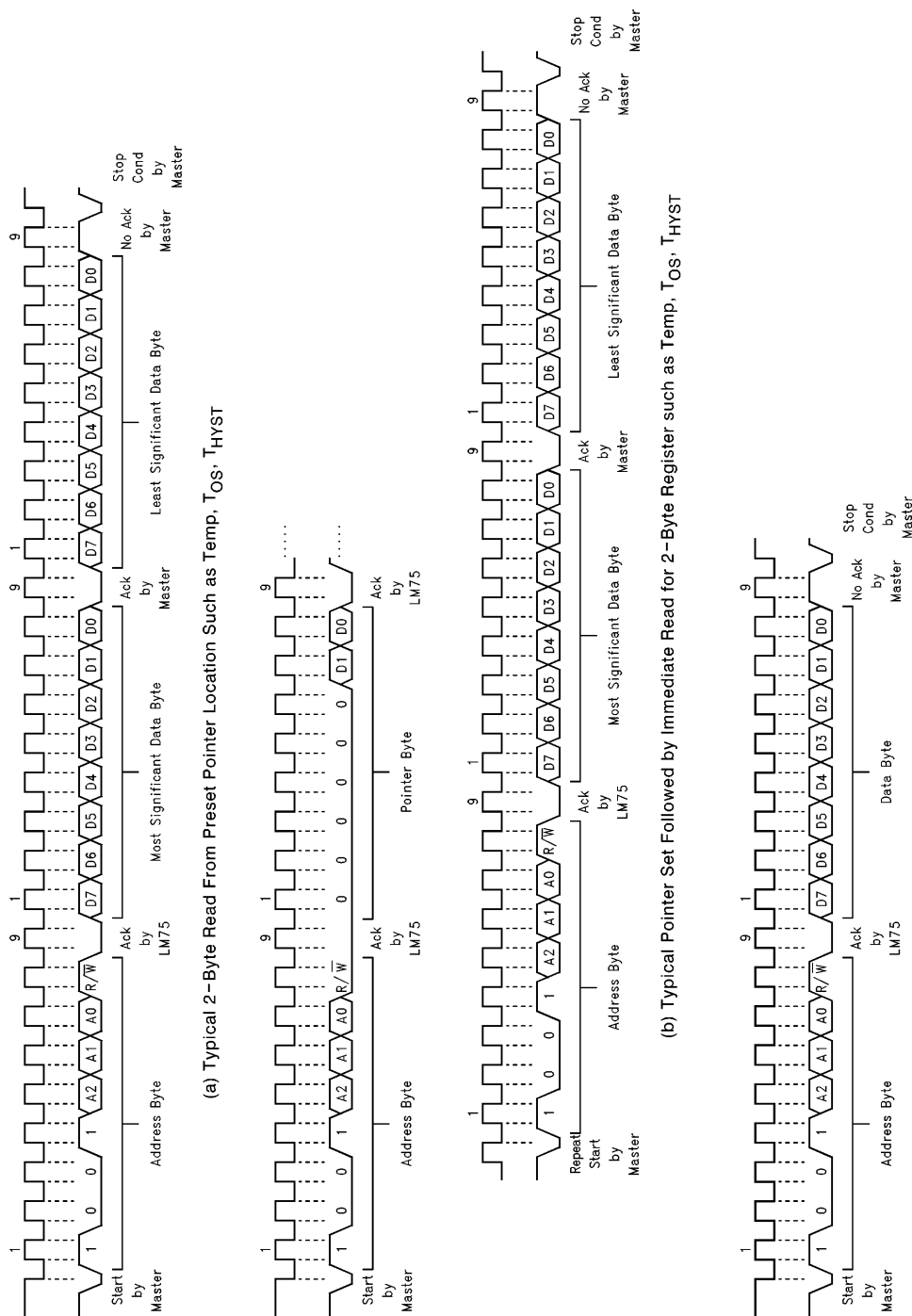
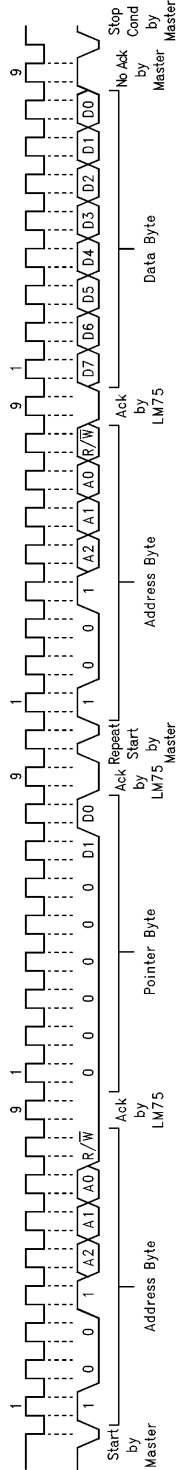

FIGURE 6. Timing Diagram

TL/H/12658-10

2.0 I²C[®] Timing Diagrams (Continued)



(a) Typical Pointer Set Followed by Immediate Read from Configuration Register

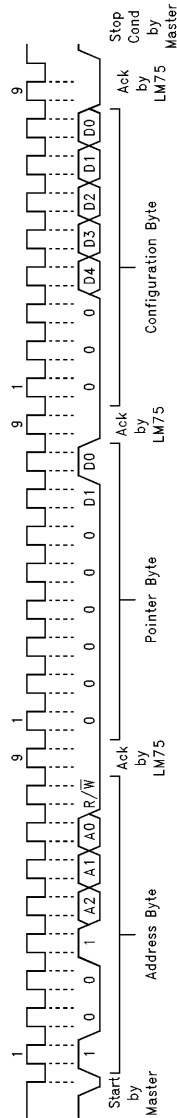

(b) Configuration Register Write

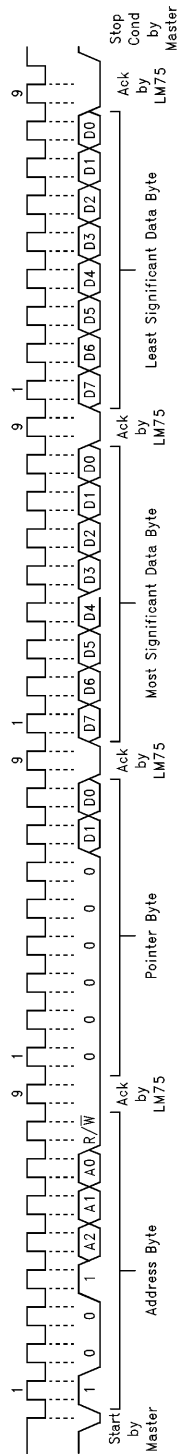

(c) T_{OS} and T_{HYST} Write
 TL/H/12658-11
 FIGURE 7. Timing Diagrams (Continued)

3.0 Application Hints

The LM75 can be applied easily in the same way as other integrated-circuit temperature sensors. It can be glued or cemented to a surface and its temperature will be within about 0.2°C of the surface temperature.

This presumes that the ambient air temperature is almost the same as the surface temperature; if the air temperature were much higher or lower than the surface temperature, the actual temperature of the LM75 die would be at an intermediate temperature between the surface temperature and the air temperature.

The path of best thermal conductivity is between the die and the GND pin, upon which the die is mounted. The printed-circuit board lands and traces connecting to the LM75 will be the object whose temperature is being measured.

In probe type applications, the LM75 can be mounted inside a sealed-end metal tube, and can then be dipped into a bath or screwed into a threaded hole in a tank. As with any IC, the LM75 and accompanying wiring and circuits must be kept insulated and dry, to avoid leakage and corrosion. This is especially true if the circuit may operate at cold temperatures where condensation can occur. Printed-circuit coatings and varnishes such as Humiseal and epoxy paints or dips are often used to insure that moisture cannot corrode the LM75 or its connections.

Typical Applications

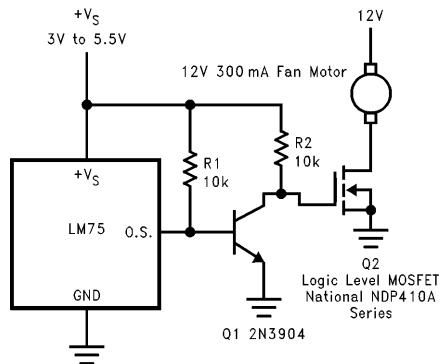

TL/H/12658-12

When using the two-wire interface: program O.S. for active high and connect O.S. directly to Q2's gate.

FIGURE 8. Simple Fan Controller, Interface Optional

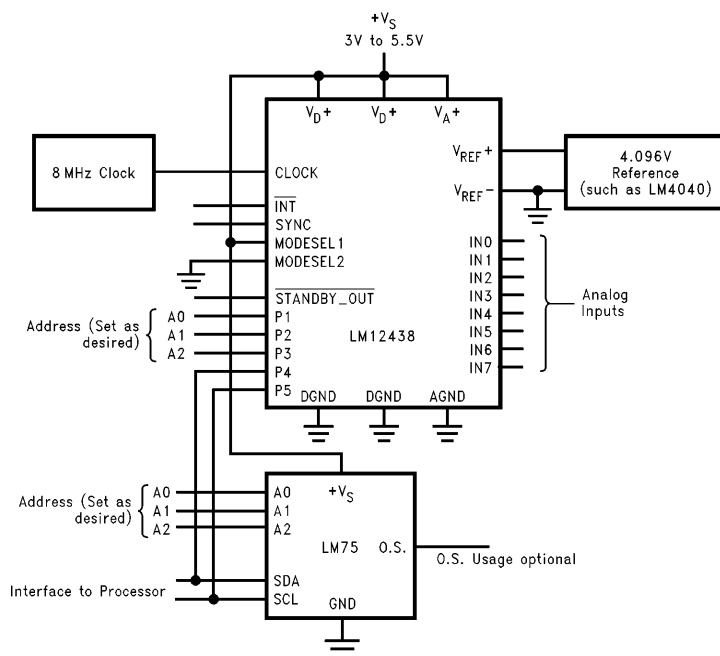

TL/H/12658-13

FIGURE 9. Data Acquisition System with Temperature Input via I²C® Bus

Typical Applications (Continued)

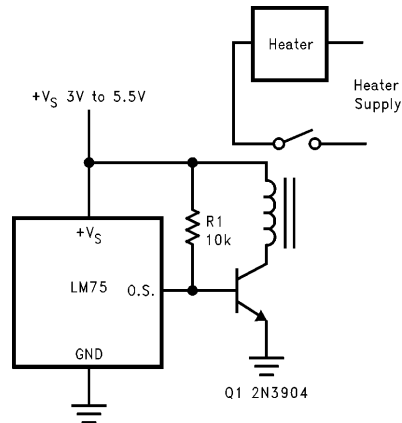

TL/H/12658-14

FIGURE 10. Simple Thermostat, Interface Optional

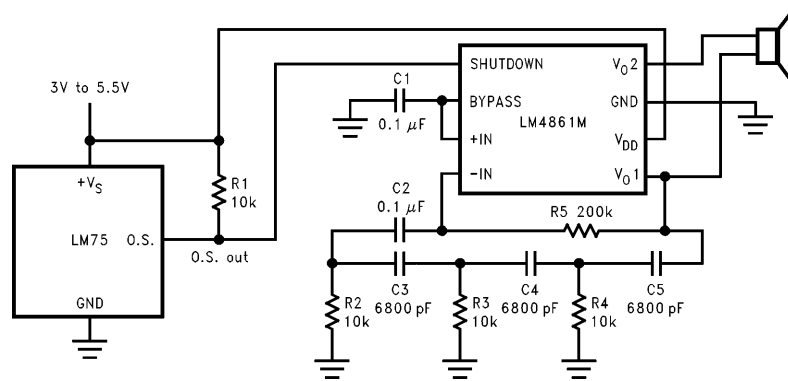

TL/H/12658-15

FIGURE 11. Temperature Sensor with Loudmouth Alarm (Barking Watchdog)

Physical Dimensions inches (millimeters) unless otherwise noted

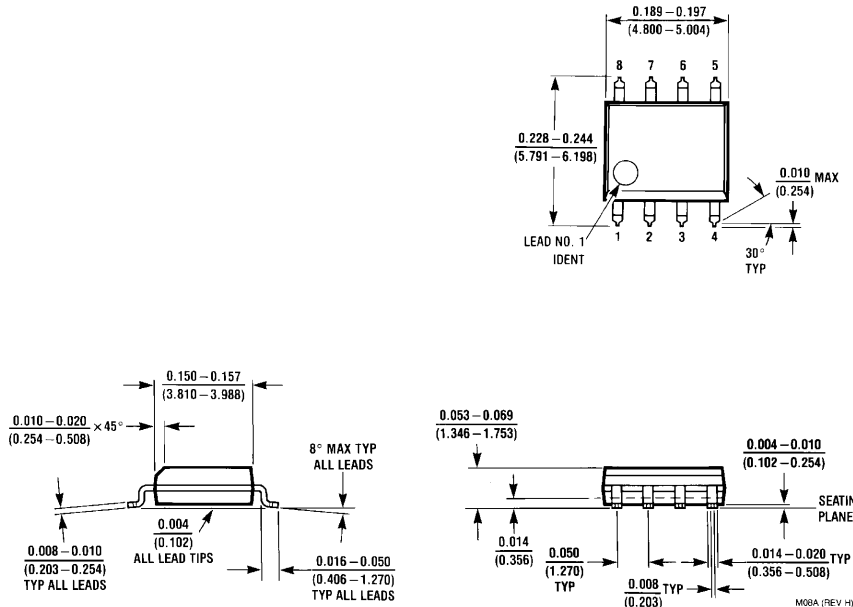

**8-Lead (0.150" Wide) Molded Small Outline Package, JEDEC
Order Number LM75CIM-3, LM75CIMX-3, LM75CIM-5 or LM75CIMX-5
NS Package Number M08A**

LIFE SUPPORT POLICY

NATIONAL'S PRODUCTS ARE NOT AUTHORIZED FOR USE AS CRITICAL COMPONENTS IN LIFE SUPPORT DEVICES OR SYSTEMS WITHOUT THE EXPRESS WRITTEN APPROVAL OF THE PRESIDENT OF NATIONAL SEMICONDUCTOR CORPORATION. As used herein:

1. Life support devices or systems are devices or systems which, (a) are intended for surgical implant into the body, or (b) support or sustain life, and whose failure to perform, when properly used in accordance with instructions for use provided in the labeling, can be reasonably expected to result in a significant injury to the user.
2. A critical component is any component of a life support device or system whose failure to perform can be reasonably expected to cause the failure of the life support device or system, or to affect its safety or effectiveness.



National Semiconductor Corporation
1111 West Bardin Road
Arlington, TX 76017
Tel: (800) 272-9959
Fax: (800) 737-7018

<http://www.national.com>

National Semiconductor Europe

Fax: +49 (0) 180-530 85 86
Email: europe.support@nsc.com
Deutsch Tel: +49 (0) 180-530 85 85
English Tel: +49 (0) 180-532 78 32
Français Tel: +49 (0) 180-532 93 58
Italiano Tel: +49 (0) 180-534 16 80

National Semiconductor Hong Kong Ltd.

19th Floor, Straight Block,
Ocean Centre, 5 Canton Rd.
Tsimshatsui, Kowloon
Hong Kong
Tel: (852) 2737-1600
Fax: (852) 2736-9960

National Semiconductor Japan Ltd.

Tel: 81-043-299-2308
Fax: 81-043-299-2408

National does not assume any responsibility for use of any circuitry described, no circuit patent licenses are implied and National reserves the right at any time without notice to change said circuitry and specifications.