

LMT85 SC70, Analog Temperature Sensor with Class-AB Output

Check for Samples: [LMT85](#)

FEATURES

- Push-Pull Output with 50 μ A Source Current Capability
- Very Accurate Over Wide Temperature Range of -50°C to 150°C
- Low Quiescent Current
- Output is Short-Circuit Protected
- Extremely Small SC70 Package
- Cost-effective Alternative to Thermistors

APPLICATIONS

- Automotive
- Industrial
- White Goods
- Battery Management
- Disk Drives
- Appliances
- Games
- Wireless Transceivers
- Cell phones

DESCRIPTION

The LMT85 is a precision analog output CMOS integrated-circuit temperature sensor that operates at a supply voltage as low as 1.8 Volts. A class-AB output structure gives the LMT85 strong output source and sink current capability for driving heavy loads. This means it is well suited to source the input of a sample-and-hold analog-to-digital converter with its transient load requirements. While operating over the wide temperature range of -50°C to 150°C , the device delivers an output voltage that is inversely proportional to measured temperature. The LMT85 low supply current makes it ideal for battery-powered systems as well as general temperature sensing applications.

The LMT85 can operate with a 1.8V supply while measuring temperature over the full -50°C to 150°C operating range.

The LMT85 is a cost-competitive alternative to thermistors.

CONNECTION DIAGRAM

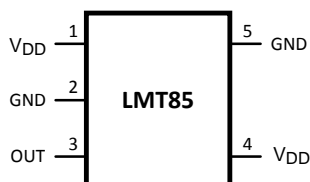
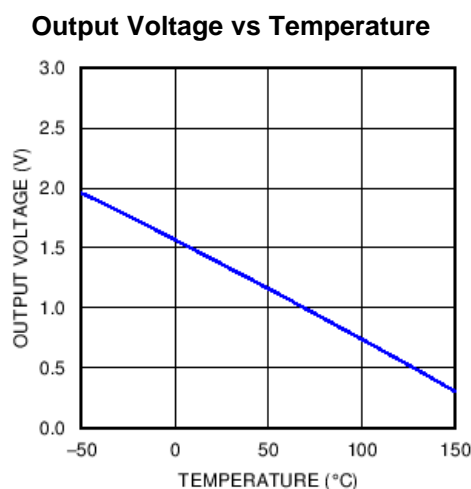

Figure 1. SOT Top View
See Package Number DCK0005A

TYPICAL TRANSFER CHARACTERISTIC



Please be aware that an important notice concerning availability, standard warranty, and use in critical applications of Texas Instruments semiconductor products and disclaimers thereto appears at the end of this data sheet.

All trademarks are the property of their respective owners.



These devices have limited built-in ESD protection. The leads should be shorted together or the device placed in conductive foam during storage or handling to prevent electrostatic damage to the MOS gates.

TYPICAL APPLICATION

Full-Range Celsius Temperature Sensor (-50°C to 150°C)

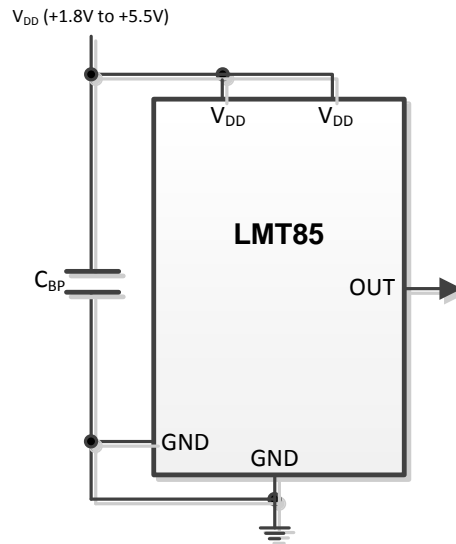

PIN DESCRIPTIONS

LABEL	PIN NUMBER	TYPE	EQUIVALENT CIRCUIT	FUNCTION
GND	5	Ground		Power Supply Ground
V _{DD}	1	Power		Positive Supply Voltage
OUT	3	Analog Output		Outputs a voltage which is inversely proportional to temperature
V _{DD}	4	Power		Positive Supply Voltage
GND	2	Ground		Power Supply Ground

ABSOLUTE MAXIMUM RATINGS ⁽¹⁾

	VALUE		UNIT	
	MIN	MAX		
Supply Voltage	-0.3	6.	V	
Voltage at Output Pin	-0.3	(V _{DD} + 0.5)	V	
Output Current		±7	mA	
Input Current at any pin ⁽²⁾		5	mA	
Storage Temperature	-65	150	°C	
Maximum Junction Temperature (T _{JMAX})		150	°C	
ESD Susceptibility ⁽³⁾ :	Human Body Model		2500	V
	Machine Model		250	V
Soldering process must comply with Texas Instruments Reflow Temperature Profile specifications. Refer to www.ti.com/packaging . ⁽⁴⁾				

- (1) Absolute Maximum Ratings indicate limits beyond which damage to the device may occur. Operating Ratings indicate conditions for which the device is functional, but do not specify performance limits. For specifications and test conditions, see the Electrical Characteristics. The specifications apply only for the test conditions listed. Some performance characteristics may degrade when the device is not operated under the listed test conditions.
- (2) When the input voltage (V_I) at any pin exceeds power supplies (V_I < GND or V_I > V), the current at that pin should be limited to 5 mA.
- (3) The human body model is a 100 pF capacitor discharged through a 1.5 kΩ resistor into each pin. The machine model is a 200 pF capacitor discharged directly into each pin.
- (4) Reflow temperature profiles are different for lead-free and non-lead-free packages.

OPERATING RATINGS

	VALUE	UNIT
Specified Temperature Range:	T _{MIN} ≤ T _A ≤ T _{MAX}	°C
	-50 ≤ T _A ≤ +150	°C
Supply Voltage Range (V _{DD})	1.8 to 5.5	V
Thermal Resistance (θ _{JA}) ⁽¹⁾⁽²⁾ (SOT)	415	°C/W

- (1) The junction to ambient thermal resistance (θ_{JA}) is specified without a heat sink in still air.
- (2) Changes in output due to self heating can be computed by multiplying the internal dissipation by the thermal resistance.

ACCURACY CHARACTERISTICS

These limits do not include DC load regulation. These stated accuracy limits are with reference to the values in [Table 1](#).

PARAMETER	CONDITIONS	TYPICAL	LIMITS ⁽¹⁾	UNIT
Temperature Error ⁽²⁾	70°C to 150°C; V _{DD} = 1.9 V to 5.5 V	0.4	2.7	°C
	0°C to 150°C; V _{DD} = 1.9 V to 5.5 V	0.7	2.7	°C
	0°C to 150°C; V _{DD} = 2.6 V to 5.5 V	0.3		°C
	-50°C to 0°C; V _{DD} = 2.3 V to 5.5 V	0.7	2.7	°C
	-50°C to 0°C; V _{DD} = 2.9 V to 5.5 V	0.25		°C

- (1) Limits are specific to TI's AOQL (Average Outgoing Quality Level).
- (2) Accuracy is defined as the error between the measured and reference output voltages, tabulated in the Transfer Table at the specified conditions of supply gain setting, voltage, and temperature (expressed in °C). Accuracy limits include line regulation within the specified conditions. Accuracy limits do not include load regulation; they assume no DC load.

ELECTRICAL CHARACTERISTICS

Unless otherwise noted, these specifications apply for $+V_{DD} = 1.8V$ to $5.5V$. **Boldface limits apply for $T_A = T_J = T_{MIN}$ to T_{MAX}** ; all other limits $T_A = T_J = 25^\circ C$.

PARAMETER		CONDITIONS	TYPICAL ⁽¹⁾	MAX ⁽²⁾	UNITS
	Sensor Gain		-8.2		mV/°C
	Load Regulation ⁽³⁾	Source $\leq 50 \mu A$, $(V_{DD} - V_{OUT}) \geq 200$ mV	-0.22	-1	mV
		Sink $\leq 50 \mu A$, $V_{OUT} \geq 200$ mV	0.26	1	mV
	Line Regulation ⁽⁴⁾		200		$\mu V/V$
I_S	Supply Current ⁽⁵⁾	$T_A = 30^\circ C$ to $150^\circ C$, $(V_{DD} - V_{OUT}) \geq 100$ mV	5.4	8.1	μA
		$T_A = -50^\circ C$ to $150^\circ C$, $(V_{DD} - V_{OUT}) \geq 100$ mV	5.4	9	μA
C_L	Output Load Capacitance		1100		pF
	Power-on Time ⁽⁶⁾	$C_L = 0$ pF to 1100 pF	0.7	1.9	ms
	Output drive			± 50	μA

(1) Typicals are at $T_J = T_A = 25^\circ C$ and represent most likely parametric norm.

(2) Limits are specific to TI's AOQL (Average Outgoing Quality Level).

(3) Source currents are flowing out of the LMT85. Sink currents are flowing into the LMT85.

(4) Line regulation (DC) is calculated by subtracting the output voltage at the highest supply voltage from the output voltage at the lowest supply voltage. The typical DC line regulation specification does not include the output voltage shift discussed in [OUTPUT VOLTAGE SHIFT](#).

(5) The input current is leakage only and is highest at high temperature. It is typically only $0.001 \mu A$. The $1 \mu A$ limit is solely based on a testing limitation and does not reflect the actual performance of the part.

(6) Specified by design and characterization.

TYPICAL PERFORMANCE CHARACTERISTICS

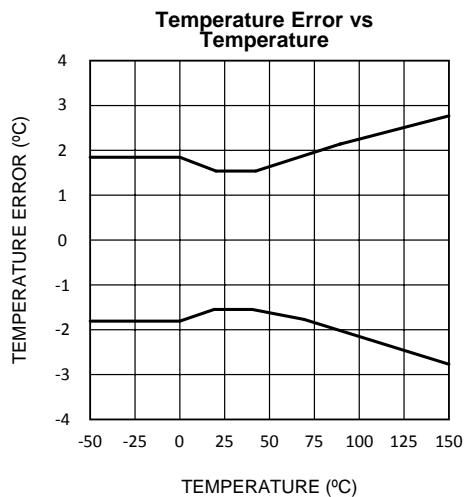

Figure 2.

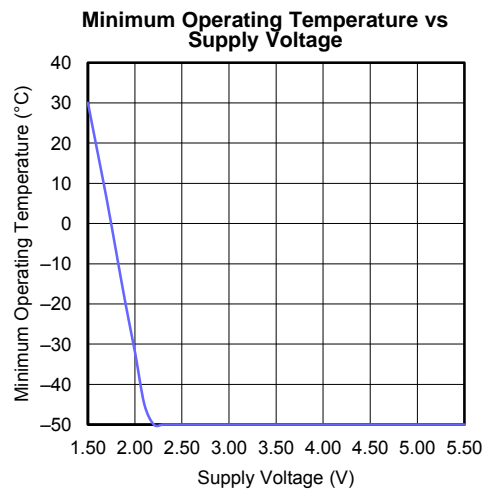

Figure 3.

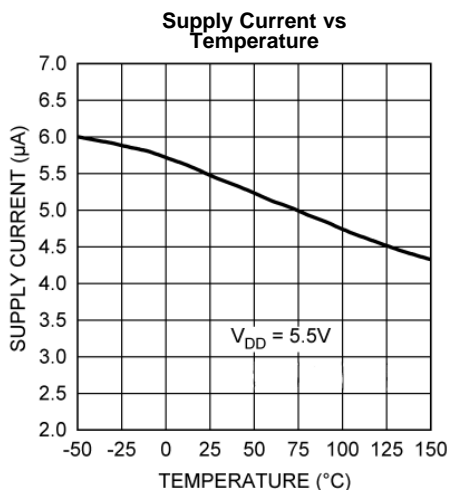

Figure 4.

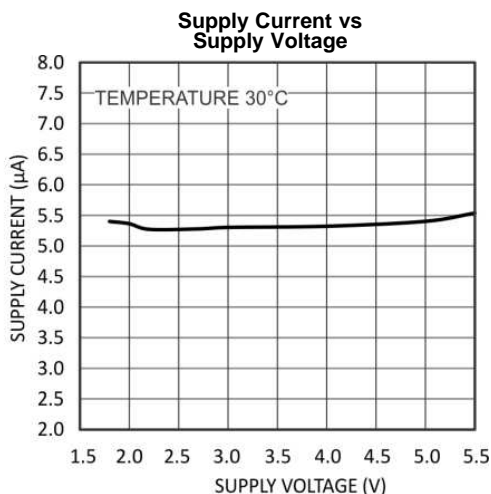

Figure 5.

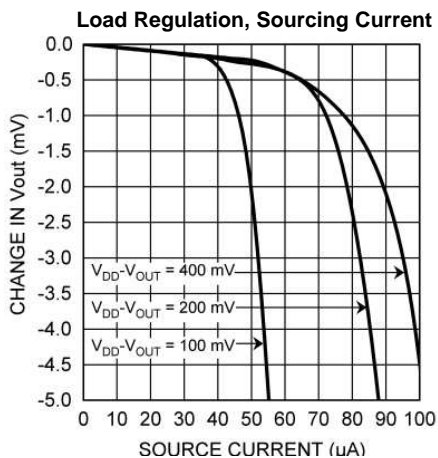

Figure 6.

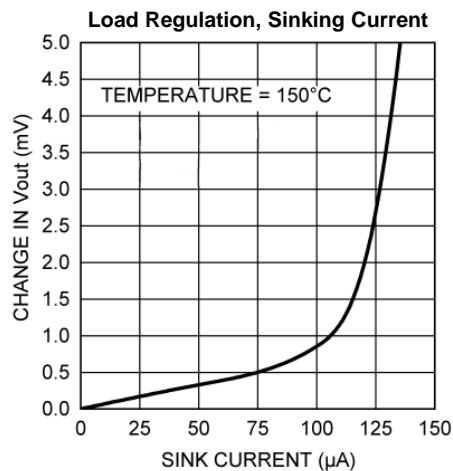

Figure 7.

TYPICAL PERFORMANCE CHARACTERISTICS (continued)

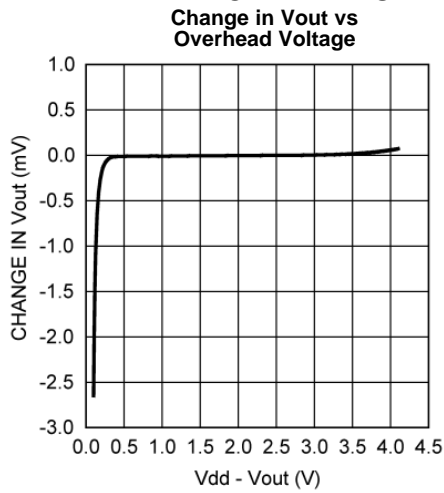

Figure 8.

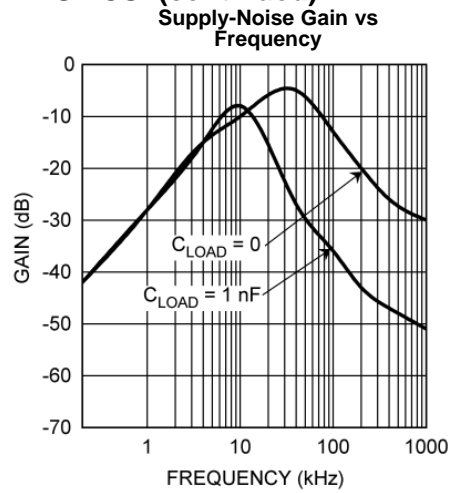

Figure 9.

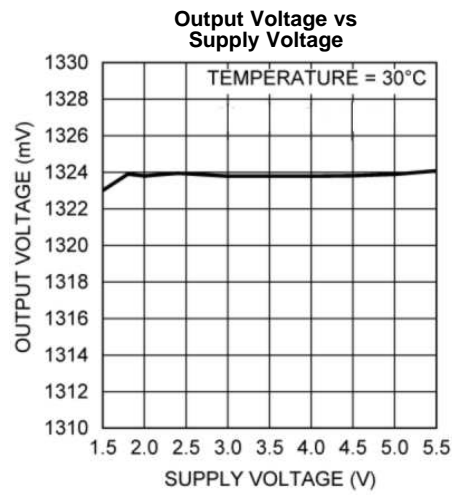

Figure 10.

LMT85 TRANSFER FUNCTION

The output voltage of the LMT85, across the complete operating temperature range, is shown in [Table 1](#). This table is the reference from which the LMT85 accuracy specifications (listed in the [ELECTRICAL CHARACTERISTICS](#) section) are determined. This table can be used, for example, in a host processor look-up table. A file containing this data is available for download at www.ti.com

Table 1. LMT85 Transfer Table⁽¹⁾

TEMP (°C)	V _{OUT} (mV)	TEMP (°C)	V _{OUT} (mV)	TEMP (°C)	V _{OUT} (mV)	TEMP (°C)	V _{OUT} (mV)	TEMP (°C)	V _{OUT} (mV)
-50	1955	-10	1648	30	1324	70	991	110	651
-49	1949	-9	1639	31	1316	71	983	111	642
-48	1942	-8	1631	32	1308	72	974	112	634
-47	1935	-7	1623	33	1299	73	966	113	625
-46	1928	-6	1615	34	1291	74	957	114	617
-45	1921	-5	1607	35	1283	75	949	115	608
-44	1915	-4	1599	36	1275	76	941	116	599
-43	1908	-3	1591	37	1267	77	932	117	591
-42	1900	-2	1583	38	1258	78	924	118	582
-41	1892	-1	1575	39	1250	79	915	119	573
-40	1885	0	1567	40	1242	80	907	120	565
-39	1877	1	1559	41	1234	81	898	121	556
-38	1869	2	1551	42	1225	82	890	122	547
-37	1861	3	1543	43	1217	83	881	123	539
-36	1853	4	1535	44	1209	84	873	124	530
-35	1845	5	1527	45	1201	85	865	125	521
-34	1838	6	1519	46	1192	86	856	126	513
-33	1830	7	1511	47	1184	87	848	127	504
-32	1822	8	1502	48	1176	88	839	128	495
-31	1814	9	1494	49	1167	89	831	129	487
-30	1806	10	1486	50	1159	90	822	130	478
-29	1798	11	1478	51	1151	91	814	131	469
-28	1790	12	1470	52	1143	92	805	132	460
-27	1783	13	1462	53	1134	93	797	133	452
-26	1775	14	1454	54	1126	94	788	134	443
-25	1767	15	1446	55	1118	95	779	135	434
-24	1759	16	1438	56	1109	96	771	136	425
-23	1751	17	1430	57	1101	97	762	137	416
-22	1743	18	1421	58	1093	98	754	138	408
-21	1735	19	1413	59	1084	99	745	139	399
-20	1727	20	1405	60	1076	100	737	140	390
-19	1719	21	1397	61	1067	101	728	141	381
-18	1711	22	1389	62	1059	102	720	142	372
-17	1703	23	1381	63	1051	103	711	143	363
-16	1695	24	1373	64	1042	104	702	144	354
-15	1687	25	1365	65	1034	105	694	145	346
-14	1679	26	1356	66	1025	106	685	146	337
-13	1671	27	1348	67	1017	107	677	147	328
-12	1663	28	1340	68	1008	108	668	148	319
-11	1656	29	1332	69	1000	109	660	149	310
								150	301

(1) The output voltages in this table apply for V_{DD} = 5V.

Although the LMT85 is very linear, its response does have a slight downward parabolic shape. This shape is very accurately reflected in [Table 1](#). For a linear approximation, a line can easily be calculated over the desired temperature range from the Table using the two-point equation:

$$V - V_1 = \left(\frac{V_2 - V_1}{T_2 - T_1} \right) \times (T - T_1) \quad (1)$$

Where V is in mV, T is in °C, T_1 and V_1 are the coordinates of the lowest temperature, T_2 and V_2 are the coordinates of the highest temperature.

For example, if we want to resolve this equation, over a temperature range of 20°C to 50°C, we would proceed as follows:

$$V - 1405 \text{ mV} = \left(\frac{1159 \text{ mV} - 1405 \text{ mV}}{50^\circ\text{C} - 20^\circ\text{C}} \right) \times (T - 20^\circ\text{C}) \quad (2)$$

$$V - 1405 \text{ mV} = (-8.20 \text{ mV} / ^\circ\text{C}) \times (T - 20^\circ\text{C}) \quad (3)$$

$$V = (-8.20 \text{ mV} / ^\circ\text{C}) \times T + 1569 \text{ mV} \quad (4)$$

Using this method of linear approximation, the transfer function can be approximated for one or more temperature ranges of interest.

MOUNTING AND THERMAL CONDUCTIVITY

The LMT85 can be applied easily in the same way as other integrated-circuit temperature sensors. It can be glued or cemented to a surface.

To ensure good thermal conductivity, the backside of the LMT85 die is directly attached to the GND pin (Pin 2). The temperatures of the lands and traces to the other leads of the LMT85 will also affect the temperature reading.

Alternatively, the LMT85 can be mounted inside a sealed-end metal tube, and can then be dipped into a bath or screwed into a threaded hole in a tank. As with any IC, the LMT85 and accompanying wiring and circuits must be kept insulated and dry, to avoid leakage and corrosion. This is especially true if the circuit may operate at cold temperatures where condensation can occur. If moisture creates a short circuit from the output to ground or V_{DD} , the output from the LMT85 will not be correct. Printed-circuit coatings are often used to ensure that moisture cannot corrode the leads or circuit traces.

The thermal resistance junction to ambient (θ_{JA}) is the parameter used to calculate the rise of a device junction temperature due to its power dissipation. The equation used to calculate the rise in the LMT85 die temperature is:

$$T_J = T_A + \theta_{JA} [(V_{DD} I_S) + (V_{DD} - V_{OUT}) I_L] \quad (5)$$

where T_A is the ambient temperature, I_S is the supply current, I_L is the load current on the output, and V_O is the output voltage. For example, in an application where $T_A = 30^\circ\text{C}$, $V_{DD} = 5 \text{ V}$, $I_S = 5.4 \mu\text{A}$, $V_{OUT} = 1324 \text{ mV}$, and $I_L = 2 \mu\text{A}$, the junction temperature would be 30.0143°C , showing a self-heating error of only 0.0143°C . Since the LMT85's junction temperature is the actual temperature being measured, care should be taken to minimize the load current that the LMT85 is required to drive. [Table 2](#) shows the thermal resistance of the LMT85.

Table 2. LMT85 Thermal Resistance

DEVICE NUMBER	TI PACKAGE NUMBER	THERMAL RESISTANCE (θ_{JA})
LMT85DCK	DCK0005A	415°C/W

OUTPUT AND NOISE CONSIDERATIONS

A push-pull output gives the LMT85 the ability to sink and source significant current. This is beneficial when, for example, driving dynamic loads like an input stage on an analog-to-digital converter (ADC). In these applications the source current is required to quickly charge the input capacitor of the ADC. See the [APPLICATION CIRCUITS](#) section for more discussion of this topic. The LMT85 is ideal for this and other applications which require strong source or sink current.

The LMT85's supply-noise gain (the ratio of the AC signal on V_{OUT} to the AC signal on V_{DD}) was measured during bench tests. Its typical attenuation is shown in the [TYPICAL PERFORMANCE CHARACTERISTICS](#) section. A load capacitor on the output can help to filter noise.

For operation in very noisy environments, some bypass capacitance should be present on the supply within approximately 5 centimeters of the LMT85.

CAPACITIVE LOADS

The LMT85 handles capacitive loading well. In an extremely noisy environment, or when driving a switched sampling input on an ADC, it may be necessary to add some filtering to minimize noise coupling. Without any precautions, the LMT85 can drive a capacitive load less than or equal to 1100 pF as shown in [Figure 11](#). For capacitive loads greater than 1100 pF, a series resistor may be required on the output, as shown in [Figure 12](#).

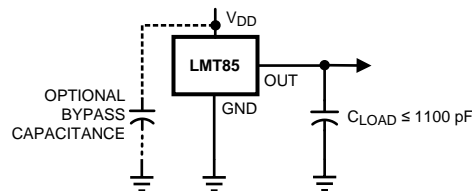

Figure 11. LMT85 No Decoupling Required for Capacitive Loads Less than 1100 pF

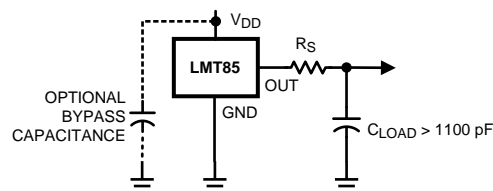

Figure 12. LMT85 with Series Resistor for Capacitive Loading Greater than 1100 pF

C_{LOAD}	MINIMUM R_S
1.1 nF to 99 nF	3 k Ω
100 nF to 999 nF	1.5 k Ω
1 μ F	800 Ω

OUTPUT VOLTAGE SHIFT

The LMT85 is very linear over temperature and supply voltage range. Due to the intrinsic behavior of an NMOS/PMOS rail-to-rail buffer, a slight shift in the output can occur when the supply voltage is ramped over the operating range of the device. The location of the shift is determined by the relative levels of V_{DD} and V_{OUT} . The shift typically occurs when $V_{DD} - V_{OUT} = 1$ V.

This slight shift (a few millivolts) takes place over a wide change (approximately 200 mV) in V_{DD} or V_{OUT} . Since the shift takes place over a wide temperature change of 5°C to 20°C, V_{OUT} is always monotonic. The accuracy specifications in the [ELECTRICAL CHARACTERISTICS](#) table already include this possible shift.

APPLICATION CIRCUITS

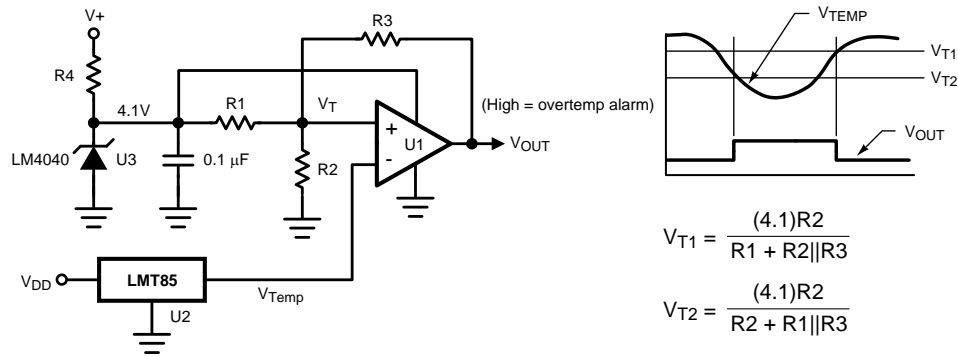

Figure 13. Celsius Thermostat

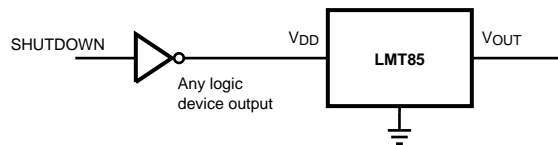
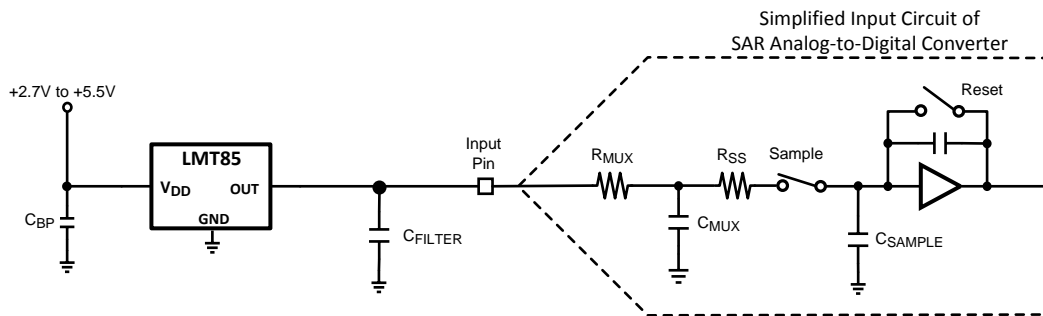

Figure 14. Conserving Power Dissipation with Shutdown



Most CMOS ADCs found in microcontrollers and ASICs have a sampled data comparator input structure. When the ADC charges the sampling cap, it requires instantaneous charge from the output of the analog source such as the LMT85 temperature sensor and many op amps. This requirement is easily accommodated by the addition of a capacitor (C_{FILTER}). The size of C_{FILTER} depends on the size of the sampling capacitor and the sampling frequency. Since not all ADCs have identical input stages, the charge requirements will vary. This general ADC application is shown as an example only.

Figure 15. Suggested Connection to a Sampling Analog-to-Digital Converter Input Stage

PACKAGING INFORMATION

Orderable Device	Status (1)	Package Type	Package Drawing	Pins	Package Qty	Eco Plan (2)	Lead/Ball Finish	MSL Peak Temp (3)	Op Temp (°C)	Top-Side Markings (4)	Samples
LMT85DCKR	PREVIEW	SC70	DCK	5	3000	Green (RoHS & no Sb/Br)	CU SN	Level-1-260C-UNLIM	-50 to 150		
LMT85DCKT	PREVIEW	SC70	DCK	5	250	Green (RoHS & no Sb/Br)	CU SN	Level-1-260C-UNLIM	-50 to 150		

(1) The marketing status values are defined as follows:

ACTIVE: Product device recommended for new designs.

LIFEBUY: TI has announced that the device will be discontinued, and a lifetime-buy period is in effect.

NRND: Not recommended for new designs. Device is in production to support existing customers, but TI does not recommend using this part in a new design.

PREVIEW: Device has been announced but is not in production. Samples may or may not be available.

OBSOLETE: TI has discontinued the production of the device.

(2) Eco Plan - The planned eco-friendly classification: Pb-Free (RoHS), Pb-Free (RoHS Exempt), or Green (RoHS & no Sb/Br) - please check <http://www.ti.com/productcontent> for the latest availability information and additional product content details.

TBD: The Pb-Free/Green conversion plan has not been defined.

Pb-Free (RoHS): TI's terms "Lead-Free" or "Pb-Free" mean semiconductor products that are compatible with the current RoHS requirements for all 6 substances, including the requirement that lead not exceed 0.1% by weight in homogeneous materials. Where designed to be soldered at high temperatures, TI Pb-Free products are suitable for use in specified lead-free processes.

Pb-Free (RoHS Exempt): This component has a RoHS exemption for either 1) lead-based flip-chip solder bumps used between the die and package, or 2) lead-based die adhesive used between the die and leadframe. The component is otherwise considered Pb-Free (RoHS compatible) as defined above.

Green (RoHS & no Sb/Br): TI defines "Green" to mean Pb-Free (RoHS compatible), and free of Bromine (Br) and Antimony (Sb) based flame retardants (Br or Sb do not exceed 0.1% by weight in homogeneous material)

(3) MSL, Peak Temp. -- The Moisture Sensitivity Level rating according to the JEDEC industry standard classifications, and peak solder temperature.

(4) Only one of markings shown within the brackets will appear on the physical device.

Important Information and Disclaimer: The information provided on this page represents TI's knowledge and belief as of the date that it is provided. TI bases its knowledge and belief on information provided by third parties, and makes no representation or warranty as to the accuracy of such information. Efforts are underway to better integrate information from third parties. TI has taken and continues to take reasonable steps to provide representative and accurate information but may not have conducted destructive testing or chemical analysis on incoming materials and chemicals. TI and TI suppliers consider certain information to be proprietary, and thus CAS numbers and other limited information may not be available for release.

In no event shall TI's liability arising out of such information exceed the total purchase price of the TI part(s) at issue in this document sold by TI to Customer on an annual basis.

DCK (R-PDSO-G5)

PLASTIC SMALL-OUTLINE PACKAGE

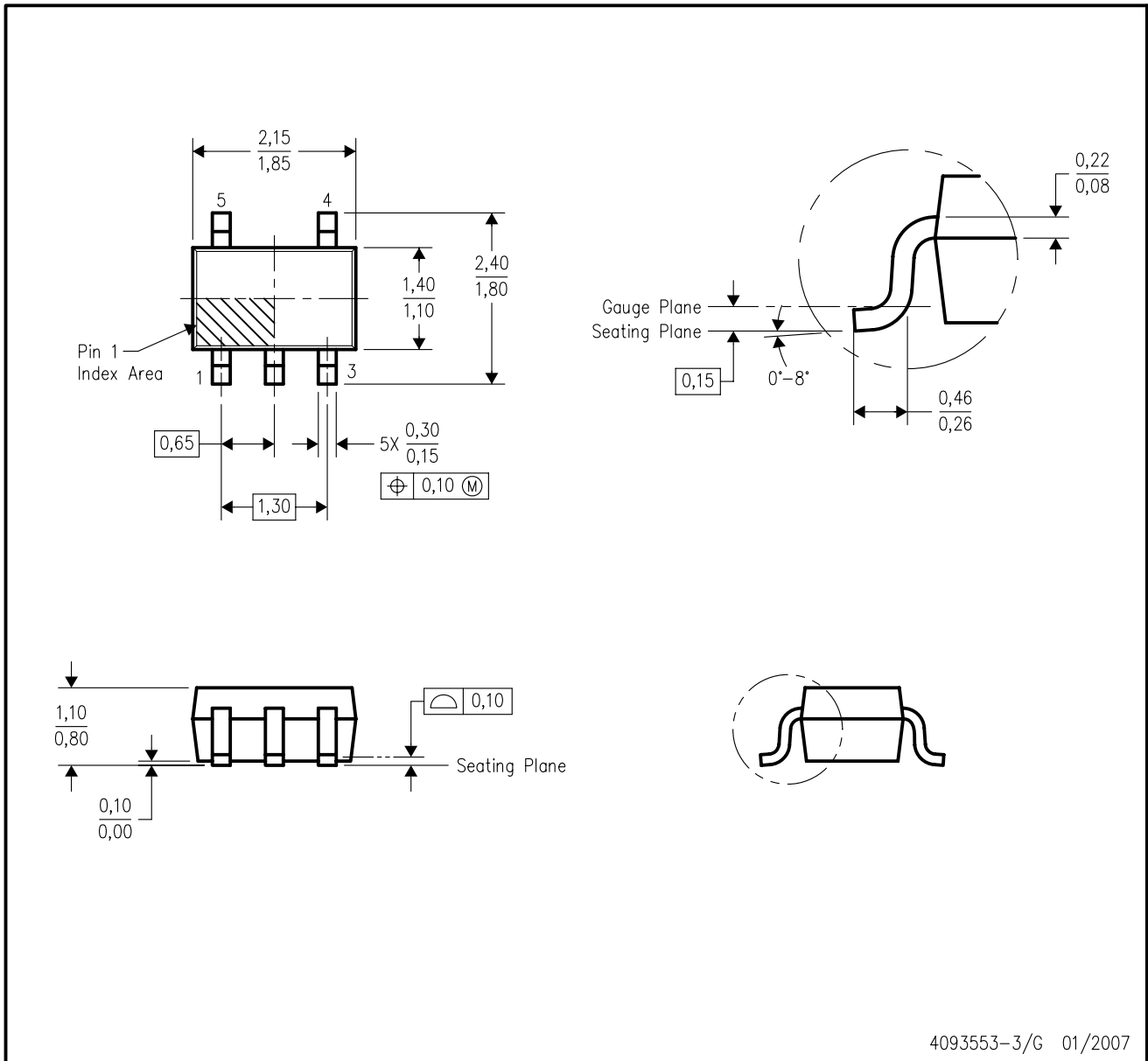

- NOTES:
- A. All linear dimensions are in millimeters.
 - B. This drawing is subject to change without notice.
 - C. Body dimensions do not include mold flash or protrusion. Mold flash and protrusion shall not exceed 0.15 per side.
 - D. Falls within JEDEC MO-203 variation AA.

IMPORTANT NOTICE

Texas Instruments Incorporated and its subsidiaries (TI) reserve the right to make corrections, enhancements, improvements and other changes to its semiconductor products and services per JESD46, latest issue, and to discontinue any product or service per JESD48, latest issue. Buyers should obtain the latest relevant information before placing orders and should verify that such information is current and complete. All semiconductor products (also referred to herein as "components") are sold subject to TI's terms and conditions of sale supplied at the time of order acknowledgment.

TI warrants performance of its components to the specifications applicable at the time of sale, in accordance with the warranty in TI's terms and conditions of sale of semiconductor products. Testing and other quality control techniques are used to the extent TI deems necessary to support this warranty. Except where mandated by applicable law, testing of all parameters of each component is not necessarily performed.

TI assumes no liability for applications assistance or the design of Buyers' products. Buyers are responsible for their products and applications using TI components. To minimize the risks associated with Buyers' products and applications, Buyers should provide adequate design and operating safeguards.

TI does not warrant or represent that any license, either express or implied, is granted under any patent right, copyright, mask work right, or other intellectual property right relating to any combination, machine, or process in which TI components or services are used. Information published by TI regarding third-party products or services does not constitute a license to use such products or services or a warranty or endorsement thereof. Use of such information may require a license from a third party under the patents or other intellectual property of the third party, or a license from TI under the patents or other intellectual property of TI.

Reproduction of significant portions of TI information in TI data books or data sheets is permissible only if reproduction is without alteration and is accompanied by all associated warranties, conditions, limitations, and notices. TI is not responsible or liable for such altered documentation. Information of third parties may be subject to additional restrictions.

Resale of TI components or services with statements different from or beyond the parameters stated by TI for that component or service voids all express and any implied warranties for the associated TI component or service and is an unfair and deceptive business practice. TI is not responsible or liable for any such statements.

Buyer acknowledges and agrees that it is solely responsible for compliance with all legal, regulatory and safety-related requirements concerning its products, and any use of TI components in its applications, notwithstanding any applications-related information or support that may be provided by TI. Buyer represents and agrees that it has all the necessary expertise to create and implement safeguards which anticipate dangerous consequences of failures, monitor failures and their consequences, lessen the likelihood of failures that might cause harm and take appropriate remedial actions. Buyer will fully indemnify TI and its representatives against any damages arising out of the use of any TI components in safety-critical applications.

In some cases, TI components may be promoted specifically to facilitate safety-related applications. With such components, TI's goal is to help enable customers to design and create their own end-product solutions that meet applicable functional safety standards and requirements. Nonetheless, such components are subject to these terms.

No TI components are authorized for use in FDA Class III (or similar life-critical medical equipment) unless authorized officers of the parties have executed a special agreement specifically governing such use.

Only those TI components which TI has specifically designated as military grade or "enhanced plastic" are designed and intended for use in military/aerospace applications or environments. Buyer acknowledges and agrees that any military or aerospace use of TI components which have **not** been so designated is solely at the Buyer's risk, and that Buyer is solely responsible for compliance with all legal and regulatory requirements in connection with such use.

TI has specifically designated certain components as meeting ISO/TS16949 requirements, mainly for automotive use. In any case of use of non-designated products, TI will not be responsible for any failure to meet ISO/TS16949.

Products

Audio	www.ti.com/audio
Amplifiers	amplifier.ti.com
Data Converters	dataconverter.ti.com
DLP® Products	www.dlp.com
DSP	dsp.ti.com
Clocks and Timers	www.ti.com/clocks
Interface	interface.ti.com
Logic	logic.ti.com
Power Mgmt	power.ti.com
Microcontrollers	microcontroller.ti.com
RFID	www.ti-rfid.com
OMAP Applications Processors	www.ti.com/omap
Wireless Connectivity	www.ti.com/wirelessconnectivity

Applications

Automotive and Transportation	www.ti.com/automotive
Communications and Telecom	www.ti.com/communications
Computers and Peripherals	www.ti.com/computers
Consumer Electronics	www.ti.com/consumer-apps
Energy and Lighting	www.ti.com/energy
Industrial	www.ti.com/industrial
Medical	www.ti.com/medical
Security	www.ti.com/security
Space, Avionics and Defense	www.ti.com/space-avionics-defense
Video and Imaging	www.ti.com/video

TI E2E Community

e2e.ti.com