

□ MN101C457

Type		MN101C457	
ROM (×8-bit)		16 K	
RAM (×8-bit)		0.5 K	
Package		QFP044-P-1010E *Lead-free	
Minimum Instruction Execution Time		0.10 μs (at 4.5 V to 5.5 V, 20 MHz) 0.238 μs (at 2.7 V to 5.5 V, 8.39 MHz) 0.477 μs (at 2.0 V to 5.5 V, 4.19 MHz)*	
* The lower limit for operation guarantee for EPROM built-in type is 2.7 V.			
Interrupts		• RESET • Watchdog • External 0 • External 1 • External 2 • Timer 2 • Timer 3 • Timer 4 • Timer 5 • Time base • Serial 0 • A/D conversion finish	
Timer Counter		<p>Timer counter 2 : 8-bit × 1 (square-wave/8-bit PWM output, event count, synchronous output event) Clock source 1/1, 1/4 of system clock frequency; external clock input Interrupt source coincidence with compare register 2</p> <p>Timer counter 3 : 8-bit × 1 (square-wave output, event count, generation of remote control carrier, serial 0 baud rate timer) Clock source 1/4, 1/16 of system clock frequency; 1/1 of OSC oscillation clock frequency; external clock input Interrupt source coincidence with compare register 3</p> <p>Timer counter 2, 3 can be cascade-connected.</p> <p>Timer counter 4 : 16-bit × 1 (square-wave/16-bit PWM output, event count, synchronous output event, input capture) Clock source 1/4, 1/16 of system clock frequency; 1/1 of OSC oscillation clock frequency; external clock input Interrupt source coincidence with compare register 4</p> <p>Time base timer (one-minute count setting, independently operable 8-bit timer counter 5) Clock source 1/4 of system clock frequency; 1/1, 1/8192 of OSC oscillation clock frequency Interrupt source coincidence with compare register 5; 1/8192 prescaler overflow</p> <p>Watchdog timer Interrupt source 1/65536, 1/262144, 1/1048576 of system clock frequency (ROM option)</p>	
Serial Interface		Serial 0 : synchronous type/simple UART (half-duplex) × 1 Clock source 1/2, 1/4, 1/16 of system clock frequency; pulse output of timer counter 3	
I/O Pins	I/O	26	• Common use: 16 • Specified pull-up resistor available • Input/output selectable (bit unit): 26
	Input	11	• Common use • Specified pull-up resistor available
A/D Inputs		10-bit × 8-ch. (with S/H)	
Special Ports		Buzzer output, remote control carrier signal output, high-current drive port	

Electrical Characteristics

Supply current

Parameter	Symbol	Condition	Limit			Unit
			min	typ	max	
Operating supply current	IDD1	fosc = 20 MHz, VDD = 5 V		15	40	mA
	IDD2	fosc = 8.39 MHz, VDD = 5 V		6	18	mA
Supply current at STOP	IDD3	VDD = 5 V, Ta = 25°C			2	μA
	IDD4	VDD = 5 V, Ta = -40°C to +85°C			20	μA

Pin Assignment

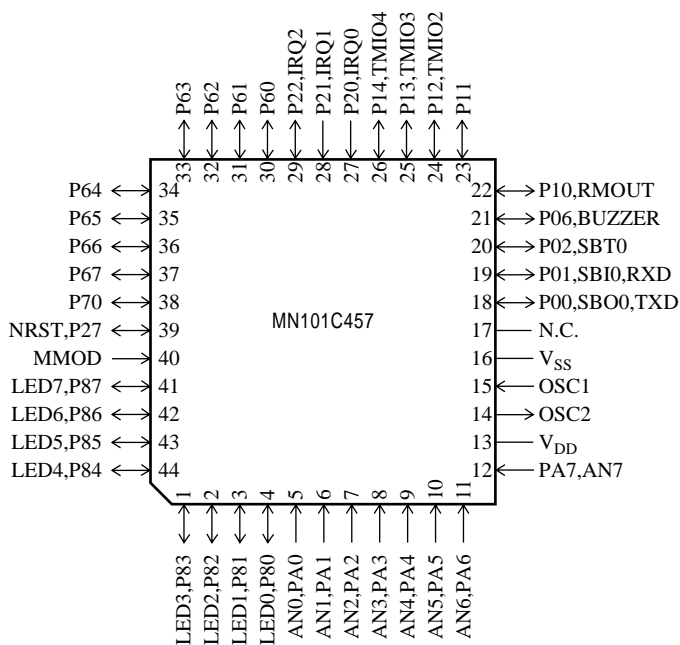

QFP044-P-1010E *Lead-free

Support Tool

In-circuit Emulator	PX-ICE101C/D+PX-PRB101C42-QFP044-P-1010		
EPROM Built-in Type	Type	MN101CP457BF	
	ROM (× 8-bit)	16 K	
	RAM (× 8-bit)	0.5 K	
	Minimum instruction execution time	0.10 μs (at 4.5 V to 5.5 V, 20 MHz)	
		0.238 μs (at 2.7 V to 5.5 V, 8.39 MHz)	
Package	QFP044-P-1010E *Lead-free		

Request for your special attention and precautions in using the technical information and semiconductors described in this material

- (1) An export permit needs to be obtained from the competent authorities of the Japanese Government if any of the products or technologies described in this material and controlled under the "Foreign Exchange and Foreign Trade Law" is to be exported or taken out of Japan.
- (2) The technical information described in this material is limited to showing representative characteristics and applied circuits examples of the products. It neither warrants non-infringement of intellectual property right or any other rights owned by our company or a third party, nor grants any license.
- (3) We are not liable for the infringement of rights owned by a third party arising out of the use of the product or technologies as described in this material.
- (4) The products described in this material are intended to be used for standard applications or general electronic equipment (such as office equipment, communications equipment, measuring instruments and household appliances).
Consult our sales staff in advance for information on the following applications:
 - Special applications (such as for airplanes, aerospace, automobiles, traffic control equipment, combustion equipment, life support systems and safety devices) in which exceptional quality and reliability are required, or if the failure or malfunction of the products may directly jeopardize life or harm the human body.
 - Any applications other than the standard applications intended.
- (5) The products and product specifications described in this material are subject to change without notice for modification and/or improvement. At the final stage of your design, purchasing, or use of the products, therefore, ask for the most up-to-date Product Standards in advance to make sure that the latest specifications satisfy your requirements.
- (6) When designing your equipment, comply with the guaranteed values, in particular those of maximum rating, the range of operating power supply voltage, and heat radiation characteristics. Otherwise, we will not be liable for any defect which may arise later in your equipment.
Even when the products are used within the guaranteed values, take into the consideration of incidence of break down and failure mode, possible to occur to semiconductor products. Measures on the systems such as redundant design, arresting the spread of fire or preventing glitch are recommended in order to prevent physical injury, fire, social damages, for example, by using the products.
- (7) When using products for which damp-proof packing is required, observe the conditions (including shelf life and amount of time let standing of unsealed items) agreed upon when specification sheets are individually exchanged.
- (8) This material may be not reprinted or reproduced whether wholly or partially, without the prior written permission of Matsushita Electric Industrial Co., Ltd.