

# TA8106F

## STEREO HEADPHONE POWER AMPLIFIER (1.5V USE)

The TA8106F is a Dual headphone amplifier IC designed for low voltage operation (1.5V, 3.0V), which is suitable for stereo headphone radio and radio cassette recorder equipments. This item can realize the low power dissipation and have high power output capability.

### FEATURES

- Condenser-less for input and output.
- Condenser-less for bootstrap.
- Built-in the muting function.
- High power output capability according to adopting the Matrix Drive Method.

$$\begin{cases} P_o(1) = 14\text{mW/ch (Typ.) at } V_{in(R)} = V_{in(L)} \text{ mode} \\ P_o(2) = 5.5\text{mW/ch (Typ.) at } V_{in(R)} = -V_{in(L)} \text{ mode} \\ P_o(3) = 10.5\text{mW/ch (Typ.) at } V_{in(R)} = 0 \text{ or } V_{in(L)} = 0 \\ (V_{CC} = 1.5\text{V}, R_L = 32\Omega, f = 1\text{kHz}, \text{THD} = 10\%) \end{cases}$$

- Operating supply voltage range. :  $V_{CC(opr)} = 0.9 \sim 5.0\text{V}$  ( $T_a = 25^\circ\text{C}$ )

### BLOCK DIAGRAM

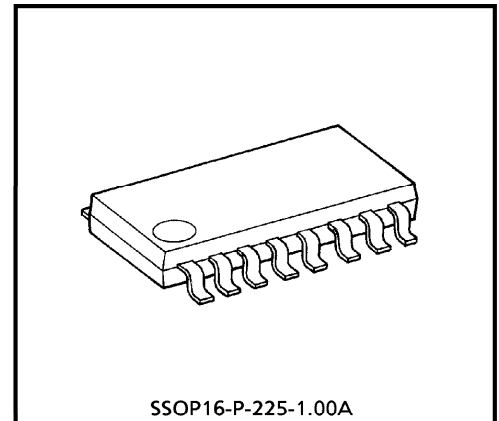
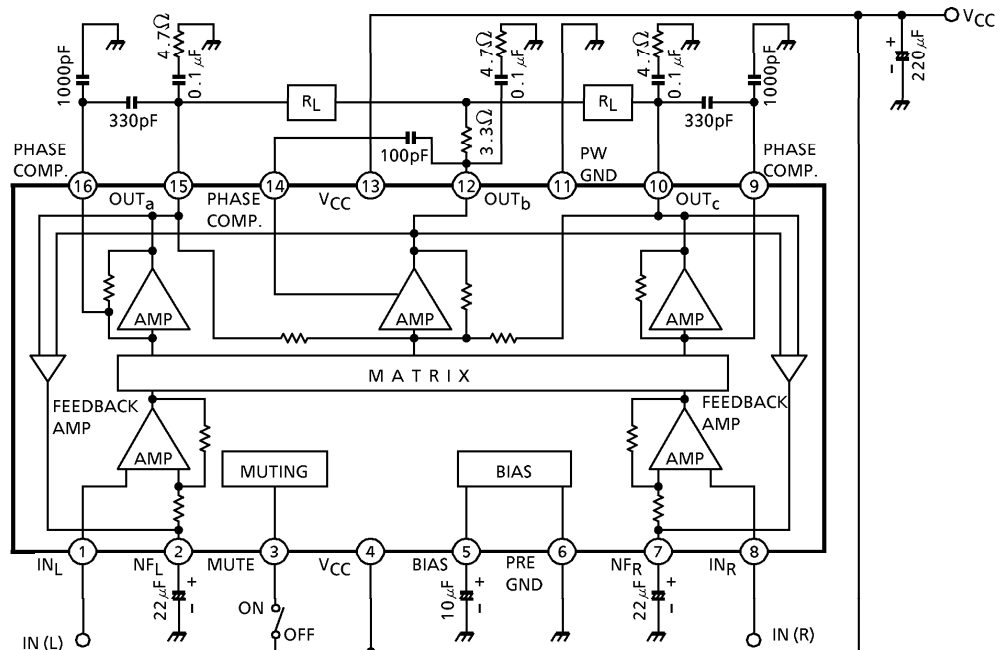

Weight : 0.14g (Typ.)

**SUMMARY OF MATRIX DRIVE METHOD**

Though the BTL is usually used to obtain enough power at low voltage, it can not be used for the headphone amplifier (especially, 1.5V USE), which has only one left-and right common line. Then a new modified BTL drive method is developed, which is called "Matrix Drive Method". It has only one common line.

Fig.1 Shows the Principle. The input signals of the audio frequency are applied to the terminal of L/R. These are transformed by the matrix converter into the outputs, as following ;

$$\begin{cases} V_{(a)} = L - \alpha R \\ V_{(b)} = -\alpha (L + R) \\ V_{(c)} = R - \alpha L \end{cases} \begin{cases} L, R : \text{input signal} \\ \alpha : \text{matrix ratio} \end{cases}$$

And the output signals of L/R loads are given by

$$\begin{cases} V_L = V_{(a)} - V_{(b)} = (1 + \alpha) L \\ V_R = V_{(c)} - V_{(b)} = (1 + \alpha) R \end{cases}$$

Thus, each output signal does not leak to another channel load.

This gain is  $(1 + \alpha)$  times as high as a conventional single amplifiers'. However the undistorted maximum output is determined by each clipping point of lines, (a), (b) and (c). Therefore, the most effective point is determined by the following states of input. As the state of input is at  $L = R$  mode,  $\alpha$  is  $1/3$ , so this system is operated most effectively. At  $L = -R$  mode,  $\alpha$  is whatever. And at single input mode (L or R only),  $\alpha$  is 1.

It is a common saying that the practical musical source consists of the common phase component in most. And the low frequency of that causes the clipping to product mostly. Therefore in this item,  $\alpha$  is  $1/3$ .

In result at  $L = R$  mode, this gain is obtained twice as high as a single amplifiers.

At single input mode,  $4/3$  times, at  $L = -R$  mode, is obtained as same as a single.

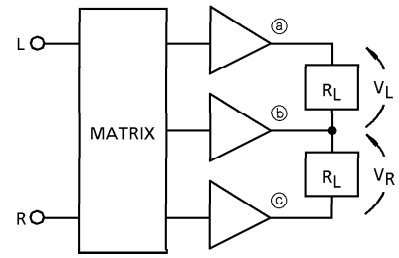

Fig.1

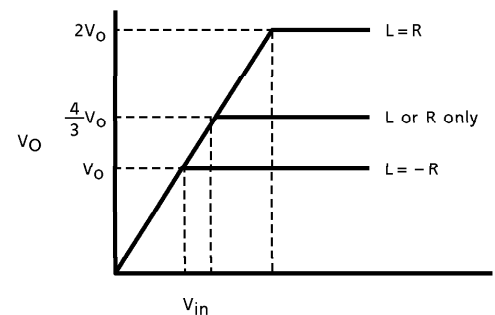

Fig.2

**APPLICATION NOTE**

(1) Input stage

The first stage is composed of the differential amplifier of PNP-input. Therefore, it is not necessary to use any coupling condensers (Fig.3).

The input impedance is determined by the internal resistance ( $51k\Omega$ ).

This output is connected to the next stage through the emitter follower.

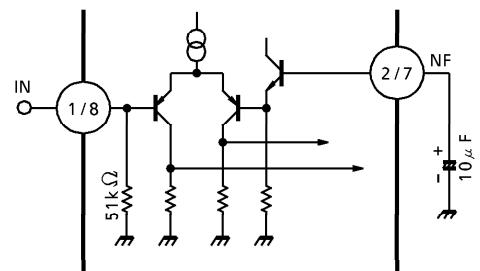

Fig.3

(2) Matrix converter

The matrix ratio is determined by the amplifier A<sub>1</sub>, A<sub>2</sub>, as shown in Fig.4. Each of the output currents, which have a ratio (1 : α), is formed by A<sub>1</sub>, A<sub>2</sub>.

The outputs of matrix converter, which are previously mentioned, are

$$\begin{cases} V_{\text{a}} = L - \alpha R \\ V_{\text{b}} = -\alpha (L + R) \\ V_{\text{c}} = R - \alpha L \end{cases}$$

These are applied to the drivers B<sub>1</sub>, C, B<sub>2</sub>.

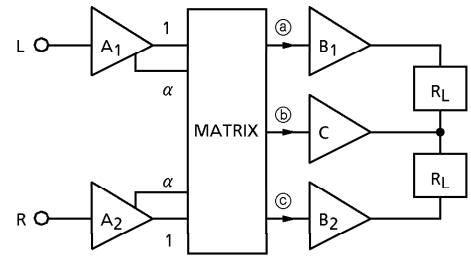

Fig.4

(3) Muting function

As the terminal pin ③ for the muting function is connected to V<sub>CC</sub>, Q<sub>1</sub> is turned on, then Q<sub>2</sub> and Q<sub>3</sub> are turned on. Therefore the DC voltage of the terminal pin ⑤ is down, and all of the circuits stop. At this time, the quiescent supply current (I<sub>CCQ</sub>) scarcely flows into this system. As the terminal pin ③ is opened, the DC voltage of the terminal pin ⑤ does not quickly come up, because of the presence of the CR time-constant. So, the shock-noise is reduced. As the supply voltage is turned on, this operation is also done.

(4) DC Feed-Back circuit

In this system, the output loads are directly connected to the output terminals. Therefore, in order that the output DC offset voltages are reduced, this system is built-in the DC feed-back circuit. The currents, which are in proportion of the differential voltage between two DC terminal voltages in each

$$\begin{aligned} I_1 &= K (V_{\text{a}} - V_{\text{b}}) \\ I_2 &= K (V_{\text{c}} - V_{\text{b}}) \end{aligned}$$

are fed into the matrix converter.

Thus the DC offset voltages are reduced. This system is effective more than about 1.2V.

(5) Oscillation precaution

Small temperature coefficient and excellent frequency characteristic is needed by capacitors below.

- Oscillation preventing capacitors for power amplifier output.
- Capacitor between V<sub>CC</sub> and GND

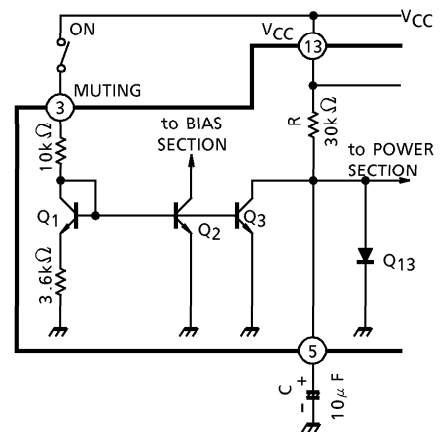

Fig.5

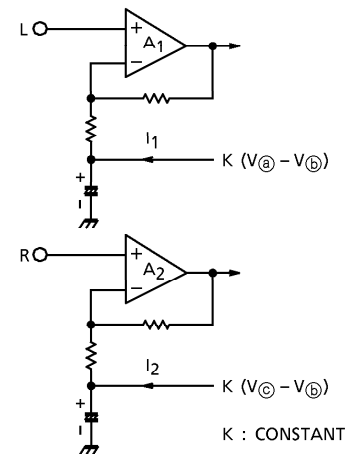

Fig.6

(6) Total gain :  $G_V$

In this system, the total gain  $G_V$  is given by

$$G_V = 20 \log \frac{4 \times R_2}{R_1}$$

Typical values of this system is  $R_1 = 1.6k\Omega$ ,  $R_2 = 19k\Omega$ , then this gain is ;

$$G_V \doteq 34\text{dB (Typ.)}$$

(Note) The internal resistances are fixed, then the gain is fixed. In addition to the attenuator in front of this system, the gain is changeable.

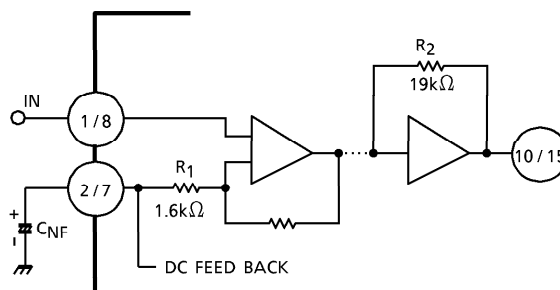

Fig.7

**MAXIMUM RATINGS** ( $T_a = 25^\circ\text{C}$ )

CHARACTERISTIC	SYMBOL	RATING	UNIT
Supply Voltage	$V_{CC}$	5	V
Output Current	$I_O$ (peak)	160	mA
Power Dissipation	$P_D$ (Note)	350	mW
Operating Temperature	$T_{opr}$	-25~75	$^\circ\text{C}$
Storage Temperature	$T_{stg}$	-55~150	$^\circ\text{C}$

(Note) Derated above  $T_a = 25^\circ\text{C}$  in the proportion of  $2.8\text{mW}/^\circ\text{C}$ .

**ELECTRICAL CHARACTERISTICS (AC)**

(Unless otherwise specified,  $T_a = 25^\circ\text{C}$ ,  $V_{CC} = 1.5\text{V}$ ,  $f = 1\text{kHz}$ ,  $R_g = 620\Omega$ ,  $R_L = 32\Omega$ )

CHARACTERISTIC	SYMBOL	TEST CIRCUIT	TEST CONDITION	MIN.	TYP.	MAX.	UNIT
Quiescent Supply Current	$I_{CCQ}$	—	$V_{in} = 0$	—	6	8.4	mA
Input Resistance	$R_{IN}$	—		—	50	—	$k\Omega$
Voltage Gain	$G_V$	—	$V_{in} = -50\text{dBV}$	30	33	36	dB
Channel Balance	$\Delta G_V$	—	$V_{in(R)} = V_{in(L)}$	—	0	1.3	dB
Output Power	$P_o(1)$	—	$V_{in(R)} = V_{in(L)}$ THD = 10%	11	14	—	mW
	$P_o(2)$	—	$V_{in(R)} = -V_{in(L)}$ THD = 10%	—	5.5	—	
	$P_o(3)$	—	$V_{in(R)} = 0$ or $V_{in(L)} = 0$ THD = 10%	—	10.5	—	
Total Harmonic Distortion	THD (1)	—	$P_o(L) = P_o(R) = 1\text{mW}$ $V_{in(R)} = V_{in(L)}$	—	0.4	1.0	%
	THD (2)	—	$P_o(L) = P_o(R) = 1\text{mW}$ $V_{in(R)} = -V_{in(L)}$	—	2.5	—	
	THD (3)	—	$V_{in(R)} = 0$ or $V_{in(L)} = 0$ $P_o = 1\text{mW}$	—	0.9	—	
Output Noise	$V_{no}$	—	$R_g = 620\Omega$ , BPF = 20Hz~20kHz	—	0.15	0.3	$\text{mV}_{\text{rms}}$
Cross Talk	CT	—	$V_o = -10\text{dBV}$ , $R_g = 620\Omega$	—	32	—	dB
Ripple Rejection Ratio	RR	—	$V_r = -30\text{dBV}$ $f_r = 100\text{Hz}$ , $R_g = 620\Omega$	—	35	—	dB
Muting Attenuation	ATT	—	$V_{\text{MUTE}} = 1.5\text{V}$	—	60	—	dB

**DC CHARACTERISTICS** ( $V_{CC} = 1.5V$ ,  $T_a = 25^\circ C$ , terminal voltage at no signal)

PIN No.	SYMBOL	TYP.	UNIT
PIN ① (INPUT L)	$V_1$	0.16	V
PIN ② (NF L)	$V_2$	0.73	V
PIN ③ (MUTE)	$V_3$	—	V
PIN ④ ( $V_{CC}$ )	$V_4$	1.50	V
PIN ⑤ (BIAS)	$V_5$	0.74	V
PIN ⑥ (PRE GND)	$V_6$	0	V
PIN ⑦ (NF R)	$V_7$	0.73	V
PIN ⑧ (INPUT R)	$V_8$	0.16	V
PIN ⑨ (PHASE COMPENSATION)	$V_9$	0.80	V
PIN ⑩ (OUTPUT)	$V_{10}$	0.75	V
PIN ⑪ (PW GND)	$V_{11}$	0	V
PIN ⑫ (OUTPUT)	$V_{12}$	0.75	V
PIN ⑬ ( $V_{CC}$ )	$V_{13}$	1.50	V
PIN ⑭ (PHASE COMPENSATION)	$V_{14}$	0.80	V
PIN ⑮ (OUTPUT)	$V_{15}$	0.75	V
PIN ⑯ (PHASE COMPENSATION)	$V_{16}$	0.80	V

**TEST CIRCUIT**

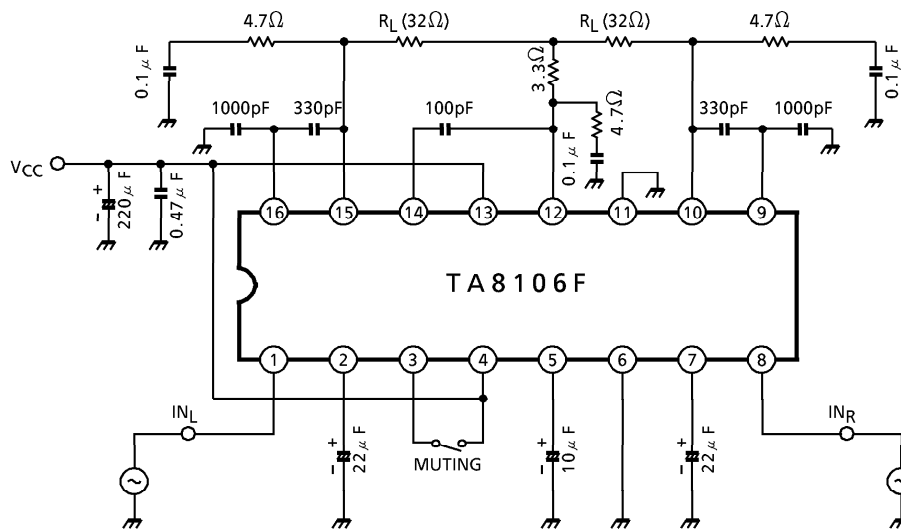

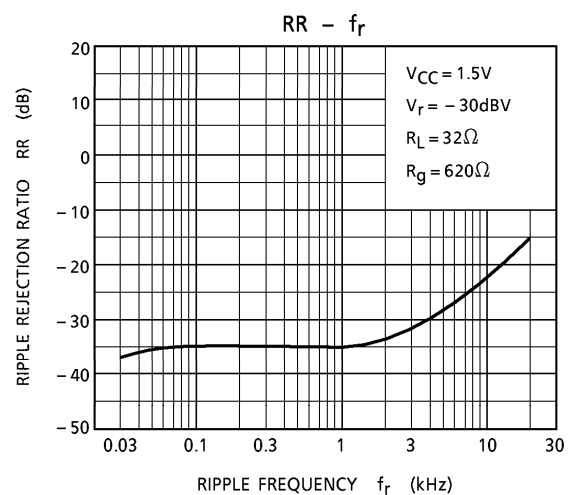
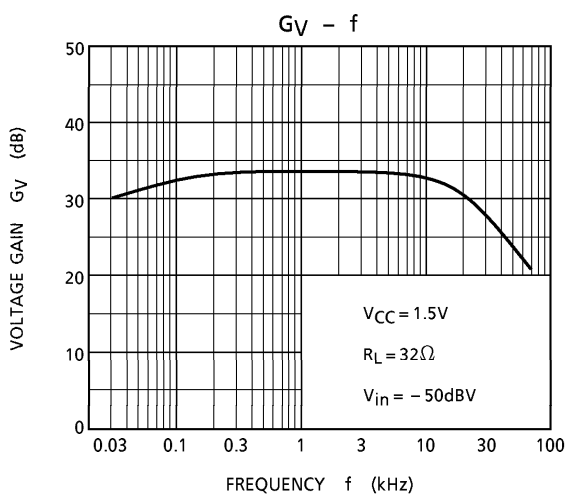
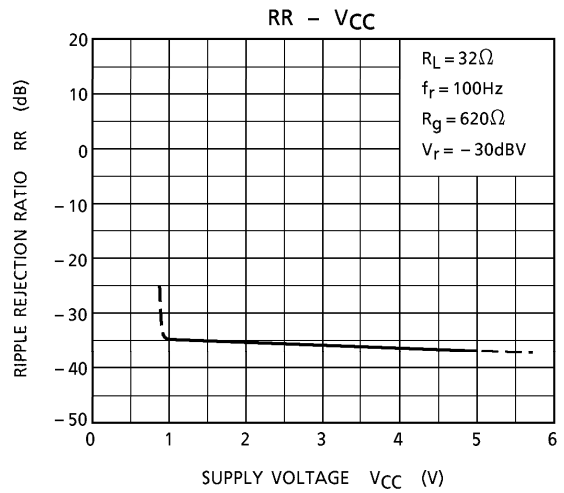
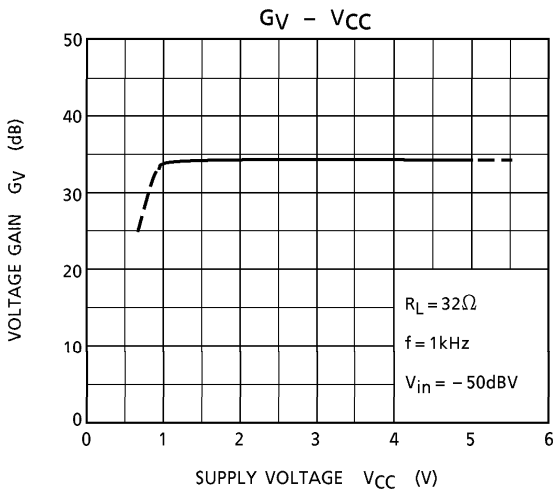
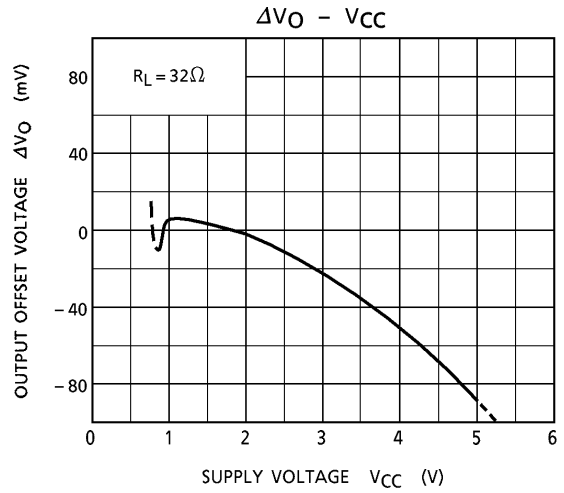
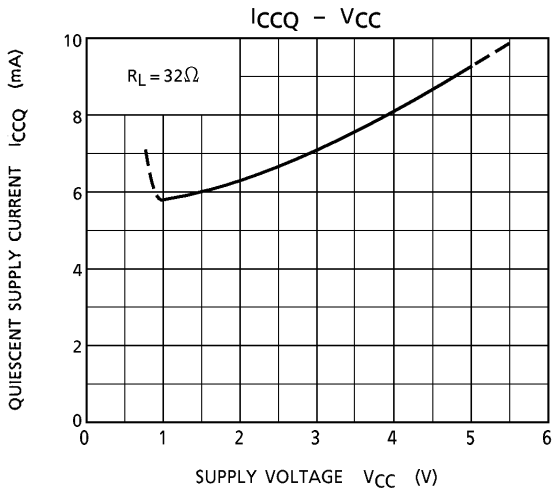

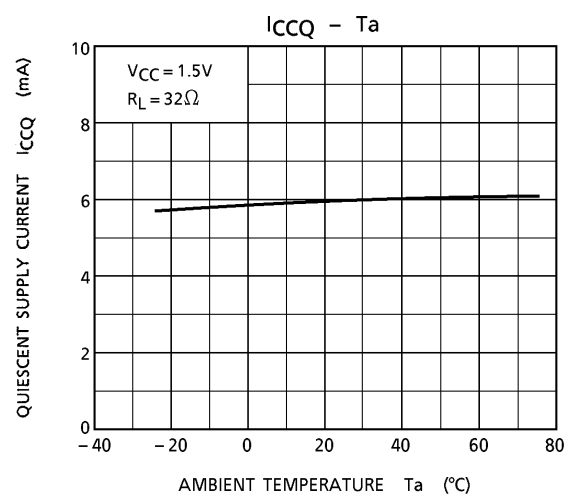
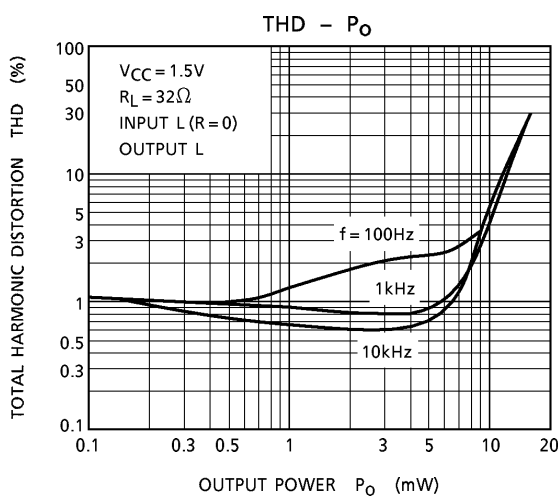
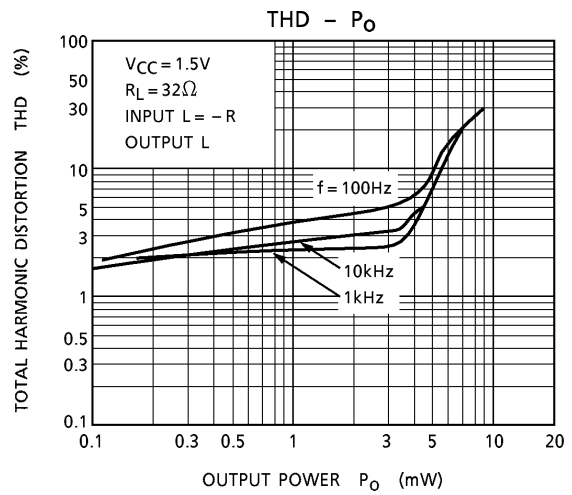
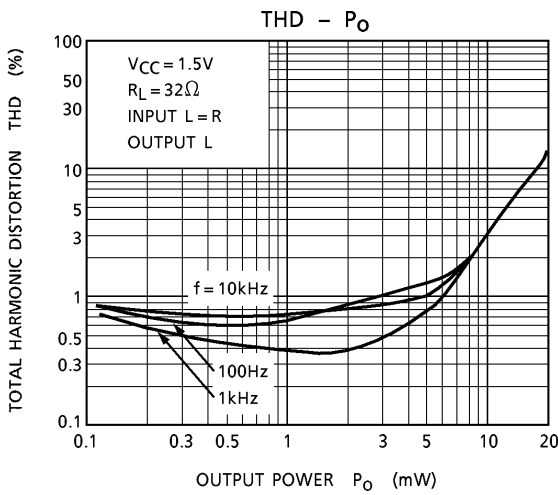
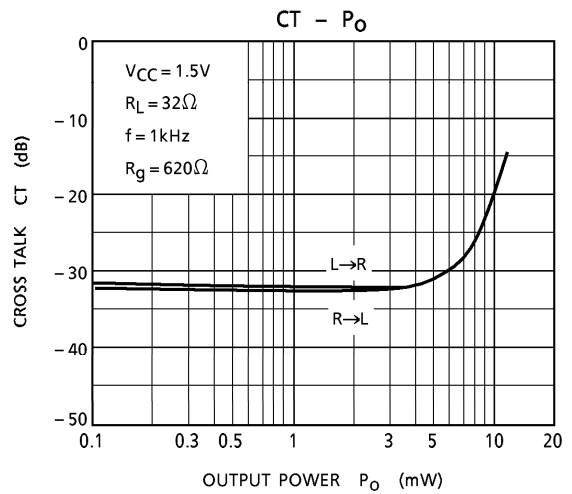
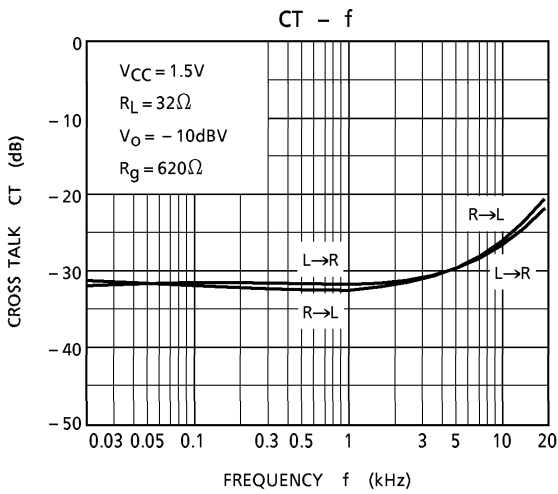

PACKAGE DIMENSIONS  
SSOP16-P-225-1.00A

Unit : mm

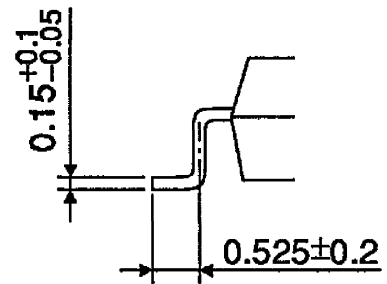
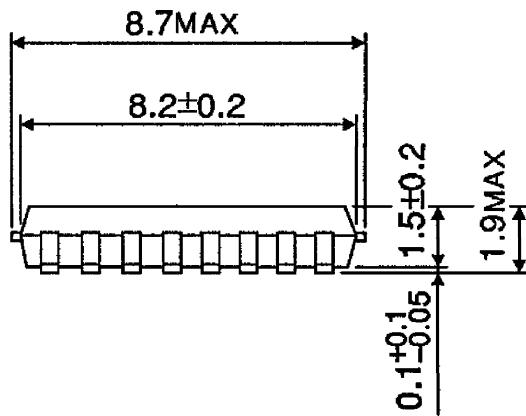
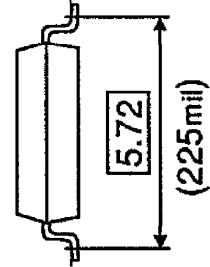
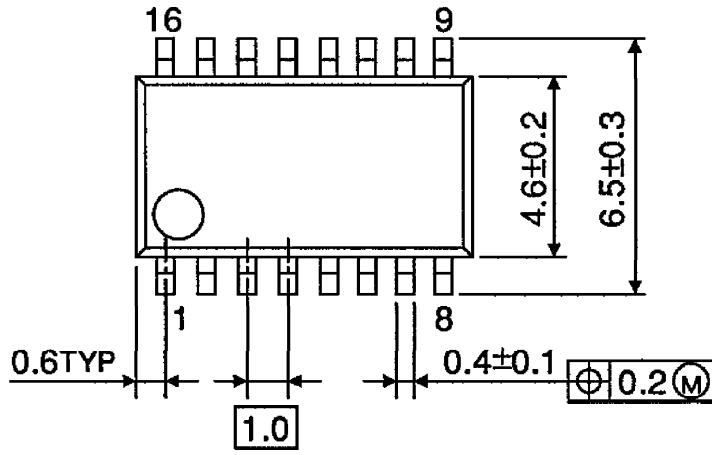

Weight : 0.14g (Typ.)



**RESTRICTIONS ON PRODUCT USE**

000707EBA

- TOSHIBA is continually working to improve the quality and reliability of its products. Nevertheless, semiconductor devices in general can malfunction or fail due to their inherent electrical sensitivity and vulnerability to physical stress. It is the responsibility of the buyer, when utilizing TOSHIBA products, to comply with the standards of safety in making a safe design for the entire system, and to avoid situations in which a malfunction or failure of such TOSHIBA products could cause loss of human life, bodily injury or damage to property. In developing your designs, please ensure that TOSHIBA products are used within specified operating ranges as set forth in the most recent TOSHIBA products specifications. Also, please keep in mind the precautions and conditions set forth in the "Handling Guide for Semiconductor Devices," or "TOSHIBA Semiconductor Reliability Handbook" etc..
- The TOSHIBA products listed in this document are intended for usage in general electronics applications (computer, personal equipment, office equipment, measuring equipment, industrial robotics, domestic appliances, etc.). These TOSHIBA products are neither intended nor warranted for usage in equipment that requires extraordinarily high quality and/or reliability or a malfunction or failure of which may cause loss of human life or bodily injury ("Unintended Usage"). Unintended Usage include atomic energy control instruments, airplane or spaceship instruments, transportation instruments, traffic signal instruments, combustion control instruments, medical instruments, all types of safety devices, etc.. Unintended Usage of TOSHIBA products listed in this document shall be made at the customer's own risk.
- The products described in this document are subject to the foreign exchange and foreign trade laws.
- The information contained herein is presented only as a guide for the applications of our products. No responsibility is assumed by TOSHIBA CORPORATION for any infringements of intellectual property or other rights of the third parties which may result from its use. No license is granted by implication or otherwise under any intellectual property or other rights of TOSHIBA CORPORATION or others.
- The information contained herein is subject to change without notice.