

TC74HC423AP, TC74HC423AF

DUAL RETRIGGERABLE MONOSTABLE MULTIVIBRATOR

The TC74HC423A is a high speed CMOS MONOSTABLE MULTIVIBRATOR fabricated with silicon gate C²MOS technology.

It achieves the high speed operation similar to equivalent LSTTL while maintaining the CMOS low power dissipation. There are two trigger inputs, \overline{A} input (Negative edge), and B input (Positive edge). These inputs are valid for a slow rise/fall time signal ($t_r=t_f=1\text{sec.}$) as they are schmitt trigger inputs.

After triggering, the output stays in a MONOSTABLE state for a time period determined by the external resistor and capacitor (R_x, C_x). A low level at the \overline{CLR} input breaks this state. In the MONOSTABLE state, if a new trigger is applied, it extends the MONOSTABLE period (retrigger mode).

Limitations for C_x and R_x are :

- External capacitor, C_x No limit
- External resistor, R_x $V_{CC}=2.0V$ more than $5k\Omega$
 $V_{CC}\geq 3.0V$ more than $1k\Omega$

All inputs are equipped with protection circuits against static discharge or transient excess voltage.

FEATURES :

- High Speed..... $t_{pd} = 25\text{ns}$ (typ.) at $V_{CC} = 5V$
- Low Power Dissipation
 - Standby State $I_{CC} = 4\mu\text{A}$ (Max.) at $T_a = 25^\circ\text{C}$
 - Active State $I_{CC} = 700\mu\text{A}$ (Max.) at $V_{CC} = 5V$
- High Noise Immunity..... $V_{NIH} = V_{NIL} = 28\% V_{CC}$ (Min.)
- Output Drive Capability 10 LSTTL Loads
- Symmetrical Output Impedance... $|I_{OH}| = I_{OL} = 4\text{mA}$ (Min.)
- Balanced Propagation Delays..... $t_{pLH} \approx t_{pHL}$
- Wide Operating Voltage Range... V_{CC} (opr.) = $2V \sim 6V$
- Pin and Function Compatible with 74LS 423

Note : In the case of using only one circuit, \overline{CLR} should be tied to GND, $R_x/C_x \cdot C_x \cdot Q \cdot \overline{Q}$ should be tied to OPEN, the other inputs should be tied to V_{CC} or GND.

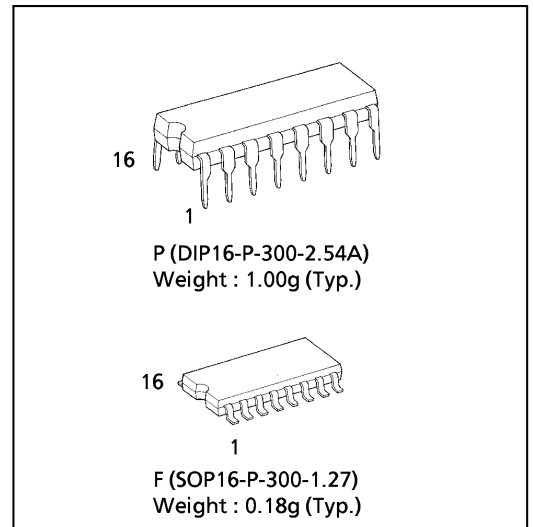

PIN ASSIGNMENT

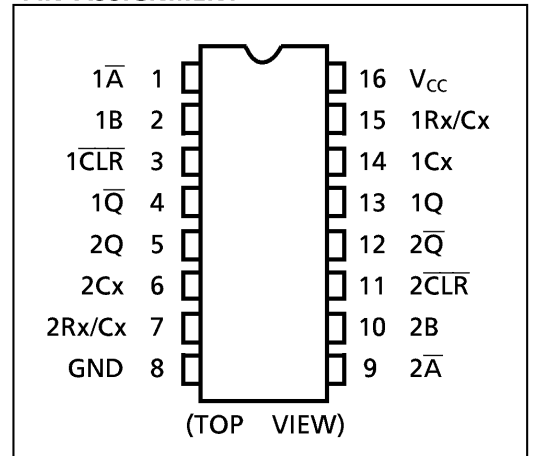

IEC LOGIC SYMBOL

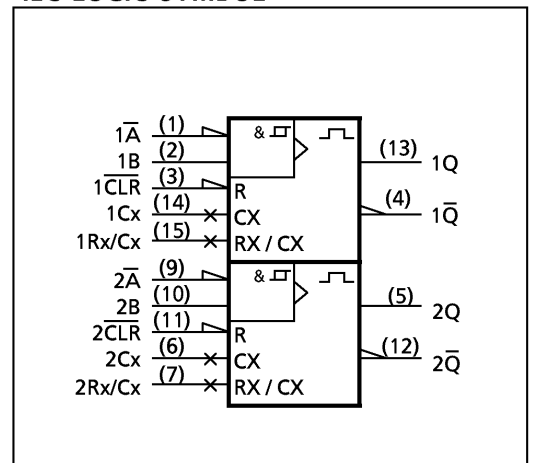

TRUTH TABLE

INPUTS			OUTPUTS		NOTE
\bar{A}	B	\bar{CLR}	Q	\bar{Q}	
	H	H			OUTPUT ENABLE
X	L	H	L	H	INHIBIT
H	X	H	L	H	INHIBIT
L		H			OUTPUT ENABLE
X	X	L	L	H	RESET

X : Don't Care

BLOCK DIAGRAM

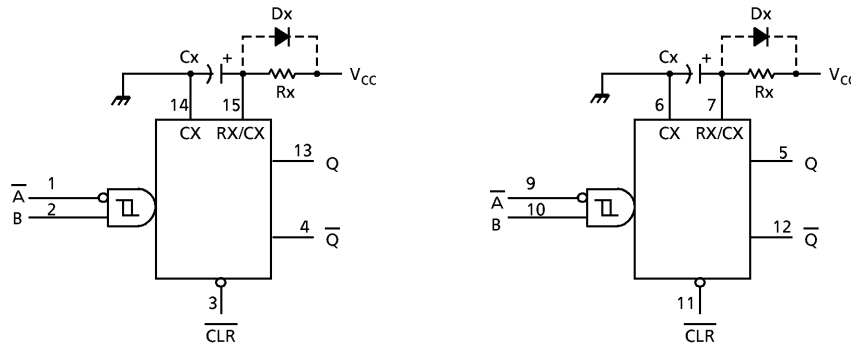

Notes: (1) Cx, Rx, Dx are external.
Capacitor, Resistor, and Diode, respectively.

(2) External clamping diode, Dx ;

The external capacitor is charged to V_{CC} level in the wait state, i.e. when no trigger is applied.

If the supply voltage is turned off, Cx is discharges mainly through the internal (parasitic) diode. If Cx is sufficiently large and V_{CC} drops rapidly, there will be some possibility of damaging the IC through in rush current or latch-up. If the capacitance of the supply voltage filter is large enough and V_{CC} drops slowly, the in rush current is automatically limited and damage to the IC is avoided.

The maximum value of forward current through the parasitic diode is $\pm 20\text{mA}$.

In the case of a large Cx, the limit of fall time of the supply voltage is determined as follows:

$$t_f \geq (V_{CC} - 0.7) C_x / 20\text{mA}$$

(t_f is the time between the supply voltage turn off and the supply voltage reaching $0.4 V_{CC}$.)

In the event a system does not satisfy the above condition, an external clamping diode (Dx) is needed to protect the IC from in rush current.

SYSTEM DIAGRAM

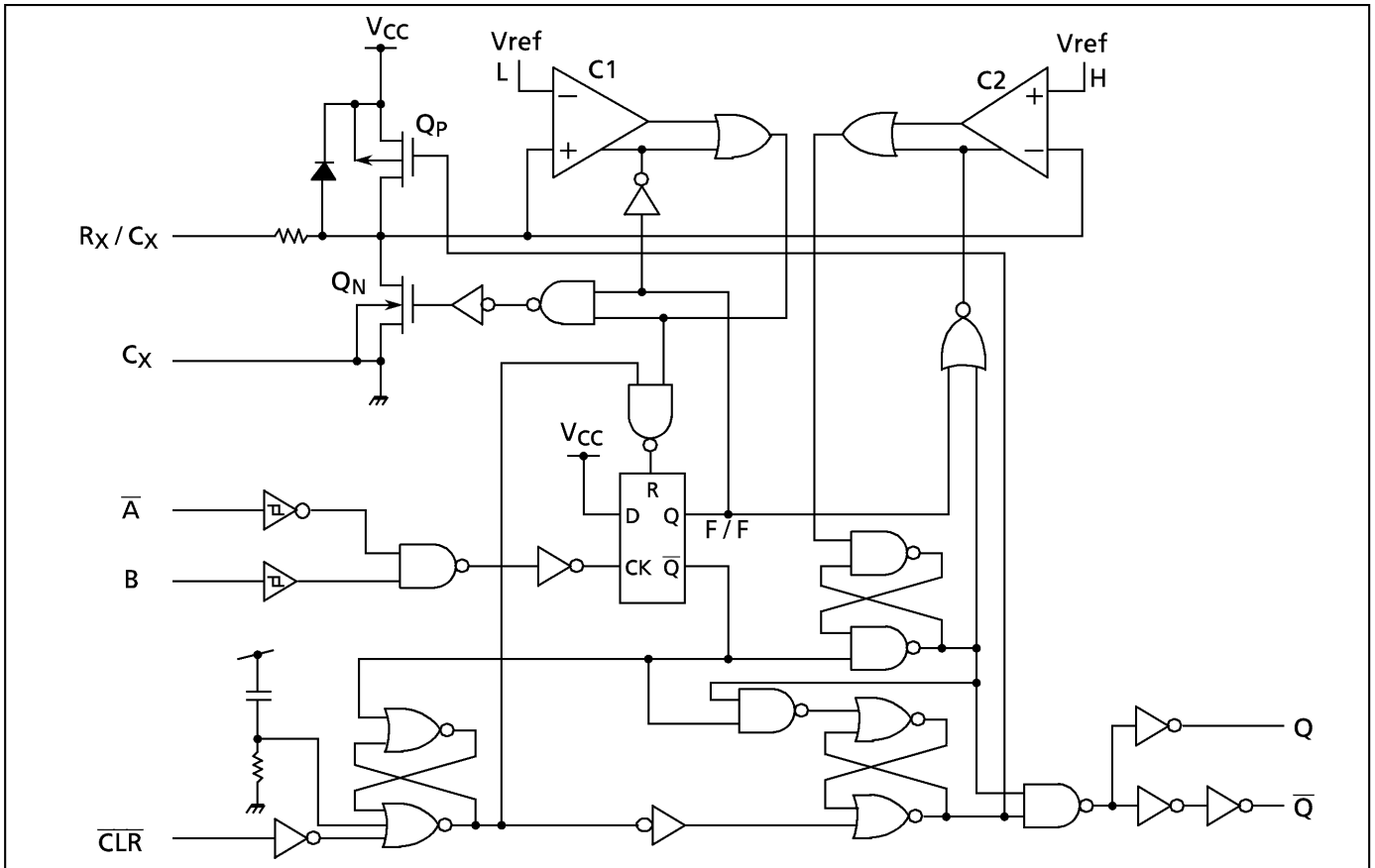

TIMING CHART

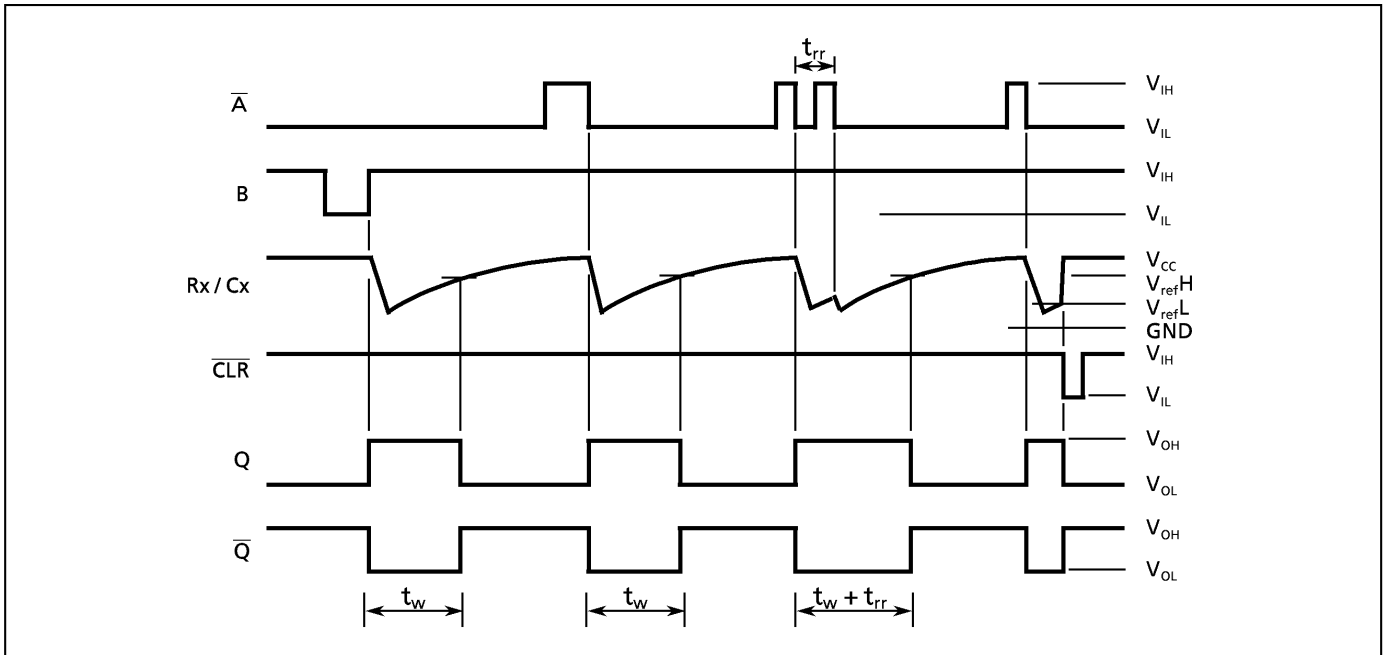

FUNCTIONAL DESCRIPTION

(1)Stand-by State

The external capacitor C_x is fully charged to V_{CC} in the stand-by state. That means, before triggering, the Q_P and Q_N transistors which are connected to the R_x/C_x node are in the off state. Two comparators that relate to the timing of the output pulse, and two reference voltage supplies turn off. The total supply current is only leakage current.

(2)trigger operation

Trigger operation is effective in either of the following two cases. First, the condition where the \overline{A} input is low, and the B input has a rising signal; second, where the B input is high, and the \overline{A} input has a falling signal.

After a trigger becomes effective, comparators C1 and C2 start operating, and Q_N is turned on. The external capacitor discharges through Q_N . The voltage level of the R_x/C_x node drops. If the R_x/C_x voltage level falls to the internal reference voltage V_{refL} , the output of C1 becomes low. The flip-flop is then reset and Q_N turns off. At that moment C1 stops but C2 continues operating.

After Q_N turns off, the voltage at the R_x/C_x starts rising at a rate determined by the time constant of external capacitor C_x and resistor R_x .

Upon the triggering, output Q becomes high, following some delay time of the internal F/F and gates. It stays high even if the voltage of R_x/C_x changes from falling to rising. When R_x/C_x reaches the internal reference voltage V_{refH} , the output of C2 becomes low, the output Q goes low and C2 stops its operation. That means, after triggering, when the voltage level of the R_x/C_x reaches V_{refH} , the IC returns to its MONOSTABLE state.

With large values of C_x and R_x , and ignoring the discharge time of the capacitor and internal delays of the IC, the width of the output pulse, t_w (OUT), is as follows:

$$t_w(\text{OUT}) = 1.0 \cdot C_x \cdot R_x$$

(3)Retrigger operation

When a new trigger is applied to input \overline{A} or B while in the MONOSTABLE state, it is effective only if the IC is charging C_x . The voltage level of the R_x/C_x node then falls to V_{refL} level again. Therefore the Q output stays high if the next trigger comes in before the time period set by C_x and R_x .

If the 2nd trigger is very close to previous trigger, such as an occurrence during the discharge cycle, it will have no effect.

The minimum time for a trigger to be effective 2nd trigger, t_{tr} (Min.), depends on V_{CC} and C_x .

(4)Reset operation

In normal operation, \overline{CLR} input is held high. If \overline{CLR} is low, a trigger has no effect because the Q output is held low and the trigger control F/F is reset. Also, Q_P turns on and C_x is charged rapidly to V_{CC} .

This means if \overline{CLR} input is set low, the IC goes into a wait state.

ABSOLUTE MAXIMUM RATINGS

PARAMETER	SYMBOL	VALUE	UNIT
Supply Voltage Range	V_{CC}	-0.5~7	V
DC Input Voltage	V_{IN}	-0.5~ $V_{CC}+0.5$	V
DC Output Voltage	V_{OUT}	-0.5~ $V_{CC}+0.5$	V
Input Diode Current	I_{IK}	± 20	mA
Output Diode Current	I_{OK}	± 20	mA
DC Output Current	I_{OUT}	± 25	mA
DC V_{CC} /Ground Current	I_{CC}	± 50	mA
Power Dissipation	P_D	500 (DIP)* / 180 (SOP)	mW
Storage Temperature	T_{stg}	-65~150	°C

*500mW in the range of $T_a = -40^{\circ}\text{C} \sim 65^{\circ}\text{C}$. From $T_a = 65^{\circ}\text{C}$ to 85°C a derating factor of $-10\text{mW}/^{\circ}\text{C}$ shall be applied until 300mW.

RECOMMENDED OPERATING CONDITIONS

PARAMETER	SYMBOL	VALUE	UNIT
Supply Voltage	V_{CC}	2~6	V
Input Voltage	V_{IN}	0~ V_{CC}	V
Output Voltage	V_{OUT}	0~ V_{CC}	V
Operating Temperature	T_{opr}	-40~85	°C
Input Rise and Fall Time (CLR Only)	t_r, t_f	0~1000 ($V_{CC} = 2.0\text{V}$) 0~500 ($V_{CC} = 4.5\text{V}$) 0~400 ($V_{CC} = 6.0\text{V}$)	ns
External Capacitor	C_x	No Limitation *	F
External Resistor	R_x	$\geq 5\text{K}$ ($V_{CC} = 2.0\text{V}$) * $\geq 1\text{K}$ ($V_{CC} \geq 3.0\text{V}$) *	Ω

* The maximum allowable values of C_x and R_x are a function of leakage of capacitor C_x , the leakage of TC74HC423A, and leakage due to board layout and surface resistance.
Susceptibility to externally induced noise signals may occur for $R_x > 1\text{M}\Omega$.

DC ELECTRICAL CHARACTERISTICS

PARAMETER	SYMBOL	TEST CONDITION	V _{CC} (V)	Ta = 25°C			Ta = -40~85°C		UNIT	
				MIN.	TYP.	MAX.	MIN.	MAX.		
High - Level Input Voltage	V _{IH}		2.0 4.5 6.0	1.50 3.15 4.20	— — —	— — —	1.50 3.15 4.20	— — —	V	
Low - Level Input Voltage	V _{IL}		2.0 4.5 6.0	— — —	— — —	0.50 1.35 1.80	— — —	0.50 1.35 1.80	V	
High - Level Output Voltage (Q, \bar{Q})	V _{OH}	V _{IN} = V _{IH} or V _{IL}	I _{OH} = -20μA	2.0	1.9	2.0	—	1.9	—	V
				4.5	4.4	4.5	—	4.4	—	
			6.0	5.9	6.0	—	5.9	—		
			4.5	4.18	4.31	—	4.13	—		
			6.0	5.68	5.80	—	5.63	—		
Low - Level Output Voltage (Q, \bar{Q})	V _{OL}	V _{IN} = V _{IH} or V _{IL}	I _{OL} = 20μA	2.0	—	0.0	0.1	—	0.1	V
				4.5	—	0.0	0.1	—	0.1	
			6.0	—	0.0	0.1	—	0.1		
			4.5	—	0.17	0.26	—	0.33		
			6.0	—	0.18	0.26	—	0.33		
Input Leakage Current	I _{IN}	V _{IN} = V _{CC} or GND	6.0	—	—	± 0.1	—	± 1.0	μA	
Rx / Cx Terminal Off - State Current	I _{IN}	V _{IN} = V _{CC} or GND	6.0	—	—	± 0.1	—	± 1.0		
Quiescent Supply Current	I _{CC}	V _{IN} = V _{CC} or GND	6.0	—	—	4.0	—	40.0		
Active - State * Supply Current	I _{CC}	V _{IN} = V _{CC} or GND Rx / Cx = 0.5 V _{CC}	2.0	—	45	200	—	260	μA	
			4.5	—	400	500	—	650	μA	
			6.0	—	0.7	1.0	—	1.3	mA	

* : per circuit

TIMING REQUIREMENTS (Input t_r = t_f = 6ns)

PARAMETER	SYMBOL	TEST CONDITION	V _{CC} (V)	Ta = 25°C		Ta = -40~85°C	UNIT
				TYP.	LIMIT	LIMIT	
Minimum Pulse Width	t _{W(L)} t _{W(H)}		2.0	—	75	95	ns
			4.5	—	15	19	
			6.0	—	13	16	
Minimum Clear Pulse Width	t _{W(L)}		2.0	—	75	95	
			4.5	—	15	19	
			6.0	—	13	16	
Minimum Clear Removal Time	t _{rem}		2.0	—	5	5	
			4.5	—	5	5	
			6.0	—	5	5	
Minimum Retrigger Time	t _{rr}	Rx = 1KΩ Cx = 100pF	2.0	325	—	—	μs
			4.5	108	—	—	
			6.0	78	—	—	
		Rx = 1KΩ Cx = 0.01μF	2.0	5.0	—	—	
			4.5	1.4	—	—	
			6.0	1.2	—	—	

AC ELECTRICAL CHARACTERISTICS (C_L = 15pF, V_{CC} = 5V, Ta = 25°C, Input t_r = t_f = 6ns)

PARAMETER	SYMBOL	TEST CONDITION	MIN.	TYP.	MAX.	UNIT
Output Transition Time	t _{TLH} t _{THL}		—	4	8	ns
Propagation Delay Time (\overline{A} , B-Q, \overline{Q})	t _{pLH} t _{pHL}		—	25	36	
Propagation Delay Time (\overline{CL} -Q, \overline{Q})	t _{pLH} t _{pHL}		—	16	27	

AC ELECTRICAL CHARACTERISTICS (C_L = 50pF, Input t_r = t_f = 6ns)

PARAMETER	SYMBOL	TEST CONDITION	Ta = 25°C			Ta = -40-85°C		UNIT	
			V _{CC} (V)	MIN.	TYP.	MAX.	MIN.		MAX.
Output Transition Time	t _{TLH} t _{THL}		2.0	—	30	75	—	95	ns
			4.5	—	8	15	—	19	
			6.0	—	7	13	—	16	
Propagation Delay Time (\overline{A} , B-Q, \overline{Q})	t _{pLH} t _{pHL}		2.0	—	102	210	—	265	ns
			4.5	—	29	42	—	53	
			6.0	—	22	36	—	45	
Propagation Delay Time (\overline{CL} -Q, \overline{Q})	t _{pLH} t _{pHL}		2.0	—	68	160	—	200	ns
			4.5	—	20	32	—	40	
			6.0	—	16	27	—	34	
Output Pulse Width	tw _{OUT}	Cx = 28PF Rx = 6KΩ (V _{CC} = 2V)	2.0	—	700	2000	—	2500	ns
			4.5	—	250	400	—	500	
			6.0	—	210	340	—	425	
		Cx = 0.01μF Rx = 10KΩ	2.0	90	110	130	90	130	μs
			4.5	95	105	115	95	115	
			6.0	95	105	115	95	115	
		Cx = 0.1μF Rx = 10KΩ	2.0	0.9	1.0	1.2	0.9	1.2	ms
			4.5	0.9	1.0	1.1	0.9	1.1	
			6.0	0.9	1.0	1.1	0.9	1.1	
Output Pulse Width Error Between Circuits (In same Package)	Δtw _{OUT}		—	± 1	—	—	—	%	
Input Capacitance	C _{IN}		—	5	10	—	10	pF	
Power Dissipation Capacitance	C _{PD} (1)	Note (1)	—	162	—	—	—		

Note (1) C_{PD} is defined as the value of the internal equivalent capacitance which is calculated from the operating current consumption without load.

Average operating current can be obtained by the equation :

$$I_{CC}(\text{opr}) = C_{PD} \cdot V_{CC} \cdot f_{IN} + I_{CC}' \cdot \text{Duty} / 100 + I_{CC} / 2 \text{ (per circuit)}$$

(I_{CC}' : Active Supply Current)

(Duty : %)

OUTPUT PULSE WIDTH CONSTANT K- SUPPLY VOLTAGE (TYPICAL)

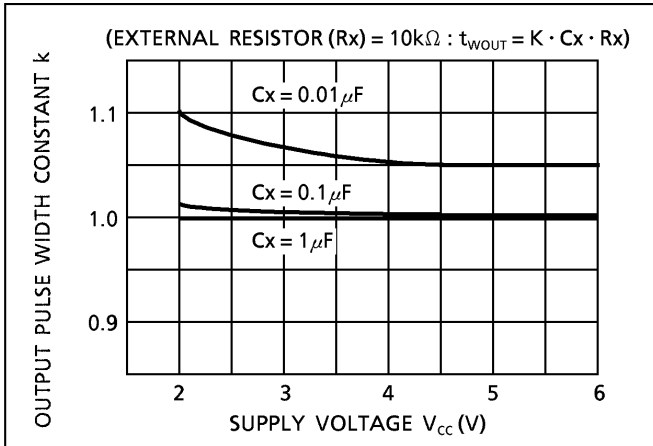

t_{wOUT} - C_x CHARACTERISTICS (TYP.)

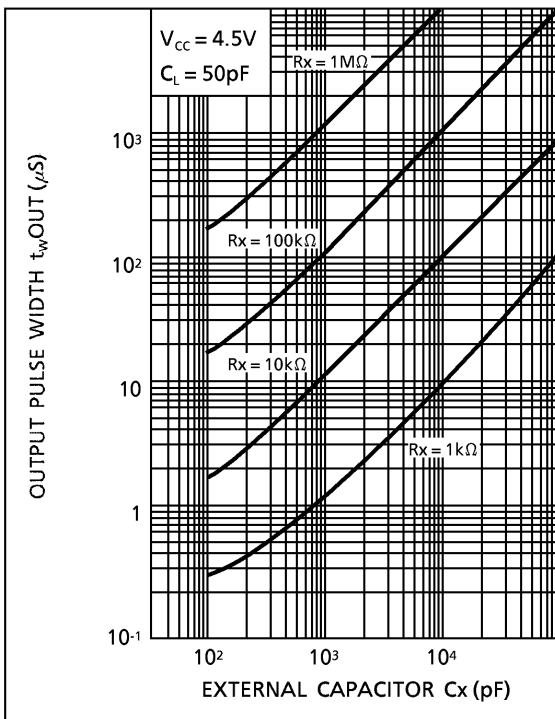

t_{rr} - V_{CC} CHARACTERISTICS (TYP.)

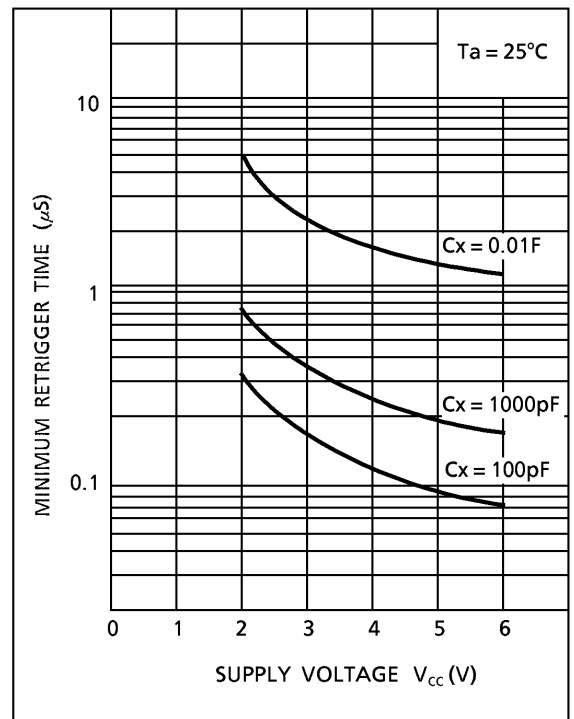

DIP 16PIN PACKAGE DIMENSIONS (DIP16-P-300-2.54A)

Unit in mm

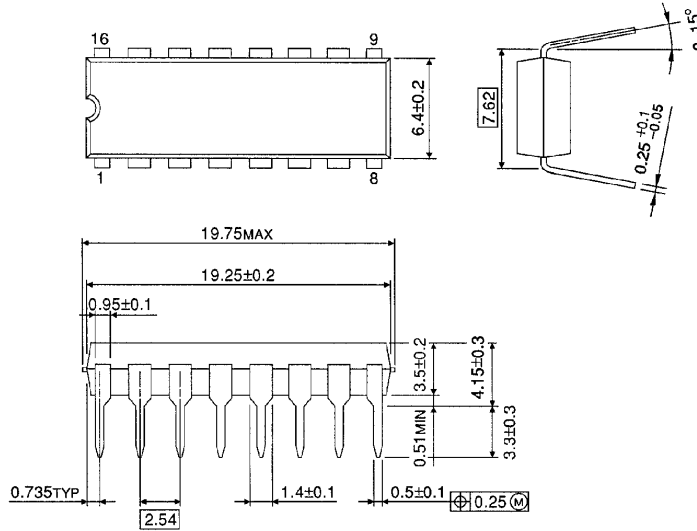

Weight : 1.00g (Typ.)

SOP 16PIN (200mil BODY) PACKAGE DIMENSIONS (SOP16-P-300-1.27)

Unit in mm

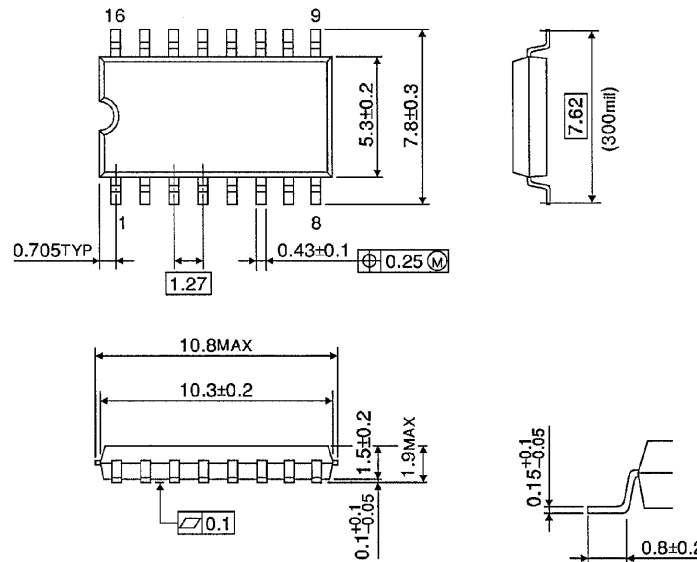

Weight : 0.18g (Typ.)

RESTRICTIONS ON PRODUCT USE

000707EBA

- TOSHIBA is continually working to improve the quality and reliability of its products. Nevertheless, semiconductor devices in general can malfunction or fail due to their inherent electrical sensitivity and vulnerability to physical stress. It is the responsibility of the buyer, when utilizing TOSHIBA products, to comply with the standards of safety in making a safe design for the entire system, and to avoid situations in which a malfunction or failure of such TOSHIBA products could cause loss of human life, bodily injury or damage to property. In developing your designs, please ensure that TOSHIBA products are used within specified operating ranges as set forth in the most recent TOSHIBA products specifications. Also, please keep in mind the precautions and conditions set forth in the "Handling Guide for Semiconductor Devices," or "TOSHIBA Semiconductor Reliability Handbook" etc..
- The TOSHIBA products listed in this document are intended for usage in general electronics applications (computer, personal equipment, office equipment, measuring equipment, industrial robotics, domestic appliances, etc.). These TOSHIBA products are neither intended nor warranted for usage in equipment that requires extraordinarily high quality and/or reliability or a malfunction or failure of which may cause loss of human life or bodily injury ("Unintended Usage"). Unintended Usage include atomic energy control instruments, airplane or spaceship instruments, transportation instruments, traffic signal instruments, combustion control instruments, medical instruments, all types of safety devices, etc.. Unintended Usage of TOSHIBA products listed in this document shall be made at the customer's own risk.
- The products described in this document are subject to the foreign exchange and foreign trade laws.
- The information contained herein is presented only as a guide for the applications of our products. No responsibility is assumed by TOSHIBA CORPORATION for any infringements of intellectual property or other rights of the third parties which may result from its use. No license is granted by implication or otherwise under any intellectual property or other rights of TOSHIBA CORPORATION or others.
- The information contained herein is subject to change without notice.