

## DUAL 5.1V REGULATOR WITH DISABLE AND RESET

ADVANCE DATA

- OUTPUT CURRENTS UP TO 1A
- FIXED PRECISION OUTPUT VOLTAGES 5.1V  $\pm 2\%$
- OUTPUT 1 WITH RESET FACILITY
- OUTPUT 2 WITH DISABLE BY TTL INPUT
- SHORT CIRCUIT PROTECTION AT BOTH OUTPUTS
- THERMAL PROTECTION
- LOW DROP OUTPUT VOLTAGE

### DESCRIPTION

The TDA8137 is a monolithic dual positive voltage regulator designed to provide fixed precision output voltages of 5.1V at currents up to 1A.

An internal reset circuit generates a delayed reset pulse when the output 1 decrease below the regulated voltage value.

Output 2 can be disabled by TTL input.

Short circuit and thermal protections are included.



### BLOCK DIAGRAM

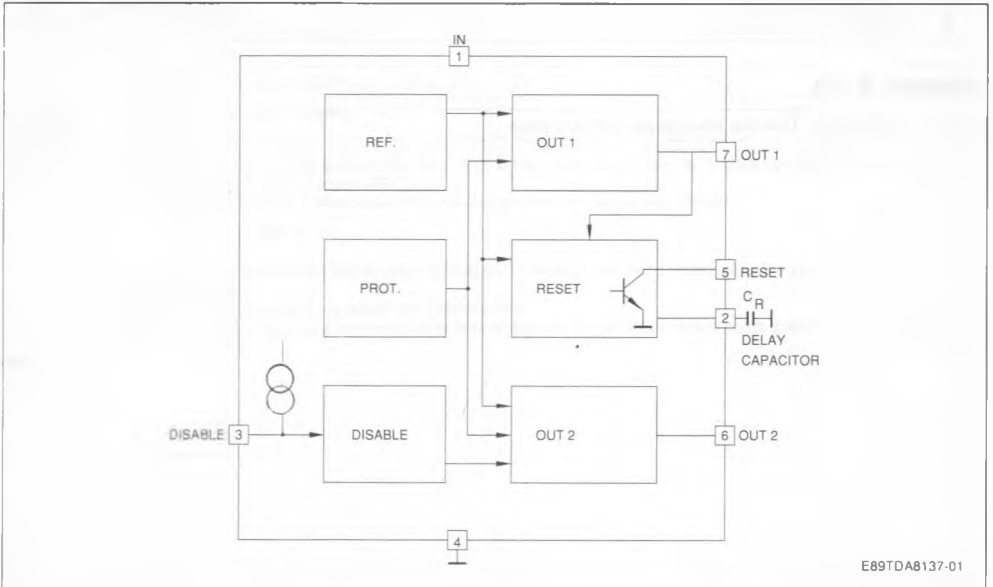

## PIN CONNECTION (top view)

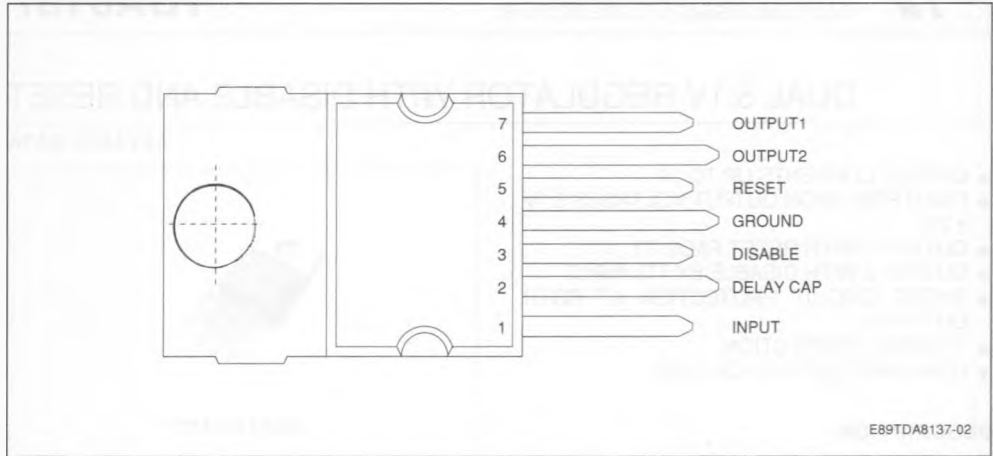

## ABSOLUTE MAXIMUM RATINGS

Symbol	Parameter	Value	Unit
$V_{IN}$	DC Input Voltage Pin 1	20	V
$V_{DIS}$	Disable Input Voltage Pin 3	20	V
$V_{RST}$	Output Voltage at Pin 5	20	V
$I_{O1,2}$	Output Currents	Internally Limited	
$P_t$	Power Dissipation	Internally Limited	
$T_{STG}$	Storage Temperature	- 65 to + 150	°C
$T_j$	Junction Temperature	0 to + 150	°C

## THERMAL DATA

$R_{TH(j-c)}$	Maximum Thermal Resistance Junction-case	3	°C/W
---------------	--	---	------

ELECTRICAL CHARACTERISTICS ( $V_{IN} = 7V$  ;  $T_J = 25^\circ C$  unless otherwise specified)

Symbol	Parameter	Test Conditions	Min.	Typ.	Max.	Unit
$V_{O1,2}$	Output Voltage	$I_{O1,2} = 10mA$	5	5.1	5.2	V
		$7V < V_{IN} < 14V$ $5mA < I_0 < 750mA$	4.9		5.3	V
$V_{I01,2}$	Dropout Voltage	$I_{O1,2} = 750mA$			1.4	V
		$I_{O1,2} = 1A$			2	V
$\Delta V_{O1,2LI}$	Line Regulation	$7V < V_{IN} < 14V$ $I_{O1,2} = 200mA$			50	mV
$\Delta V_{O1,2LO}$	Load Regulation	$5mA < I_{O1,2} < 0.6A$			100	mV
$I_Q$	Quiescent Current	$I_{O1} = 10mA$ Output 2 Disabled			2	mA
$V_{O1RST}$	Reset Threshold Voltage	$(K = V_{O1})$	K-0.4	K-.25	K-0.1	V
$V_{RTH}$	Reset Threshold Hysteresis	(see note 1)	20		75	mV
$t_{RD}$	Reset Pulse Delay at Pin 5	$C_e = 100nF$ (see note 1)		25		ms
$V_{RL}$	Saturation Volt. at Pin 5 in Reset Condition	$I_5 = 5mA$			0.4	V
$I_{RH}$	Leakage Current at Pin 5 in Normal Condition	$V_5 = 10V$			10	$\mu A$
$K_{O1,2}$	Output Volt. Thermal Drift	$K_0 = \frac{\Delta V_0 \cdot 10^6}{\Delta T \cdot V_0}$ $T_J = 0 \text{ to } +125^\circ C$		100		ppm/ $^\circ C$
$I_{O1,2SC}$	Short Circ. Output Current	$V_{IN} = 7V$			1.6	A
		$V_{IN} = 18V$ (see note 2)			0.7	A
$V_{DISH}$	Disable Volt. at Pin 3 High (out 2 active)		2			V
$V_{DISL}$	Disable Volt. at Pin 3 Low (out 2 disabled)				0.8	V
$I_{DIS}$	Disable Bias Current at Pin 3	$0V < V_{DIS} < 7V$	-100		2	$\mu A$
$T_{Jsd}$	Junction Temp. for Thermal Shut Down			145		$^\circ C$

Notes : 1. If the output voltage OUT 1 goes below 4.85V ( $V_{OUT} - 0.25V$ ) the comparator "a" (see fig. 1) discharge rapidly the capacitor  $C_e$  and the Reset output (pin 5) goes at once LOW.

When the voltage at the OUT 1 rises above 4.9V, the voltage at pin 2 increases with this law :

$$t_d = \frac{C_e \cdot 2.5V}{10\mu A} \quad (\text{see fig. 2})$$

as  $V_2$  reach 2.5V the Reset output (pin 5) goes HIGH again. To avoid glitches in the Reset output the second comparator "b" has a large hysteresis (1.9V).

2. The output short circuit currents are tested one channel at time.

During a short circuit a large consumption of power occurs, anyway the thermal protection circuit guarantees the temperature not overcomes high value.

Figure 1.

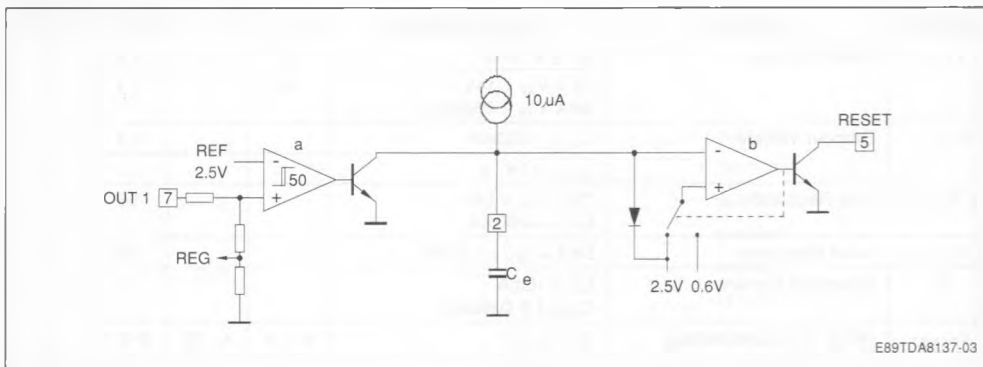
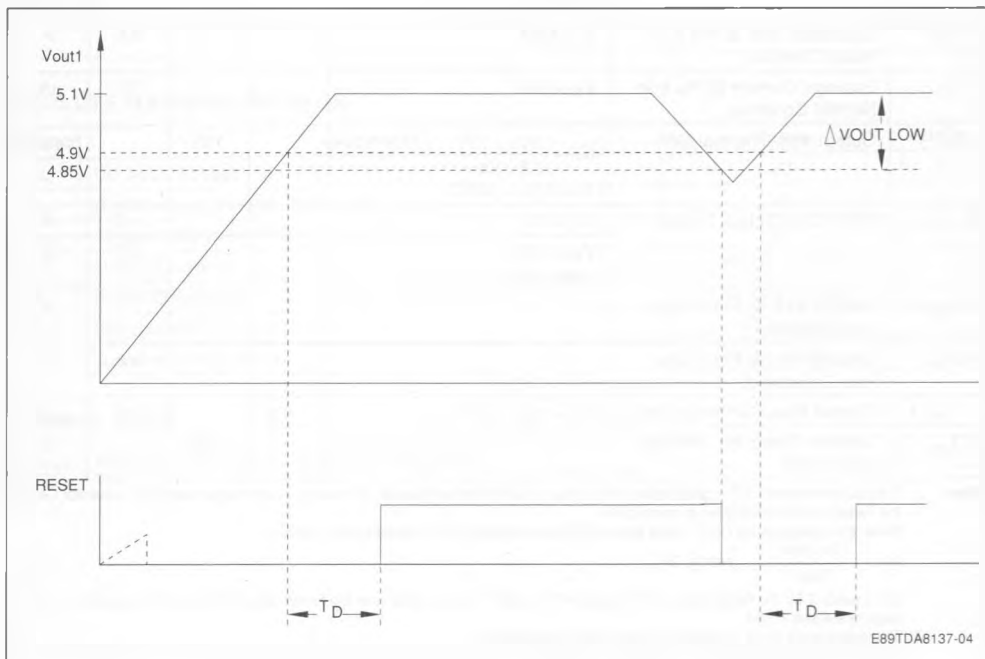
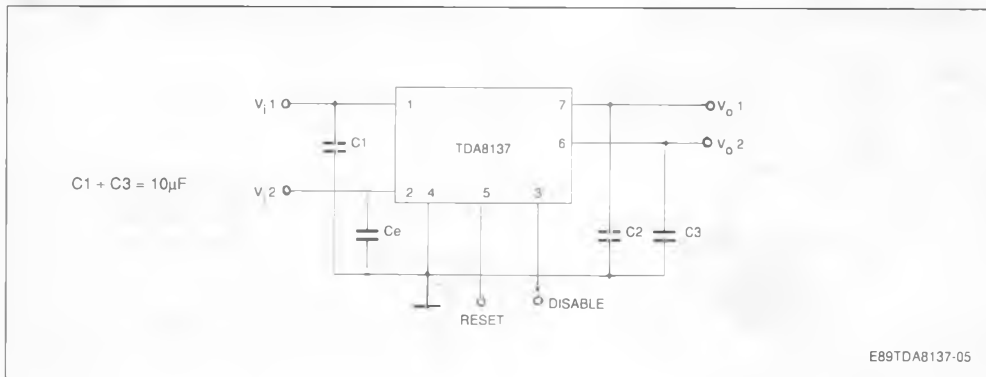

Figure 2.



## TYPICAL APPLICATION CIRCUIT



## CIRCUIT DESCRIPTION

The TDA8137 is a dual voltage regulator with Reset and Disable.

The two regulation parts are supplied from one voltage reference circuit trimmed by zener zap during EWS test.

The outputs stage have been realized in darlington configuration with a drop typical 1.2V.

The disable circuit, switch-off the output 2 if a voltage lower than 0.8V is applied at pin 3.

The Reset circuit controls the voltage at the output 1, if this one decrease below 4.85V provides to generate a reset pulse at pin 5 (open collector) with a certain delay depending by an external capacitor connected at pin 2.

PACKAGE MECHANICAL DATA

HEPTAWATT – PLASTIC PACKAGE

