

**LOW-DROP VOLTAGE REGULATOR**

- $V_O = 5\text{ V} \pm 4\%$  ( $I_O = 5\text{ mA}$ )
- $I_{OS} \geq 500\text{ mA}$
- $V_I - V_O \leq 0.6\text{ V}$  ( $I_O = 500\text{ mA}$ )
- $V_I$  (surge) =  $\pm 80\text{ V}$
- THERMAL AND SHORT-CIRCUIT PROTECTION

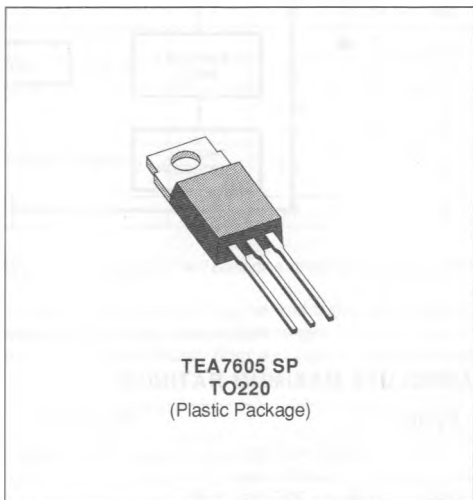

**PIN CONNECTIONS**

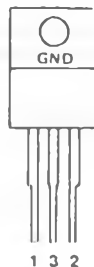

E88TEA7605-02

1 =  $V_I$   
2 =  $V_O$   
3 = GND

**DESCRIPTION**

TEA7605 is a low-drop 5 V regulator well suited to supplying stabilized voltage to  $\mu$ Ps in harsh industrial environment.

Special care was taken to keep :

- Lowest possible quiescent current (250  $\mu$ A).
- Lowest possible output capacitor (1  $\mu$ F).

## BLOCK DIAGRAM

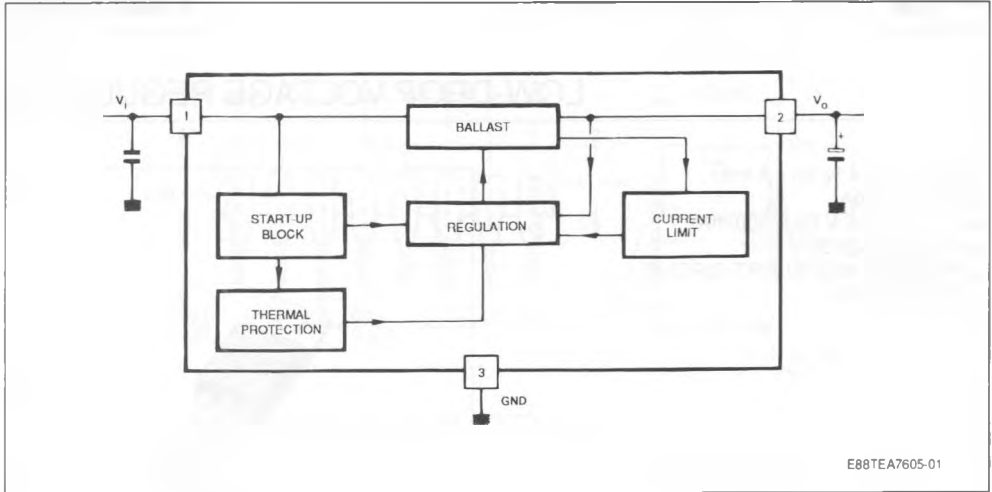

## ABSOLUTE MAXIMUM RATINGS

Symbol	Parameter	Value	Unit
$V_i$	Input Voltage - Continuous - $\tau = 300$ ms	30	V
		80	V
$V_r$	Reverse Input Voltage - Continuous - $\tau = 120$ ms	- 18	V
		- 80	V
$T_j$	Operating Junction Temperature Range	- 45 to 150	$^{\circ}\text{C}$
$T_{stg}$	Storage Temperature Range	- 55 to 150	$^{\circ}\text{C}$

## THERMAL DATA

$R_{th(j-c)}$	Junction-case Thermal Resistance	3	$^{\circ}\text{C}/\text{W}$
$R_{th(j-a)}$	Junction-ambient Thermal Resistance	70	$^{\circ}\text{C}/\text{W}$

## APPLICATION DIAGRAM

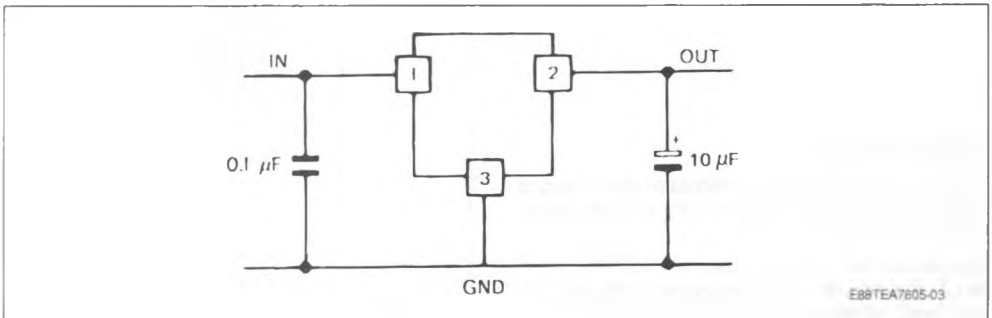

**ELECTRICAL OPERATING CHARACTERISTICS**

$T_j = 25\text{ }^\circ\text{C}$ ,  $V_i = 14.4\text{ V}$  (unless otherwise specified) Output Capacitor =  $10\text{ }\mu\text{F}$  (see note)

Symbol	Parameter	Min.	Typ.	Max.	Unit
$V_o$	Output Voltage ( $I_o = 5$ to $500\text{ mA}$ )	4.875	5	5.125	V
$V_i$	Input Supply Voltage (permanent)			28	V
$I_{cc}$	Current Consumption $I_o = 0\text{ mA}$ $I_o = 150\text{ mA}$ $I_o = 500\text{ mA}$		0.25 10 75	0.35 20 100	mA mA mA
$kV_i$	Line Regulation ( $V_i = 6$ to $26\text{ V}$ ; $I_o = 5\text{ mA}$ )		5	10	mV
$kV_o$	Load Regulation ( $I_o = 5$ to $500\text{ mA}$ )		40	60	mV
$V_i - V_o$	Drop-out Voltage $I_o = 150\text{ mA}$ $I_o = 500\text{ mA}$		0.18 0.4		V V
SVRR	Supply Voltage Rejection ( $I_o = 350\text{ mA}$ , $f = 120\text{ Hz}$ , $C_o = 1\text{ }\mu\text{F}$ , $V_i = 12 \pm 5\text{ V}$ )		60		dB
$I_{os}$	Short-circuit Output Current	0.5	0.7		A

**NOTE : APPLICATIONS HINTS**

The output capacitor has a direct influence on output voltage stability. A  $10\text{ }\mu\text{F}$  capacitor will provide satisfactory results ; there is no upper limit.

If necessary, this value can be reduced down to  $1\text{ }\mu\text{F}$  ; however, in such case, it should be checked that output capacitor keeps sufficiently high capacitance and low equivalent series resistance in the whole temperature range.

Such low capacitor value is not recommended either, if output current is to switch abruptly from very high to very low values (for instance,  $400\text{ mA}$  to  $< 1\text{ mA}$ ).

**ELECTRICAL OPERATING CHARACTERISTICS**

$T_j = -45\text{ }^\circ\text{C}$  to  $+125\text{ }^\circ\text{C}$ ,  $V_i = 14.4\text{ V}$  (unless otherwise specified) Output Capacitor =  $10\text{ }\mu\text{F}$

Symbol	Parameter	Min.	Typ.	Max.	Unit
$V_o$	Output Voltage ( $I_o = 5$ to $500\text{ mA}$ )	4.8	5	5.2	V
$\frac{dV_o}{dT_i}$	Output Voltage Drift $-45$ to $25\text{ }^\circ\text{C}$ $25$ to $125\text{ }^\circ\text{C}$	$-0.4$ $-0.6$			mV/ $^\circ\text{C}$
$I_{cc}$	Current Consumption $I_o = 0\text{ mA}$ $I_o = 150\text{ mA}$ $I_o = 500\text{ mA}$			0.4 25 120	mA mA mA
$KV_i$	Line Regulation ( $V_i = 6$ to $26\text{ V}$ $I_o = 5\text{ mA}$ )			20	mV
$KV_o$	Load Regulation ( $I_o = 5$ to $500\text{ mA}$ )			80	mV
$V_i - V_o$	Drop-out Voltage $I_o = 150\text{ mA}$ $I_o = 500\text{ mA}$		0.2		V V
$I_{os}$	Short Circuit Output Current	0.5			A

PACKAGE MECHANICAL DATA

TO220 – PLASTIC PACKAGE

