

## Automotive Lamp Outage Monitor

### Description

The U2481B and the U2482B multicomparator circuits are designed to monitor automotive illumination by sensing the voltage drop across shunt resistors. Provided with extremely low comparator thresholds, these ICs can be used together as a chip set to build an entire lamp monitor system. Single operation of both circuits is also possible.

As a special feature for brake lamp monitoring, the U2481B contains a latch stage connected to one of its triple comparators.

### Features

- Extremely low comparator thresholds of typically 3.5 mV
- Internal compensation for copper shunts
- Internal compensation for voltage-dependent bulb characteristic
- Comparator input voltage may exceed supply voltage
- Internal protection measures for pulses according to ISO TR 7637/1
- ESD according to MIL-SID-883 C test method 3015.7
  - Human body model: 4 kV
  - Machine model: 200 V
- EMI protection (TEM cell up to 100 V/m)

### Applications

Both ICs can be used in any kind of vehicle with a 12 V supply. It is sufficient to insert small resistors into the lamp wiring and to provide the dashboard instrument

With

- 4 single comparators
- 1 double comparator and
- 2 triple comparators

each of the integrated circuits monitors up to 12 lamps and up to 6 fuses.

All comparator stages are combined together to control the common output stage.

### Benefits

- Extremely low threshold voltage gives low voltage drop via shunt resistor. Power dissipation of the lamp monitor module is minimized
- Perfect EMC in conjunction with an appropriate pc board layout

cluster with a pilot lamp. These ICs increase the safety and add comfort features.

## Block Diagram

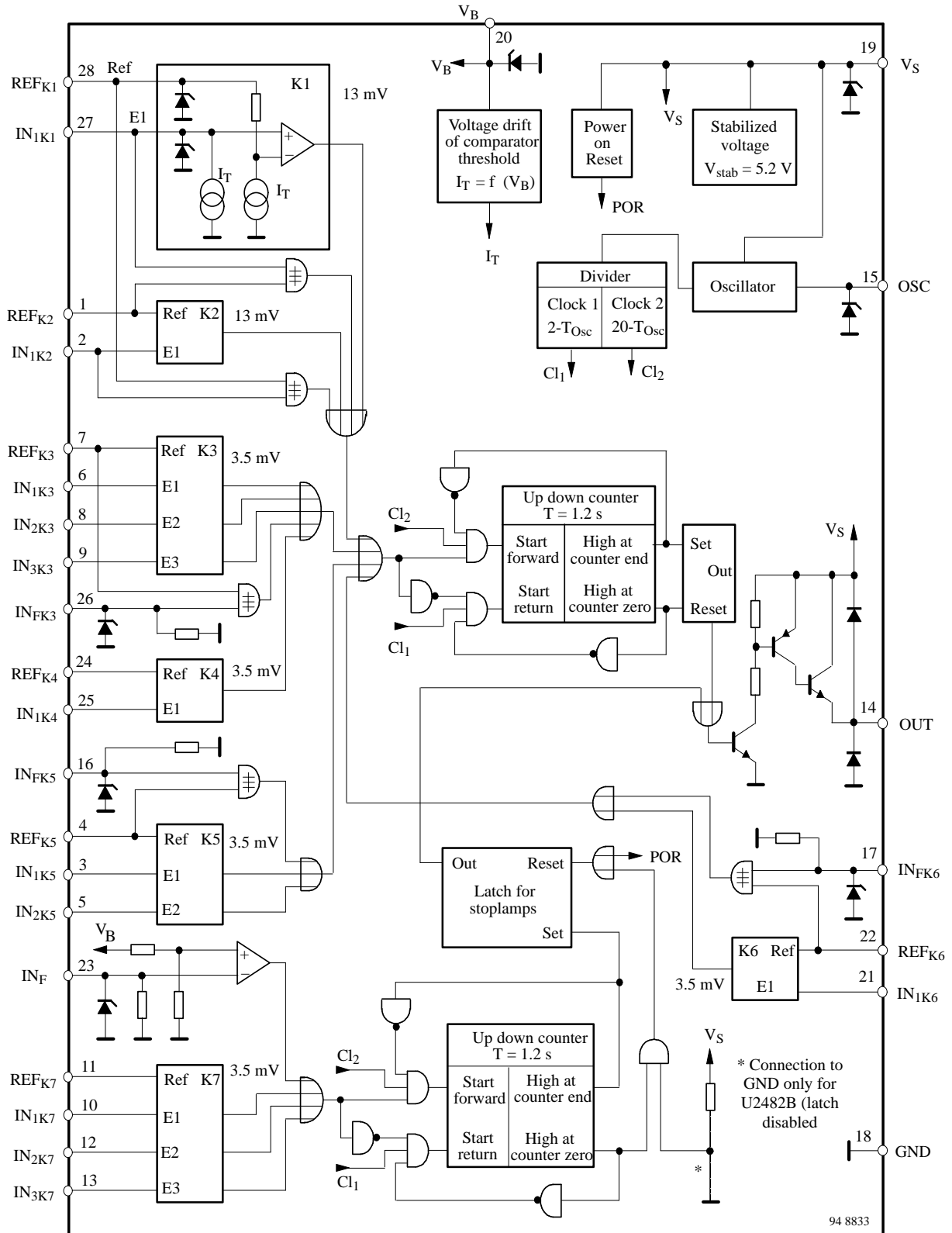

Figure 1.

### Pin Description

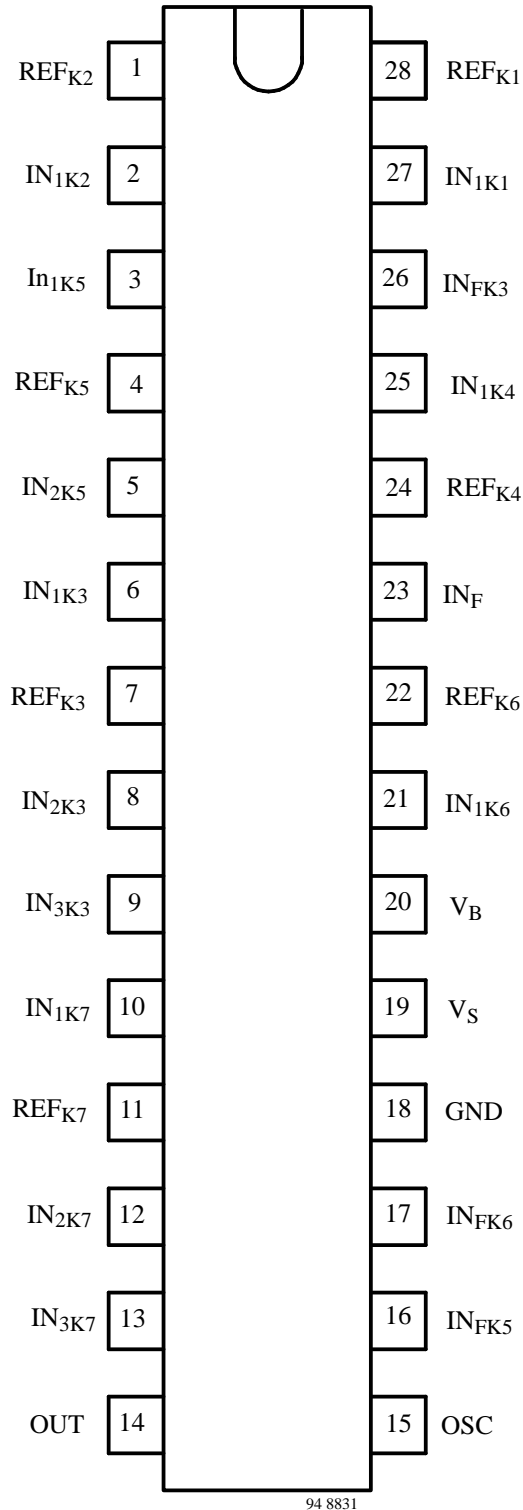
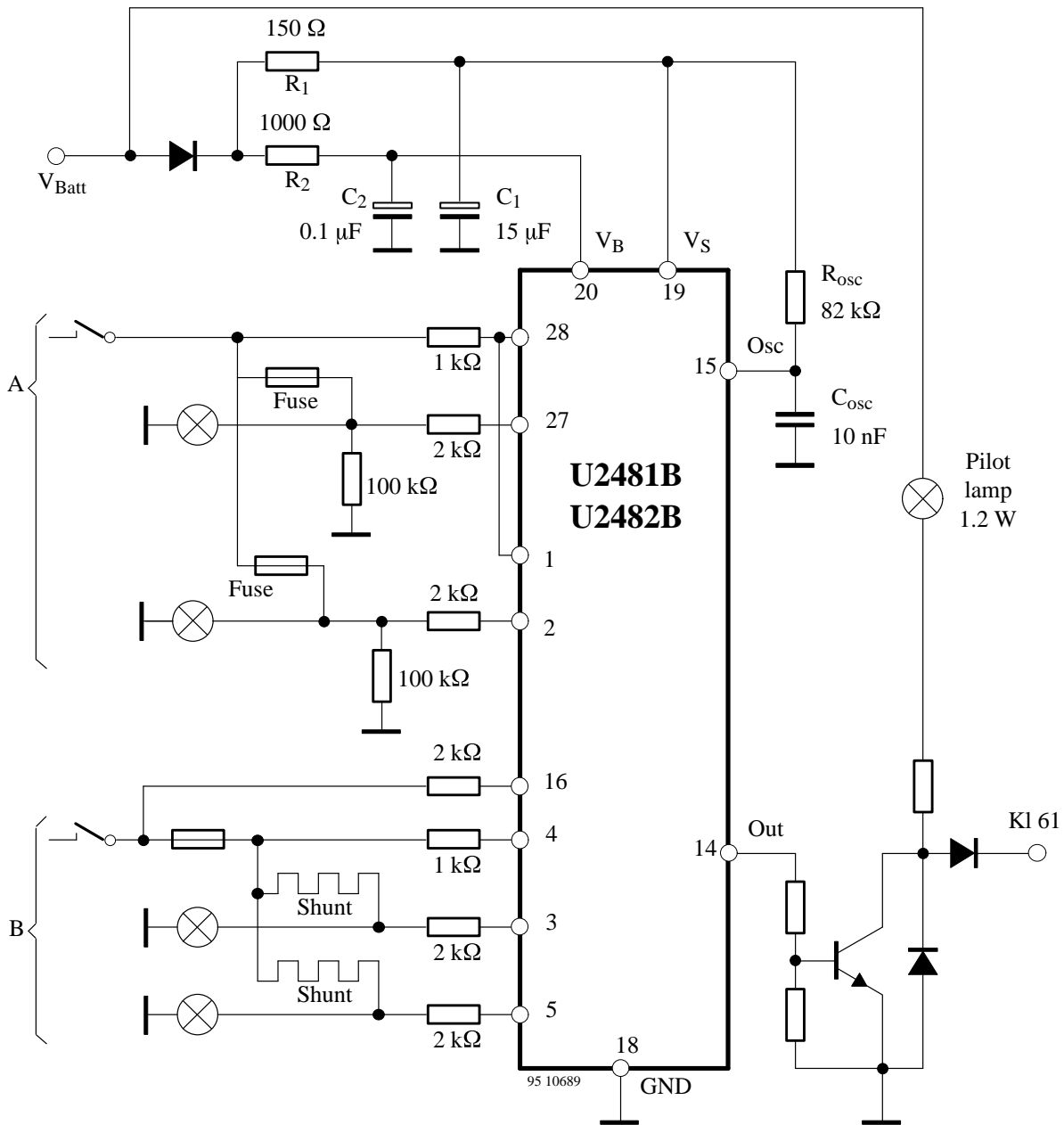

Figure 2. Pin configuration

Pin	Symbol	Function
1	REF <sub>K2</sub>	Reference for threshold voltage single comparator K2
2	IN <sub>1K2</sub>	Input 1; single comparator K2
3	IN <sub>1K5</sub>	Input 1; double comparator K5
4	REF <sub>K5</sub>	Reference for threshold voltage; double comparator K5
5	IN <sub>2K5</sub>	Input 2; double comparator K5
6	IN <sub>1K3</sub>	Input 1; triple comparator K3
7	REF <sub>K3</sub>	Reference for threshold voltage; triple comparator K3
8	IN <sub>2K3</sub>	Input 2; triple comparator K3
9	IN <sub>3K3</sub>	Input 3; triple comparator K3
10	IN <sub>1K7</sub>	Input 1; triple comparator K7 (U2481B with latch)
11	REF <sub>K7</sub>	Reference for threshold voltage; triple comparator K7 (U2481B with latch)
12	IN <sub>2K7</sub>	Input 2; triple comparator K7 (U2481B with latch)
13	IN <sub>3K7</sub>	Input 3; triple comparator K7 (U2481B with latch)
14	OUT	Output for pilot lamp
15	OSC	R/C combination for oscillator
16	IN <sub>FK5</sub>	Fuse monitor input ; double comparator K5
17	IN <sub>FK6</sub>	Fuse monitor input; single comparator K6
18	GND	Ground
19	V <sub>S</sub>	Supply voltage
20	V <sub>B</sub>	Reference voltage of comparators
21	IN <sub>1K6</sub>	Input1; single comparator K6
22	REF <sub>K6</sub>	Reference for threshold voltage; single comparator K6
23	IN <sub>F</sub>	Input; brake fuse comparator
24	REF <sub>K4</sub>	Reference for threshold voltage; single comparator K4
25	IN <sub>1K4</sub>	Input 1; single comparator K4
26	IN <sub>FK3</sub>	Fuse monitor input; triple comparator K3
27	IN <sub>1K1</sub>	Input 1; single comparator K1
28	REF <sub>K1</sub>	Reference for threshold voltage; single comparator K1



- A: Example of 2 “single comparators” using the fuses as shunt resistors. (Both comparators are internally EXOR connected, see block diagram.)
- B: Example of a “double comparator” using copper shunts and additional fuse monitoring

Figure 3. Basic application diagram

## Functional Description

### Power Supply, Pins 19 and 20

The ICs have two supply pins. The IC itself is supplied via Pin 19 (stabilized voltage, POR-circuitry). Pin 20 supplies only the current sources of the comparators. Both pins have an internal 21 V Zener Diode for protection. For reasons of interference protection and surge immunity the supply voltage pins have to be provided with RC-circuitries as shown in figure... The resistors limit the current in the case of overvoltage, whereas the capacitors smooth the supply voltage.

Recommended values:

Pin 19:  $R_1 = 150 \Omega$ ;  $C_1 = 15 \mu\text{F}$

Pin 20:  $R_2 = 1000 \Omega$ ;  $C_2 = 0.1 \mu\text{F}$

An external diode protects the IC against battery reversal.

### Power-On-Reset

When the supply voltage is switched on, a power-on-reset pulse is generated internally which resets the brake lamp monitor latch and the counter stages.

### Oscillator, Pin 15

The RC-oscillator is the time base for clock 1 and clock 2 (see block diagram) which are desired from a divider stage and fed to the two upward and downward counters.

The oscillator frequency  $f_{\text{osc}}$  is mainly determined by the external R/C components and an integrated resistor. The capacitor K is charged by the external resistor and discharged by the integrated one. Because of the temperature characteristic and the tolerances of the integrated 2 k $\Omega$ -resistor, the external one has to have considerable higher value in order to achieve a stable frequency.

Calculation of the frequency:

$$f_{\text{osc}} = \frac{1}{f_{\text{osc}}} = \frac{1}{C_{\text{osc}}} \times (0.74 R_{\text{osc}} + 2260 \Omega)$$

With the recommended values

$R_{\text{osc}} = 82 \text{ k}\Omega$  and  $C_{\text{osc}} = 10 \text{ nF}$

$f_{\text{osc}} \approx 1.58 \text{ kHz}$

### Comparators

**Comparators K1 and K2:** threshold voltage of typically  $V_{\text{th}} = 13 \text{ mV}$ ; designed to monitor high- and low-beam bulbs, where the fuses can be used as shunt resistors.

**Comparators K3 to K7:** threshold voltage of typically  $V_{\text{th}} = 3.5 \text{ mV}$ ; designed for all other monitor purposes. Due to the integrated compensation circuitry, these comparators are suitable for pc layer copper shunts.

A bulb is detected as “good” as long as the voltage drop via the shunt resistor exceeds the threshold voltage. The pilot lamp is off. A failed bulb is detected if the voltage drop via the shunt resistor is smaller than the threshold voltage. The pilot lamp is on. An external transistor is necessary to drive the pilot lamp.

In order to disable monitoring when the lamps are switched off, therefore the comparator outputs are disabled if the reference voltage  $V_{\text{ref}} < V_{\text{Min}}$  with  $V_{\text{Min}} = 0.33 \times V_{\text{B}}$ .

As protection against transients on the supply, all comparator inputs require external resistors. Their tolerances directly influence the comparator threshold accuracy. Resistors with a  $\pm 1\%$  tolerance are recommended.

**Single comparators:** The inputs (K1, K2, K4, K6) sink currents of typically 10  $\mu\text{A}$  each. During switch-over, the currents of reference and input pins are identical. Therefore identical external protection resistors ( $R = 1 \text{ k}\Omega$ ) are required.

**Double comparator:** The reference input (K5) sinks a current of typically 20  $\mu\text{A}$ ; its inputs sink currents of typically 10  $\mu\text{A}$  each during switch-over. Therefore the external protection resistors must provide  $R = 1 \text{ k}\Omega$  for  $\text{REF}_{\text{K5}}$  and  $R = 2 \text{ k}\Omega$  each for  $\text{IN}_{1\text{K5}}$  and  $\text{IN}_{2\text{K5}}$ .

**Triple comparators:** The reference inputs (K3 and K7) sink currents of typically 30  $\mu\text{A}$ . All inputs ( $\text{IN}_{1\text{K3}}$ ,  $\text{IN}_{2\text{K3}}$ ,  $\text{IN}_{3\text{K3}}$ , and  $\text{IN}_{1\text{K7}}$ ,  $\text{IN}_{2\text{K7}}$ ,  $\text{IN}_{3\text{K7}}$ ) sink the identical typical current of 10  $\mu\text{A}$  during switch-over. Therefore the external protection resistor must provide  $R = 1 \text{ k}\Omega$  for  $\text{REF}_{\text{K3}}$  and  $\text{REF}_{\text{K7}}$  and  $R = 3 \text{ k}\Omega$  at each input.

### Fuse Monitoring

The internal EXOR conjunction of comparators K1 and K2 allows fuse monitoring for both lamps. Even a simultaneous blowout of both fuses is detected.

The pins  $\text{IN}_{\text{FK3}}$ ,  $\text{IN}_{\text{FK5}}$  and  $\text{IN}_{\text{FK6}}$  with their EXOR gates can be used for additional fuse monitoring.

Detection threshold for a blown fuse is  $V_{\text{ref}} < V_{\text{Min}}$  with  $V_{\text{Min}} = 0.33 \times V_{\text{B}}$  ( $V_{\text{B}}$  = reference voltage of comparators).

Pin  $\text{IN}_{\text{F}}$  is used for brake fuse monitoring. With a voltage drop  $V_{\text{F}} > 4.8 \text{ V}$  across the fuse, the comparator detects a blown fuse. A voltage drop  $V_{\text{F}} < 2.8 \text{ V}$  represents a “good” fuse. U2481B’s comparator K7 is connected to a latch, thus a brake lamp outage is memorized.

## Integrated Delay, Debouncing, Failure Display

As soon as a comparator detects a failure a slow upward counter is started in order to generate the delay time,  $t_{del} = 1.2$  s. With a consistent failure the output stage is enabled after  $t_{del}$ . If the failure disappears during  $t_{del}$  a fast downward counter is started in order to generate the reset time  $t_{reset} \cong 135$  ms. The upward counter is reset, the output stage stays disabled.

Benefits: Intermittent contacts in the wire harness do not activate the pilot lamp! Even cyclical intermittent contacts are screened out as long as the pulse/pause ratio is smaller than 10:1. In the case of higher duty cycles the upward counter may reach its trigger threshold for the output activation after  $t > t_{del}$ .

Individual delay- and reset times can be adjusted with external R/C components according to (see "oscillator")

- $t_{del} = 1930 \times t_{osc}$
- $t_{reset} = 198 \times t_{osc}$

## Latch for Brake Lamp Monitor

A failure of a brake lamp detected by comparator K7 or a blown fuse in the brake circuitry is memorized after the delay time has expired.

A reset of the latch can only be performed with a "power-on-reset".

## Output Stage

The output is a PNP Darlington stage with protection diodes to  $V_S$  and IC ground. The output is designed to drive an external pilot lamp with an external NPN transistor.

At the end of the delay time the output stage is switched on and can source a current of  $I_{out} = -10$  mA with a typical saturation voltage of  $V_{sat} = 1$  V.

## Test Mode

With  $V_{TEST} = 23$  V (20 mA) applied to Pin osc, via a 200  $\Omega$  resistor the delay time stage can be bypassed for test purposes. A failure detection will be displayed immediately to save time during threshold testing.

## Application Hints

### Layout Recommendations for Copper Layer Shunts

Lamp outage monitor systems can be produced most cost-efficiently if stamped shunt resistors are replaced by copper layer shunts which are generated with the pc board layout.

The U2481B and the U2482B are suitable for this application because of their comparator thresholds, which are compensated in reference to the temperature characteristic of copper.

A constant lamp current,  $I_{LAMP} = V_{Th}/R_{sh}$  with threshold voltage  $V_{Th} = f(T)$  and shunt resistor  $R_{sh} = f(T)$ , is achieved if the comparator threshold and the shunt resistor have identical temperature characteristics. With the temperature coefficient of copper  $\alpha_{cu} = 3.9 \cdot 10^{-3}$  1/K, a copper shunt changes its nominal value by 52% if the automotive ambient temperature range of  $t_{amb} = -40$  to  $+95^\circ\text{C}$  is taken into consideration.

Examples for sheet resistances of copper shunts ( $T_{amb} = 25^\circ\text{C}$ ):

$R_A = 0.5 \text{ m}\Omega/\text{square}$  (35.1  $\mu\text{m}$  layer thickness)

$R_A = 0.25 \text{ m}\Omega/\text{square}$  (70  $\mu\text{m}$  layer thickness)

### How to Lay Out Copper Shunts (figure 3)

The width of the copper trace has to be selected in reference to a low current-effected temperature increase.

The copper trace must be capable of peak currents which do not blow the fuse. The peak currents are specified by the car manufacturers.

Example:

A 7.5 A fuse allows a peak current of 26 A (1 s), 15 A (10 s) or 10 A (60 s).

The copper shunt length has to be calculated between the two sense connections to the comparator. The connection of the common reference input of double and triple comparators has to be considered carefully.

Calculation example for a copper shunt used with a 4 W bulb.

$I_{LAMP} = 0.325 \text{ A}$

Failure criterion:  $I = 1/2 * I_{LAMP}$

10 A fuse is capable of  $I = 13.5 \text{ A}$

Copper layer thickness: 70  $\mu\text{m}$

Comparator threshold voltage (U2481B, U2482B):

$V_{Th} = 3.5 \text{ mV}$

Assumed copper width for temperature increase

$\Delta T_{cu} < 50^\circ\text{C}$ :

$W_{cu} = 2.5 \text{ mm}$  (13.5 A, 70  $\mu\text{m}$ )

Two equations for calculation of the shunt resistance:

$$R_{shunt} = R_A * L/W_{cn}$$

(with  $R_A = \text{Cu sheet resistance}$ )

$$R_{shunt} = V_{Th} / 1/2 I_{LAMP}$$

Thus the length of copper shunt is calculated as:

$$L = 2 * V_{Th} * W_{cn} / R_A * I_{LAMP}$$

$$L = 215 \text{ mm}$$

For a reasonable pc-layout a meander-shaped shunt resistor is recommended. The high lamp currents may cause hot spots at sharp edges of the copper shunts. That may deteriorate accuracy of the measurement. Therefore it is recommended to layout the copper shunts with smoothed curves.

In accordance to figure...the meander may be formed by 4 straight tracks (length  $L_S$  each) and 3 connecting  $180^\circ$  arcs (length  $L_{are}$  are each). If the mean arc radius is selected to  $r = W_{cn}$  the arc length becomes  $L_{are} = \pi * W_{cn}$ .

Thus the total length is

$$L = 4 * L_S + 3 * L_{are}$$

$$= 4 * L_S + 3 * \pi * W_{cn}$$

With  $L = 215 \text{ mm}$  the track length becomes

$$L_S = \frac{1}{4} (L - 3 * \pi * W_{cn})$$

$$L_S = 47.8 \text{ mm}$$

### Using Fuses as Shunt Resistors

This cost saving method can be used if the following assumptions are fulfilled:

- Each lamp needs a dedicated fuse
- The fuse socket is mounted within the monitor module to connect the sense lines are suitable for this monitor
- task because of their comparator thresholds are compensated for the fuse temperature coefficient of  $\alpha_F = 4.1 * 10^{-3}$  1/K

### Calculation Example for a 55 W Bulb and a 7.5 A fuse:

Measured voltage drop across the fuse:  $V_F = 52 \text{ mV}$

Measured current:  $I_{LAMP} = 4.2 \text{ A}$

Calculated resistance:  $R_F = 12.4 \text{ m}\Omega$

Selected comparator threshold:

$V_{Th} = 1/4 V_F = 13 \text{ mV}$  (typically);

With a lamp current  $I_{LAMP} < V_{Th}/R_F = 1.05 \text{ A}$

the comparator detects a blown fuse.

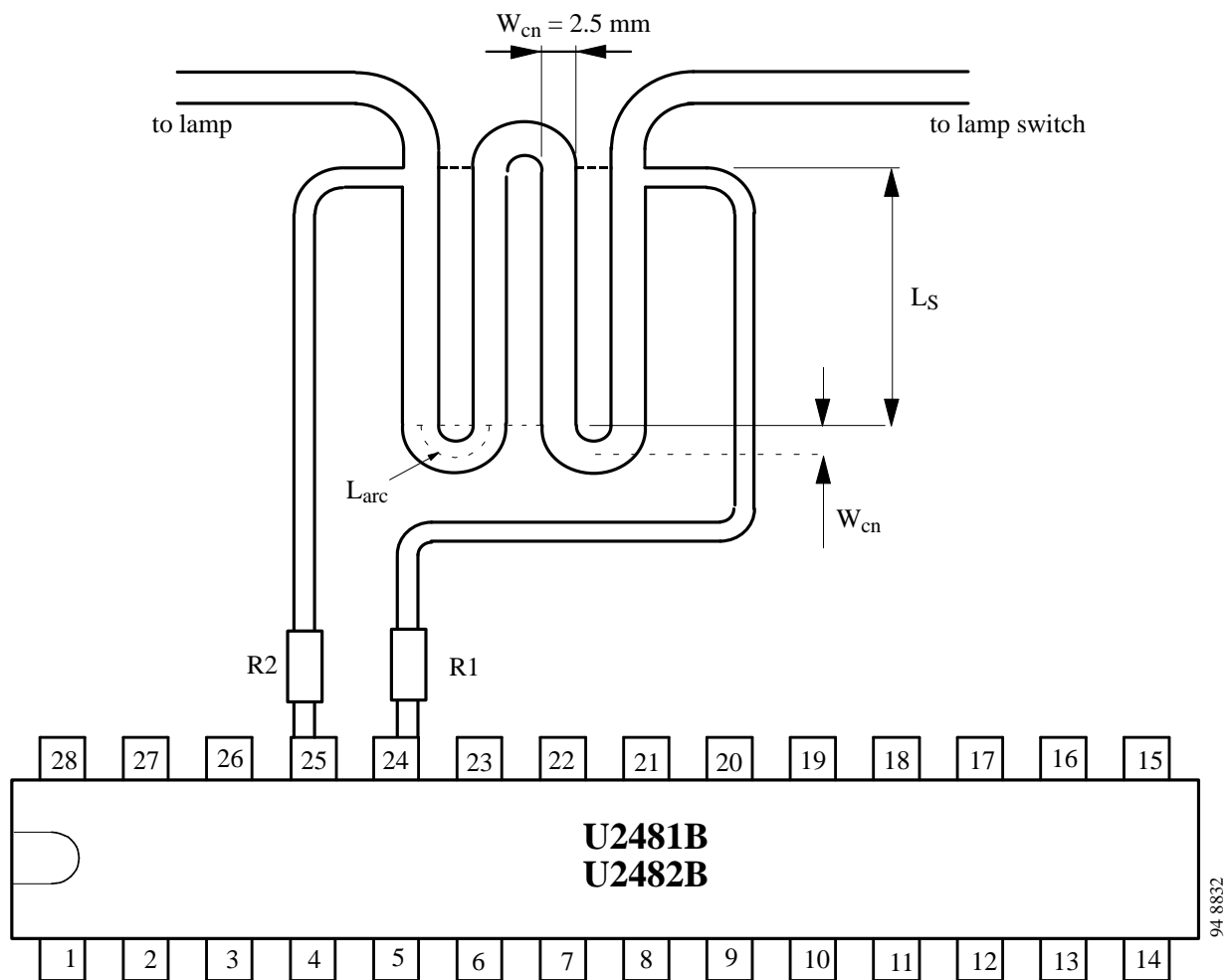

Figure 4. Design example for a copper shunt with meander shape

### Absolute Maximum Ratings

Parameters	Symbol	Value	Unit
Supply voltage	$V_S, V_{Batt}$	16.5	V
Pulse current (2 ms)	$I_S$	1.1	A
Short circuit current (reversed battery)	$I_{SC}$	170	mA
Output current	$I_{out}$	-12	mA
Junction temperature	$T_j$	150	°C

### Thermal Resistance

Parameters	Symbol	Value	Unit
Thermal resistance SO 28	$R_{thJA}$	110	K/W
Ambient temperature range	$T_{amb}$	-40 to +100	°C
Storage temperature range	$T_{stg}$	-55 to +125	°C



## Electrical Characteristics

$T_{amb} = -40$  to  $+100^{\circ}\text{C}$ ,  $V_{Batt}$  (Kl. 15) = 10 to 15 V, supply series resistors and input protection resistors connected (see figure 1 “block diagram” and figure 2 “basic application schematic”) unless otherwise specified.

Parameters	Test Conditions / Pins	Symbol	Min.	Typ.	Max.	Unit	
<b>Supply</b>							
Operating voltage		$V_{Batt}$	9		16	V	
Supply current	$V_{Batt} = 13\text{ V}$ , $V_{14} = \text{low}$						
	Pin 20		0.3	0.7	1.1	mA	
	Pin 19		3	5	7	mA	
Power on reset (POR)	$T_{amb} = 25^{\circ}\text{C}$	Pin 19	3.0		4.2	V	
	$V_{Batt}$ (Kl. 15)		3.7		5.0	V	
<b>Comparators</b>							
Comparator input current during switch over	$V_{Batt} = 13\text{ V}$	Pins 27, 28 Pins 1, 2 Pins 24, 25 Pins 21, 22 Pin 7 Pins 6, 8, 9 Pin 11 Pins 10,12,13 Pin 4 Pins 3,5	$I_{27}, I_{28}$ $I_1, I_2$ $I_{24}, I_{25}$ $I_{21}, I_{22}$ $I_7$ $I_6, I_8, I_9$ $I_{11}$ $I_{10}, I_{12}, I_{13}$ $I_4$ $I_3, I_5$		10 10 10 10 30 10 30 10 20 10	$\mu\text{A}$	
Comparator thresholds $V_{T1}$ of comparators K1 and K2 ( $V_{T1} = V_{Ref...} - V_{IN...}$ )	$V_S = 10\text{ V}$ $V_S = 13\text{ V}$ $V_S = 15\text{ V}$	Pins 1, 2, 27, 28	$V_{T1x}$ $x = \text{Pin No.}$	8.5 10.0 11.0	11.5 13.0 14.0	14.5 16.0 17.0	mV
Voltage characteristic				0.5		mV/V	
Temperature characteristic				3900		ppm/ $^{\circ}\text{K}$	
Comparator thresholds $V_{T2}$ of comparators K3 to K7 ( $V_{T2} = V_{Ref...} - V_{IN...}$ )	$V_S = 10\text{ V}$ $V_S = 13\text{ V}$ $V_S = 15\text{ V}$	Pins 6, 7, 8, 9 Pins 24, 25 Pins 3, 4, 5 Pins 21, 22 Pins 10, 11, 12, 13	$V_{T1x}$ $x = \text{Pin No.}$	1.5 2.0 2.3	3.0 3.5 3.8	4.5 5.0 5.3	mV
Voltage characteristic				0.17		mV/V	
Temperature characteristic				3900		ppm/ $^{\circ}\text{K}$	
Min. comparator input voltage for detection	all Ref-pins		$V_{Min}$	$0.33 \times V_{Batt}$			
<b>Output</b>							
Output current	$V_{Batt} = 13\text{ V}$	Pin 14	$I_{14}$	-10.0		mA	
Output saturation voltage	$I_{out} = -10\text{ mA}$	Pin 19–Pin 14	$V_{Sat}$	1.0	1.5	V	

Parameters	Test Conditions / Pins	Symbol	Min.	Typ.	Max.	Unit
<b>Protection</b>						
Voltage of Zener diodes	Pin 19 Pin 20 all Ref... and IN... pins	$V_S$ $V_B$ $V_{Ref...}$ $V_{IN...}$		21 19 19		V
<b>Oscillator</b>						
Oscillator frequency	$R_{osc} = 82\text{ k}\Omega$ , $C_{osc} = 10\text{ nF}$ , Pin 15	$f_{osc}$		1.58		kHz
Delay time	$R_{osc} = 82\text{ k}\Omega$ , $C_{osc} = 10\text{ nF}$	$t_d$	1.1	1.2	1.3	s
Debounce time	$R_{osc} = 82\text{ k}\Omega$ , $C_{osc} = 10\text{ nF}$	$t_{db}$	115	125	135	ms
<b>Break fuse</b>						
Brake fuse detection threshold	$V_{Batt}$ Pin 23	$V_{TB}$	2.8	3.8	4.8	V
Input current	$V_{23} = 13\text{ V}$ Pin 23	$I_{23}$		100		$\mu\text{A}$
Trigger threshold (internal pull down resistor)	Pins 16, 17, 26	$V_{TTx}$ $\times=16,17,26$		$0.33 \times V_{Batt}$		V
Input current	$V_{Batt} = 13\text{ V}$	$I$		100		$\mu\text{A}$
<b>Test</b>						
Test voltage for delay time override	$I = 20\text{ mA}$ Pin 15	$V_{15}$		23		V

### Dimensions in mm

Package: SO 28

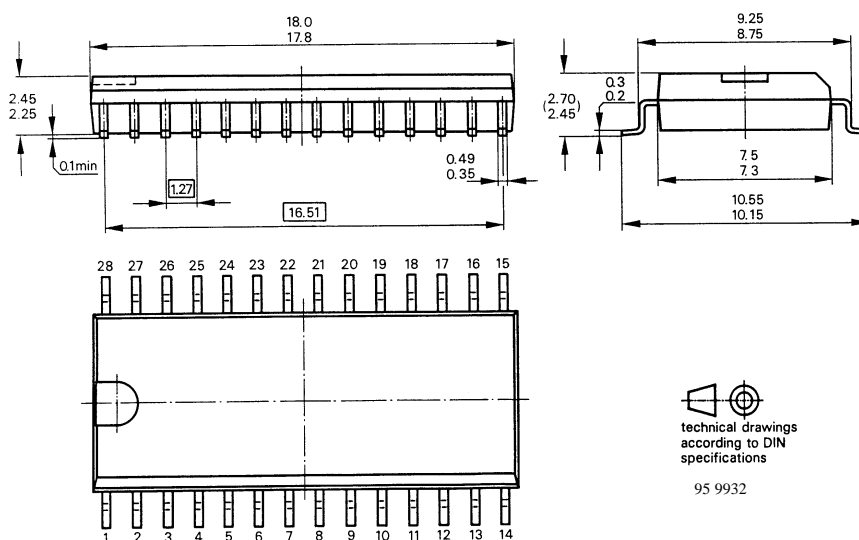

### Ozone Depleting Substances Policy Statement

It is the policy of **TEMIC TELEFUNKEN microelectronic GmbH** to

1. Meet all present and future national and international statutory requirements.
2. Regularly and continuously improve the performance of our products, processes, distribution and operating systems with respect to their impact on the health and safety of our employees and the public, as well as their impact on the environment.

It is particular concern to control or eliminate releases of those substances into the atmosphere which are known as ozone depleting substances (ODSs).

The Montreal Protocol (1987) and its London Amendments (1990) intend to severely restrict the use of ODSs and forbid their use within the next ten years. Various national and international initiatives are pressing for an earlier ban on these substances.

**TEMIC TELEFUNKEN microelectronic GmbH** semiconductor division has been able to use its policy of continuous improvements to eliminate the use of ODSs listed in the following documents.

1. Annex A, B and list of transitional substances of the Montreal Protocol and the London Amendments respectively
2. Class I and II ozone depleting substances in the Clean Air Act Amendments of 1990 by the Environmental Protection Agency (EPA) in the USA
3. Council Decision 88/540/EEC and 91/690/EEC Annex A, B and C (transitional substances) respectively.

**TEMIC** can certify that our semiconductors are not manufactured with ozone depleting substances and do not contain such substances.

**We reserve the right to make changes to improve technical design and may do so without further notice.**

Parameters can vary in different applications. All operating parameters must be validated for each customer application by the customer. Should the buyer use TEMIC products for any unintended or unauthorized application, the buyer shall indemnify TEMIC against all claims, costs, damages, and expenses, arising out of, directly or indirectly, any claim of personal damage, injury or death associated with such unintended or unauthorized use.

TEMIC TELEFUNKEN microelectronic GmbH, P.O.B. 3535, D-74025 Heilbronn, Germany  
Telephone: 49 (0)7131 67 2831, Fax number: 49 (0)7131 67 2423