

-3V to -15V Hot Swap Power Manager

FEATURES

- Integrated 0.1Ω Power MOSFET
- -3V to -15V Operation
- Programmable Electronic Circuit Breaker
- Digital Programmable Current Limit from 0A to 3A
- Programmable Maximum Output Current from 0A to 4A
- Programmable On Time
- Fixed 2% Fault Duty Cycle
- Thermal Shutdown
- Fault Output Indicator
- Power SOIC Package

DESCRIPTION

The UCC3920 Low RDSon Hot Swap Power Manager provides complete power management, hot swap capability, and circuit breaker functions. The only component needed to operate the device, other than supply bypassing, is the fault timing capacitor, CT. All control and housekeeping functions are integrated and externally programmable. These include the fault current level, maximum output sourcing current, maximum fault time, and start up delay. In the event of a constant fault, the internal fixed 2% duty cycle ratio limits the average output power.

The internal 3 bit DAC allows programming of the fault level current from 0mA to 500mA with 250mA resolution, and from 500mA to 3A with 500mA resolution. The IMAX control pin sets the maximum sourcing current to 1A above the fault level when driven low, and to a full 4A when driven high for applications which require fast output charging.

When the output current is below the fault level, the output MOSFET is switched on with a nominal resistance of 0.1Ω. When the output current exceeds the fault level or the maximum sourcing level, the output remains on, but the fault timer starts charging CT. Once CT charges to a preset threshold, the switch is turned off, and remains off for 50 times the programmed fault time. When the output current reaches the maximum sourcing level, the MOSFET transitions from a switch to a constant current source, regulating the output current at a constant level.

Other features include an Open Drain Fault Output Indicator, Thermal Shutdown, Undervoltage Lockout, -3V to -15V operation, and a low thermal resistance Small Outline Power Package. All level shifting is done internally, which means that the DAC, IMAX and Shutdown Inputs can be driven from the logic supply. The fault output is also referenced to the logic GND, so this can easily interface back to the logic supply.

BLOCK DIAGRAM

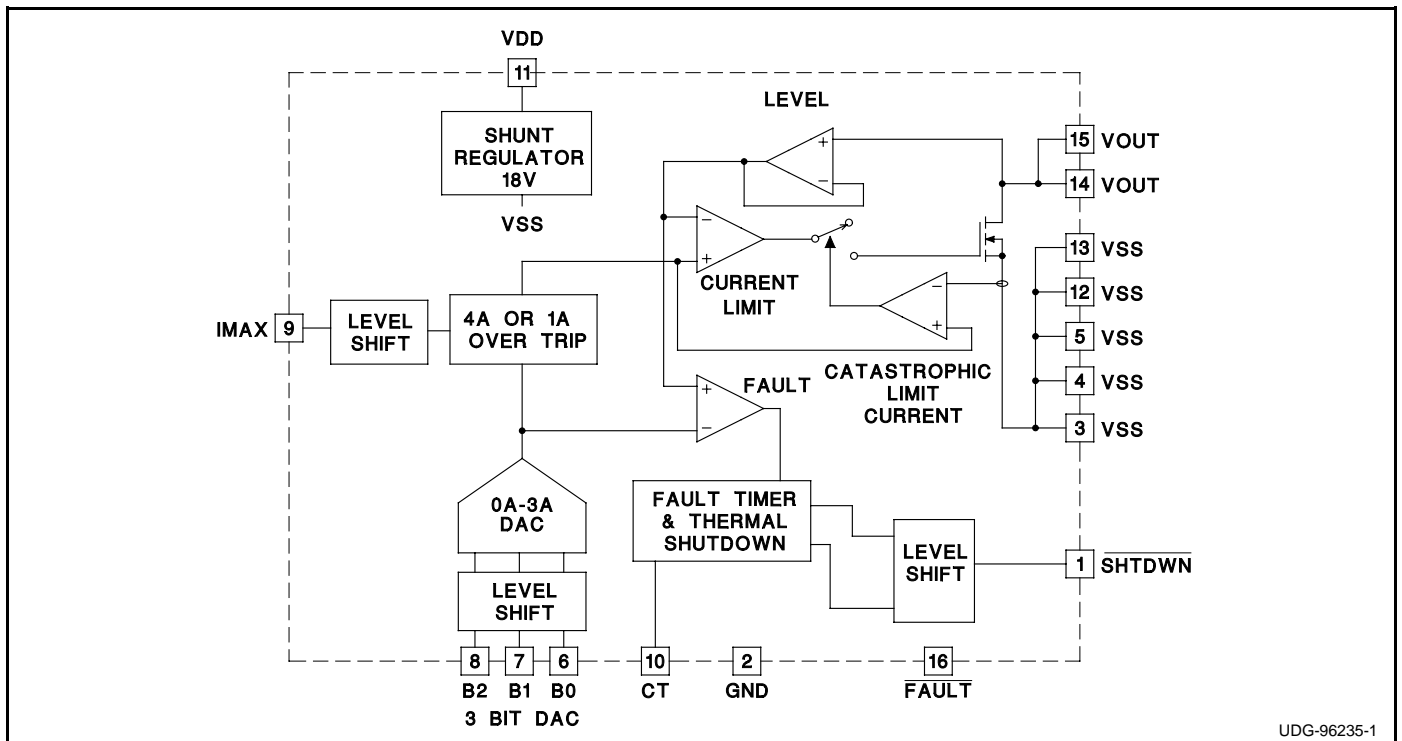

ABSOLUTE MAXIMUM RATINGS

Input Supply Voltage	
(VDD).....	+7V
(VSS).....	-15V
Maximum Differential Supply (VDD - VSS).....	18V
Maximum Supply Shunt Current	20mA
Fault Output Sink Current.....	20mA
Fault Output Voltage.....	7V
Output Current (DC).....	Internally Limited
TTL Input Voltage.....	-0.3 to 7V
Storage Temperature.....	-65°C to +150°C
Junction Temperature	-55°C to +150°C
Lead Temperature (Soldering, 10 sec.).....	+300°C

*Currents are positive into, negative out of the specified terminal.
Pulsed is defined as a less than 10% duty cycle with a maximum duration of 500µs. Consult Packaging Section of Databook for thermal limitations and considerations of packages.*

CONNECTION DIAGRAM

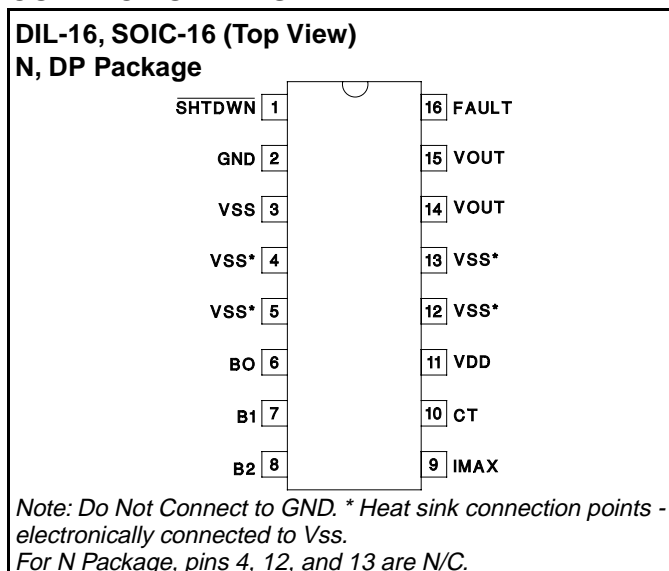

ELECTRICAL CHARACTERISTICS Unless otherwise stated, these specifications apply for TA = 0°C to 70°C for the UCC3920 and TA = -40°C to 85°C for the UCC2920, TA = TJ.

PARAMETER	TEST CONDITIONS	MIN	TYP	MAX	UNITS
Supply Section					
Voltage Input Range - VDD	Minimum < VDD < Maximum (Note 3)	3	5	5.5	V
Voltage Input Range - VSS	Minimum < VSS < Maximum	-13.2	-12	-3	V
VSS Supply Current			0.5	2	mA
VDD Supply Current			0.5	2	mA
Sleep Mode Current	Shutdown = 0.2V		0.5	2	mA
Shunt Clamp Voltage - (VDD - VSS)	I = 2mA to 10mA, Note 3	16.2	18	20	V
Output Section					
Voltage Drop	I _{OUT} = 1A		0.1	0.2	V
	I _{OUT} = 2A		0.2	0.4	V
	I _{OUT} = 3A		0.3	0.6	V
	I _{OUT} = 1A, VSS = -3V		0.1	0.2	V
	I _{OUT} = 2A, VSS = -3V		0.2	0.4	V
	I _{OUT} = 3A, VSS = -3V		0.3	0.6	V
Short Circuit Response	Note 1		20		µs
DAC Section					
Trip Current	Code = 000		0	20	µA
	Code = 001	0.1	0.25	0.45	A
	Code = 010	0.25	0.5	0.75	A
	Code = 011	0.75	1	1.25	A
	Code = 100	1.25	1.5	1.75	A
	Code = 101	1.7	2	2.3	A
	Code = 110	2.1	2.5	2.9	A
	Code = 111	2.5	3	3.5	A
Maximum Output Current	Code = 000, I _{MAX} = 0.4V		0	20	µA
	Code = 011, I _{MAX} = 0.4V	1	2	3	A
	Code = 101, I _{MAX} = 0.4V	2	3	4	A
	Code = 111, I _{MAX} = 0.4V	2.8	4	5.2	A
	I _{MAX} = 2.4V, All Codes	3	4	5.2	A

ELECTRICAL CHARACTERISTICS (cont.) Unless otherwise stated, these specifications apply for $T_A = 0^\circ\text{C}$ to 70°C for the UCC3920 and $T_A = -40^\circ\text{C}$ to 85°C for the UCC2920, $T_A = T_J$.

PARAMETER	TEST CONDITIONS	MIN	TYP	MAX	UNITS
Fault Section					
CT Charge Current	$V_{CT} = 1\text{V}$, Note 2	-50	-36	-22	μA
CT Discharge Current	$V_{CT} = 1\text{V}$, Note 2	0.36	0.6	1	μA
Output Duty Cycle	$V_{OUT} = 0\text{V}$	1	2	4	%
CT Fault Threshold	Note 2	1.25	1.5	1.75	V
CT Reset Threshold	Note 2	0.25	0.5	0.75	V
Shutdown Section					
Shutdown Threshold		1.1	1.5	1.9	V
Shutdown Hysteresis			50		mV
Open Drain Fault Output					
High Level Output Current				1	μA
Low Level Output Voltage	$I_{OUT} = 2\text{mA}$			0.4	V
	$I_{OUT} = 10\text{mA}$			0.9	V
Logic Input DC Characteristics					
Input Voltage High		2			V
Input Voltage Low				0.8	V
Input High Current	$V_{IH} = 2.4\text{V}$		3	10	μA
Input Low Current	$V_{IL} = 0.4\text{V}$			1	μA

Note 1: Guaranteed by design. Not 100% tested in production.

Note 2: Voltages measured with respect to VSS.

Note 3: An external resistor in series with VDD could be used to limit the current to 10mA if an input voltage higher than 15V is desired.

PIN DESCRIPTIONS

BO - B2: These pins provide a digital input to the DAC. They can be used to provide a digital soft start, adaptive current limiting, or be strapped for static applications.

CT: A capacitor connected to CT sets the maximum fault time. The maximum must be more than the time to charge external load capacitance. The maximum fault time is defined as $T_{FAULT} = 28 \cdot 10^3 \cdot CT$. Once the fault time is reached the output will shutdown for a time given by: $TSD = 1.67 \cdot 10^6 \cdot CT$, this equates to a 2% duty cycle.

FAULT: Open drain output which, pulls low, from VDD to GND, upon any condition which causes the output to open: Fault, Thermal Shutdown, or Shutdown.

GND: Reference return for VDD and VSS (VIN). This serves as the reference point for digital signals.

IMAX: When this pin is at a logic low the linear output

current will always be 1A above the programmed trip level, and with a logic high the linear current will always be a constant 4A for applications which require fast charging of load capacitance.

SHTDWN: When this pin is brought down low the IC is put into a sleep mode.

VDD: Positive input voltage to the circuit breaker. The input voltage range is 3V to 5.5V. If the total voltage excursion, $VDD - VSS$ could be 15V or greater, VDD should have an external limiting resistor in series with it.

VSS: The input voltage to the circuit breaker. The recommended voltage range is -3.3V to -15V .

VOUT: Output voltage for the circuit breaker. When switched the output voltage will be approximately $V_{IN} + 0.1\Omega \cdot I_{OUT}$.

TYPICAL APPLICATION

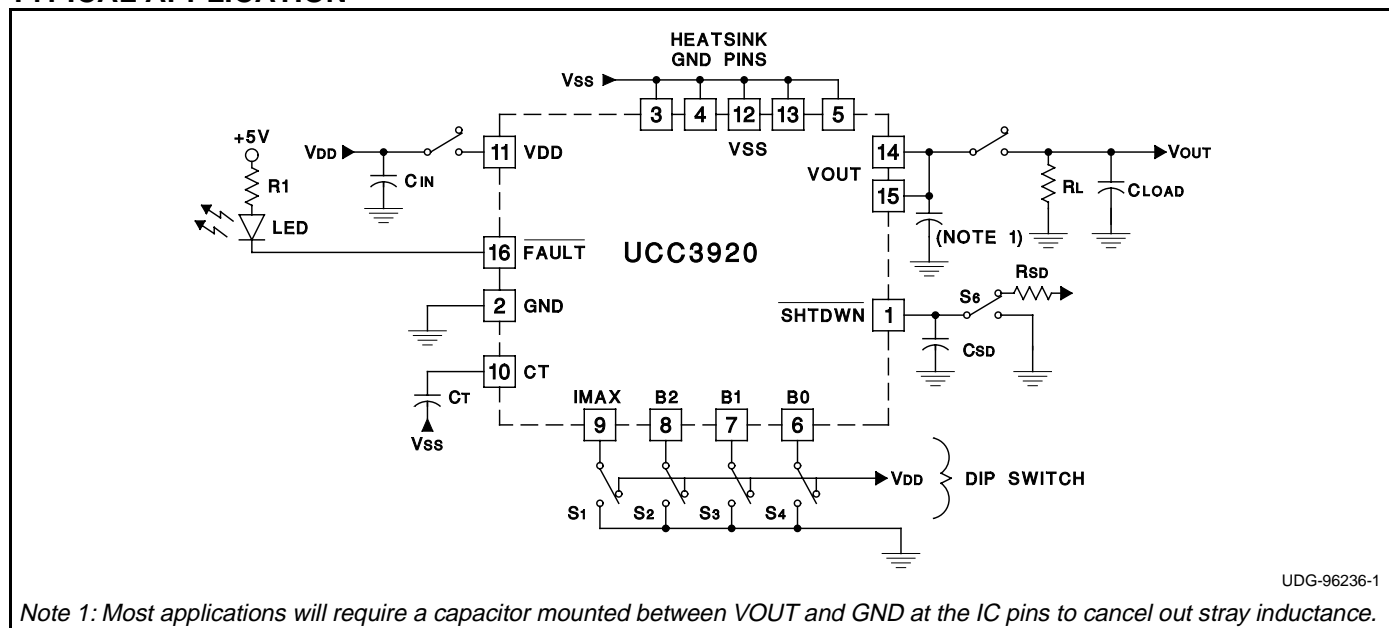

Note 1: Most applications will require a capacitor mounted between V_{OUT} and GND at the IC pins to cancel out stray inductance.

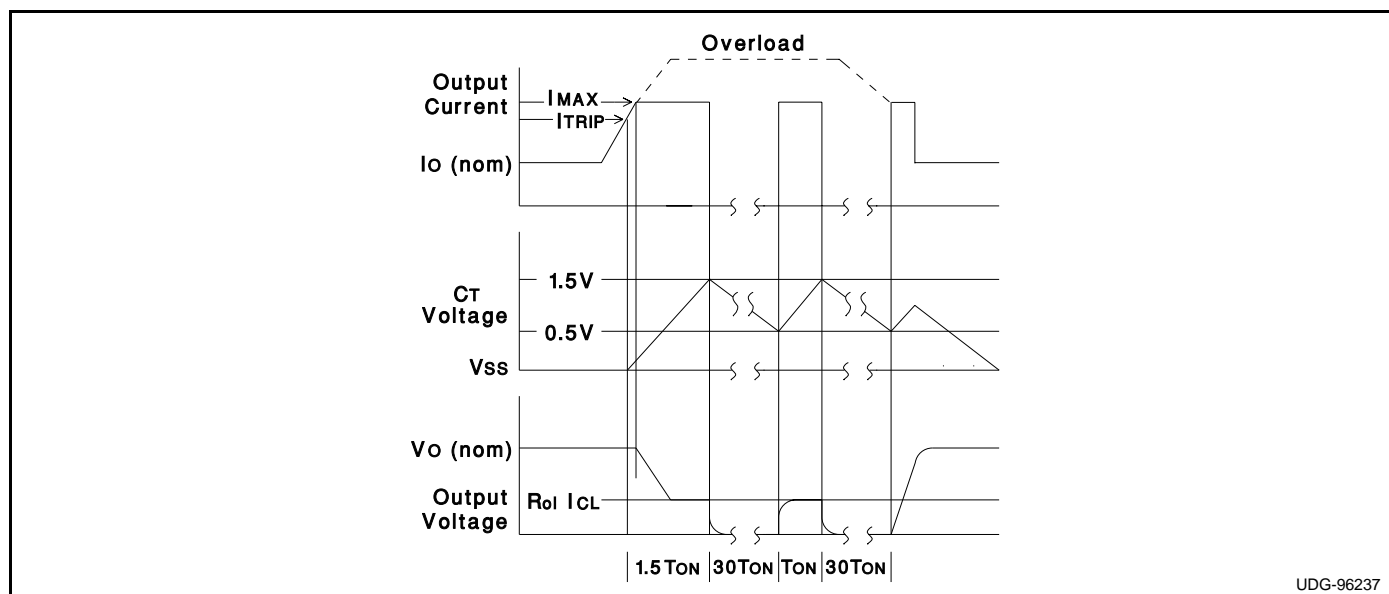

Estimating Maximum Load Capacitance

For power management applications, the rate at which the total output capacitance can be charged depends on the maximum output current available and the nature of the load. For a constant-current current-limited circuit, the output will rise if the load asks for less than the maximum available short-circuit current.

To guarantee duty-cycle recovery of the current-limited power manager from a short-circuited load condition, there is a maximum total output capacitance which can be charged for a given unit ON time (Fault time). The design value of ON or Fault time can be adjusted by changing the timing capacitor C_T.

For a worst-case constant-current load of value just less than the trip limit; C_{OUT(max)} can be estimated from:

$$C_{OUT(max)} \approx (I_{MAX} - I_{LOAD}) \cdot \left(\frac{28 \cdot 10^3 \cdot C_T}{V_{OUT}} \right)$$

Where V_{OUT} is the output voltage.

For a resistive load of value R_L, the value of C_{OUT(max)} can be estimated from:

$$C_{OUT(max)} \approx \left(\frac{28 \cdot 10^3 \cdot C_T}{R_L \cdot \ln \left[\frac{1}{1 - \frac{V_{OUT}}{I_{MAX} \cdot R_L}} \right]} \right)$$

UCC3920 ON TIME CONTROL CIRCUITRY

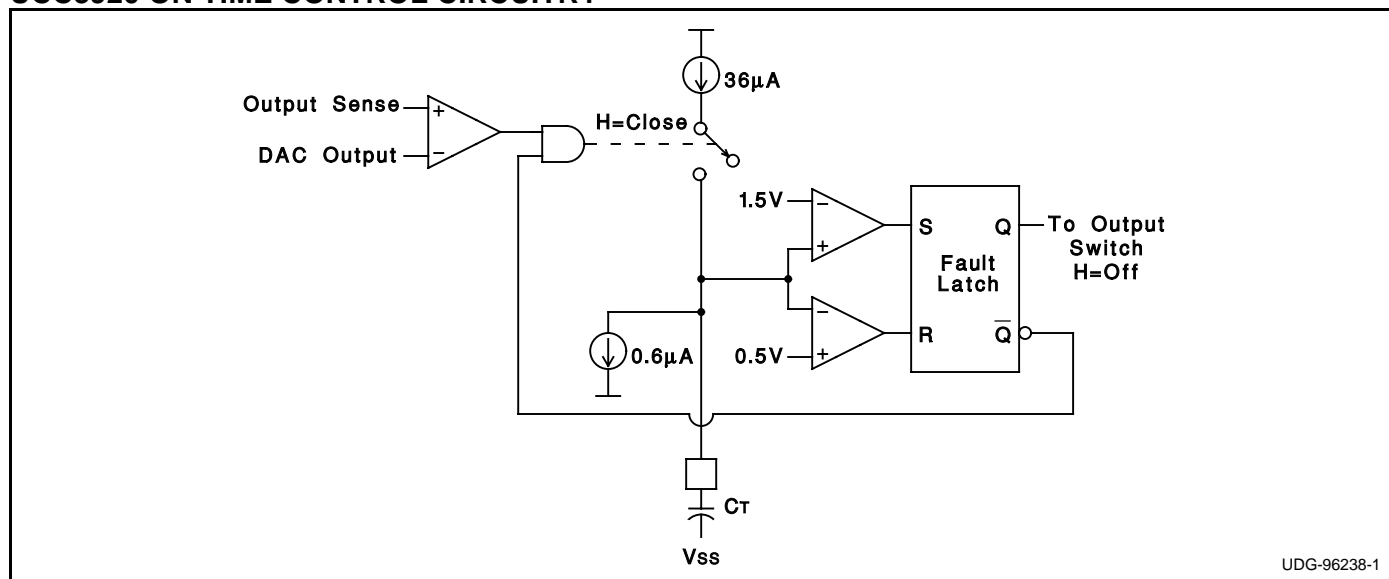

UDG-96238-1

The overcurrent comparator senses both the DAC output and a representation of the output current. When the output current exceeds the programmed level the timing capacitor C_T charges with $36\mu\text{A}$ of current. If the fault occurs for the time it takes for C_T to charge up to 1.5V , the fault latch is set and the output switch is opened. The output remains opened until C_T dis-

charges to 0.5V with a $0.6\mu\text{A}$ current source. Once the 0.5V is reached the output is enabled and will either appear as a switch, if the fault is removed, or a current source if the fault remains. If the over current condition is still present then C_T will begin charging, starting the cycle over, resulting in approximately a 2% duty cycle.

UCC3920 TYPICAL PERFORMANCE

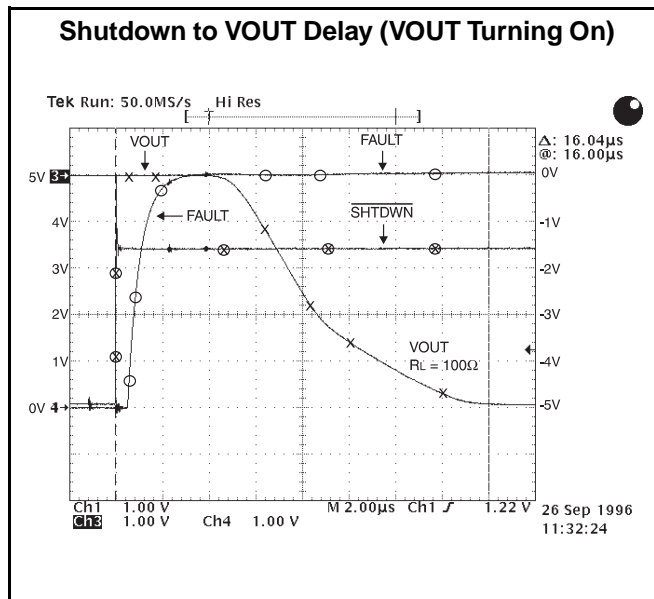
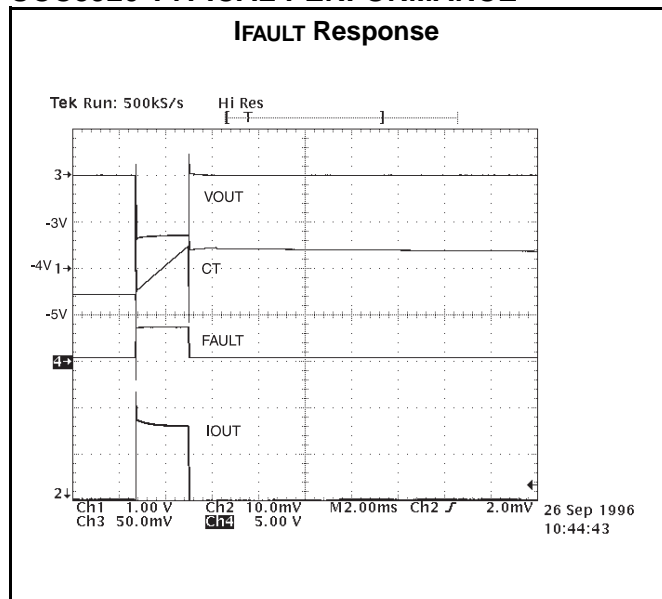

UCC3920 TYPICAL PERFORMANCE (cont.)

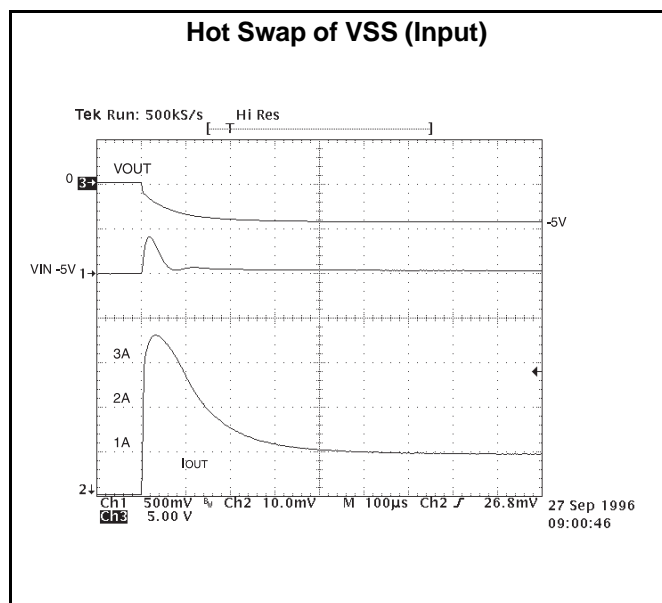
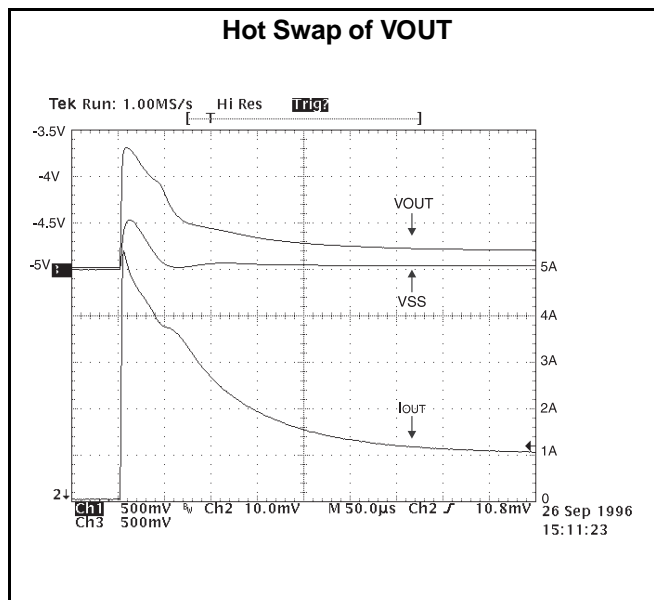
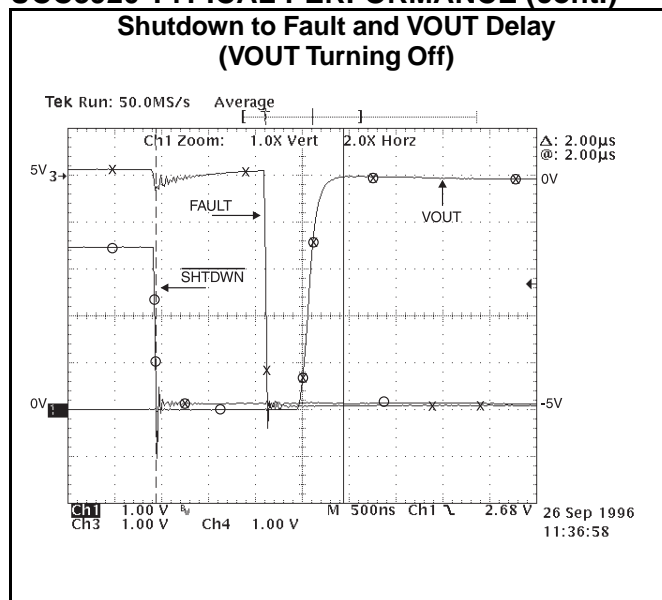

SAFETY RECOMMENDATION

Although the UCC3920 is designed to provide system protection for all fault conditions, all integrated circuits can ultimately fail short. For this reason, if the UCC3920 is intended for use in safety critical applications where UL or some other safety rating is required, a redundant safety device such as a fuse should be placed in series with the device. The UCC3920 will prevent the fuse from blowing for virtually all fault conditions, increasing system reliability and reducing maintenance cost, in addition to providing the hot swap benefits of the device.

IMPORTANT NOTICE

Texas Instruments and its subsidiaries (TI) reserve the right to make changes to their products or to discontinue any product or service without notice, and advise customers to obtain the latest version of relevant information to verify, before placing orders, that information being relied on is current and complete. All products are sold subject to the terms and conditions of sale supplied at the time of order acknowledgement, including those pertaining to warranty, patent infringement, and limitation of liability.

TI warrants performance of its semiconductor products to the specifications applicable at the time of sale in accordance with TI's standard warranty. Testing and other quality control techniques are utilized to the extent TI deems necessary to support this warranty. Specific testing of all parameters of each device is not necessarily performed, except those mandated by government requirements.

CERTAIN APPLICATIONS USING SEMICONDUCTOR PRODUCTS MAY INVOLVE POTENTIAL RISKS OF DEATH, PERSONAL INJURY, OR SEVERE PROPERTY OR ENVIRONMENTAL DAMAGE ("CRITICAL APPLICATIONS"). TI SEMICONDUCTOR PRODUCTS ARE NOT DESIGNED, AUTHORIZED, OR WARRANTED TO BE SUITABLE FOR USE IN LIFE-SUPPORT DEVICES OR SYSTEMS OR OTHER CRITICAL APPLICATIONS. INCLUSION OF TI PRODUCTS IN SUCH APPLICATIONS IS UNDERSTOOD TO BE FULLY AT THE CUSTOMER'S RISK.

In order to minimize risks associated with the customer's applications, adequate design and operating safeguards must be provided by the customer to minimize inherent or procedural hazards.

TI assumes no liability for applications assistance or customer product design. TI does not warrant or represent that any license, either express or implied, is granted under any patent right, copyright, mask work right, or other intellectual property right of TI covering or relating to any combination, machine, or process in which such semiconductor products or services might be or are used. TI's publication of information regarding any third party's products or services does not constitute TI's approval, warranty or endorsement thereof.