

8-BIT SINGLE-CHIP MICROCONTROLLER

- ★ The μ PD78P098A is a member of the μ PD78098 subseries of the 78K/0 series products, in which the on-chip mask ROM of the μ PD78098A is replaced with one-time PROM.

Because a program can be written by the user, the μ PD78P098A is ideal for evaluation of a system under development, small-scale production of a variety of systems, and early start of production of a system.

The functions are explained in detail in the following manuals. Be sure to read these manuals when designing your system.

- ★ μ PD78098 Subseries User's Manual : IEU-1381
78K/0 Series User's Manual - Instruction: U12326E

FEATURES

- Pin-compatible with mask ROM model (except V_{PP} pin)
- Internal PROM: 60K bytes^{Note 1}
- Internal high-speed RAM : 1024 bytes
- Buffer RAM : 32 bytes
- Internal expansion RAM : 2048 bytes^{Note 2}
- Operating voltage same as mask ROM model (V_{DD} = 2.7 to 5.5 V)
- Supports QTOP™ microcontroller

- Notes**
1. The internal PROM capacity can be changed by using the memory size select register(IMS).
 2. Internal expansion RAM capacity can be changed by using the internal expansion RAM size select register(IXS).

Remark "QTOP microcontroller" is a generic name for one-time PROM-containing microcontrollers totally supported by NEC's writing service (writing, marking, screening, and inspection).

The μ PD78P098A differs from the mask ROM model in the following points:

- The memory can be mapped in the same manner as the mask ROM model by using the memory size select register(IMS) and internal expansion RAM size select register(IXS).
- The P60 through P63 pins are not provided with pull-up resistors.

The information in this document is subject to change without notice. Before using this document, please confirm that this is the latest version.
Not all devices/types available in every country. Please check with local NEC representative for availability and additional information.

ORDERING INFORMATION

	Part Number	Package
★	μ PD78P098AGC-8BT	80-pin plastic QFP (14 × 14)

★ 78K/0 SERIES LINEUP

The products in the 78K/0 Series are listed below. The names enclosed in boxes are subseries names.

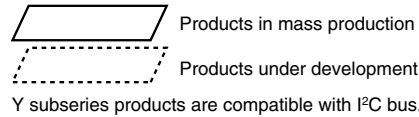

Pin Count	Subseries Name	Description
Control		
100-pin	μPD78075B	EMI-noise reduced version of the μPD78078
100-pin	μPD78078	μPD78054 with added timer and enhanced external interface
100-pin	μPD78070A	ROM-less version of the μPD78078
100-pin	μPD780018AY	μPD78078Y with enhanced serial I/O and limited function
80-pin	μPD780058	μPD78054 with enhanced serial I/O
80-pin	μPD78058F	EMI-noise reduced version of the μPD78054
80-pin	μPD78054	μPD78018F with enhanced UART and D/A converter and enhanced I/O
80-pin	μPD780065	RAM capacity of the μPD780024A increased.
64-pin	μPD780078	μPD780034A with added timer and enhanced serial I/O
64-pin	μPD780034A	μPD780024A with enhanced A/D converter
64-pin	μPD780024A	μPD78018F with enhanced serial I/O
64-pin	μPD78014H	EMI-noise reduced version of the μPD78018F
64-pin	μPD78018F	Basic subseries for control
42-/44-pin	μPD78083	On-chip UART, capable of operating at low voltage (1.8 V)
Inverter control		
64-pin	μPD780988	On-chip inverter controller and UART. EMI-noise reduced.
VFD drive		
100-pin	μPD780208	μPD78044F with enhanced I/O and VFD C/D. Display output total: 53
80-pin	μPD780232	For panel control. On-chip VFD and C/D. Display output total: 53
80-pin	μPD78044H	μPD78044F with added N-ch open-drain I/O. Display output total: 34
80-pin	μPD78044F	Basic subseries for VFD drive. Display output total: 34
LCD drive		
120-pin	μPD780338	μPD780308 with enhanced display function and timer. Segment signal output: 40 pins max.
120-pin	μPD780328	μPD780308 with enhanced display function and timer. Segment signal output: 32 pins max.
120-pin	μPD780318	μPD780308 with enhanced display function and timer. Segment signal output: 24 pins max.
100-pin	μPD780308	μPD78064 with enhanced SIO, and increased ROM, RAM capacity
100-pin	μPD78064B	EMI-noise reduced version of the μPD78064
100-pin	μPD78064	Basic subseries for LCD drive, on-chip UART
Bus interface supported		
100-pin	μPD780948	On-chip D-CAN controller
80-pin	μPD78098B	μPD78054 with added IEBus™ controller.
80-pin	μPD780702Y	On-chip IEBus controller
80-pin	μPD780703Y	On-chip D-CAN controller
80-pin	μPD780833Y	On-chip controller compliant with J1850 (Class 2)
64-pin	μPD780816	Specialized for D-CAN controller function
Meter control		
100-pin	μPD780958	For industrial meter control
80-pin	μPD780852	On-chip automobile meter controller/driver
80-pin	μPD780828B	For automobile meter driver. On-chip D-CAN controller

Remark VFD (Vacuum Fluorescent Display) is referred to as FIP™ (Fluorescent Indicator Panel) in some documents, but the functions of the two are the same.

The major functional differences among the subseries are shown below.

Function Subseries Name		ROM Capacity (Bytes)	Timer				8-Bit A/D	10-Bit A/D	8-Bit D/A	Serial Interface	I/O	V _{DD} MIN. Value	External Expansion				
			8-Bit	16-Bit	Watch	WDT											
Control	μPD78075B	32 K to 40 K	4 ch	1 ch	1 ch	1 ch	8 ch	-	2 ch	3 ch (UART: 1 ch)	88	1.8 V	√				
	μPD78078	48 K to 60 K									61	2.7 V					
	μPD78070A	-															
	μPD780058	24 K to 60 K	2 ch							3 ch (time-division UART: 1 ch)	68	1.8 V					
	μPD78058F	48 K to 60 K									69	2.7 V					
	μPD78054	16 K to 60 K										2.0 V					
	μPD780065	40 K to 48 K										2.7 V					
	μPD780078	48 K to 60 K									2 ch	-		8 ch	3 ch (UART: 2 ch)	52	1.8 V
	μPD780034A	8 K to 32 K									1 ch				3 ch (UART: 1 ch)	51	
	μPD780024A					8 ch	-										
	μPD78014H								2 ch	53							
	μPD78018F	8 K to 60 K															
μPD78083	8 K to 16 K		-	-				1 ch (UART: 1 ch)	33		-						
Inverter control	μPD780988	16 K to 60 K	3 ch	Note	-	1 ch	-	8 ch	-	3 ch (UART: 2 ch)	47	4.0 V	√				
VFD drive	μPD780208	32 K to 60 K	2 ch	1 ch	1 ch	1 ch	8 ch	-	-	2 ch	74	2.7 V	-				
	μPD780232	16 K to 24 K	3 ch	-	-		4 ch				40	4.5 V					
	μPD78044H	32 K to 48 K	2 ch	1 ch	1 ch		8 ch			1 ch	68	2.7 V					
	μPD78044F	16 K to 40 K								2 ch							
LCD drive	μPD780338	48 K to 60 K	3 ch	2 ch	1 ch	1 ch	-	10 ch	1 ch	2 ch (UART: 1 ch)	54	1.8 V	-				
	μPD780328										62						
	μPD780318										70						
	μPD780308	48 K to 60 K	2 ch	1 ch		8 ch	-	-	3 ch (time-division UART: 1 ch)	57	2.0 V						
	μPD78064B	32 K							2 ch (UART: 1 ch)								
	μPD78064	16 K to 32 K															
Bus interface supported	μPD780948	60 K	2 ch	2 ch	1 ch	1 ch	8 ch	-	-	3 ch (UART: 1 ch)	79	4.0 V	√				
	μPD78098B	40 K to 60 K		1 ch							2 ch	69	2.7 V	-			
	μPD780816	32 K to 64 K		2 ch							12 ch	-	2 ch (UART: 1 ch)	46	4.0 V		
Meter control	μPD780958	48 K to 60 K	4 ch	2 ch	-	1 ch	-	-	-	2 ch (UART: 1 ch)	69	2.2 V	-				
Dash board control	μPD780852	32 K to 40 K	3 ch	1 ch	1 ch	1 ch	5 ch	-	-	3 ch (UART: 1 ch)	56	4.0 V	-				
	μPD780828B	32 K to 60 K								2 ch (UART: 1 ch)	59						

Note 16-bit timer: 2 channels
10-bit timer: 1 channel

Functional Outline

Item	Function								
Internal memory	<ul style="list-style-type: none"> • PROM : 60K bytes^{Note 1} • RAM <ul style="list-style-type: none"> Internal high-speed RAM : 1024 bytes Buffer RAM : 32 bytes Internal expansion RAM : 2048 bytes^{Note 2} 								
Memory space	64K bytes								
General-purpose register	8 bits × 32 registers (8 bits × 8 registers × 4 banks)								
Instruction cycle	Variable instruction execution time								
	<table border="1" style="width: 100%; border-collapse: collapse;"> <tr> <td style="width: 20px;">With main system clock</td> <td>0.5 μs/1.0 μs/2.0 μs/4.0 μs/8.0 μs/16.0 μs (at 6.0 MHz)</td> </tr> <tr> <td>With subsystem clock</td> <td>122 μs (at 32.768 kHz)</td> </tr> </table>	With main system clock	0.5 μs/1.0 μs/2.0 μs/4.0 μs/8.0 μs/16.0 μs (at 6.0 MHz)	With subsystem clock	122 μs (at 32.768 kHz)				
With main system clock	0.5 μs/1.0 μs/2.0 μs/4.0 μs/8.0 μs/16.0 μs (at 6.0 MHz)								
With subsystem clock	122 μs (at 32.768 kHz)								
Instruction set*	16-bit operation <ul style="list-style-type: none"> • Multiplication/division (8 bits × 8 bits, 16 bits ÷ 8 bits) • Bit manipulation (set, reset, test, Boolean operation) • BCD adjustment, etc. 								
I/O port	<table style="width: 100%;"> <tr> <td style="width: 50px;">Total</td> <td style="text-align: right;">: 69</td> </tr> <tr> <td>• CMOS input</td> <td style="text-align: right;">: 2</td> </tr> <tr> <td>• CMOS I/O</td> <td style="text-align: right;">: 63</td> </tr> <tr> <td>• N-ch open-drain I/O</td> <td style="text-align: right;">: 4</td> </tr> </table>	Total	: 69	• CMOS input	: 2	• CMOS I/O	: 63	• N-ch open-drain I/O	: 4
Total	: 69								
• CMOS input	: 2								
• CMOS I/O	: 63								
• N-ch open-drain I/O	: 4								
IEBus controller	Effective transmission rate: 3.9 kbps/17 kbps/26 kbps								
A/D converter	8-bit resolution × 8 channels								
D/A converter	8-bit resolution × 2 channels								
Serial interface	<ul style="list-style-type: none"> • 3-line/SBI/2-line mode selectable : 1 channel • 3-line mode (with function to automatically transfer/receive 32 bytes max.) : 1 channel • 3-line/UART mode selectable : 1 channel 								
Timer	<ul style="list-style-type: none"> • 16-bit timer/event counter : 1 channel • 8-bit timer/event counter : 2 channels • Watch timer : 1 channel • Watchdog timer : 1 channel 								
Timer output	3 (14-bit PWM output: 1)								
Clock output	15.6 kHz, 31.3 kHz, 62.5 kHz, 125 kHz, 250 kHz, 500 kHz, 1.0 MHz, 2.0 MHz, 4.0 MHz (with 6.0-MHz main system clock) 32.768 kHz (with 32.768-kHz subsystem clock)								
Buzzer output	977 Hz, 1.95 kHz, 3.9 kHz, 7.8 kHz (with 6.0-MHz main system clock)								

- Notes**
1. The internal PROM capacity can be changed by using the memory size select register (IMS).
 2. 0 or 2048 bytes can be selected by using the internal expansion RAM size select register (IXS).

Item		Function
Vector interrupt	Maskable interrupt	Internal: 14, external: 7
	Non-maskable interrupt	Internal: 1
	Software interrupt	1
Test input		Internal: 1, external: 1
Operating voltage		V _{DD} = 2.7 to 5.5 V
★ Package		• 80-pin plastic QFP (14 × 14)

PIN CONFIGURATION (Top View)

(1) Normal operation mode

- 80-pin plastic QFP (14 × 14)

★

μPD78P098AGC-8BT

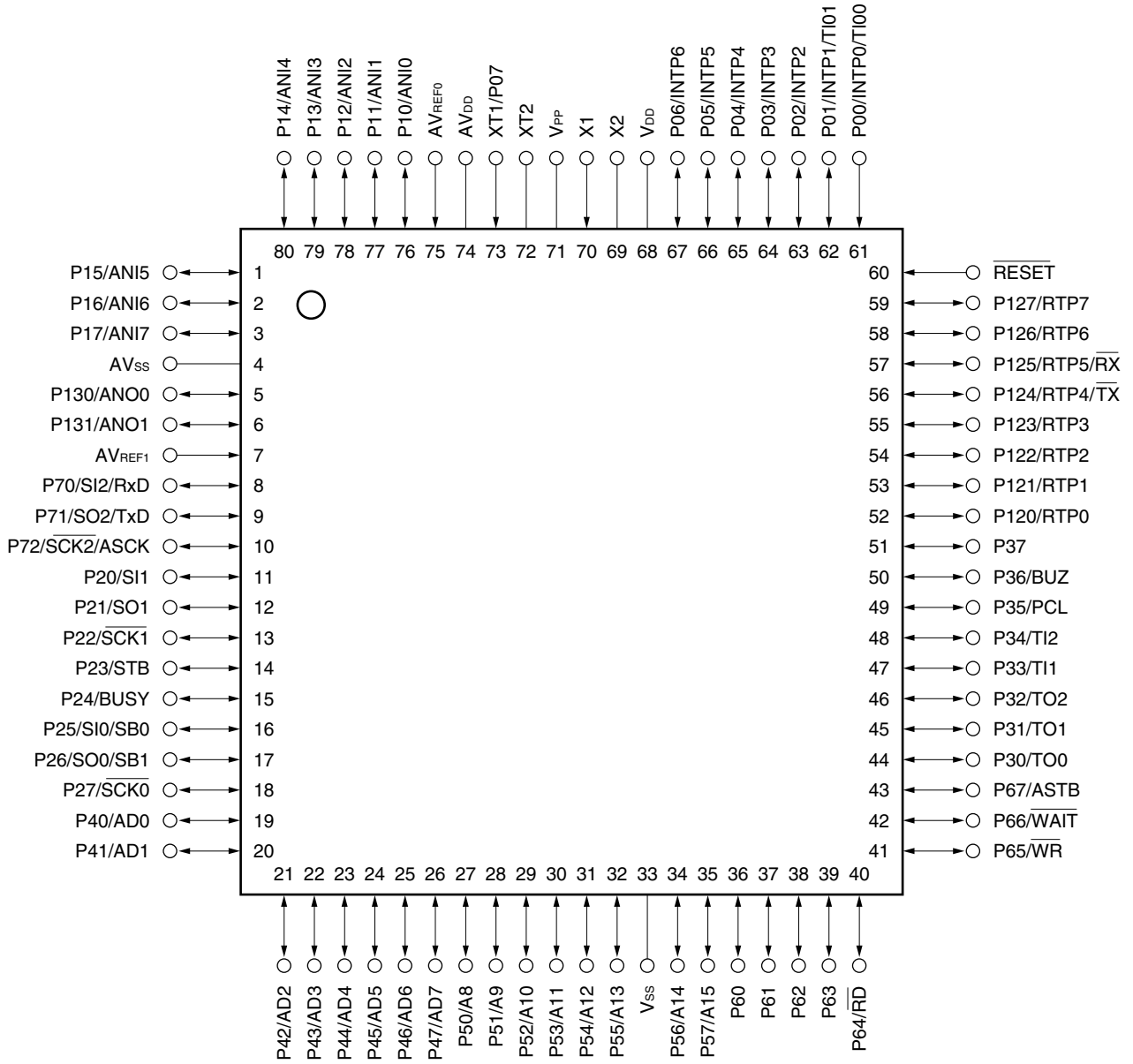

- Cautions**
1. Directly connect the VPP pin to VSS.
 2. Connect the AVDD pin to VDD.
 3. Connect the AVSS pin to VSS.

P00-P07	: Port0	\overline{RX}	: Receive Data (IEBus Controller)
P10-P17	: Port1	\overline{TX}	: Transmit Data (IEBus Controller)
P20-P27	: Port2	PCL	: Programmable Clock
P30-P37	: Port3	BUZ	: Buzzer Clock
P40-P47	: Port4	STB	: Strobe
P50-P57	: Port5	BUSY	: Busy
P60-P67	: Port6	AD0-AD7	: Address/Data Bus
P70-P72	: Port7	A8-A15	: Address Bus
P120-P127	: Port12	\overline{RD}	: Read Strobe
P130, P131	: Port13	\overline{WR}	: Write Strobe
RTP0-RTP7	: Real-Time Output Port	\overline{WAIT}	: Wait
INTP0-INTP6	: Interrupt from Peripherals	ASTB	: Address Strobe
TI00, TI01	: Timer Input	X1, X2	: Crystal (Main System Clock)
TI1, TI2	: Timer Input	XT1, XT2	: Crystal (Subsystem Clock)
TO0-TO2	: Timer Output	\overline{RESET}	: Reset
SB0, SB1	: Serial Bus	ANI0-ANI7	: Analog Input
SI0-SI2	: Serial Input	ANO0, ANO1	: Analog Output
SO0-SO2	: Serial Output	AV _{DD}	: Analog Power Supply
$\overline{SCK0-SCK2}$: Serial Clock	AV _{SS}	: Analog Ground
RxD	: Receive Data (UART)	AV _{REF0, 1}	: Analog Reference Voltage
TxD	: Transmit Data (UART)	V _{DD}	: Power Supply
ASCK	: Asynchronous Serial Clock	V _{PP}	: Programming Power Supply
		V _{SS}	: Ground

(2) PROM programming mode

- 80-pin plastic QFP (14 × 14)
μPD78P098AGC-8BT

★

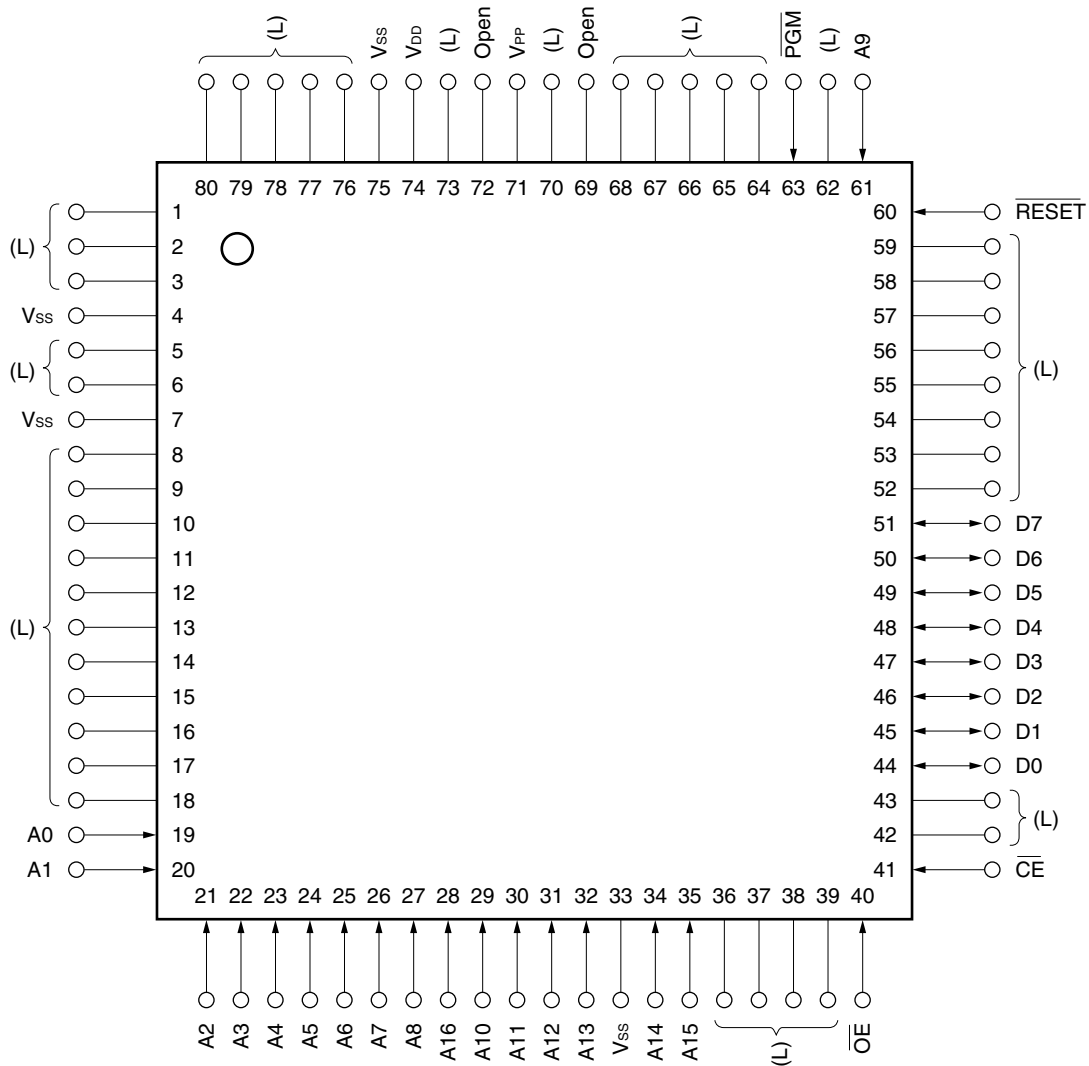

- Cautions**
1. (L) : Individually connect these pins to Vss via a pull-down resistor.
 2. Vss : Connect this pin to ground.
 3. $\overline{\text{RESET}}$: Keep this pin to the low level.
 4. Open : Connect nothing to these pins.

A0-A16	: Address Bus	$\overline{\text{RESET}}$: Reset
D0-D7	: Data Bus	V _{DD}	: Power Supply
$\overline{\text{CE}}$: Chip Enable	V _{PP}	: Programming Power Supply
$\overline{\text{OE}}$: Output Enable	V _{SS}	: Ground
$\overline{\text{PGM}}$: program		

BLOCK DIAGRAM

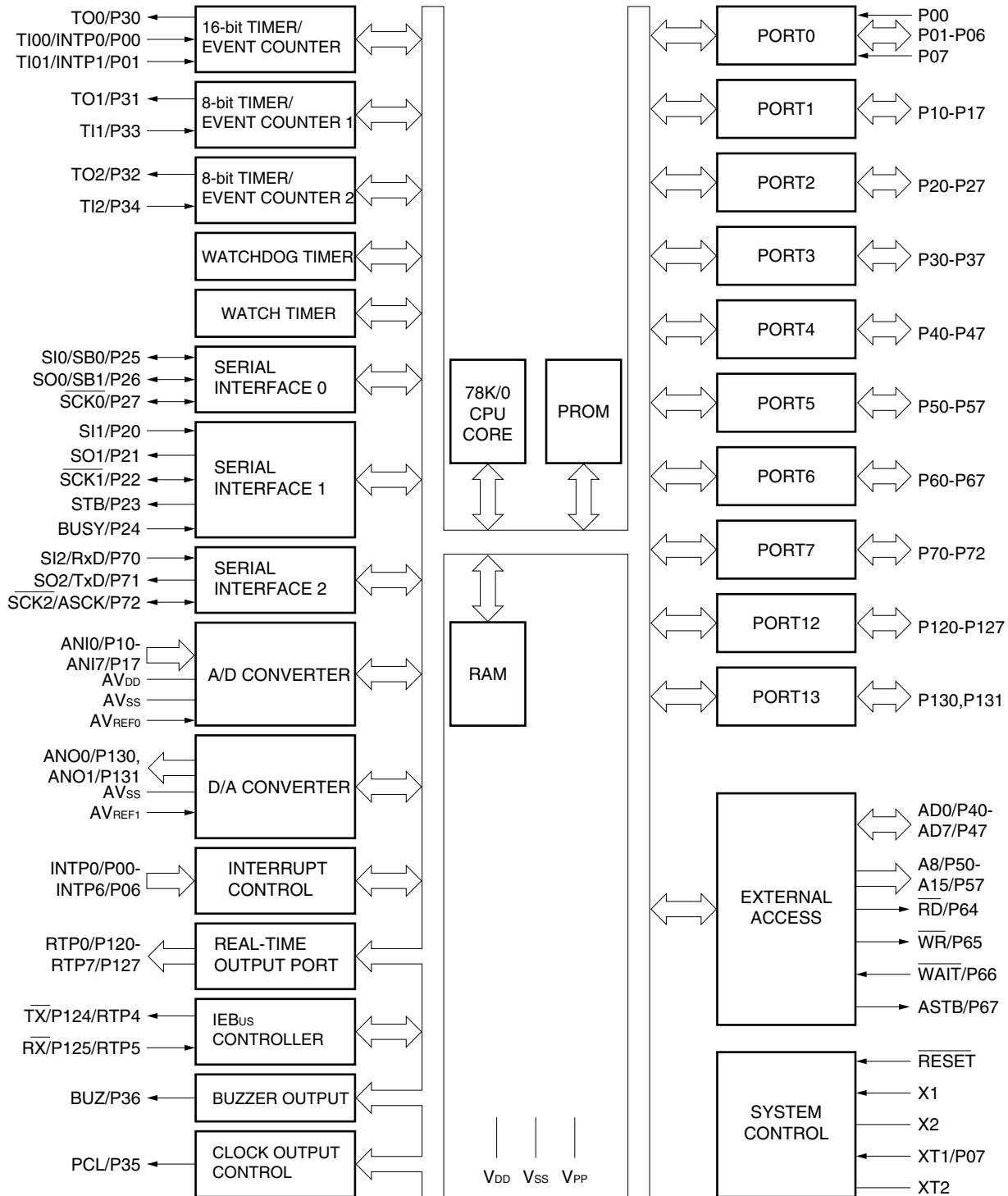

TABLE OF CONTENTS

1. DIFFERENCES BETWEEN μPD78P098A AND MASK ROM MODEL 12

2. PIN FUNCTIONS 13

 2.1 Pins in Normal Operation Mode 13

 2.2 Pins in PROM Programming Mode 16

 2.3 Pin I/O Circuits and Handling of Unused Pins 17

3. MEMORY SIZE SELECT REGISTER (IMS) 21

4. INTERNAL EXPANSION RAM SIZE SELECT REGISTER (IXS) 22

5. PROM PROGRAMMING 23

 5.1 Operation Modes 23

 5.2 PROM Writing Procedure 25

 5.3 PROM Read Procedure 29

6. SCREENING OF ONE-TIME PROM MODEL 30

7. ELECTRICAL SPECIFICATIONS 31

8. PACKAGE DRAWINGS 65

★ 9. RECOMMENDED SOLDERING CONDITIONS 66

APPENDIX A. DEVELOPMENT TOOLS 67

APPENDIX B. RELATED DOCUMENTS 71

1. DIFFERENCES BETWEEN μPD78P098A AND MASK ROM MODEL

- ★ The μPD78P098A is provided with a one-time PROM to which a program can be written only once. The functions of the μPD78P098A, except the PROM specification and the mask option of P60 through P63 pins, can be set to be the same as those of the mask ROM model by using the memory size select register and internal expansion RAM size select register.

Table 1-1 shows the differences between the μPD78P098A and mask ROM model.

Table 1-1. Differences between μPD78P098A and Mask ROM Model

Item	μPD78P098A	Mask ROM Model
IC pin	Not provided	Provided
V _{PP} pin	Provided	Not provided
Mask option of P60-P63 pins	Pull-up resistor not provided	Pull-up resistor can be provided by mask option

- Cautions**
1. The internal ROM capacity of the μPD78P098A can be changed by using the memory size select register. The internal PROM capacity is set to 60K bytes at $\overline{\text{RESET}}$.
 2. The internal expansion RAM capacity of the μPD78P098A can be changed by using the internal expansion RAM size select register. The internal expansion RAM capacity is set to 2K bytes at $\overline{\text{RESET}}$.

2. PIN FUNCTIONS

2.1 Pins in Normal Operation Mode

(1) Port pins (1/2)

Pin Name	I/O	Function		At Reset	Shared with:
P00	Input	Port 0.	Input only	Input	INTP0/TI00
P01	I/O	8-bit I/O port	Can be set in input or output mode in 1-bit units. When used as an input port, a pull-up resistor can be connected via software.	Input	INTP1/TI01
P02					INTP2
P03					INTP3
P04					INTP4
P05					INTP5
P06					INTP6
P07 ^{Note 1}	Input		Input only	Input	XT1
P10-P17	I/O	Port 1. 8-bit I/O port. Can be set in input or output mode in 1-bit units. When used as an input port, a pull-up resistor can be connected via software. ^{Note 2}		Input	ANI0-ANI7
P20	I/O	Port 2. 8-bit I/O port. Can be set in input or output mode in 1-bit units. When used as an input port, a pull-up resistor can be connected via software.		Input	SI1
P21					SO1
P22					SCK1
P23					STB
P24					BUSY
P25					SI0/SB0
P26					SO0/SB1
P27					SCK0
P30	I/O	Port 3. 8-bit I/O port. Can be set in input or output mode in 1-bit units. When used as an input port, a pull-up resistor can be connected via software.		Input	TO0
P31					TO1
P32					TO2
P33					TI1
P34					TI2
P35					PCL
P36					BUZ
P37					—

- Notes**
1. When using the P07/XT1 pin as an input port pin, set bit 6 (FRC) of the processor clock control register to 1 and do not use the feedback resistor of the subsystem clock oscillation circuit.
 2. When using the P10/ANI0 through P17/ANI7 pins as analog input pins of the A/D converter, the pull-up resistors are automatically disconnected.

(1) Port pins (2/2)

Pin Name	I/O	Function		At Reset	Shared with:	
P40-P47	I/O	Port 4. 8-bit I/O port. Can be set in input or output mode in 8-bit units. When used as an input port, a pull-up resistor can be connected via software. Test input flag (KRIF) is set to 1 at falling edge of this port.		Input	AD0-AD7	
P50-P57	I/O	Port 5. 8-bit I/O port. Can directly drive LED. Can be set in input or output mode in 1-bit units. When used as an input port, a pull-up resistor can be connected via software.		Input	A8-A15	
P60	I/O	Port 6.	N-ch open-drain I/O port. Can directly drive LED.	Input	-	
P61		8-bit I/O port.				
P62		Can be set in input or output mode in 1-bit units.	When used as an input port, a pull-up Input resistor can be connected via software.	Input		\overline{RD}
P63						\overline{WR}
P64						\overline{WAIT}
P65						ASTB
P66						
P67						
P70	I/O	Port 7.		Input	SI2/RxD	
P71		3-bit I/O port.			SO2/TxD	
P72		Can be set in input or output mode in 1-bit units. When used as an input port, a pull-up resistor can be connected via software.			$\overline{SCK2/ASCK}$	
P120-P123	I/O	Port 12.		Input	RTP0-RTP3	
P124		8-bit I/O port.			RTP4/ \overline{TX}	
P125		Can be set in input or output mode in 1-bit units.			RTP5/ \overline{RX}	
P126, P127		When used as an input port, a pull-up resistor can be connected via software.			RTP6, RTP7	
P130, P131	I/O	Port 13. 2-bit I/O port. Can be set in input or output mode in 1-bit units. When used as an input port, a pull-up resistor can be connected via software.		Input	ANO0, ANO1	

(2) Pins other than port pins (1/2)

Pin Name	I/O	Function	At Reset	Shared with:
INTP0	Input	External interrupt input whose valid edge can be specified (rising edge, falling edge, and both rising and falling edges).	Input	P00/TI00
INTP1				P01/TI01
INTP2				P02
INTP3				P03
INTP4				P04
INTP5				P05
INTP6				P06
SI0	Input	Serial data input to serial interface.	Input	P25/SB0
SI1				P20
SI2				P70/RxD
SO0	Output	Serial data output from serial interface.	Input	P26/SB1
SO1				P21
SO2				P71/TxD
SB0	I/O	Serial data input/output of serial interface.	Input	P25/SI0
SB1				P26/SO0
SCK0	I/O	Serial clock input/output of serial interface.	Input	P27
SCK1				P22
SCK2				P72/ASCK
STB	Output	Strobe signal output for serial interface automatic transmission/reception.	Input	P23
BUSY	Input	Busy input for serial interface automatic transmission/reception.	Input	P24
RxD	Input	Serial data input to asynchronous serial interface.	Input	P70/SI2
TxD	Output	Serial data output from asynchronous serial interface.	Input	P71/SO2
ASCK	Input	Serial clock input to asynchronous serial interface.	Input	P72/SCK2
TI00	Input	External count clock input to 16-bit timer (TM0).	Input	P00/INTP0
TI01		Capture trigger signal input to capture register (CR00).		P01/INTP1
TI1		External count clock input to 8-bit timer (TM1).		P33
TI2		External count clock input to 8-bit timer (TM2).		P34
TO0	Output	16-bit timer output (shared with 14-bit PWM output).	Input	P30
TO1		8-bit timer output (TM1).		P31
TO2		8-bit timer output (TM2)		P32
PCL	Output	Clock output (for trimming of main system clock and subsystem clock)	Input	P35
BUZ	Output	Buzzer output	Input	P36
RTP0-RTP3	Output	Real-time output port outputting data in synchronization with trigger.	Input	P120-P123
RTP4				P124/TX
RTP5				P125/RX
RTP6, RTP7				P126, P127
TX	Output	Data output for IEBus controller.	Input	P124/RTP4
RX	Input	Data input for IEBus controller.	Input	P125/RTP5

(2) Pins other than port pins (2/2)

Pin Name	I/O	Function	At Reset	Shared with:
AD0-AD7	I/O	Low-order address/data bus when external memory is connected.	Input	P40-P47
A8-A15	Output	High-order address bus when external memory is connected.	Input	P50-P57
\overline{RD}	Output	Strobe signal output for read operation on external memory.	Input	P64
\overline{WR}		Strobe signal output for write operation on external memory.	Input	P65
\overline{WAIT}	Input	Wait state insertion for external memory access.	Input	P66
ASTB	Output	Strobe output to externally latch address information output to ports 4 and 5 to access external memory.	Input	P67
ANI0-ANI7	Input	Analog input of A/D converter.	Input	P10-P17
ANO0, ANO1	Output	Analog output of D/A converter.	Input	P130, P131
AVREF0	Input	Reference voltage input of A/D converter.	–	–
AVREF1	Input	Reference voltage input of D/A converter.	–	–
AVDD	–	Analog power supply of A/D converter. Connected to VDD.	–	–
AVSS	–	Ground of A/D converter. Connected to VSS.	–	–
\overline{RESET}	Input	System reset input.	–	–
X1	Input	Crystal connection for main system clock oscillation.	–	–
X2	–		–	–
XT1	Input	Crystal connection for subsystem clock oscillation.	Input	P07
XT2	–		–	–
VDD	–	Positive power supply.	–	–
VPP	–	High-voltage application for program write/verify. Directly connected to VSS in normal operation mode.	–	–
VSS	–	Ground.	–	–

2.2 Pins in PROM Programming Mode

Pin Name	I/O	Function
\overline{RESET}	Input	PROM programming mode setting. When +5 V or +12.5 V is applied to the VPP pin, and low level is applied to the \overline{RESET} pin, PROM programming mode is set.
VPP	Input	PROM programming mode setting and high voltage application for program write/verify.
A0-A16	Input	Address bus.
D0-D7	I/O	Data bus.
\overline{CE}	Input	PROM enable input/program pulse input.
\overline{OE}	Input	Read strobe input to PROM.
PGM	Input	Program/program inhibit input in PROM programming mode.
VDD	–	Positive power supply.
VSS	–	Ground.

2.3 Pin I/O Circuits and Handling of Unused Pins

Table 2-1 shows the types of the I/O circuits for the various pins and handling of unused pins.
For the configuration of the various I/O circuits, refer to Figure 2-1.

Table 2-1. I/O Circuit Type of Each Pin (1/2)

Pin Name	I/O Circuit Type	I/O	Recommended Connection When Not Used	
P00/INTP0/TI00	2	Input	Connect to V _{SS} .	
P01/INTP1/TI01	8-A	I/O	Individually connect to V _{SS} via resistor.	
P02/INTP2				
P03/INTP3				
P04/INTP4				
P05/INTP5				
P06/INTP6				
P07/XT1	16	Input	Connect to V _{DD} or V _{SS} .	
P10/ANI0-P17/ANI7	11	I/O	Individually connect to V _{DD} or V _{SS} via resistor.	
P20/SI1	8-A			
P21/SO1	5-A			
P22/ $\overline{\text{SCK1}}$	8-A			
P23/STB	5-A			
P24/BUSY	8-A			
P25/SI0/SB0	10-A			
P26/SO0/SB1				
P27/ $\overline{\text{SCK0}}$				
P30/TO0	5-A			
P31/TO1				
P32/TO2				
P33/TI1	8-A			
P34/TI2				
P35/PCL	5-A			
P36/BUZ				
P37				
P40/AD0-P47/AD7	5-E			Individually connect to V _{DD} via resistor.
P50/A8-P57/A15	5-A			Individually connect to V _{DD} or V _{SS} via resistor.
P60-P63	13-D			Individually connect to V _{DD} via resistor.
P64/ $\overline{\text{RD}}$	5-A			Individually connect to V _{DD} or V _{SS} via resistor.
P65/ $\overline{\text{WR}}$				
P66/ $\overline{\text{WAIT}}$				
P67/ASTB				

Table 2-1. I/O Circuit Type of Each Pin (2/2)

Pin Name	I/O Circuit Type	I/O	Recommended Connection When Not Used
P70/SI2/RxD	8-A	I/O	Individually connect to V _{DD} or V _{SS} via resistor.
P71/SO2/TxD	5-A		
P72/SCK2/ASCK	8-A		
P120/RTP0-P123/RTP3	5-A		
P124/RTP4/TX			
P125/RTP5/RX			
P126/RTP6, P127/RTP7			
P130/AN00, P131/AN01			
RESET	2	Input	-
XT2	16	-	Open
AV _{REF0}	-		Connect to V _{SS} .
AV _{REF1}			Connect to V _{DD} .
AV _{DD}			
AV _{SS}			Connect to V _{SS} .
V _{PP}			Directly connect to V _{SS} .

Figure 2-1. I/O Circuits of Pins (1/2)

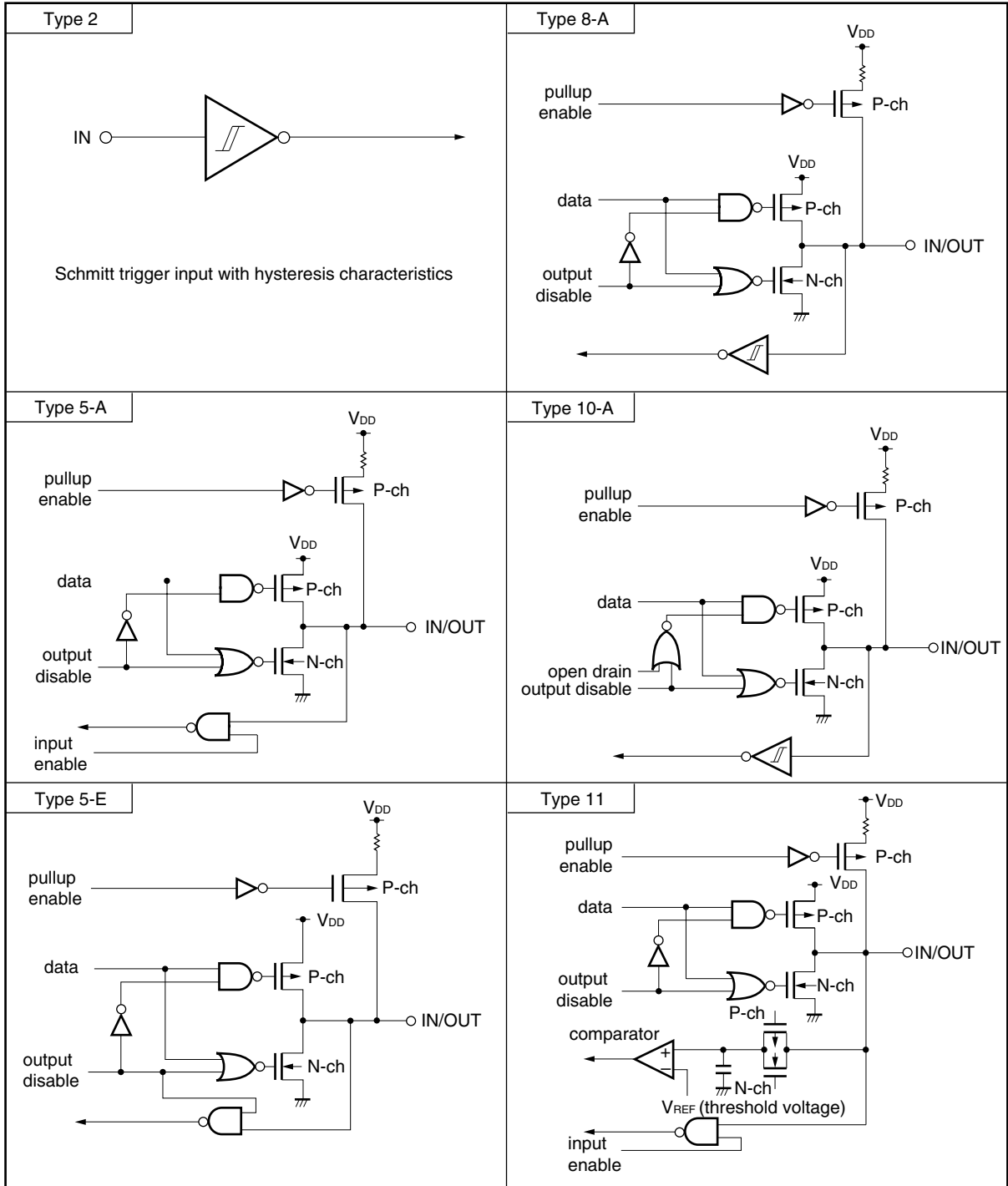
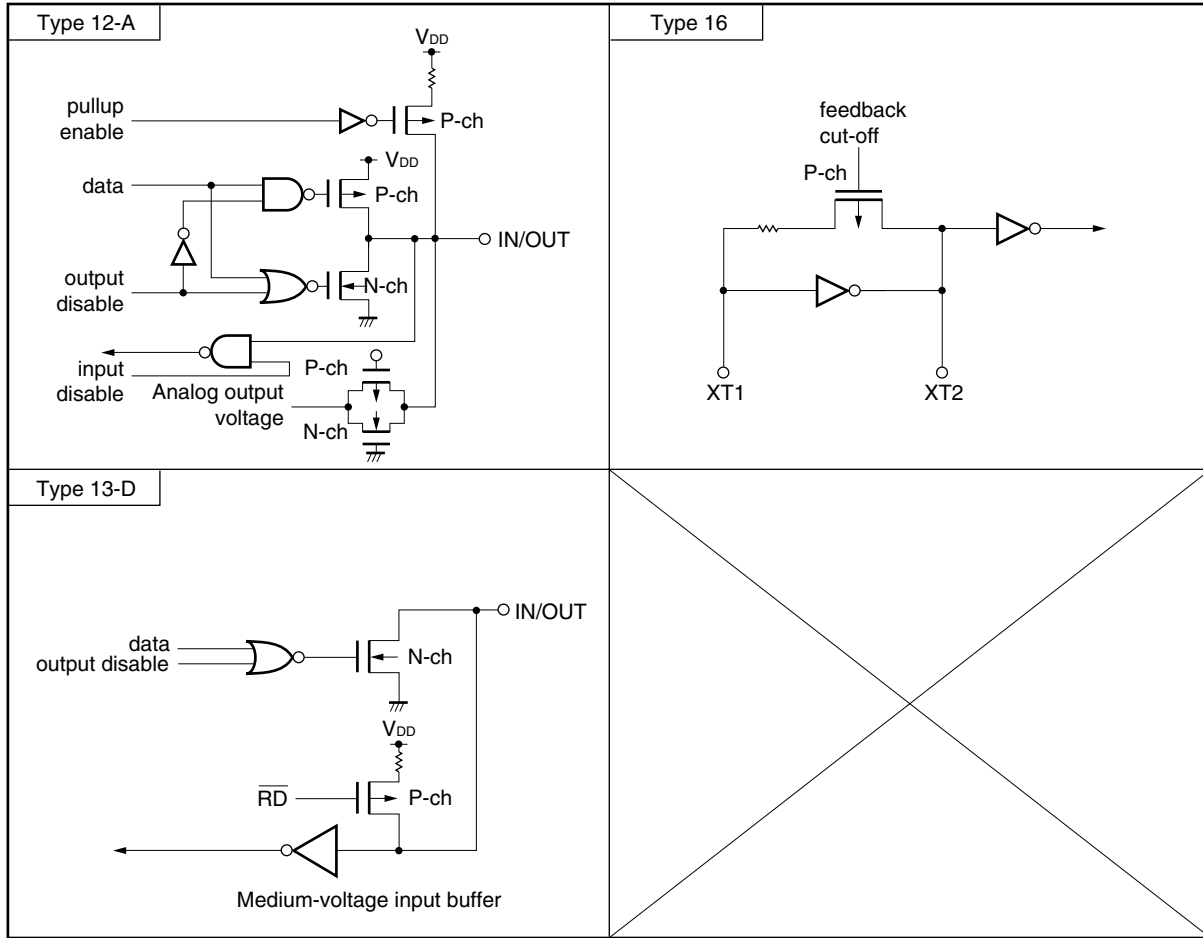

Figure 2-1. I/O Circuits of Pins (2/2)



3. MEMORY SIZE SELECT REGISTER (IMS)

This register specifies via software that part of the internal memory is not used. By using this register, the internal memory (ROM) of the μPD78P098A can be mapped in the same manner as a mask ROM model.

IMS is set by an 8-bit memory manipulation instruction.

The contents of this register are set to CFH at $\overline{\text{RESET}}$.

Figure 3-1. Format of the Memory Size Select Register

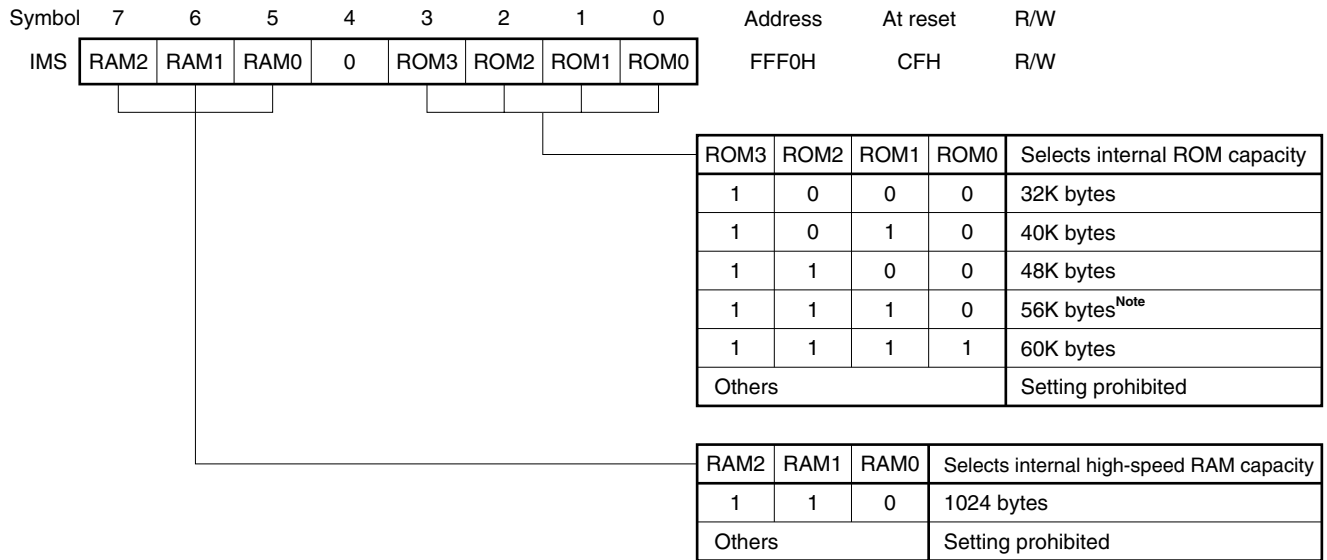

Note When using the external device expansion function, set the internal PROM capacity to 56K bytes or less.

Table 3-1 shows the value settings of IMS to map the memory of the μPD78P098A in the same manner as the respective mask ROM models.

Table 3-1. Value Settings of the Memory Size Select Register

Mask ROM Model	IMS Value Setting
μPD78094	C8H
μPD78095	CAH
μPD78096	CCH
μPD78098A	CFH

4. INTERNAL EXPANSION RAM SIZE SELECT REGISTER (IXS)

This register specifies the internal expansion RAM capacity via software. By using this register, the internal expansion RAM of the μPD78P098A can be mapped in the same manner as a mask ROM model.

IXS is set by an 8-bit memory manipulation instruction.

The contents of this register are set to 08H at RESET.

Figure 4-1. Format of Internal Expansion RAM Size Select Register

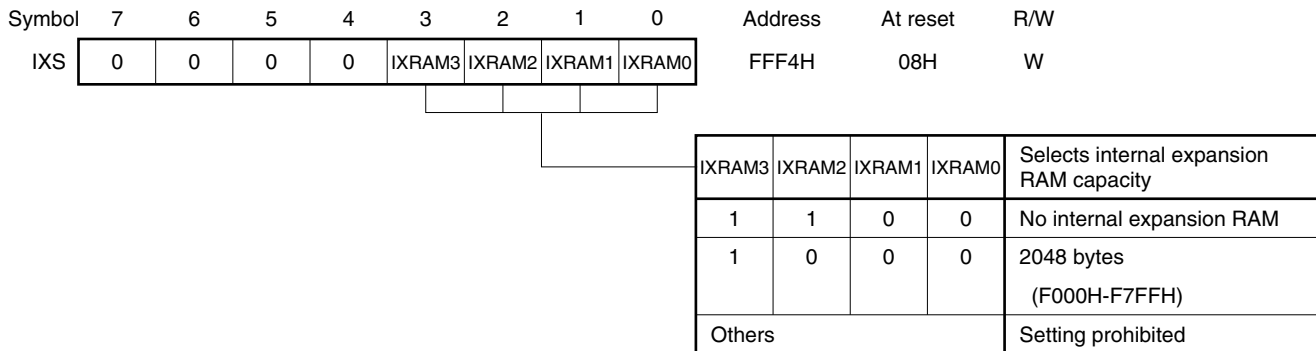

Table 4-1 shows the value settings of IXS to map the internal expansion RAM of the μPD78P098A in the same manner as the respective mask ROM models.

Table 4-1. Value Settings of Internal Expansion RAM Size Select Register

Mask ROM Model	IXS Value Setting
μPD78094	0CH ^{Note}
μPD78095	
μPD78096	
μPD78098A	08H

Note Even when a program for the μPD78P098A in which “MOV IXS, #0CH” is coded is executed on the μPD78094, 78095, or 78096, operation is unaffected.

5. PROM PROGRAMMING

The μPD78P098A is provided with a 60K-byte PROM as a program memory. When programming this memory, it must be set in the PROM programming mode by using the V_{PP} and $\overline{\text{RESET}}$ pins. For the handling of the unused pins, refer to (2) PROM programming mode in PIN CONFIGURATION (Top View).

Caution Write the program to addresses in the range 0000H through EFFFH (specify the last address as EFFFH). A program cannot be written with a PROM programmer that cannot specify write addresses.

5.1 Operation Modes

When +5 V or +12.5 V is applied to the V_{PP} pin and low level is applied to the $\overline{\text{RESET}}$ pin, the PROM programming mode is set. In this mode, the operation modes shown in Table 5-1 can be selected by using the $\overline{\text{CE}}$, $\overline{\text{OE}}$, and $\overline{\text{PGM}}$ pins.

The contents of the PROM can be read in the read mode.

Table 5-1. Operation Modes in PROM Programming Mode

Operation Mode	Pin	$\overline{\text{RESET}}$	V _{PP}	V _{DD}	$\overline{\text{CE}}$	$\overline{\text{OE}}$	$\overline{\text{PGM}}$	D0-D7
Page data latch	L		+12.5 V	+6.5 V	H	L	H	Data input
Page write					H	H	L	High impedance
Byte write					L	H	L	Data input
Program verify					L	L	H	Data output
Program inhibit					×	H	H	High impedance
					×	L	L	
Read			+5 V	+5 V	L	L	H	Data output
Output disable					L	H	×	High impedance
Standby					H	×	×	High impedance

Remark ×: L or H

(1) Read mode

This mode is set when both the \overline{CE} and \overline{OE} pins are made low.

(2) Output disable mode

When the \overline{OE} pin is made high, data output goes into a high-impedance state, and the output disable mode is set.

If two or more μ PD78P098As are connected to the data bus, therefore, data can be read from any one of the devices by controlling the \overline{OE} pin.

(3) Standby mode

The standby mode is set when the \overline{CE} pin is made high.

In this mode, data output goes into a high-impedance state regardless of the status of the \overline{OE} pin.

(4) Page data latch mode

The page data latch mode is set when the \overline{CE} and \overline{PGM} pins are made high and the \overline{OE} pin is made low at the beginning of the page write mode.

In this mode, data of 1 page and 4 bytes is latched to the internal address/data latch circuit.

(5) Page write mode

Page write is executed by applying a 0.1-ms program pulse (active low) to the \overline{PGM} pin with the \overline{CE} and \overline{OE} pins made high after addresses and data of 1 page and 4 bytes have been latched in the page data latch mode. After that, the program can be verified by making both the \overline{CE} and \overline{OE} pins low.

If the program cannot be written by one program pulse, writing and verifying are repeated X times ($X \leq 10$).

(6) Byte write mode

Byte write is executed by applying a 0.1-ms program pulse (active low) to the \overline{PGM} pin with the \overline{CE} pin made low and \overline{OE} pin high. The program is verified by later making the \overline{OE} pin low.

If the program cannot be written by one program pulse, writing and verifying are repeated X times ($X \leq 10$).

(7) Program verify mode

Program verify mode is set when the \overline{CE} and \overline{OE} pins are made low and the \overline{PGM} pin is made high.

After writing the program, check in this mode whether the program has been correctly written.

(8) Program inhibit mode

This mode is used to write a program to one of two or more μ PD78P098As with the \overline{OE} , V_{PP} , and D0 through D7 pins connected in parallel.

To write a program, the page write or byte write mode described above is used. At this time, the program is not written to those devices whose \overline{PGM} pin is made high.

5.2 PROM Writing Procedure

Figure 5-1. Page Program Mode Flowchart

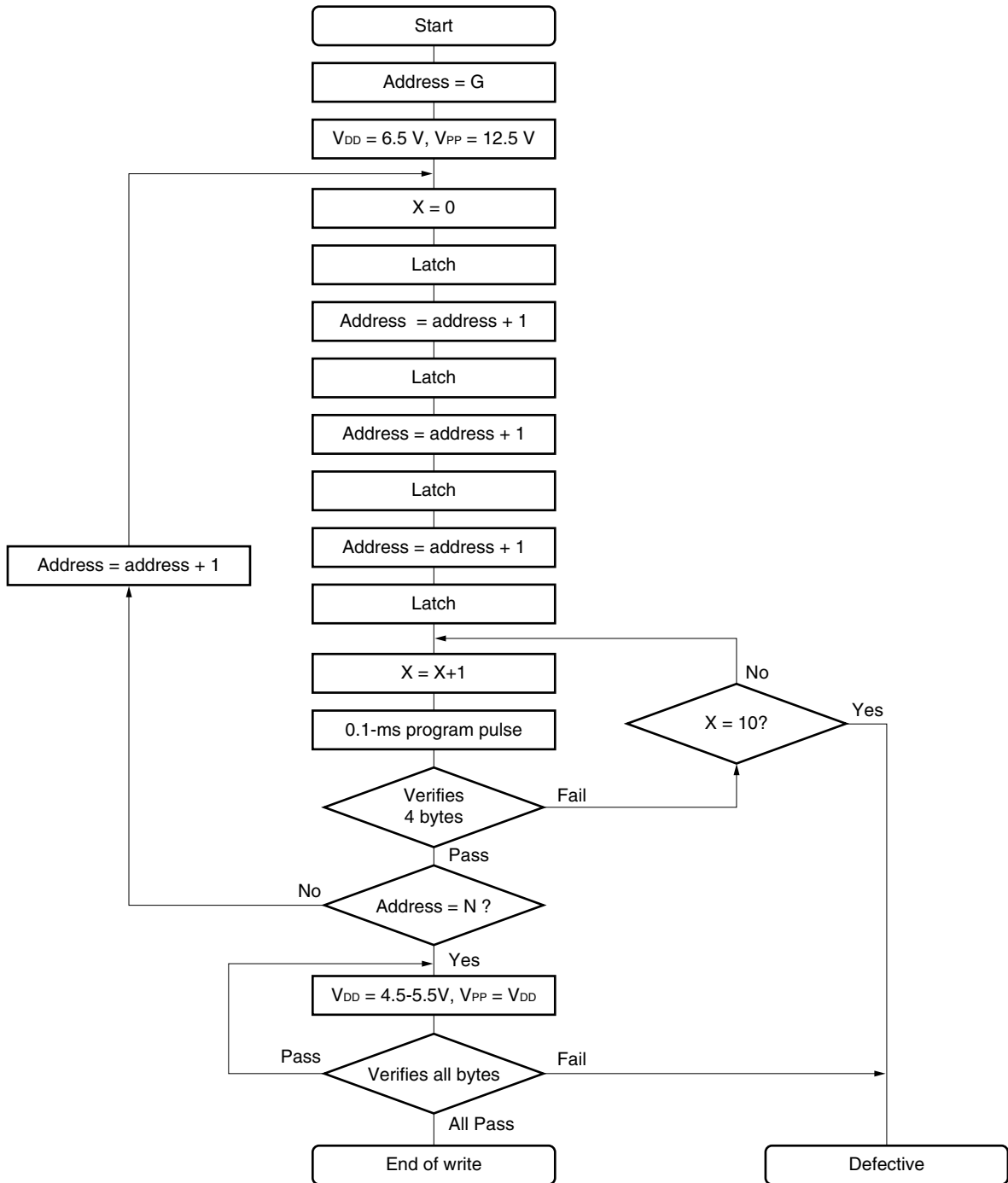

G = start address
 N = end address of program

Figure 5-2. Page Program Mode Timing

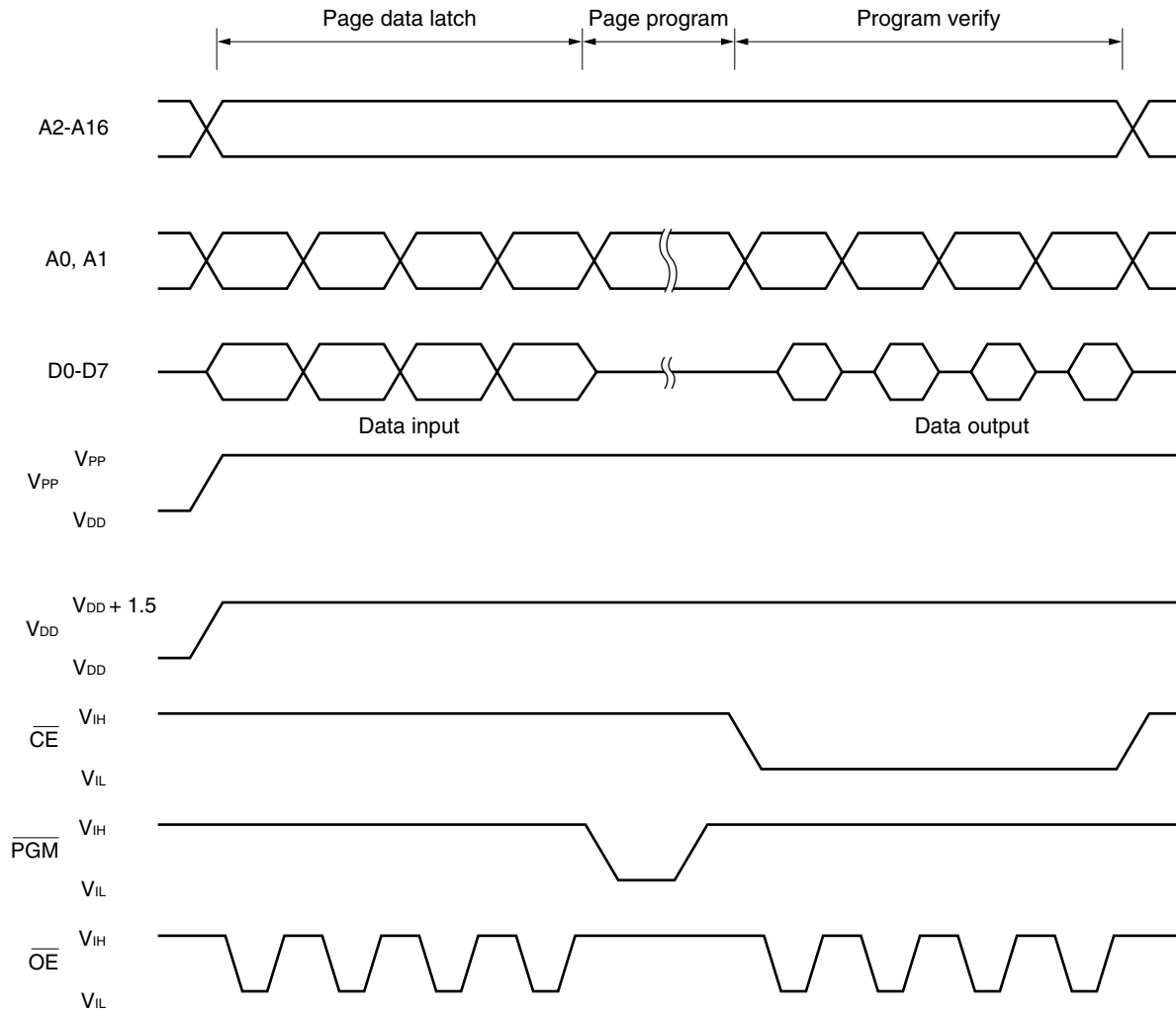
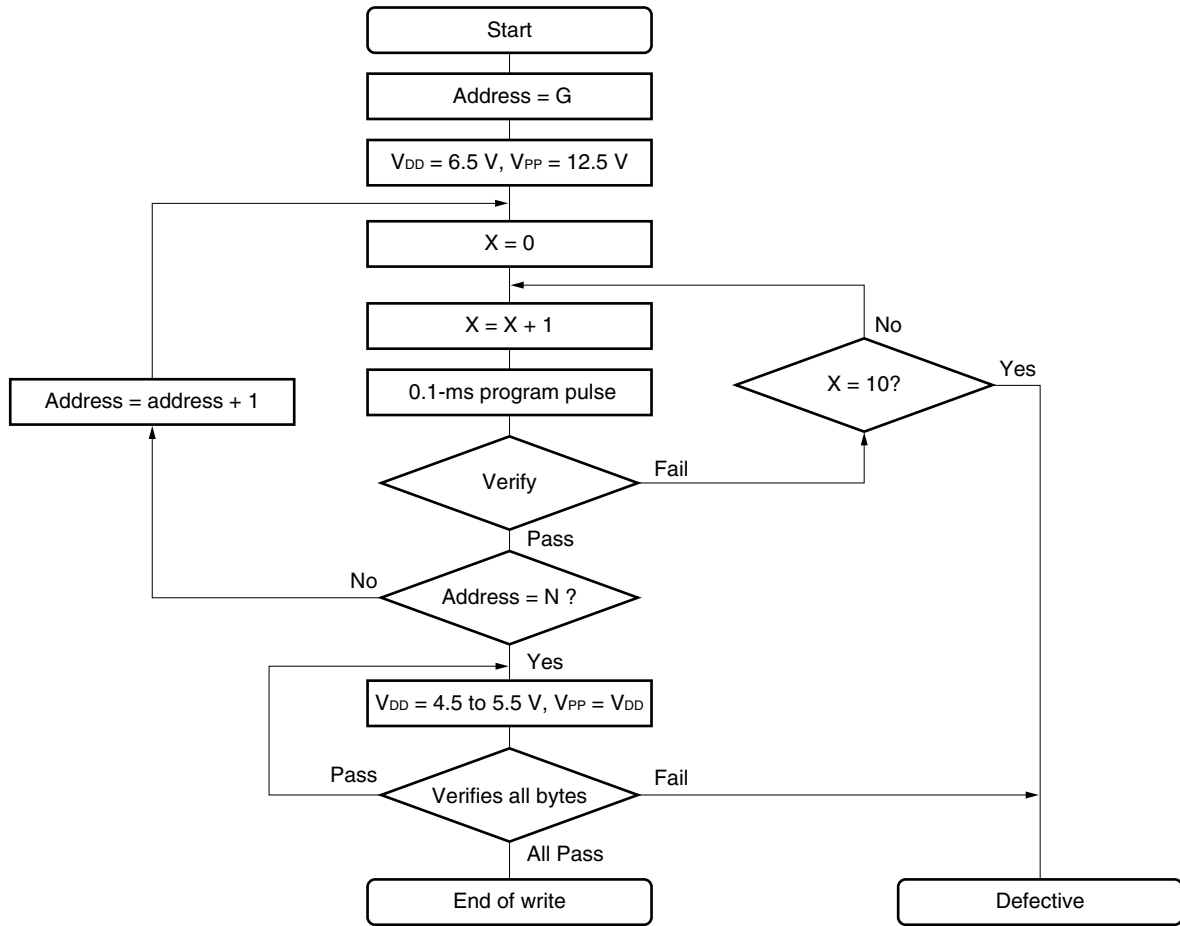
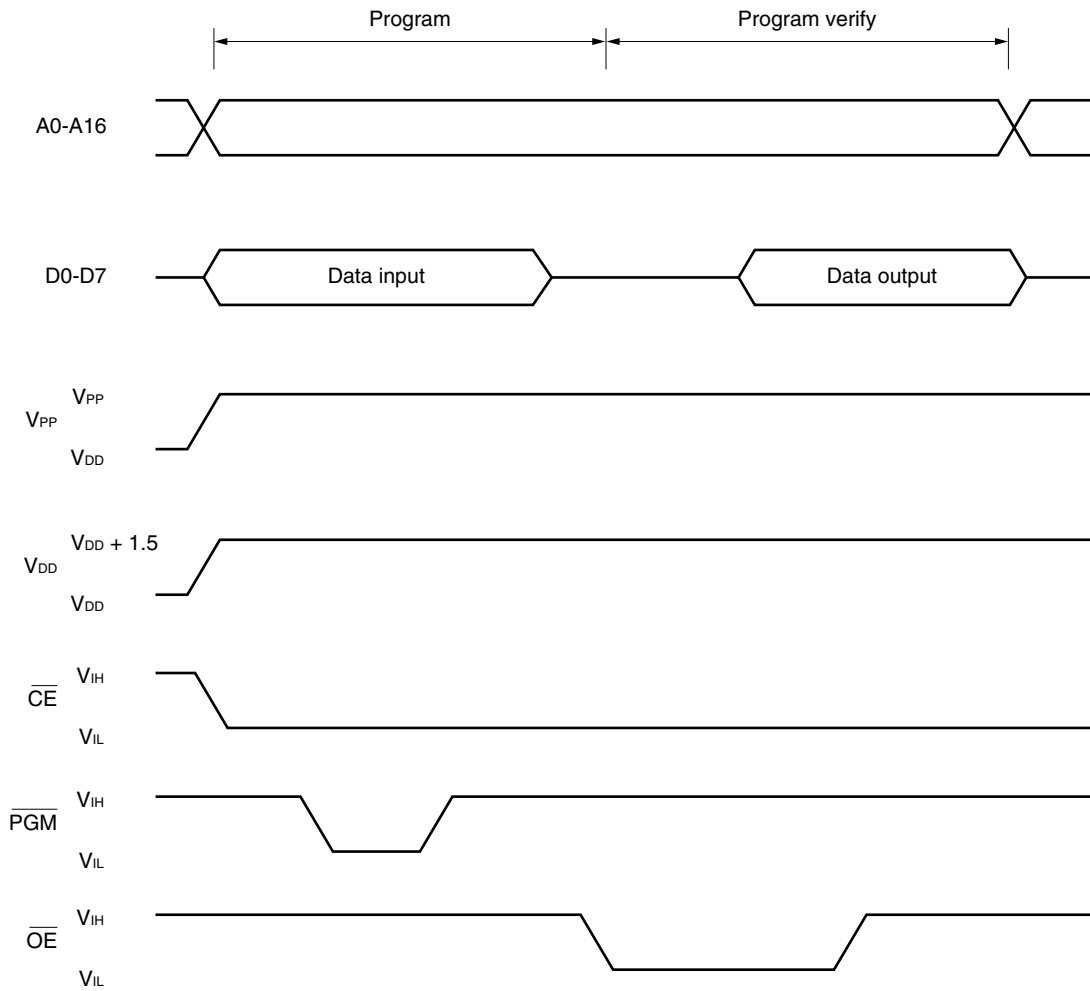

Figure 5-3. Byte Program Mode Flowchart



G = start address
 N = end address of program

Figure 5-4. Byte Program Mode Timing



- Cautions**
1. Apply V_{DD} before V_{PP} and turn off V_{DD} after V_{PP}.
 2. Keep V_{PP} from going above +13.5 V, including overshoot.
 3. If the device is inserted into or pulled out of the socket while +12.5 V is applied to V_{PP}, the reliability may be adversely affected.

5.3 PROM Read Procedure

The contents of the PROM can be read out to the external data bus (D0 through D7) in the following procedure:

- (1) Fix the $\overline{\text{RESET}}$ pin to the low level. Supply +5 V to the V_{PP} pin. Process the unused pins as described in **(2) PROM programming mode** in **PIN CONFIGURATION (Top View)**.
- (2) Supply +5 V to the V_{DD} and V_{PP} pins.
- (3) Input the address of the data to be read to the A0 through A16 pins.
- (4) The read mode is set.
- (5) Data is output to the D0 through D7 pins.

Figure 5-5 shows the timing of steps (2) through (5) above.

Figure 5-5. PROM Read Timing

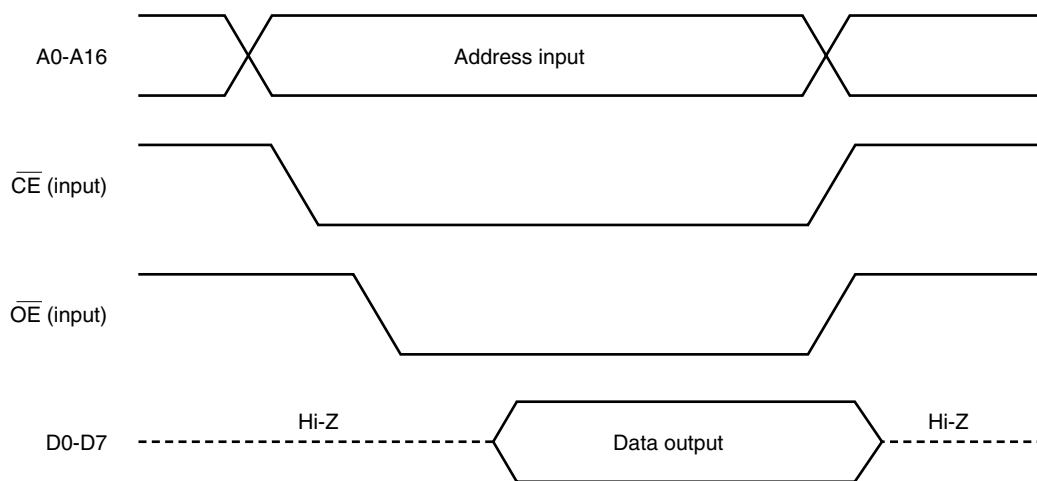

6. SCREENING OF ONE-TIME PROM MODEL

- ★ The one-time PROM model (μ PD78P098AGC-8BT) cannot be completely tested by NEC before shipment. It is recommended that screening be implemented to verify the PROM after data has been written to the PROM and the device has been stored under the following conditions:

Storage Temperature	Storage Time
125 °C	24 hours

NEC provides a writing, marking, screening, and verifying service for one-time PROMs, called QTOP microcontroller. This service for the μ PD78P098A is in preparation. For details, consult NEC.

7. ELECTRICAL SPECIFICATIONS

ABSOLUTE MAXIMUM RATINGS (T_A = 25°C)

Parameter	Symbol	Test Conditions		Rating	Unit		
Supply voltage	V _{DD}			-0.3 to +7.0	V		
	V _{PP}			-0.3 to +13.5	V		
	AV _{DD}			-0.3 to V _{DD} +0.3	V		
	AV _{REF0}			-0.3 to V _{DD} +0.3	V		
	AV _{REF1}			-0.3 to V _{DD} +0.3	V		
	AV _{SS}			-0.3 to +0.3	V		
Input voltage	V _{I1}	P00 to P07, P10 to P17, P20 to P27, P30 to P37, P40 to 47, P50 to P57, P64 to P67, P70 to P72, P120 to P127, P130, P131, X1, X2, XT2, RESET		-0.3 to V _{DD} +0.3	V		
	V _{I2}	P60 to P63	N-ch open drain	-0.3 to +16	V		
	V _{I3}	A9	PROM programming mode	-0.3 to +13.5	V		
Output voltage	V _O			-0.3 to V _{DD} +0.3	V		
Analog input voltage	V _{AN}	P10 to P17	Analog input pins	AV _{SS} -0.3 to AV _{REF0} +0.3	V		
Output current high	I _{OH}	1 pin		-10	mA		
		Total for P01 to P06, P30 to P37, P56, P57, P60 to P67, P120 to P127		-15	mA		
		Total for P10 to P17, P20 to P27, P40 to P47, P50 to P55, P70 to P72, P130, P131		-15	mA		
Output current low	I _{OL} ^{Note}	1 pin	Peak value	30	mA		
			R.m.s. value	15	mA		
		Total for P50 to P55	Peak value	100	mA		
			R.m.s. value	70	mA		
		Total for P56, P57, P60 to P63	Peak value	100	mA		
			R.m.s. value	70	mA		
		Total for P10 to P17, P20 to P27, P40 to P47, P70 to P72, P130, P131	Peak value	50	mA		
			R.m.s. value	20	mA		
		Total for P01 to P06, P30 to P37, P64 to P67, P120 to P127	Peak value	50	mA		
			R.m.s.	20	mA		
		Operating ambient temperature	T _A			-40 to +85	°C
		Storage temperature	T _{stg}			-65 to +150	°C
Total power dissipation	P _d			650	mW		

Note The r.m.s. value should be calculated as follows: [R.m.s. value] = [Peak value] x √Duty

Caution Product quality may suffer if the absolute maximum rating is exceeded for even a single parameter, or even momentarily. In other words, the absolute maximum ratings are rated values at which the product is on the verge of suffering physical damage, and therefore the product must be used under conditions which ensure that the absolute maximum ratings are not exceeded.

Remark Unless specified otherwise, dual-function pin characteristics are the same as port pin characteristics.

MAIN SYSTEM CLOCK OSCILLATOR CHARACTERISTICS (T_A = -40 to +85°C, V_{DD} = 2.7 to 5.5 V)

Resonator	Recommended Circuit	Parameter	Test Conditions	MIN.	TYP.	MAX.	Unit
Ceramic resonator		Oscillator frequency (f _x) ^{Note1}	V _{DD} = Oscillation voltage range	1.0	6.0	6.29	MHz
		Oscillator stabilization time ^{Note2}	After V _{DD} has reached MIN. of oscillation voltage range			4	ms
Crystal resonator		Oscillator frequency (f _x) ^{Note1}		1.0	6.0	6.29	MHz
		Oscillator stabilization time ^{Note2}	V _{DD} = 4.5 to 5.5 V			10 30	ms
External clock		X1 input frequency (f _x) ^{Note1}		1.0	6.0	6.29	MHz
		X1 input high-/low-level width (t _{xH} /t _{xL})	When f _{xx} = f _x	85		500	ns
			Other than above	72		500	ns

- Notes**
1. Only the oscillator characteristics are shown. See the AC characteristics for instruction execution times.
 2. This is the time required for oscillation to stabilize after a reset or STOP mode release.

Cautions 1. When the main system clock oscillator is used, the following should be noted concerning wiring in the area in the figure enclosed by a broken line to prevent the influence of wiring capacitance, etc.

- The wiring should be kept as short as possible.
- No other signal lines should be crossed.
- Keep away from lines carrying a high fluctuating current.
- The oscillator capacitor grounding point should always be at the same potential as V_{SS}.
- Do not connect to a ground pattern carrying a high current.
- A signal should not be taken from the oscillator.

2. When the main system clock is stopped and the device is operating on the subsystem clock, wait until the oscillation stabilization time has been secured by the program before switching back to the main system clock.

★ **Remark** For the resonator selection and oscillator constant, customers are requested to either evaluate the oscillation themselves or apply to the resonator manufacturer for evaluation.

SUBSYSTEM CLOCK OSILLATOR CHARACTERISTICS (T_A = -40 to +85°C, V_{DD} = 2.7 to 5.5 V)

Resonator	Recommended Circuit	Parameter	Test Conditions	MIN.	TYP.	MAX.	Unit
Crystal resonator		Oscillation frequency (f _{XT}) ^{Note1}		32	32.768	35	MHz
		Oscillation stabilization time ^{Note2}	V _{DD} = 4.5 to 5.5 V		1.2	2	s
External clock		X1 input frequency (f _{XT}) ^{Note1}		32		100	kHz
		X1 input high-/low-level width (t _{XTH} /t _{XTL})		5		15	μs

Notes 1. Only the oscillator characteristics are shown. See the AC characteristics for instruction execution times.

2. This is the time required for oscillation to stabilize after power (V_{DD}) is turned on.

Cautions 1. When the subsystem clock oscillator is used, the following should be noted concerning wiring in the area in the figure enclosed by a broken line to prevent the influence of wiring capacitance, etc.

- The wiring should be kept as short as possible.
- No other signal lines should be crossed.
- Keep away from lines carrying a high fluctuating current.
- The oscillator capacitor grounding point should always be at the same potential as V_{SS}.
- Do not connect to a ground pattern carrying a high current.
- A signal should not be taken from the oscillator.

2. The subsystem clock oscillator is a low-amplitude circuit in order to achieve a low consumption current, and is more prone to misoperation due to noise than the main system clock oscillator. Particular care is therefore required with the wiring method when the subsystem clock is used.

★ **Remark** For the resonator selection and oscillator constant, customers are requested to either evaluate the oscillation themselves or apply to the resonator manufacturer for evaluation.

CAPACITANCE (T_A = 25°C, V_{DD} = V_{SS} = 0 V)

Parameter	Symbol	Test Conditions		MIN.	TYP.	MAX.	Unit
Input capacitance	C _{IN}	f = 1 MHz Unmeasured pins returned to 0 V.				15	pF
Input/output capacitance	C _{IO}	f = 1 MHz Unmeasured pins returned to 0	P01 to P06, P10 to P17, P20 to P27, P30 to P37, P40 to P47, P50 to P57, P64 to P67, P70 to P72, P120 to P127, P130, P131			15	pF
			P60 to P63			20	pF

Remark Unless specified otherwise, dual-function pin characteristics are the same as port pin characteristics.

DC CHARACTERISTICS (T_A = -40 to +85°C, V_{DD} = 2.7 to 5.5 V)

Parameter	Symbol	Conditions	MIN.	TYP.	MAX.	Unit	
Input voltage high	V _{IH1}	P10 to P17, P21, P23, P30 to P32, P35 to P37, P40 to P47, P50 to P57, P64 to P67, P71, P120 to P127, P130, P131	0.7 V _{DD}		V _{DD}	V	
	V _{IH2}	P00 to P06, P20, P22, P24 to P27, P33, P34, P70, P72, RESET	0.8 V _{DD}		V _{DD}	V	
	V _{IH3}	P60 to P63, N-ch open drain	0.7 V _{DD}		15	V	
	V _{IH4}	X1, X2	V _{DD} -0.5		V _{DD}	V	
	V _{IH5}	XT1/P07, XT2	4.5 V ≤ V _{DD} ≤ 5.5 V	0.8 V _{DD}		V _{DD}	V
2.7 V ≤ V _{DD} < 4.5 V			0.9 V _{DD}		V _{DD}	V	
Input voltage low	V _{IL1}	P10 to P17, P21, P23, P30 to P32, P35 to P37, P40 to P47, P50 to P57, P64 to P67, P71, P120 to P127, P130, P131	0		0.3 V _{DD}	V	
	V _{IL2}	P00 to P06, P20, P22, P24 to P27, P33, P34, P70, P72, RESET	0		0.2 V _{DD}	V	
	V _{IL3}	P60 to P63, N-ch open drain	4.5 V ≤ V _{DD} ≤ 5.5 V	0		0.3 V _{DD}	V
			2.7 V ≤ V _{DD} < 4.5 V	0		0.2 V _{DD}	V
	V _{IL4}	X1, X2	0		0.4	V	
V _{IL5}	XT1/P07, XT2	V _{DD} = 4.5 to 5.5 V	0		0.2 V _{DD}	V	
			0		0.1 V _{DD}	V	
Output voltage high	V _{OH1}	V _{DD} = 4.5 to 5.5 V, I _{OH} = -1 mA	V _{DD} -1.0			V	
		I _{OH} = -100 μA	V _{DD} -0.5			V	
Output voltage low	V _{OL1}	P50 to P57, P60 to P63	V _{DD} = 4.5 to 5.5 V, I _{OL} = 15 mA		0.4	2.0	V
		P01 to P06, P10 to P17, P20 to P27, P30 to P37, P40 to P47, P64 to P67, P70 to P72, P120 to P127, P130, P131	V _{DD} = 4.5 to 5.5 V, I _{OL} = 1.6 mA			0.4	V
	V _{OL2}	SB0, SB1, SCK0	V _{DD} = 4.5 to 5.5 V, Open drain, at pulled up (R = 1 kΩ)			0.2 V _{DD}	V
	V _{OL3}	I _{OL} = 400 μA				0.5	V

Remark Unless specified otherwise, dual-function pin characteristics are the same as port pin characteristics.

DC CHARACTERISTICS (T_A = -40 to +85°C, V_{DD} = 2.7 to 5.5 V)

Parameter	Symbol	Test Conditions		MIN.	TYP.	MAX.	Unit
Input leakage current high	I _{LIH1}	V _{IN} = V _{DD}	P00 to P06, P10 to P17, P20 to P27, P30 to P37, P40 to P47, P50 to P57, P60 to P67, P70 to P72, $\overline{\text{RESET}}$ P120 to P127, P130, P131, $\overline{\text{RESET}}$			3	μA
	I _{LIH2}		X1, X2, XT1/P07, XT2			20	μA
	I _{LIH3}	V _{IN} = 15V	P60 to P63			80	μA
Input leakage current low	I _{LIL1}	V _{IN} = 0 V	P00 to P06, P10 to P17, P20 to P27, P30 to P37, P40 to P47, P50 to P57, P60 to P67, P70 to P72, $\overline{\text{RESET}}$ P120 to P127, P130, P131, $\overline{\text{RESET}}$			-3	μA
	I _{LIL2}		X1, X2, XT1/P07, XT2			-20	μA
	I _{LIL3}		P60 to P63			-3 ^{Note}	μA
Output leakage current high	I _{LOH}	V _{OUT} = V _{DD}				3	μA
Output leakage current low	I _{LOL}	V _{OUT} = 0 V				-3	μA
Software pull-up resistor	R	V _{IN} = 0 V, P01 to P06, P10 to P17, P20 to P27, P30 to P37, P40 to P47, P50 to P57, P64 to P67, P70 to P72, P120 to P127, P130, P131	4.5 ≤ V _{DD} ≤ 5.5 V	15	40	90	kΩ
			2.7 ≤ V _{DD} < 4.5 V	20		500	kΩ

Note For P60-P63, a low-level input leak current of -200 μA (MAX.) flows only during the 1.5 clocks (no-wait time) after an instruction has been executed to read out port 6 (P6) or port mode register 6 (PM6). Outside the period of 1.5 clocks following execution a read-out instruction, the current is -3 μA (MAX.).

Remark Unless specified otherwise, dual-function pin characteristics are the same as port pin characteristics.

DC CHARACTERISTICS (T_A = -40 to +85°C, V_{DD} = 2.7 to 5.5 V)

Parameter	Symbol	Test Conditions	MIN.	TYP.	MAX.	Unit
Supply current ^{Note 1}	I _{DD1}	5.0 MHz crystal oscillation operating mode (f _{XX} = 2.5 MHz) ^{Note2}	V _{DD} = 5.0V±10% ^{Note6}	5	15	mA
			V _{DD} = 3.0V±10% ^{Note7}	0.7	2.7	mA
		5.0 MHz crystal oscillation operating mode (f _{XX} = 5.0 MHz) ^{Note3}	V _{DD} = 5.0V±10% ^{Note6}	9	30	mA
			V _{DD} = 3.0V±10% ^{Note7}	1	3.7	mA
		6.29 MHz crystal oscillation operating mode (f _{XX} = 2.1 MHz) ^{Note4}	V _{DD} = 5.0V±10% ^{Note6}	4.8	17.4	mA
6.29 MHz crystal oscillation operating mode (f _{XX} = 4.19 MHz) ^{Note5}	V _{DD} = 5.0V±10% ^{Note6}	8.5	28.5	mA		

- Notes**
1. Currents AV_{REF0}, AV_{REF1}, AV_{DD}, and the port current (including the current flowing in the internal pull-up resistor) are not included.
 2. When bit 0 of clock switchover selection register 1 has been set to 0, bit 0 of clock switchover selection register 2 has been set to 0, and the oscillator mode selection register has been set to 00H.
 3. When bit 0 of clock switchover selection register 1 has been set to 0, bit 0 of clock switchover selection register 2 has been set to 0, and the oscillator mode selection register has been set to 01H.
 4. When bit 0 of clock switchover selection register 1 has been set to 1, bit 0 of clock switchover selection register 2 has been set to 0, and the oscillator mode selection register has been set to 00H.
Indicates only the power supply current characteristic. For IEBus ratings, refer to the IEBus controller characteristics.
 5. When bit 0 of clock switchover selection register 1 has been set to 1, bit 0 of clock switchover selection register 2 has been set to 0, and the oscillator mode selection register has been set to 01H.
Indicates only the power supply current characteristic. For IEBus ratings, refer to the IEBus controller characteristics.
 6. When in high-speed mode (when the processor clock control register has been set to 00H).
 7. When in low-speed mode (when the processor clock control register has been set to 04H).

Remark f_{XX}: Main system clock frequency

DC CHARACTERISTICS (T_A = -40 to +85°C, V_{DD} = 2.7 to 5.5 V)

Parameter	Symbol	Test Conditions	MIN.	TYP.	MAX.	Unit	
Supply current ^{Note 1}	I _{DD2}	5.0 MHz crystal oscillation HALT mode (f _{xx} = 2.5 MHz) ^{Note 2}	V _{DD} = 5.0V±10% ^{Note 7}		1.5	4.5	mA
			V _{DD} = 3.0V±10% ^{Note 8}		0.5	1.5	mA
		5.0 MHz crystal oscillation HALT mode (f _{xx} = 5.0 MHz) ^{Note 3}	V _{DD} = 5.0V±10% ^{Note 7}		1.8	5.4	mA
			V _{DD} = 3.0V±10% ^{Note 8}		0.7	2.1	mA
	6.29 MHz crystal oscillation HALT mode (f _{xx} = 2.1 MHz) ^{Note 4}	V _{DD} = 5.0V±10% ^{Note 7}		1.5	4.5	mA	
		V _{DD} = 5.0V±10% ^{Note 7}		1.8	5.4	mA	
	I _{DD3}	32.768 kHz crystal oscillation operating mode ^{Note 6}	V _{DD} = 5.0V±10%		135	270	μA
			V _{DD} = 3.0V±10%		95	190	μA
	I _{DD4}	32.768 kHz crystal oscillation HALT mode ^{Note 6}	V _{DD} = 5.0V±10%		25	55	μA
			V _{DD} = 3.0V±10%		5	15	μA
	I _{DD5}	XT1 = 0 V STOP mode Feedback resistor used	V _{DD} = 5.0V±10%		1	30	μA
			V _{DD} = 3.0V±10%		0.5	10	μA
I _{DD6}	XT1 = 0 V STOP mode Feedback resistor not used	V _{DD} = 5.0V±10%		0.1	30	μA	
		V _{DD} = 3.0V±10%		0.05	10	μA	

- Notes**
1. Currents AV_{REF0}, AV_{REF1}, AV_{DD}, and the port current (including the current flowing in the internal pull-up resistor) are not included.
 2. When bit 0 of clock switchover selection register 1 has been set to 0, bit 0 of clock switchover selection register 2 has been set to 0, and the oscillator mode selection register has been set to 00H.
 3. When bit 0 of clock switchover selection register 1 has been set to 0, bit 0 of clock switchover selection register 2 has been set to 0, and the oscillator mode selection register has been set to 01H.
 4. When bit 0 of clock switchover selection register 1 has been set to 1, bit 0 of clock switchover selection register 2 has been set to 0, and the oscillator mode selection register has been set to 00H.
Indicates only the power supply current characteristic. For IEBus ratings, refer to the IEBus controller characteristics.
 5. When bit 0 of clock switchover selection register 1 has been set to 1, bit 0 of clock switchover selection register 2 has been set to 0, and the oscillator mode selection register has been set to 01H.
Indicates only the power supply current characteristic. For IEBus ratings, refer to the IEBus controller characteristics.
 6. When the main system clock is stopped.
 7. When in high-speed mode (when the processor clock control register has been set to 00H).
 8. When in low-speed mode (when the processor clock control register has been set to 04H).

Remark f_{xx} : Main system clock frequency

AC CHARACTERISTICS

(1) Basic Operation (T_A = -40 to +85°C, V_{DD} = 2.7 to 5.5 V)

Parameter	Symbol	Test Conditions		MIN.	TYP.	MAX.	Unit	
Cycle time (minimum instruction execution timke)	T _{CY}	Operating on main system clock (MCS = 0 ^{Note 1})	f _{XX} = f _X /3	4.0 V ≤ V _{DD} ≤ 5.5 V	0.95		64	μs
			f _{XX} = f _X /6	2.7 V ≤ V _{DD} ≤ 5.5 V	1.91		64	μs
			f _{XX} = f _X /9	4.0 V ≤ V _{DD} ≤ 5.5 V	2.86		64	μs
			f _{XX} = f _X /2	2.7 V ≤ V _{DD} ≤ 5.5 V	0.8		64	μs
		Operating on main system clock (MCS = 1 ^{Note 2})	f _{XX} = 2f _X /3	4.5 V ≤ V _{DD} ≤ 5.5 V	0.48		32	μs
				4.0 V ≤ V _{DD} < 4.5 V	0.95		32	μs
			f _{XX} = f _X /3	2.7 V ≤ V _{DD} ≤ 5.5 V	0.95		32	μs
				4.0 V ≤ V _{DD} ≤ 5.5 V	1.43		32	μs
			f _{XX} = 2f _X /9	4.0 V ≤ V _{DD} ≤ 5.5 V	1.43		32	μs
				4.5 V ≤ V _{DD} ≤ 5.5 V	0.4		32	μs
		2.7 V ≤ V _{DD} < 4.5 V	0.8		32	μs		
		Operating on subsystem clock		114	122	125	μs	
TI00 input high-/low-level width	t _{TIH00} ,	3.5 V ≤ V _{DD} ≤ 5.5 V		2/f _{sam} +0.1 ^{Note3}			μs	
	t _{TIL00}	2.7 V ≤ V _{DD} < 3.5 V		2/f _{sam} +0.2 ^{Note3}			μs	
TI01 input high-/low-level width	t _{TIH01} ,			10			μs	
	t _{TIL01}						μs	
TI1, TI2 input frequency	f _{TI1}	4.5 V ≤ V _{DD} ≤ 5.5 V		0		4	MHz	
				0		275	kHz	
TI1, TI2 input high-/low-level width	t _{TIH1} ,	4.5 V ≤ V _{DD} ≤ 5.5 V		100			ns	
	t _{TIL1}			1.8			μs	
Interrupt input high-/low-level width	t _{INTH} ,	INTP0	3.5 V ≤ V _{DD} ≤ 5.5 V	2/f _{sam} +0.1 ^{Note3}			μs	
			2.7 V ≤ V _{DD} < 3.5 V	2/f _{sam} +0.2 ^{Note3}			μs	
	t _{INTL}	INTP1 to INTP6		10			μs	
		KR0 to KR7		10			μs	
RESET low-level width	t _{RST}			10			μs	

- Notes**
1. When oscillation mode selection register is set to 00H.
 2. When oscillation mode selection register is set to 01H.
 3. f_{sam} can be selected as f_{XX}/2^N, f_{XX}/32, f_{XX}/64, or f_{XX}/128 by bits 0 and 1 (SCS0 and SCS1) of the sampling clock selection register (N = 0 to 4).

- Remarks**
1. f_{XX} : Main system clock frequency (f_X or f_X/2)
 2. f_X : Main system clock oscillator frequency

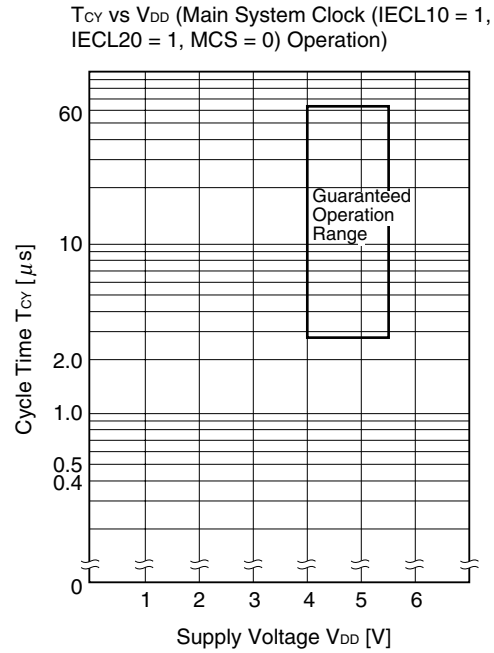
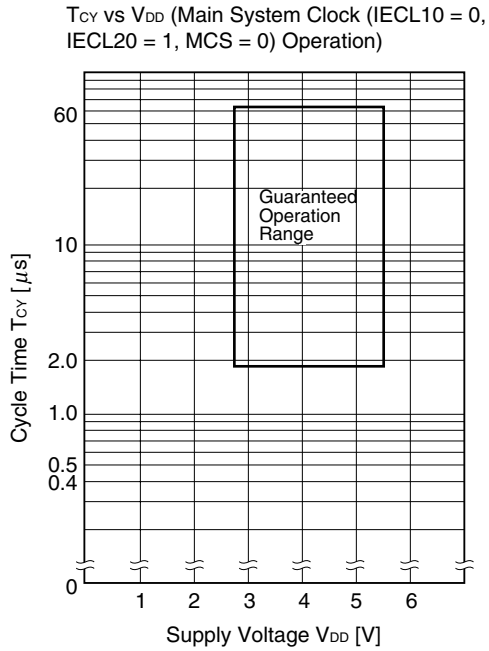
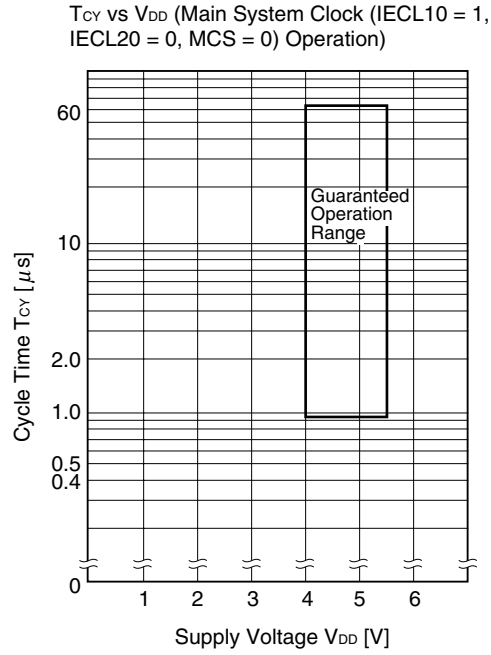
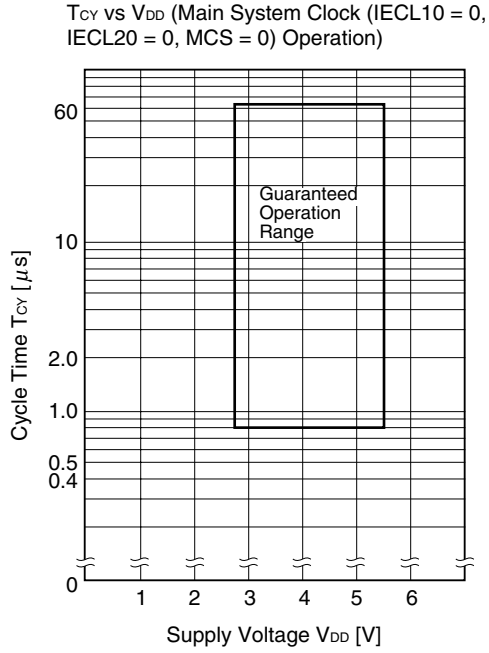

T_{CY} vs V_{DD} (Main System Clock (IECL10 = 0, IECL20 = 0, MCS = 1) Operation)

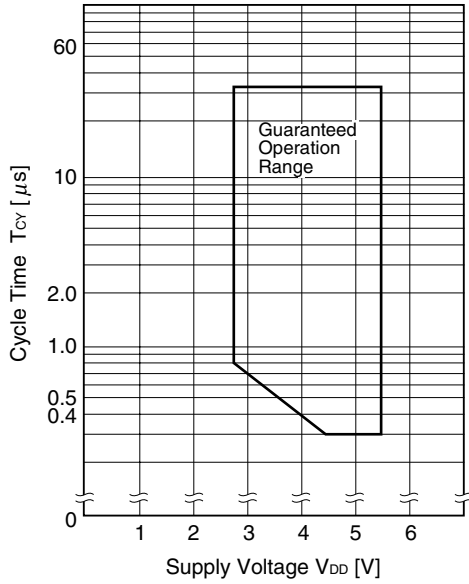

T_{CY} vs V_{DD} (Main System Clock (IECL10 = 1, IECL20 = 0, MCS = 1) Operation)

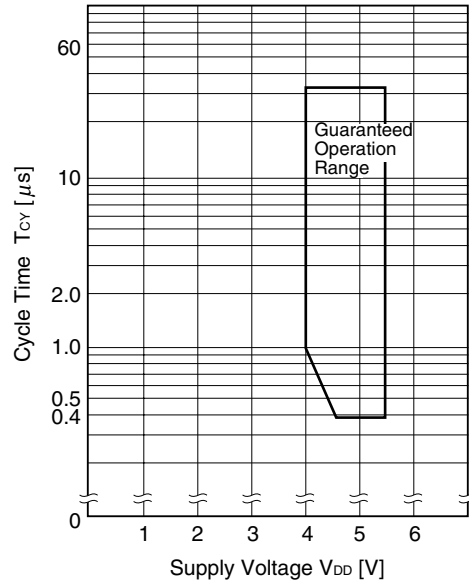

T_{CY} vs V_{DD} (Main System Clock (IECL10 = 0, IECL20 = 1, MCS = 1) Operation)

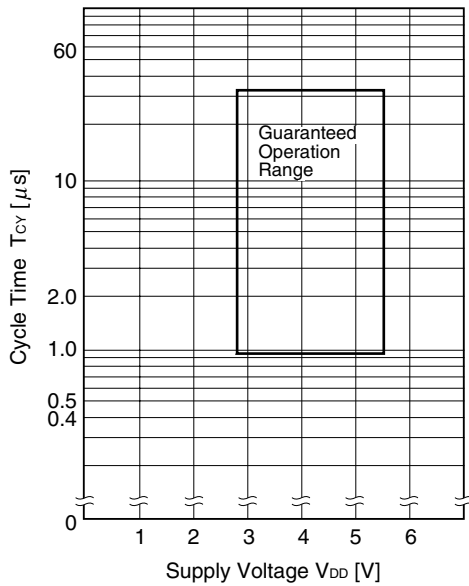

T_{CY} vs V_{DD} (Main System Clock (IECL10 = 1, IECL20 = 1, MCS = 1) Operation)

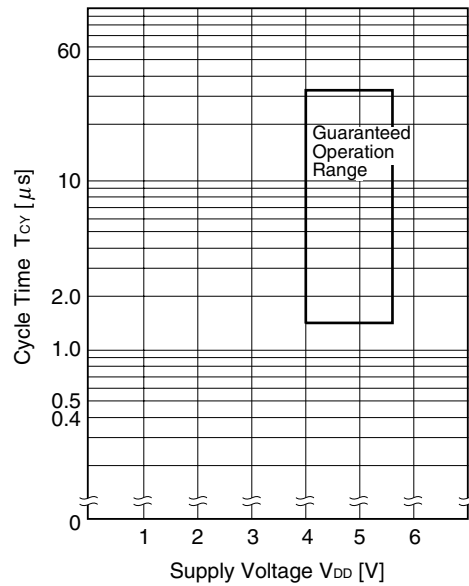

(2) Read/Write Operations

(a) When MCS = 1, PCC2 to PCC0 = 000B (T_A = -40 to +85°C, V_{DD} = 4.5 to 5.5 V)

Parameter	Symbol	Test Conditions	MIN.	MAX.	Unit
ASTB high-level width	t _{ASTH}		0.85t _{cy} -50		ns
Address setup time	t _{ADS}		0.85t _{cy} -50		ns
Address hold time	t _{ADH}		50		ns
Data input time from address	t _{ADD1}			(2.85+2n)t _{cy} -80	ns
	t _{ADD2}			(4+2n)t _{cy} -100	ns
Data input time from $\overline{RD}\downarrow$	t _{RDD1}			(2+2n)t _{cy} -100	ns
	t _{RDD2}			(2.85+2n)t _{cy} -100	ns
Read data hold time	t _{RDH}		0		ns
\overline{RD} low-level width	t _{RDL1}		(2+2n)t _{cy} -60		ns
	t _{RDL2}		(2.85+2n)t _{cy} -60		ns
$\overline{WAIT}\downarrow$ input time from $\overline{RD}\downarrow$	t _{RDWT1}			0.85t _{cy} -50	ns
	t _{RDWT2}			2t _{cy} -60	ns
$\overline{WAIT}\downarrow$ input time from $\overline{WR}\downarrow$	t _{WRWT}			2t _{cy} -60	ns
\overline{WAIT} low-level width	t _{WTL}		(1.15+2n)t _{cy}	(2+2n)t _{cy}	ns
Write data setup time	t _{WDS}		(2.85+2n)t _{cy} -100		ns
Write data hold time	t _{WDH}		20		ns
\overline{WR} low-level width	t _{WRL1}		(2.85+2n)t _{cy} -60		ns
$\overline{RD}\downarrow$ delay time from ASTB \downarrow	t _{ASTRD}		25		ns
$\overline{WR}\downarrow$ delay time from ASTB \downarrow	t _{ASTWR}		0.85t _{cy} +20		ns
ASTB \uparrow delay time from $\overline{RD}\uparrow$ in external fetch	t _{RDAST}		0.85t _{cy} -10	1.15t _{cy} +20	ns
Address hold time from $\overline{RD}\uparrow$ in external fetch	t _{RDADH}		0.85t _{cy} -50	1.15t _{cy} +50	ns
Write data output time from $\overline{RD}\uparrow$	t _{RDWD}		40		ns
Write data output time from $\overline{WR}\downarrow$	t _{WRWD}		0	50	ns
Address hold time from $\overline{WR}\uparrow$	t _{WRADH}		0.85t _{cy}	1.15t _{cy} +40	ns
$\overline{RD}\uparrow$ delay time from $\overline{WAIT}\uparrow$	t _{WTRD}		1.15t _{cy} +40	3.15t _{cy} +40	ns
$\overline{WR}\uparrow$ delay time from $\overline{WAIT}\uparrow$	t _{WTWR}		1.15t _{cy} +30	3.15t _{cy} +30	ns

- Remarks**
1. MCS: Bit 0 of the oscillation mode selection register
 2. PCC2 to PCC0: Bit 2 to bit 0 of the processor clock control register
 3. t_{cy} = T_{cy}/4
 4. n indicates the number of waits.

(b) Except when MCS = 1, PCC2 to PCC0 = 000B ($T_A = -40$ to $+85^\circ\text{C}$, $V_{DD} = 2.7$ to 5.5 V)

Parameter	Symbol	Test Conditions	MIN.	MAX.	Unit
ASTB high-level width	t_{ASTH}		$t_{CY} - 80$		ns
Address setup time	t_{ADS}		$t_{CY} - 80$		ns
Address hold time	t_{ADH}		$0.4t_{CY} - 10$		ns
Data input time from address	t_{ADD1}			$(3+2n)t_{CY} - 160$	ns
	t_{ADD2}			$(4+2n)t_{CY} - 200$	ns
Data input time from $\overline{RD}\downarrow$	t_{RDD1}			$(1.4+2n)t_{CY} - 70$	ns
	t_{RDD2}			$(2.4+2n)t_{CY} - 70$	ns
Read data hold time	t_{RDH}		0		ns
\overline{RD} low-level width	t_{RDL1}		$(1.4+2n)t_{CY} - 20$		ns
	t_{RDL2}		$(2.4+2n)t_{CY} - 20$		ns
$\overline{WAIT}\downarrow$ input time from $\overline{RD}\downarrow$	t_{RDWT1}			$t_{CY} - 100$	ns
	t_{RDWT2}			$2t_{CY} - 100$	ns
$\overline{WAIT}\downarrow$ input time from $\overline{WR}\downarrow$	t_{WRWT}			$2t_{CY} - 100$	ns
\overline{WAIT} low-level width	t_{WTL}		$(1+2n)t_{CY}$	$(2+2n)t_{CY}$	ns
Write data setup time	t_{WDS}		$(2.4+2n)t_{CY} - 60$		ns
Write data hold time	t_{WDH}		20		ns
\overline{WR} low-level width	t_{WRL1}		$(2.4+2n)t_{CY} - 20$		ns
$\overline{RD}\downarrow$ delay time from $\overline{ASTB}\downarrow$	t_{ASTRD}		$0.4t_{CY} - 30$		ns
$\overline{WR}\downarrow$ delay time from $\overline{ASTB}\downarrow$	t_{ASTWR}		$1.4t_{CY} - 30$		ns
ASTB \uparrow delay time from $\overline{RD}\uparrow$ in external fetch	t_{RDAST}		$t_{CY} - 10$	$t_{CY} + 20$	ns
Address hold time from $\overline{RD}\uparrow$ in external fetch	t_{RDADH}		$t_{CY} - 50$	$t_{CY} + 50$	ns
Write data output time from $\overline{RD}\uparrow$	t_{RDWD}		$0.4t_{CY} - 20$		ns
Write data output time from $\overline{WR}\downarrow$	t_{WRWD}		0	60	ns
Address hold time from $\overline{WR}\uparrow$	t_{WRADH}		t_{CY}	$t_{CY} + 60$	ns
$\overline{RD}\uparrow$ delay time from $\overline{WAIT}\uparrow$	t_{WTRD}		$0.6t_{CY} + 180$	$2.6t_{CY} + 180$	ns
$\overline{WR}\uparrow$ delay time from $\overline{WAIT}\uparrow$	t_{WTWR}		$0.6t_{CY} + 120$	$2.6t_{CY} + 120$	ns

- Remarks**
1. MCS: Bit 0 of the oscillation mode selection register
 2. PCC2 to PCC0: Bit 2 to bit 0 of the processor clock control register
 3. $t_{CY} = T_{CY}/4$
 4. n indicates the number of waits.

(3) Serial Interface (T_A = -40 to +85°C, V_{DD} = 2.7 to 5.5 V)

(a) Serial interface channel 0

(i) 3-wire serial I/O mode ($\overline{\text{SCK0}}$... internal clock output)

Parameter	Symbol	Test Conditions	MIN.	TYP.	MAX.	Unit
$\overline{\text{SCK0}}$ cycle time	t _{KCY1}	V _{DD} = 4.5 to 5.5 V	800			ns
			1600			ns
$\overline{\text{SCK0}}$ high-/low-level width	t _{KH1} ,	V _{DD} = 4.5 to 5.5 V	t _{KCY1} /2-50			ns
	t _{KL1}		t _{KCY1} /2-100			ns
SI0 setup time (vs. $\overline{\text{SCK0}}\uparrow$)	t _{SIK1}	V _{DD} = 4.5 to 5.5 V	100			ns
			150			ns
SI0 hold time (vs. $\overline{\text{SCK0}}\uparrow$)	t _{KS11}		400			ns
SO0 output delay time from $\overline{\text{SCK0}}\downarrow$	t _{KSO1}	C = 100pF ^{Note}			300	ns

Note C is the SO0 output line load capacitance.

(ii) 3-wire serial I/O mode ($\overline{\text{SCK0}}$... external clock input)

Parameter	Symbol	Test Conditions	MIN.	TYP.	MAX.	Unit
$\overline{\text{SCK0}}$ cycle time	t _{KCY2}	V _{DD} = 4.5 to 5.5 V	800			ns
			1600			ns
$\overline{\text{SCK0}}$ high-/low-level width	t _{KH2} ,	V _{DD} = 4.5 to 5.5 V	400			ns
	t _{KL2}		800			ns
SI0 setup time (vs. $\overline{\text{SCK0}}\uparrow$)	t _{SIK2}		100			ns
SI0 hold time (vs. $\overline{\text{SCK0}}\uparrow$)	t _{KS12}		400			ns
SO0 output delay time from $\overline{\text{SCK0}}\downarrow$	t _{KSO2}	C = 100pF ^{Note}			300	ns
$\overline{\text{SCK0}}$ rise, fall time	t _{R2} , t _{F2}	When using external device expansion function			160	ns
		When not using external device expansion function			1000	ns

Note C is the SO0 output line load capacitance.

(iii) SBI mode ($\overline{\text{SCK0}}$... internal clock output)

Parameter	Symbol	Test Conditions	MIN.	TYP.	MAX.	Unit
$\overline{\text{SCK0}}$ cycle time	t_{KCY3}	$V_{\text{DD}} = 4.5 \text{ to } 5.5 \text{ V}$	800			ns
			3200			ns
$\overline{\text{SCK0}}$ high-/low-level width	t_{KH3} ,	$V_{\text{DD}} = 4.5 \text{ to } 5.5 \text{ V}$	$t_{\text{KCY3}}/2-50$			ns
	t_{KL3}		$t_{\text{KCY3}}/2-100$			ns
SB0, SB1 setup time (vs. $\overline{\text{SCK0}}\uparrow$)	t_{SIK3}	$V_{\text{DD}} = 4.5 \text{ to } 5.5 \text{ V}$	100			ns
			300			ns
SB0, SB1 hold time (vs. $\overline{\text{SCK0}}\uparrow$)	t_{KSI3}		$t_{\text{KCY3}}/2$			ns
SB0, SB1 output delay time from $\overline{\text{SCK0}}\downarrow$	t_{KSO3}	R = 1kΩ, C = 100pF ^{Note}	$V_{\text{DD}} = 4.5 \text{ to } 5.5 \text{ V}$		250	ns
				0		1000
SB0, SB1 \downarrow from $\overline{\text{SCK0}}\uparrow$	t_{KSB}		t_{KCY3}			ns
$\overline{\text{SCK0}}\downarrow$ from SB0, SB1 \downarrow	t_{SBK}		t_{KCY3}			ns
SB0, SB1 high-level width	t_{SBH}		t_{KCY3}			ns
SB0, SB1 low-level width	t_{SBL}		t_{KCY3}			ns

Note R and C are the SB0 and SB1 output line load resistance and load capacitance.

(iv) SBI mode ($\overline{\text{SCK0}}$... external clock input)

Parameter	Symbol	Test Conditions	MIN.	TYP.	MAX.	Unit
$\overline{\text{SCK0}}$ cycle time	t_{KCY4}	$V_{\text{DD}} = 4.5 \text{ to } 5.5 \text{ V}$	800			ns
			3200			ns
$\overline{\text{SCK0}}$ high-/low-level width	t_{KH4} ,	$V_{\text{DD}} = 4.5 \text{ to } 5.5 \text{ V}$	400			ns
	t_{KL4}		1600			ns
SB0, SB1 setup time (vs. $\overline{\text{SCK0}}\uparrow$)	t_{SIK4}	$V_{\text{DD}} = 4.5 \text{ to } 5.5 \text{ V}$	100			ns
			300			ns
SB0, SB1 hold time (vs. $\overline{\text{SCK0}}\uparrow$)	t_{KSI4}		$t_{\text{KCY4}}/2$			ns
SB0, SB1 output delay time from $\overline{\text{SCK0}}\downarrow$	t_{KSO4}	R = 1kΩ, C = 100pF ^{Note}	$V_{\text{DD}} = 4.5 \text{ to } 5.5 \text{ V}$		300	ns
				0		1000
SB0, SB1 \downarrow from $\overline{\text{SCK0}}\uparrow$	t_{KSB}		t_{KCY4}			ns
$\overline{\text{SCK0}}\downarrow$ from SB0, SB1 \downarrow	t_{SBK}		t_{KCY4}			ns
SB0, SB1 high-level width	t_{SBH}		t_{KCY4}			ns
SB0, SB1 low-level width	t_{SBL}		t_{KCY4}			ns
$\overline{\text{SCK0}}$ rise, fall time	t_{R4} , t_{F4}	When using external device expansion function			160	ns
		When not using external device expansion function			1000	ns

Note R and C are the SB0 and SB1 output line load resistance and load capacitance.

(v) 2-wire serial I/O mode ($\overline{\text{SCK0}}$... internal clock output)

Parameter	Symbol	Test Conditions	MIN.	TYP.	MAX.	Unit	
$\overline{\text{SCK0}}$ cycle time	t_{KCY5}	R = 1kΩ, C = 100pF ^{Note}	V _{DD} = 4.5 to 5.5 V	1600			ns
				3200			ns
$\overline{\text{SCK0}}$ high-level width	t_{KH5}		$t_{\text{KCY5}}/2-160$			ns	
$\overline{\text{SCK0}}$ low-level width	t_{KL5}		$t_{\text{KCY5}}/2-50$			ns	
SB0, SB1 setup time (vs. $\overline{\text{SCK0}}\uparrow$)	t_{SIK5}	V _{DD} = 4.5 to 5.5 V	300			ns	
			350			ns	
SB0, SB1 hold time (vs. $\overline{\text{SCK0}}\uparrow$)	t_{SH5}		600			ns	
SB0, SB1 output delay time from $\overline{\text{SCK0}}\downarrow$	t_{KSO5}		0		300	ns	

Note R and C are the $\overline{\text{SCK0}}$, SB0 and SB1 output line load resistance and load capacitance.

(vi) 2-wire serial I/O mode ($\overline{\text{SCK0}}$... external clock input)

Parameter	Symbol	Test Conditions	MIN.	TYP.	MAX.	Unit
$\overline{\text{SCK0}}$ cycle time	t_{KCY6}	V _{DD} = 4.5 to 5.5 V	1600			ns
			3200			ns
$\overline{\text{SCK0}}$ high-level width	t_{KH6}		650			ns
$\overline{\text{SCK0}}$ low-level width	t_{KL6}		800			ns
SB0, SB1 setup time (vs. $\overline{\text{SCK0}}\uparrow$)	t_{SIK6}		100			ns
SB0, SB1 hold time (vs. $\overline{\text{SCK0}}\uparrow$)	t_{SH6}		$t_{\text{KCY6}}/2$			ns
SB0, SB1 output delay time from $\overline{\text{SCK0}}\downarrow$	t_{KSO6}	R = 1kΩ, C = 100pF ^{Note}	0		300	ns
$\overline{\text{SCK0}}$ rise, fall time	$t_{\text{R6}},$ t_{F6}	When using external device expansion function			160	ns
		When not using external device expansion function			1000	ns

Note R and C are the $\overline{\text{SCK0}}$, SB0 and SB1 output line load resistance and load capacitance.

(b) Serial interface channel 1**(i) 3-wire serial I/O mode ($\overline{\text{SCK1}}$... internal clock output)**

Parameter	Symbol	Test Conditions	MIN.	TYP.	MAX.	Unit
$\overline{\text{SCK1}}$ cycle time	t_{KCY7}	$V_{\text{DD}} = 4.5 \text{ to } 5.5 \text{ V}$	800			ns
			1600			ns
$\overline{\text{SCK1}}$ high-/low-level width	t_{KH7}	$V_{\text{DD}} = 4.5 \text{ to } 5.5 \text{ V}$	$t_{\text{KCY7}}/2-50$			ns
	t_{KL7}		$t_{\text{KCY7}}/2-100$			ns
SI1 setup time (vs. $\overline{\text{SCK1}}\uparrow$)	t_{SIK7}	$V_{\text{DD}} = 4.5 \text{ to } 5.5 \text{ V}$	100			ns
			150			ns
SI1 hold time (vs. $\overline{\text{SCK1}}\uparrow$)	t_{KSI7}		400			ns
SO1 output delay time from $\overline{\text{SCK1}}\downarrow$	t_{KSO7}	$C = 100\text{pF}$ ^{Note}			300	ns

Note C is the SO1 output line load capacitance.

(ii) 3-wire serial I/O mode ($\overline{\text{SCK1}}$... external clock input)

Parameter	Symbol	Test Conditions	MIN.	TYP.	MAX.	Unit
$\overline{\text{SCK1}}$ cycle time	t_{KCY8}	$V_{\text{DD}} = 4.5 \text{ to } 5.5 \text{ V}$	800			ns
			1600			ns
$\overline{\text{SCK1}}$ high-/low-level width	t_{KH8}	$V_{\text{DD}} = 4.5 \text{ to } 5.5 \text{ V}$	400			ns
	t_{KL8}		800			ns
SI1 setup time (vs. $\overline{\text{SCK1}}\uparrow$)	t_{SIK8}		100			ns
SI1 hold time (vs. $\overline{\text{SCK1}}\uparrow$)	t_{KSI8}		400			ns
SO1 output delay time from $\overline{\text{SCK1}}\downarrow$	t_{KSO8}	$C = 100\text{pF}$ ^{Note}			300	ns
$\overline{\text{SCK1}}$ rise, fall time	t_{r8} , t_{f8}	When using external device expansion function			160	ns
		When not using external device expansion function			1000	ns

Note C is the SO1 output line load capacitance.

(iii) Automatic transmission/reception function 3-wire serial I/O mode ($\overline{\text{SCK1}}$... internal clock output)

Parameter	Symbol	Test Conditions	MIN.	TYP.	MAX.	Unit
$\overline{\text{SCK1}}$ cycle time	t_{KCY9}	$V_{\text{DD}} = 4.5 \text{ to } 5.5 \text{ V}$	800			ns
			1600			ns
$\overline{\text{SCK1}}$ high-/low-level width	t_{KH9}	$V_{\text{DD}} = 4.5 \text{ to } 5.5 \text{ V}$	$t_{\text{KCY9}}/2-50$			ns
	t_{KL9}		$t_{\text{KCY9}}/2-100$			ns
SI1 setup time (vs. $\overline{\text{SCK1}}\uparrow$)	t_{SIK9}	$V_{\text{DD}} = 4.5 \text{ to } 5.5 \text{ V}$	100			ns
			150			ns
SI1 hold time (vs. $\overline{\text{SCK1}}\uparrow$)	t_{KSI9}		400			ns
SO1 output delay time from $\overline{\text{SCK1}}\downarrow$	t_{KSO9}	$C = 100 \text{ pF}^{\text{Note}}$ $V_{\text{DD}} = 4.5 \text{ to } 5.5 \text{ V}$			300	ns
STB \uparrow from $\overline{\text{SCK1}}\uparrow$	t_{SBD}		$t_{\text{KCY9}}/2-100$		$t_{\text{KCY9}}/2+100$	ns
Strobe signal high-level width	t_{SBW}		$t_{\text{KCY9}}-30$		$t_{\text{KCY9}}+30$	ns
Busy signal setup time (vs. busy signal detection timing)	t_{BYS}		100			ns
Busy signal hold time (vs. busy signal detection timing)	t_{BYH}	$V_{\text{DD}} = 4.5 \text{ to } 5.5 \text{ V}$	100			ns
			150			ns
$\overline{\text{SCK1}}\downarrow$ from busy inactivation	t_{SPS}				$2t_{\text{KCY9}}$	ns

Note C is the SO1 output line load capacitance.

(iv) Automatic transmission/reception function 3-wire serial I/O mode ($\overline{\text{SCK1}}$... external clock input)

Parameter	Symbol	Test Conditions	MIN.	TYP.	MAX.	Unit
$\overline{\text{SCK1}}$ cycle time	t_{KCY10}	$V_{\text{DD}} = 4.5 \text{ to } 5.5 \text{ V}$	800			ns
			1600			ns
$\overline{\text{SCK1}}$ high-/low-level width	t_{KH10}	$V_{\text{DD}} = 4.5 \text{ to } 5.5 \text{ V}$	400			ns
	t_{KL10}		800			ns
SI1 setup time (vs. $\overline{\text{SCK1}}\uparrow$)	t_{SIK10}		100			ns
SI1 hold time (vs. $\overline{\text{SCK1}}\uparrow$)	t_{KSI10}		400			ns
SO1 output delay time from $\overline{\text{SCK1}}\downarrow$	t_{KSO10}	$C = 100 \text{ pF}^{\text{Note}}$			300	ns
$\overline{\text{SCK1}}$ rise, fall time	t_{R10} t_{F10}	When using external device expansion function			160	ns
		When not using external device expansion function			1000	ns

Note C is the SO1 output line load capacitance.

(c) Serial interface channel 2

(i) 3-wire serial I/O mode ($\overline{\text{SCK2}}$... internal clock output)

Parameter	Symbol	Test Conditions	MIN.	TYP.	MAX.	Unit
$\overline{\text{SCK2}}$ cycle time	t_{KCY11}	$V_{\text{DD}} = 4.5 \text{ to } 5.5 \text{ V}$	800			ns
			1600			ns
$\overline{\text{SCK2}}$ high-/low-level width	t_{KH11} ,	$V_{\text{DD}} = 4.5 \text{ to } 5.5 \text{ V}$	$t_{\text{KCY11}}/2-50$			ns
	t_{KL11}		$t_{\text{KCY11}}/2-100$			ns
SI2 setup time (vs. $\overline{\text{SCK2}}\uparrow$)	t_{SIK11}	$V_{\text{DD}} = 4.5 \text{ to } 5.5 \text{ V}$	100			ns
			150			ns
SI2 hold time (vs. $\overline{\text{SCK2}}\uparrow$)	t_{KSH11}		400			ns
SO2 output delay time from $\overline{\text{SCK2}}\downarrow$	t_{KSO11}	$C = 100\text{pF}$ ^{Note}			300	ns

Note C is the SO2 output line load capacitance.

(ii) 3-wire serial I/O mode ($\overline{\text{SCK2}}$... external clock input)

Parameter	Symbol	Test Conditions	MIN.	TYP.	MAX.	Unit
$\overline{\text{SCK2}}$ cycle time	t_{KCY12}	$V_{\text{DD}} = 4.5 \text{ to } 5.5 \text{ V}$	800			ns
			1600			ns
$\overline{\text{SCK2}}$ high-/low-level width	t_{KH12} ,	$V_{\text{DD}} = 4.5 \text{ to } 5.5 \text{ V}$	400			ns
	t_{KL12}		800			ns
SI2 setup time (vs. $\overline{\text{SCK2}}\uparrow$)	t_{SIK12}		100			ns
SI2 hold time (vs. $\overline{\text{SCK2}}\uparrow$)	t_{KSH12}		400			ns
SO2 output delay time from $\overline{\text{SCK2}}\downarrow$	t_{KSO12}	$C = 100\text{pF}$ ^{Note}			300	ns
$\overline{\text{SCK2}}$ rise, fall time	t_{R12} , t_{F12}	When using external device expansion function			160	ns
		When not using external device expansion function			1000	ns

Note C is the SO2 output line load capacitance.

(iii) UART mode (Dedicated baud rate generator output)

Parameter	Symbol	Test Conditions	MIN.	TYP.	MAX.	Unit
Transfer rate		V _{DD} = 4.5 to 5.5 V			78125	bps
					39063	bps

(iv) UART mode (External clock input)

Parameter	Symbol	Test Conditions	MIN.	TYP.	MAX.	Unit
ASCK cycle time	t _{KCY13}	V _{DD} = 4.5 to 5.5 V	800			ns
			1600			ns
ASCK high-/low-level width	t _{KH13} , t _{KL13}	V _{DD} = 4.5 to 5.5 V	400			ns
			800			ns
Transfer rate		V _{DD} = 4.5 to 5.5 V			39063	bps
					19531	bps
SCK rise, fall time	t _{R13} , t _{F13}	When using external device expansion function			160	ns
		When not using external device expansion function			1000	ns

AC Timing Test Point (Excluding X1, XT1 Input)

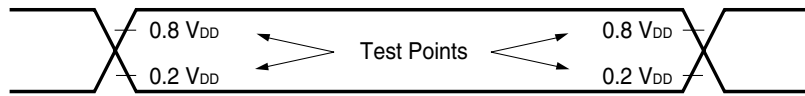

Clock Timing

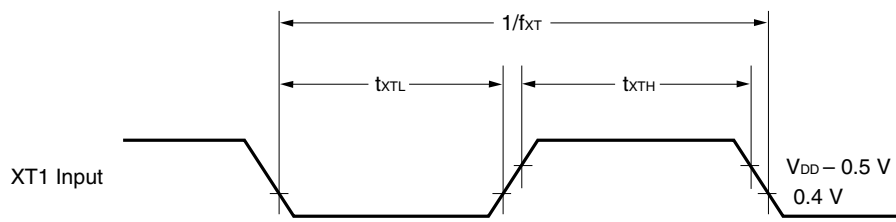
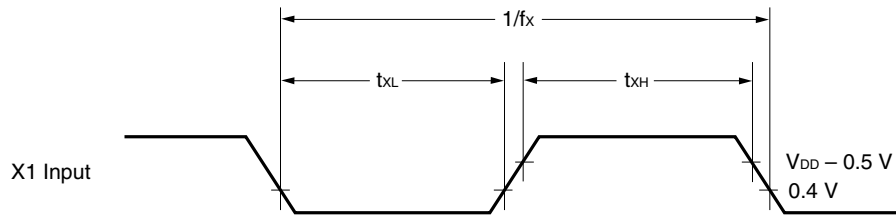

TI Timing

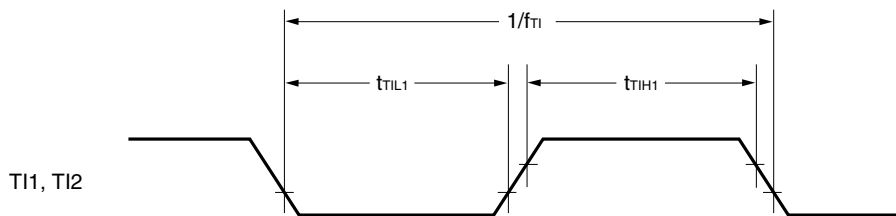
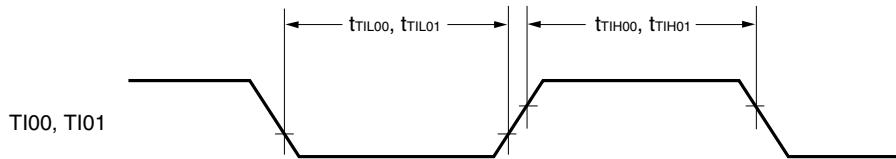

Read/Write Operations

External fetch (no wait):

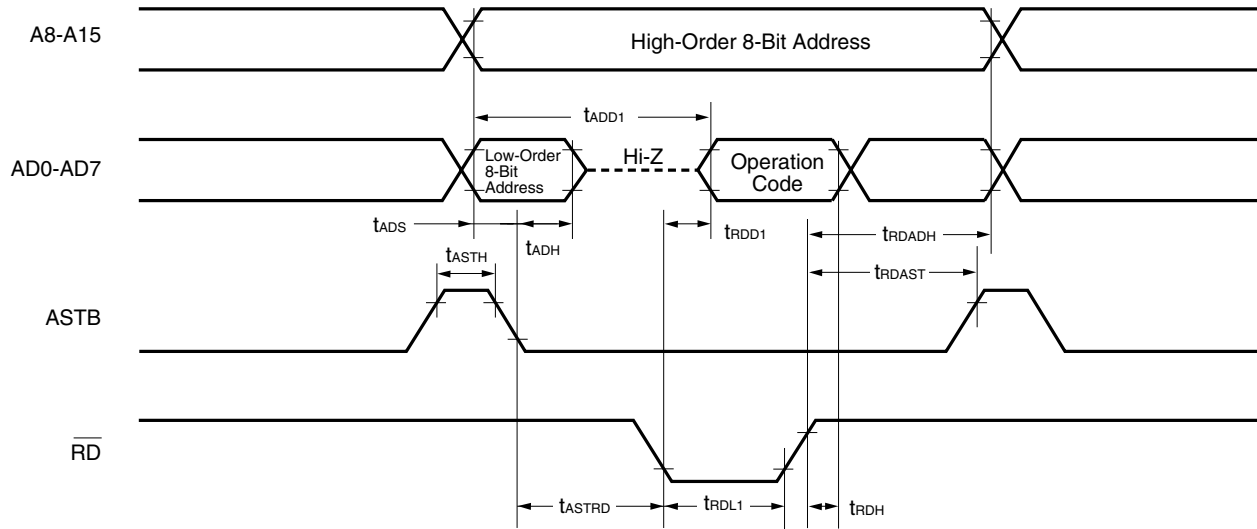

External fetch (wait insertion):

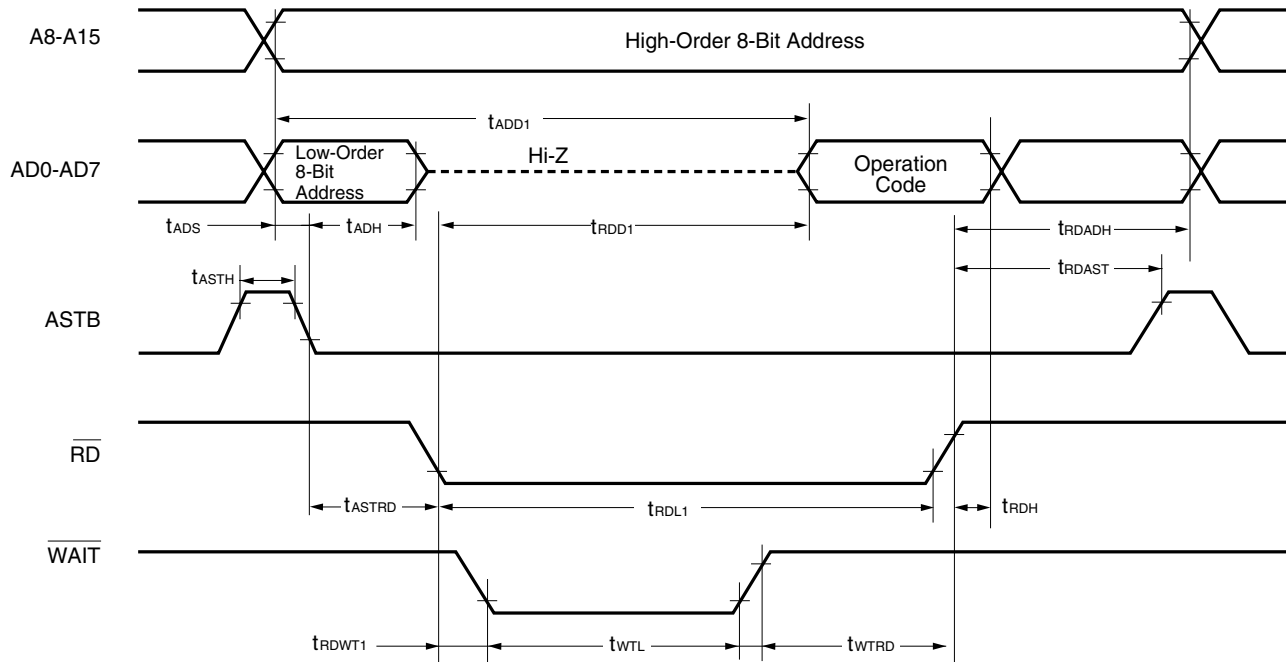

External data access (no wait):

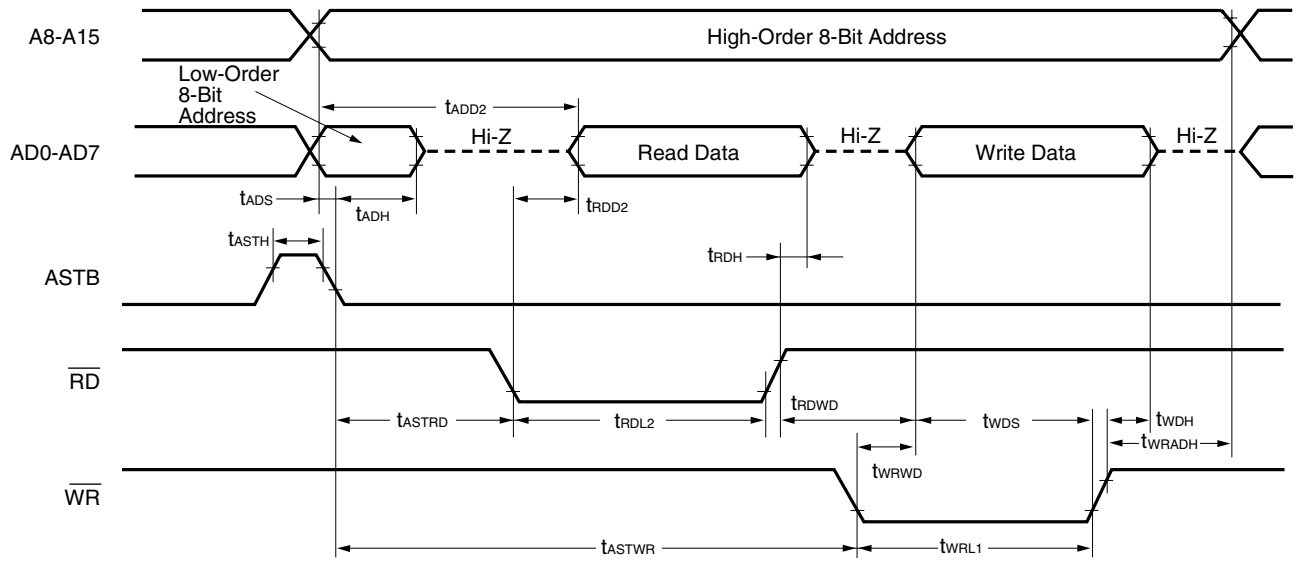

External data access (wait insertion):

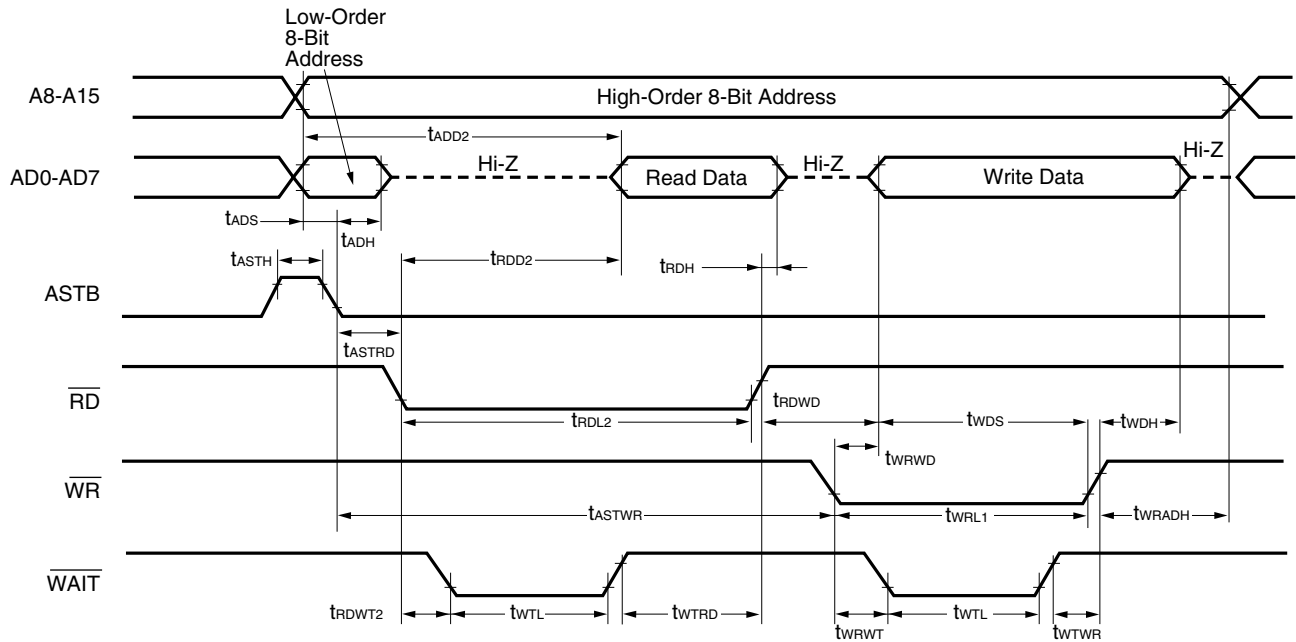

Serial Transfer Timing

3-wire serial I/O mode:

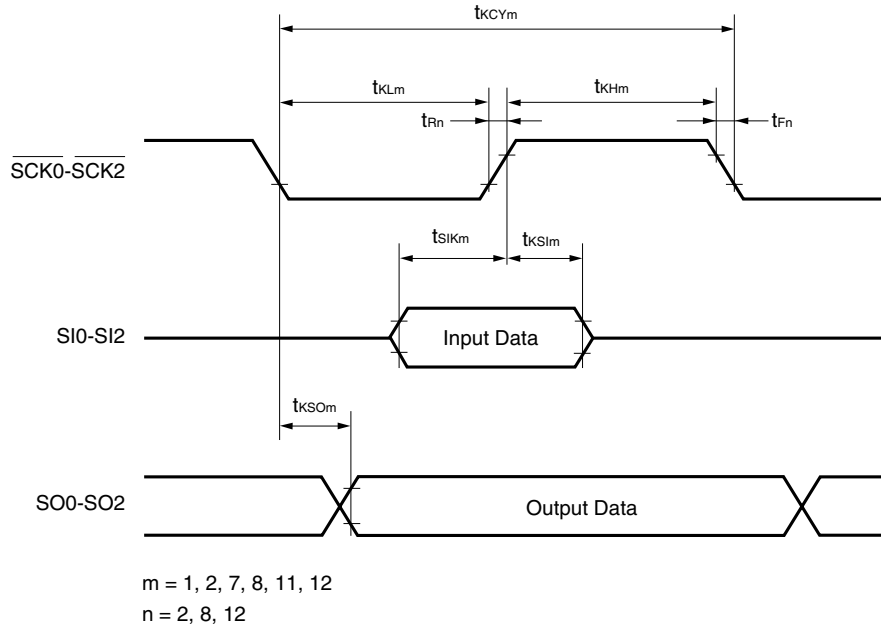

SBI mode (bus release signal transfer):

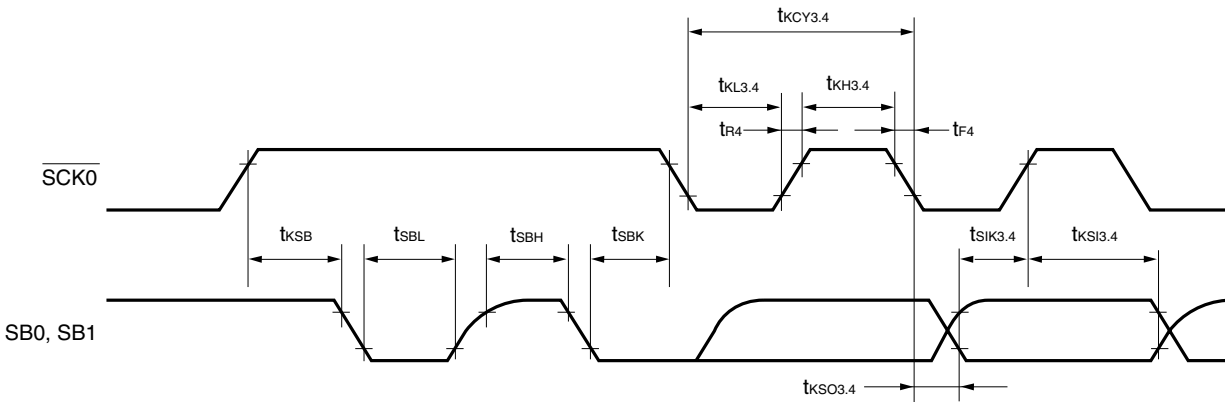

SBI mode (command signal transfer):

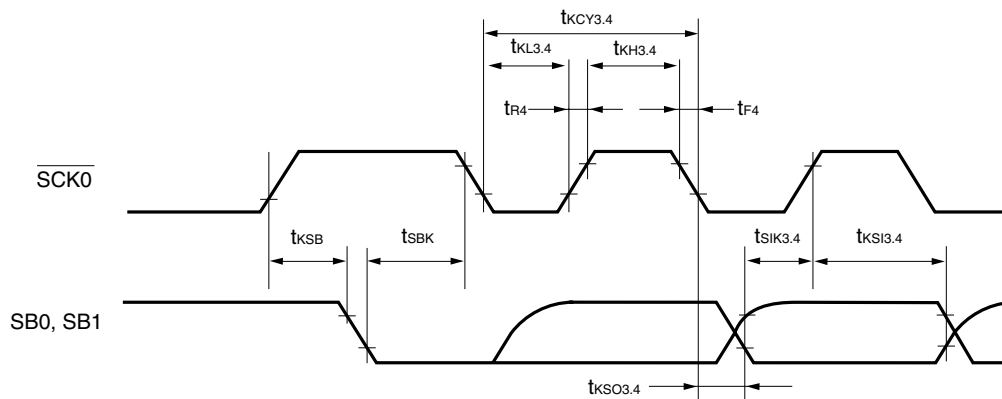

2-wire serial I/O mode:

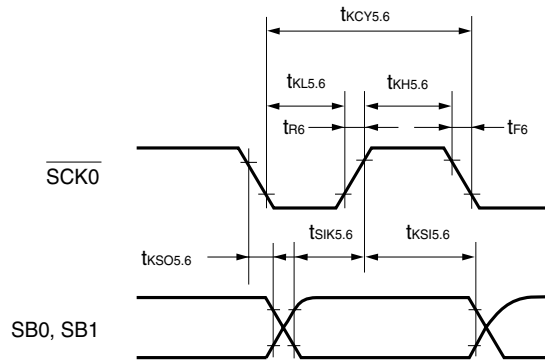

Automatic transmission/reception function 3-wire serial I/O mode:

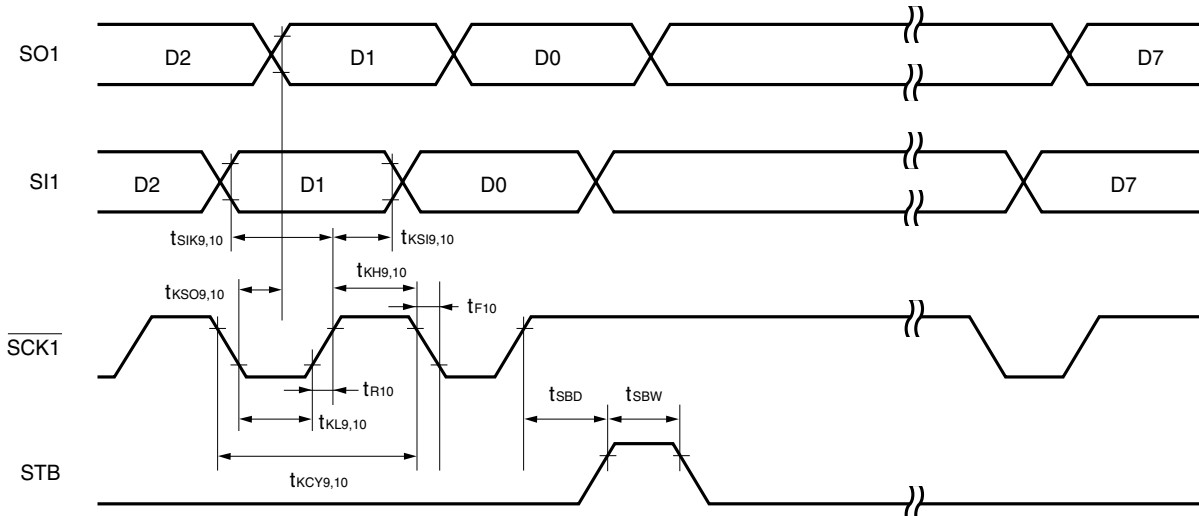

Automatic transmission/reception function 3-wire serial I/O mode (busy processing):

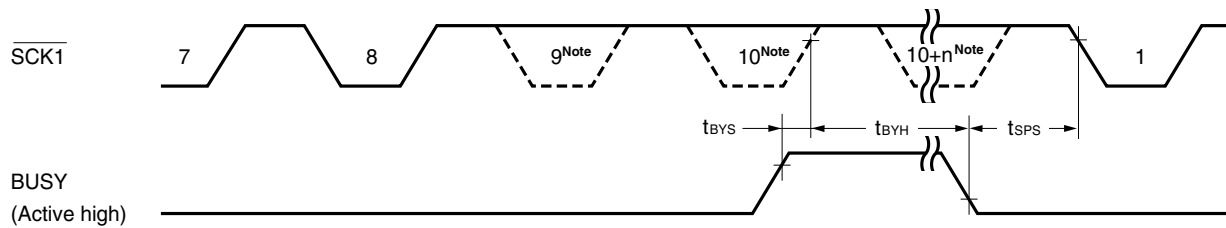

Note The signal is not actually low here, but is represented in this way to show the timing.

UART mode (external Clock Input):

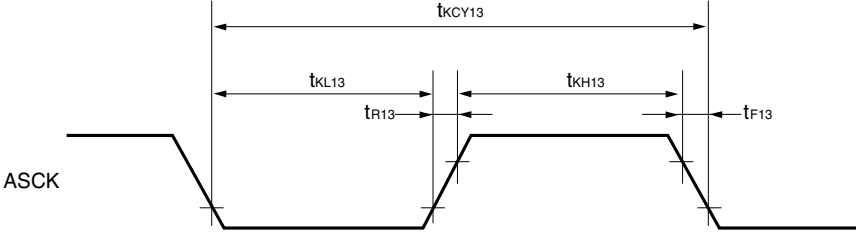

A/D Converter Characteristics (T_A = -40 to +85°C, AV_{DD} = V_{DD} = 2.7 to 5.5 V, AV_{SS} = V_{SS} = 0 V)

Parameter	Symbol	Test Conditions	MIN.	TYP.	MAX.	Unit	
Resolution			8	8	8	bit	
Total error ^{Note}		IEAD = 00H			±1.8	% FSR	
		IEAD = 01H	V _{DD} = 4.5 to 5.5 V		±2.2	±3.4	% FSR
					±2.6	±3.8	% FSR
Conversion time	t _{CONV}		19.1		200	μs	
Sampling time	t _{SAMP}		12/f _{xx}			μs	
Analog input voltage	V _{IAN}		AV _{SS}		AV _{REF0}	V	
Reference voltage	AV _{REF0}		2.7		AV _{DD}	V	
AV _{REF0} -AV _{SS} resistance	RA _{IREF0}		4	14		kΩ	

Note Excluding quantization error (±1/2 LSB). Shown as a percentage of the full scale value (% FSR).

- Remarks**
1. f_{xx} : Main system clock frequency (fx or fx/2)
 2. fx : Main system clock oscillator frequency

D/A Converter Characteristics (T_A = -40 to +85°C, V_{DD} = 2.7 to 5.5 V, AV_{SS} = V_{SS} = 0 V)

Parameter	Symbol	Test Conditions	MIN.	TYP.	MAX.	Unit
Resolution					8	bit
Total error		R = 2 MΩ ^{Note1}			1.2	%
		R = 4 MΩ ^{Note1}			0.8	%
		R = 10 MΩ ^{Note1}			0.6	%
Setting time		C = 30 pF ^{Note 1}	AV _{REF} = 4.5 to 5.5 V		10	μs
						15
Output resistor	R _{O0}	DACS0 = 55H		10		kΩ
	R _{O1}	DACS1 = 55H		10		kΩ
Analog reference voltage	AV _{REF1}		2.7		V _{DD}	V
AV _{REF1} current	AI _{REF1}	Note2			1.5	mA

- Notes**
1. R and C are the D/A converter output pin load resistance and load capacitance.
 2. Value for one D/A converter channel.

DATA MEMORY STOP MODE LOW SUPPLY VOLTAGE DATA RETENTION CHARACTERISTICS (T_A = -40 to +85°C)

Parameter	Symbol	Test Conditions	MIN.	TYP.	MAX.	Unit
Data retention supply voltage	V _{DDDR}		2.0		5.5	V
Data retention supply current	I _{DDDR}	V _{DDDR} = 2.0 V Subsystem clock stopped, feedback resistor disconnected		0.1	10	μA
Release signal setup time	t _{SREL}		0			μs
Oscillation stabilization wait time	t _{WAIT}	Release by $\overline{\text{RESET}}$		2 ¹⁷ /f _x		ms
		Release by interrupt		Note		ms

Note 2¹²/f_{xx}, or 2¹⁴/f_{xx} through 2¹⁷f_{xx} can be selected by bits 0 to 2 (OSTS0 to OSTS2) of the oscillation stabilization time selection register.

Remark f_{xx} : Main system clock frequency
f_x : Main system clock oscillator frequency

Data Retention Timing (STOP mode release by $\overline{\text{RESET}}$)

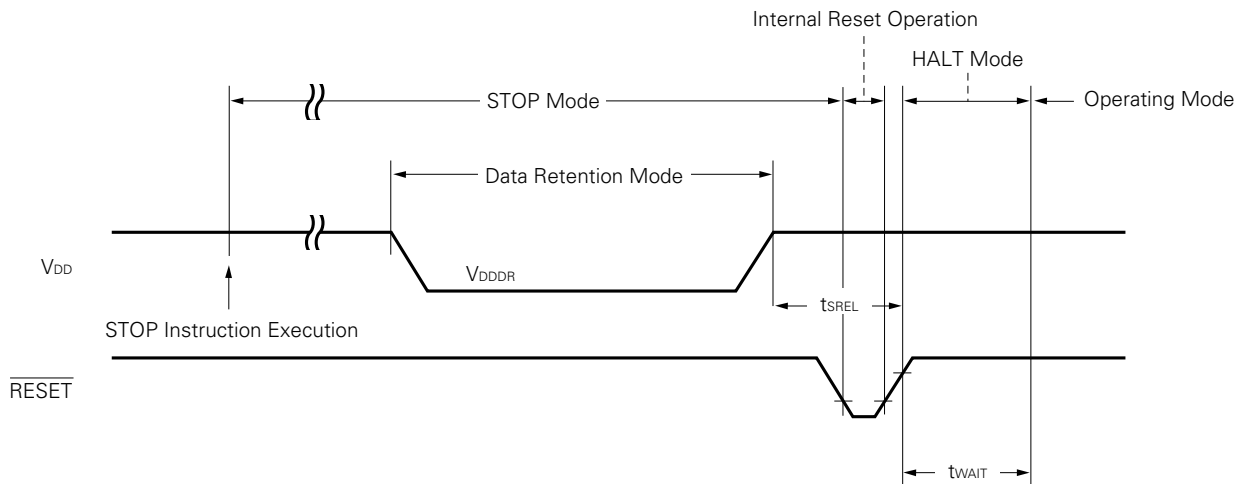

Data Retention Timing (STOP mode release by standby release signal: interrupt signal)

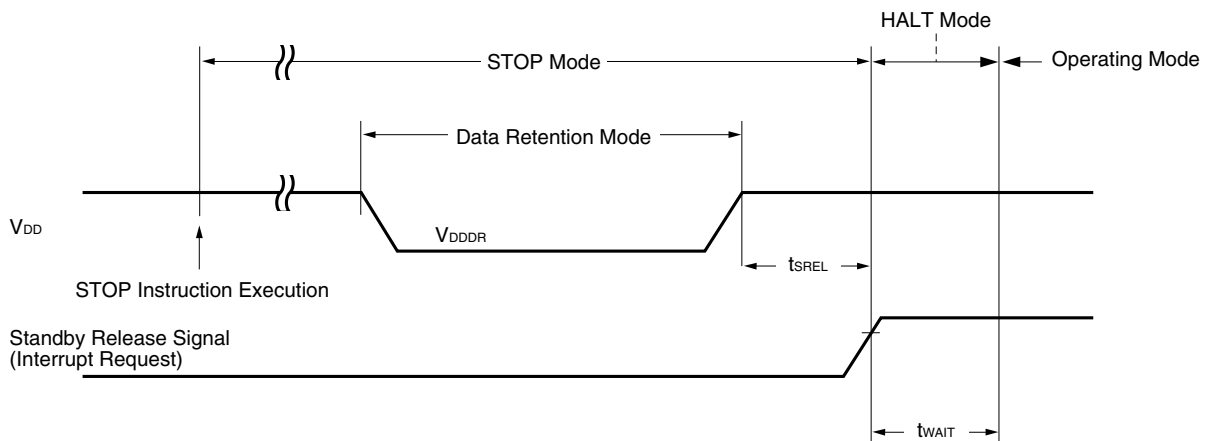

Interrupt Input Timing

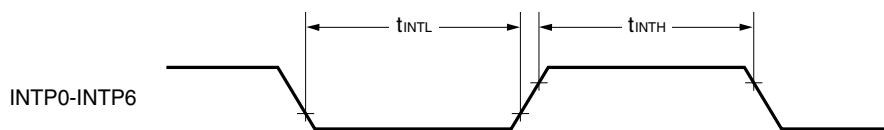

RESET Input Timing

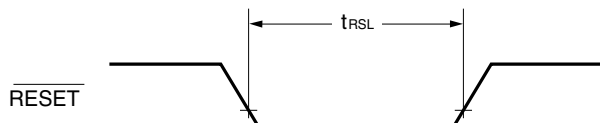

IEBus Controller Characteristics (T_A = -40 to +85°C, V_{DD} = 5 V ± 10%)

Parameter	Symbol	Conditions	MIN.	TYP.	MAX.	Unit
IEBus controller system clock frequency	fs	When using mode 0, 1 ^{Note 1}	5.91	6.00	6.09	MHz
			6.20	6.29	6.39	MHz
		When using mode 2	5.97	6.00	6.03	MHz
			6.26	6.29	6.32	MHz
Driver delay time (\overline{TX} output → bus line)		C = 50 pF ^{Note 2} fs = 6.00 MHz			1.6	μs
		fs = 6.29 MHz			1.5	μs
Receiver delay time (Bus line → \overline{RX} input)		fs = 6.00 MHz			0.75	μs
		fs = 6.29 MHz			0.7	μs
Propagation delay time on the bus		fs = 6.00 MHz			0.9	μs
		fs = 6.29 MHz			0.85	μs

Notes 1. For the values in the second row, the IEBus standards are not satisfied.

2. C is the \overline{TX} output line load capacitance.

PROM PROGRAMMING CHARACTERISTICS

DC Characteristics

(1) PROM Write Mode ($T_A = 25 \pm 5^\circ\text{C}$, $V_{DD} = 6.5 \pm 0.25\text{ V}$, $V_{PP} = 12.5 \pm 0.3\text{ V}$)

Parameter	Symbol	Test Conditions	MIN.	TYP.	MAX.	Unit
Input voltage high	V_{IH}		$0.7 V_{DD}$		V_{DD}	V
Input voltage low	V_{IL}		0		$0.3 V_{DD}$	V
Output voltage high	V_{OH}	$I_{OH} = -1\text{ mA}$	$V_{DD} - 1.0$			V
Output voltage low	V_{OL}	$I_{OL} = 1.6\text{ mA}$			0.4	V
Input leakage current	I_{LI}	$0 \leq V_{IN} \leq V_{DD}$	-10		+10	μA
V_{PP} supply voltage	V_{PP}		12.2	12.5	12.8	V
V_{DD} supply voltage	V_{DD}		6.25	6.5	6.75	V
V_{PP} supply current	I_{PP}	PGM = V_{IL}			50	mA
V_{DD} supply current	I_{DD}				50	mA

(2) PROM Read Mode ($T_A = 25 \pm 5^\circ\text{C}$, $V_{DD} = 5.0 \pm 0.5\text{ V}$, $V_{PP} = V_{DD} \pm 0.6\text{ V}$)

Parameter	Symbol	Test Conditions	MIN.	TYP.	MAX.	Unit
Input voltage high	V_{IH}		$0.7 V_{DD}$		V_{DD}	V
Input voltage low	V_{IL}		0		$0.3 V_{DD}$	V
Output voltage high	V_{OH1}	$I_{OH} = -1\text{ mA}$	$V_{DD} - 1.0$			V
	V_{OH2}	$I_{OH} = -100\ \mu\text{A}$	$V_{DD} - 0.5$			V
Output voltage low	V_{OL}	$I_{OL} = 1.6\text{ mA}$			0.4	V
Input leakage current	I_{LI}	$0 \leq V_{IN} \leq V_{DD}$	-10		+10	μA
Output leakage current	I_{LO}	$0 \leq V_{OUT} \leq V_{DD}$, $\overline{OE} = V_{IH}$	-10		+10	μA
V_{PP} supply voltage	V_{PP}		$V_{DD} - 0.6$	V_{DD}	$V_{DD} + 0.6$	V
V_{DD} supply voltage	V_{DD}		4.5	5.0	5.5	V
V_{PP} supply current	I_{PP}	$V_{PP} = V_{DD}$			100	μA
V_{DD} supply current	I_{DD}	$\overline{CE} = V_{IL}$, $V_{IN} = V_{IH}$			50	mA

AC Characteristics

(1) PROM Write Mode

(a) Page program mode ($T_A = 25 \pm 5^\circ\text{C}$, $V_{DD} = 6.5 \pm 0.25\text{ V}$, $V_{PP} = 12.5 \pm 0.3\text{ V}$)

Parameter	Symbol	Test Conditions	MIN.	TYP.	MAX.	Unit
Address setup time (vs. $\overline{\text{OE}}\downarrow$)	t_{AS}		2			μs
$\overline{\text{OE}}$ setup time	t_{OES}		2			μs
CE setup time (vs. $\overline{\text{OE}}\downarrow$)	t_{CES}		2			μs
Input data setup time (vs. $\overline{\text{OE}}\downarrow$)	t_{DS}		2			μs
Address hold time (vs. $\overline{\text{OE}}\uparrow$)	t_{AH}		2			μs
	t_{AHL}		2			μs
	t_{AHV}		0			μs
Input data hold time (vs. $\overline{\text{OE}}\uparrow$)	t_{DH}		2			μs
Data output float delay time from $\overline{\text{OE}}\uparrow$	t_{DF}		0		250	ns
V_{PP} setup time (vs. $\overline{\text{OE}}\downarrow$)	t_{VPS}		1.0			ms
V_{DD} setup time (vs. $\overline{\text{OE}}\downarrow$)	t_{VDS}		1.0			ms
Program pulse width	t_{PW}		0.095		0.105	ms
Valid data delay time from $\overline{\text{OE}}\downarrow$	t_{OE}				1	μs
$\overline{\text{OE}}$ pulse width during data latching	t_{LW}		1			μs
$\overline{\text{PGM}}$ setup time	t_{PGMS}		2			μs
$\overline{\text{CE}}$ hold time	t_{CEH}		2			μs
$\overline{\text{OE}}$ hold time	t_{OEH}		2			μs

(b) Byte program mode ($T_A = 25 \pm 5^\circ\text{C}$, $V_{DD} = 6.5 \pm 0.25\text{ V}$, $V_{PP} = 12.5 \pm 0.3\text{ V}$)

Parameter	Symbol	Test Conditions	MIN.	TYP.	MAX.	Unit
Address setup time (vs. $\overline{\text{PGM}}\downarrow$)	t_{AS}		2			μs
$\overline{\text{OE}}$ setup time	t_{OES}		2			μs
$\overline{\text{CE}}$ setup time (vs. $\overline{\text{PGM}}\downarrow$)	t_{CES}		2			μs
Input data setup time (vs. $\overline{\text{PGM}}\downarrow$)	t_{DS}		2			μs
Address hold time (vs. $\overline{\text{OE}}\uparrow$)	t_{AH}		2			μs
Input data hold time (vs. $\overline{\text{PGM}}\uparrow$)	t_{DH}		2			μs
Data output float delay time from $\overline{\text{OE}}\uparrow$	t_{DF}		0		250	ns
V_{PP} setup time (vs. $\overline{\text{PGM}}\downarrow$)	t_{VPS}		1.0			ms
V_{DD} setup time (vs. $\overline{\text{PGM}}\downarrow$)	t_{VDS}		1.0			ms
Program pulse width	t_{PW}		0.095		0.105	ms
Valid data delay time from $\overline{\text{OE}}\downarrow$	t_{OE}				1	μs
$\overline{\text{OE}}$ hold time	t_{OEH}		2			μs

(2) PROM Read Mode ($T_A = 25 \pm 5^\circ\text{C}$, $V_{DD} = 5.0 \pm 0.5\text{ V}$, $V_{PP} = V_{DD} \pm 0.6\text{ V}$)

Parameter	Symbol	Test Conditions	MIN.	TYP.	MAX.	Unit
Data output delay time from address	t_{ACC}	$\overline{CE} = \overline{OE} = V_{IL}$			800	ns
Data output delay time from $\overline{CE}\downarrow$	t_{CE}	$\overline{OE} = V_{IL}$			800	ns
Data output delay time from $\overline{OE}\downarrow$	t_{OE}	$\overline{CE} = V_{IL}$			200	ns
Data output float delay time from $\overline{OE}\uparrow$	t_{DF}	$\overline{CE} = V_{IL}$	0		60	ns
Data hold time from address	t_{OH}	$\overline{CE} = \overline{OE} = V_{IL}$	0			ns

(3) PROM Programming Mode Setting ($T_A = 25^\circ\text{C}$, $V_{SS} = 0\text{ V}$)

Parameter	Symbol	Test Conditions	MIN.	TYP.	MAX.	Unit
PROM programming mode setup time	t_{SMA}		10			μs

PROM Write Mode Timing (page program mode)

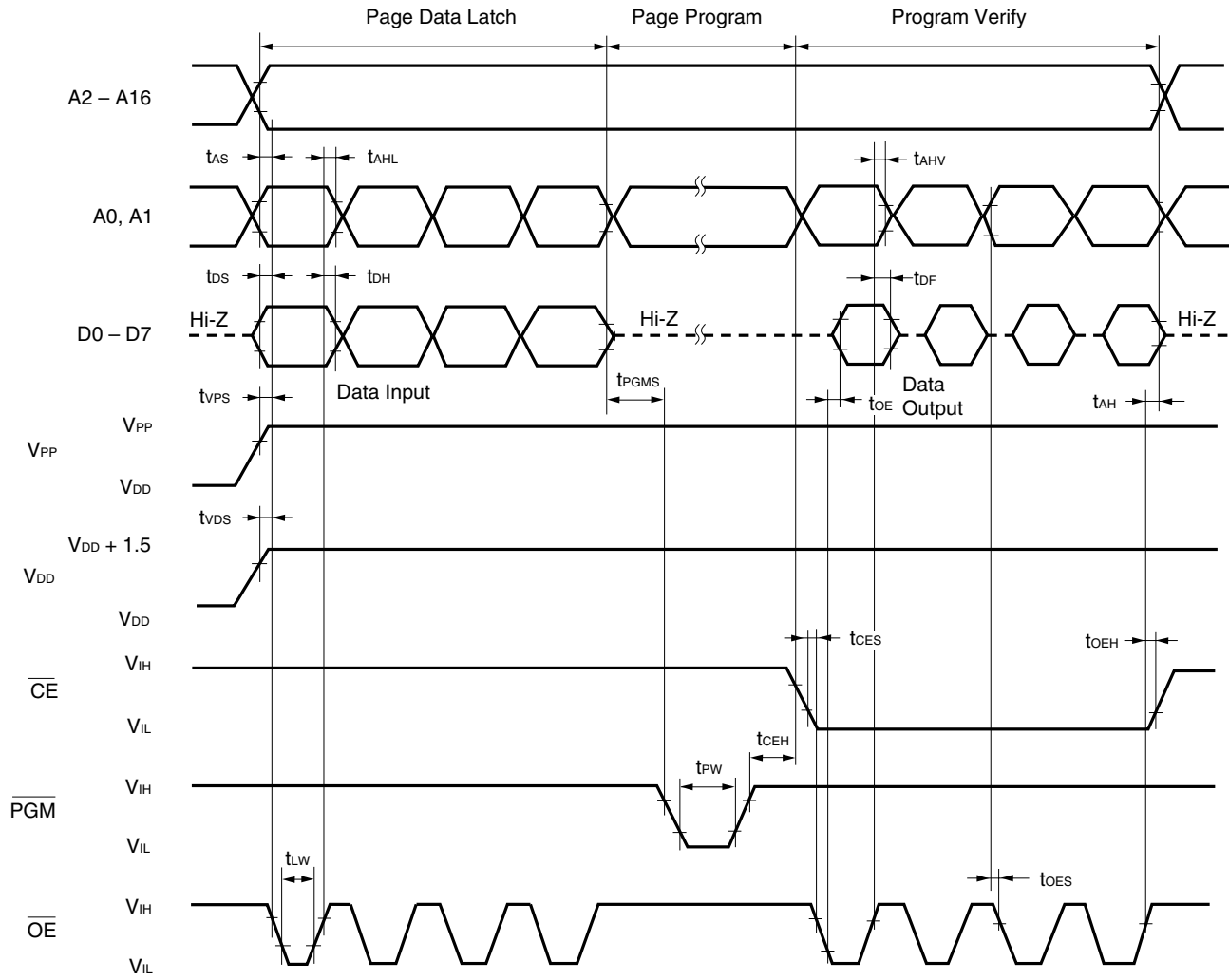

PROM Write Mode Timing (byte program mode)

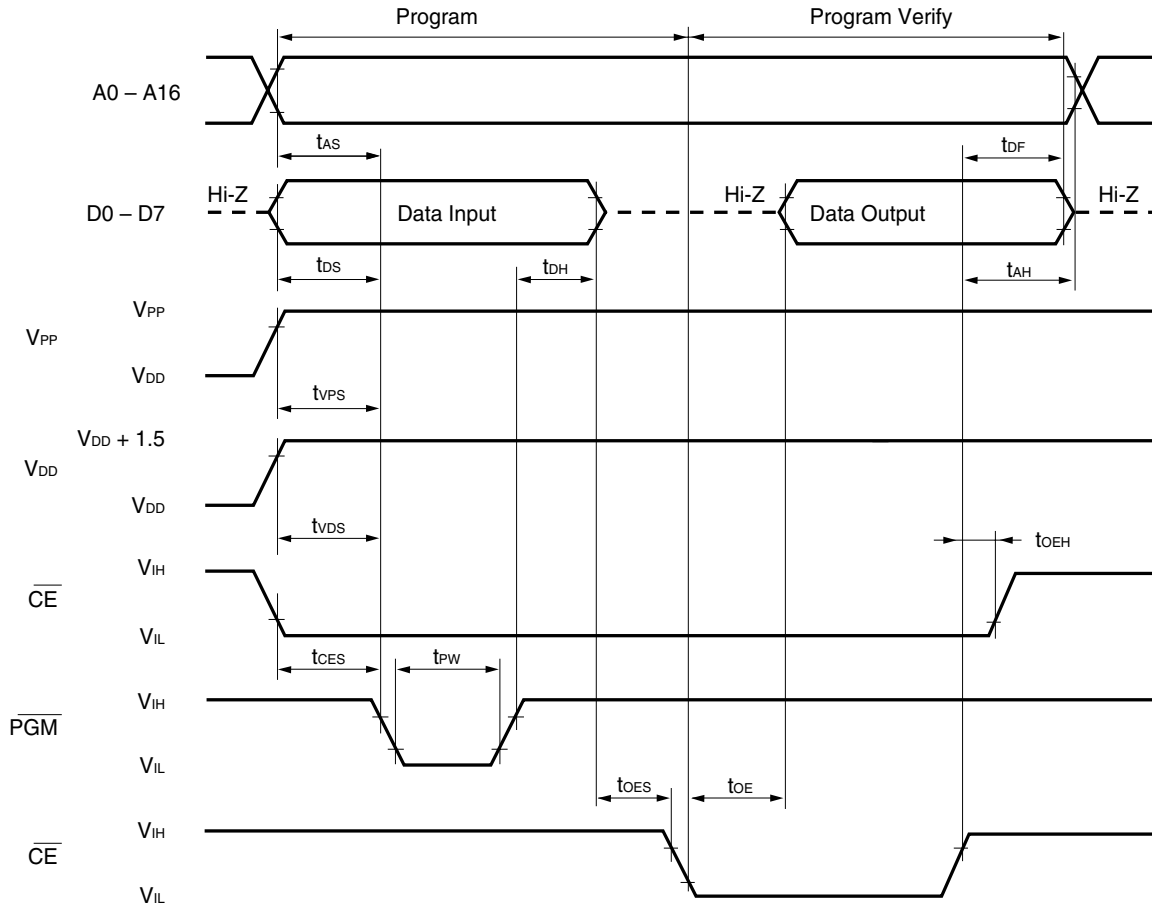

- Cautions**
1. V_{DD} should be applied before V_{PP} , and cut after V_{PP} .
 2. V_{PP} should not exceed +13.5 V including overshoot.
 3. Disconnection during application of $\pm 12.5V$ to V_{PP} may have an adverse effect on reliability.

PROM Read Mode Timing

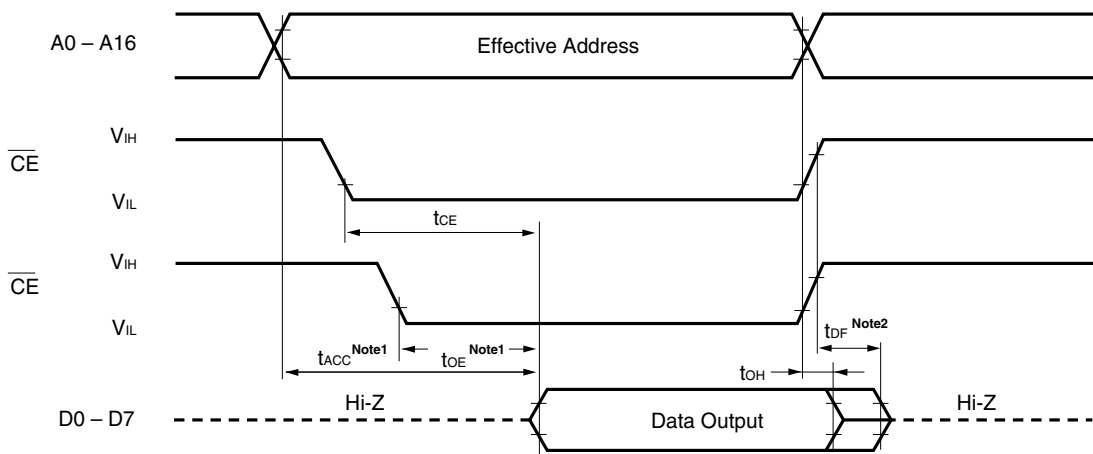

- Notes**
1. If you want to read within the t_{ACC} range, make the \overline{OE} input delay time from the fall of \overline{CE} a maximum of $t_{ACC} - t_{OE}$.
 2. t_{DF} is the time from when either \overline{OE} or \overline{CE} first reaches V_{IH} .

PROM Programming Mode Setting Timing

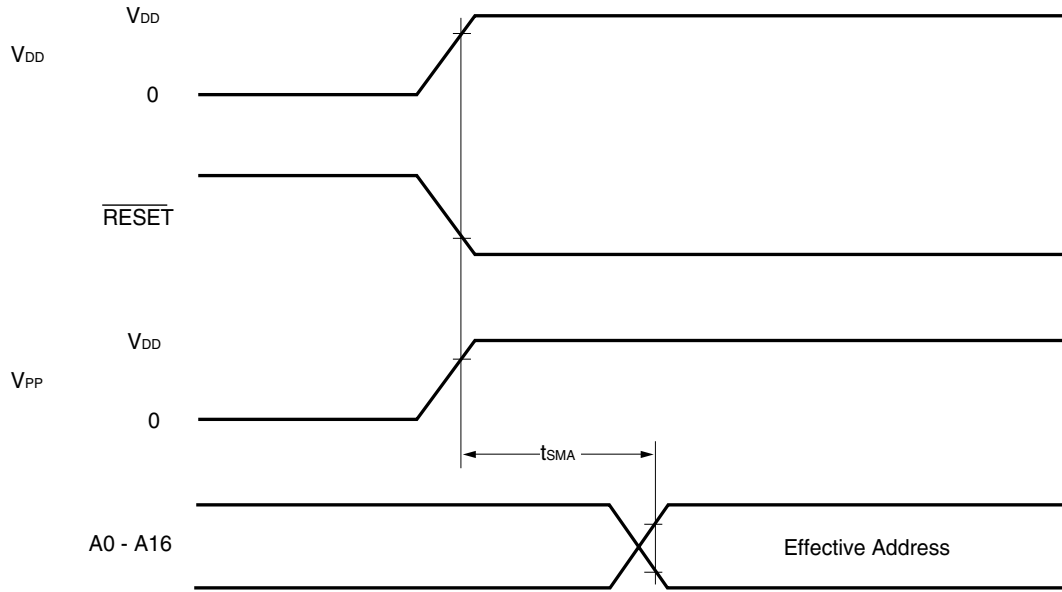

8. PACKAGE DRAWINGS

★ 80-PIN PLASTIC QFP (14x14)

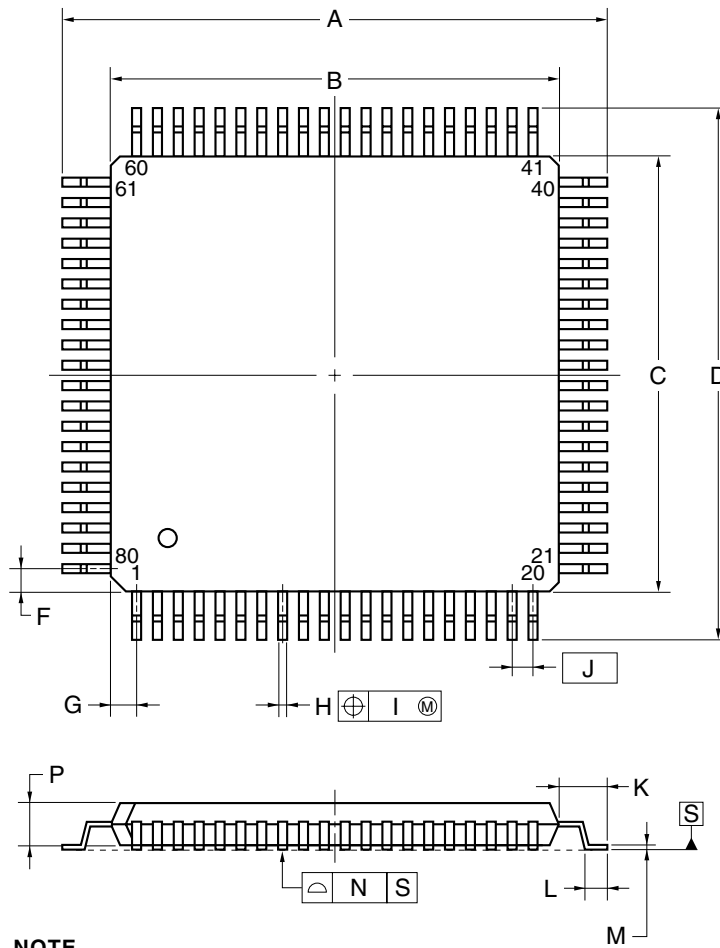

detail of lead end

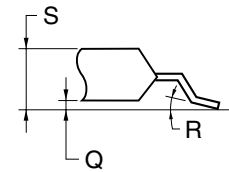

NOTE

Each lead centerline is located within 0.13 mm of its true position (T.P.) at maximum material condition.

ITEM	MILLIMETERS
A	17.20±0.20
B	14.00±0.20
C	14.00±0.20
D	17.20±0.20
F	0.825
G	0.825
H	0.32±0.06
I	0.13
J	0.65 (T.P.)
K	1.60±0.20
L	0.80±0.20
M	0.17 ^{+0.03} _{-0.07}
N	0.10
P	1.40±0.10
Q	0.125±0.075
R	3° ^{+7°} _{-3°}
S	1.70 MAX.

P80GC-65-8BT-1

★ 9. RECOMMENDED SOLDERING CONDITIONS

These products should be soldered and mounted under the following recommended conditions.

For the details of the recommended soldering conditions, refer to the document **Semiconductor Device Mounting Technology Manual (C10535E)**.

For soldering methods and conditions other than those recommended below, please contact your NEC sales representative.

Table 9-1. Surface Mount Type Soldering Conditions

μPD78P098AGC-8BT : 80-pin plastic QFP (14 x 14)

Soldering Method	Soldering Conditions	Recommended Condition Symbol
Infrared reflow	Package peak temperature: 235°C, Time: 30 seconds max. (at 210°C or higher), Count: 2 times or less, Exposure limit: 7 days ^{Note} (after that, prebake at 125°C for 10 hours)	IR35-107-2
VPS	Package peak temperature: 215°C, Time: 40 seconds max. (at 200°C or higher), Count: 2 times or less, Exposure limit: 7 days ^{Note} (after that, prebake at 125°C for 10 hours)	VP15-107-2
Wave soldering	Solder bath temperature: 260°C max., Time: 10 seconds max., Count: Once, Preheating temperature: 120°C max. (package surface temperature), Exposure limit: 7 days ^{Note} (after that, prebake at 125°C for 10 hours)	WS60-107-1
Partial heating	Pin temperature: 300°C max., Time: 3 seconds max. (per pin row)	—

Note After opening the dry pack, store it at 25°C or less and 65% RH or less for the allowable storage period.

Caution Do not use different soldering methods together (except for partial heating).

APPENDIX A. DEVELOPMENT TOOLS

The following development tools are available for development of systems using the μPD78P098A.
Also refer to (6) **Notes on using development tools.**

★ (1) **Software package**

SP78K0	Software package common to 78K/0 Series
--------	---

(2) **Language processor software**

RA78K0	Common assembler package for 78K/0 series products
CC78K0	Common C compiler package for 78K/0 series products
DF78098	Device file for μPD78098 subseries
CC78K0-L	Common C compiler library source file for 78K/0 series products

(3) **PROM writing tools**

PG-1500	PROM programmer
PA-78P054GC	Programmer adapter connected to PG-1500
PG-1500 controller	Control program for PG-1500

★ (4) **Debugging tools**

IE-78001-R-A	In-circuit emulator common to 78K/0 Series
IE-70000-98-IF-C	Adapter required when PC-9800 series (except notebook type) is used as host machine (C bus supported)
IE-70000-PC-IF-C	Adapter required when IBM PC/AT compatible is used as host machine (ISA bus supported)
IE-70000-PCI-IF-A	Adapter required when PC incorporating PCI bus is used as host machine
IE-70000-R-SV3	Interface adapter and cable required when EWS is used as host machine
IE-78098-R-EM	Emulation board to emulate the μPD78098 Subseries
EP-78230GC-R	Emulation probe for 80-pin plastic QFP (GC-8BT type)
EV-9200GC-80	Conversion socket to connect the EP-78230GC-R and the target system board on which 80-pin plastic QFP (GC-8BT type) can be mounted
ID78K0	Integrated debugger for IE-78001-R-A
SM78K0	System simulator common to 78K/0 Series
DF78098	Device file for μPD78098 Subseries

(5) **Real-time OS**

RX78K/0	Real-time OS for 78K/0 series
MX78K0	OS for 78K/0 series

★ (6) Notes on using development tools

- The ID78K0, and SM78K0 are used in combination with the DF78098.
- The CC78K0 and RX78K0 are used in combination with the RA78K0 and DF78098.
- For third-party development tools, see the **Single-Chip Microcontroller Development Tool Selection Guide (U11069E)**.
- The host machines and OS suitable for each software are as follows:

Host Machine [OS] Software	PC	EWS
	PC-9800 series [Japanese Windows™] IBM PC/AT compatibles [Japanese/English Windows]	HP9000 series 700™ [HP-UX™] SPARCstation™ [SunOS™, Solaris™]
RA78K0	√ Note	√
CC78K0	√ Note	√
ID78K0	√	—
SM78K0	√	—
RX78K0	√ Note	√
MX78K0	√ Note	√

Note DOS-based software

DIMENSIONS AND RECOMMENDED MOUNTING PATTERN OF CONVERSION SOCKET

Figure A-1. Dimensions of EV-9200GC-80 (reference)

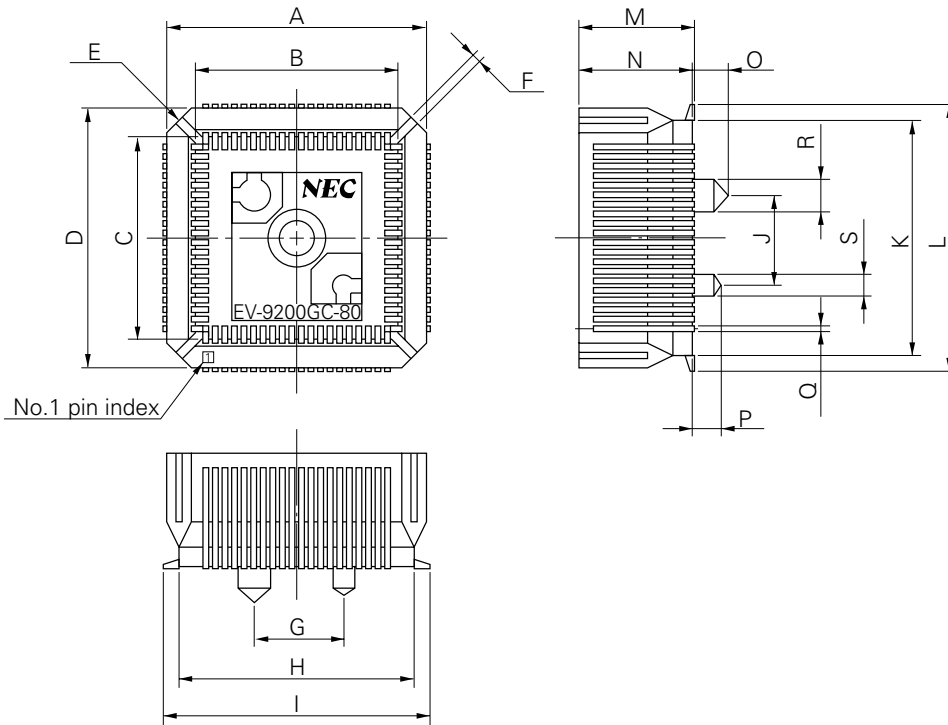

EV-9200GC-80-G0

ITEM	MILLIMETERS	INCHES
A	18.0	0.709
B	14.4	0.567
C	14.4	0.567
D	18.0	0.709
E	4-C 2.0	4-C 0.079
F	0.8	0.031
G	6.0	0.236
H	16.0	0.63
I	18.7	0.736
J	6.0	0.236
K	16.0	0.63
L	18.7	0.736
M	8.2	0.323
O	8.0	0.315
N	2.5	0.098
P	2.0	0.079
Q	0.35	0.014
R	φ2.3	φ0.091
S	φ1.5	φ0.059

Figure A-2. Recommended Mounting Pattern of EV-9200GC-80 (reference)

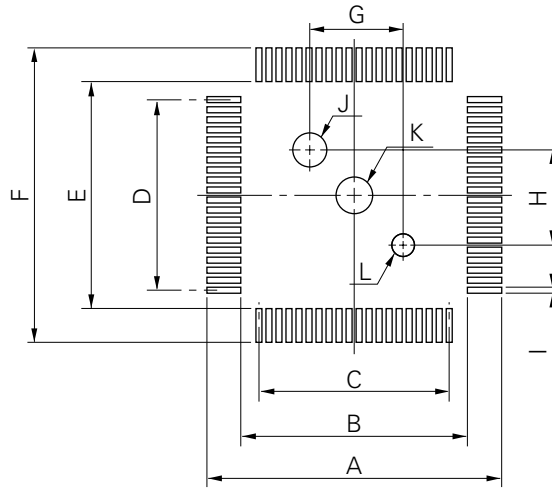

EV-9200GC-80-P0

ITEM	MILLIMETERS	INCHES
A	19.7	0.776
B	15.0	0.591
C	$0.65 \pm 0.02 \times 19 = 12.35 \pm 0.05$	$0.026^{+0.001}_{-0.002} \times 0.748 = 0.486^{+0.003}_{-0.002}$
D	$0.65 \pm 0.02 \times 19 = 12.35 \pm 0.05$	$0.026^{+0.001}_{-0.002} \times 0.748 = 0.486^{+0.003}_{-0.002}$
E	15.0	0.591
F	19.7	0.776
G	6.0 ± 0.05	$0.236^{+0.003}_{-0.002}$
H	6.0 ± 0.05	$0.236^{+0.003}_{-0.002}$
I	0.35 ± 0.02	$0.014^{+0.001}_{-0.001}$
J	$\phi 2.36 \pm 0.03$	$\phi 0.093^{+0.001}_{-0.002}$
K	$\phi 2.3$	$\phi 0.091$
L	$\phi 1.57 \pm 0.03$	$\phi 0.062^{+0.001}_{-0.002}$

Caution Dimensions of mount pad for EV-9200 and that for target device (QFP) may be different in some parts. For the recommended mount pad dimensions for QFP, refer to "SEMICONDUCTOR DEVICE MOUNTING TECHNOLOGY MANUAL" (C10535E).

★ **APPENDIX B. RELATED DOCUMENTS**

The related documents indicated in this publication may include preliminary versions. However, preliminary versions are not marked as such.

Documents Related to Devices

Document Name	Document No.
μPD78098 Subseries User's Manual	IEU-1381
μPD78094, 78095, 78096, 78098A Data Sheet	U10146E
μPD78P098A Data Sheet	This manual
78K/0 Series User's Manual - Instruction	U12326E
78K/0 Series Application Note - Basic(III)	U10182E

Documents Related to Development Software Tools (User's Manuals)

Document Name	Document No.	
RA78K0 Assembler Package	Operation	U14445E
	Language	U14446E
	Structured Assembly Language	U11789E
CC78K0 C Compiler	Operation	U14297E
	Language	U14298E
SM78K0S, SM78K0 System Simulator Ver. 2.10 or Later Windows Based	Operation	U14611E
SM78K Series System Simulator Ver. 2.10 or Later	External Parts User Open Interface Specification	U15006E
ID78K0-NS Integrated Debugger Ver. 2.00 or Later Windows Based	Operation	U14379E
ID78K0 Integrated Debugger Windows Based	Reference	U11539E
	Guide	U11649E
RX78K0 Real-time OS	Fundamentals	U11537E
	Installation	U11536E
MX78K0 Embedded OS	Fundamental	U12257E

Documents Related to Development Hardware Tools (User's Manuals)

Document Name	Document No.
IE-78001-R-A In-Circuit Emulator	U14142E
IE-78098-R-EM Emulation Board	EEU-1473

Documents Related to PROM Writing (User's Manuals)

Document Name	Document No.	
PG-1500 PROM Programmer	U11940E	
PG-1500 Controller	PC-9800 Series (MS-DOS)-Based	EEU-1291
	IBM PC Series (PC DOS)-Based	U10540E

Other Related Documents

Document Name	Document No.
SEMICONDUCTOR SELECTION GUIDE - Products & Package -	X13769E
Semiconductor Device Mounting Technology Manual	C10535E
Quality Grades on NEC Semiconductor Devices	C11531E
NEC Semiconductor Device Reliability/Quality Control System	C10983E
Guide to Prevent Damage for Semiconductor Devices by Electrostatic Discharge (ESD)	C11892E

Caution The related documents listed above are subject to change without notice. Be sure to use the latest version of each document for designing.

[MEMO]

NOTES FOR CMOS DEVICES**① PRECAUTION AGAINST ESD FOR SEMICONDUCTORS**

Note:

Strong electric field, when exposed to a MOS device, can cause destruction of the gate oxide and ultimately degrade the device operation. Steps must be taken to stop generation of static electricity as much as possible, and quickly dissipate it once, when it has occurred. Environmental control must be adequate. When it is dry, humidifier should be used. It is recommended to avoid using insulators that easily build static electricity. Semiconductor devices must be stored and transported in an anti-static container, static shielding bag or conductive material. All test and measurement tools including work bench and floor should be grounded. The operator should be grounded using wrist strap. Semiconductor devices must not be touched with bare hands. Similar precautions need to be taken for PW boards with semiconductor devices on it.

② HANDLING OF UNUSED INPUT PINS FOR CMOS

Note:

No connection for CMOS device inputs can be cause of malfunction. If no connection is provided to the input pins, it is possible that an internal input level may be generated due to noise, etc., hence causing malfunction. CMOS devices behave differently than Bipolar or NMOS devices. Input levels of CMOS devices must be fixed high or low by using a pull-up or pull-down circuitry. Each unused pin should be connected to V_{DD} or GND with a resistor, if it is considered to have a possibility of being an output pin. All handling related to the unused pins must be judged device by device and related specifications governing the devices.

③ STATUS BEFORE INITIALIZATION OF MOS DEVICES

Note:

Power-on does not necessarily define initial status of MOS device. Production process of MOS does not define the initial operation status of the device. Immediately after the power source is turned ON, the devices with reset function have not yet been initialized. Hence, power-on does not guarantee out-pin levels, I/O settings or contents of registers. Device is not initialized until the reset signal is received. Reset operation must be executed immediately after power-on for devices having reset function.

FIP, IEBus and QTOP are trademarks of NEC Corporation.

Windows is either a registered trademark or trademark of Microsoft Corporation in the United States and/or other countries.

PC/AT is a trademark of International Business Machines Corporation.

HP9000 series 700 and HP-UX are trademarks of Hewlett-Packard Company.

SPARCstation is a trademark of SPARC International, Inc.

Solaris and SunOS are trademarks of Sun Microsystems, Inc.

Regional Information

Some information contained in this document may vary from country to country. Before using any NEC product in your application, please contact the NEC office in your country to obtain a list of authorized representatives and distributors. They will verify:

- Device availability
- Ordering information
- Product release schedule
- Availability of related technical literature
- Development environment specifications (for example, specifications for third-party tools and components, host computers, power plugs, AC supply voltages, and so forth)
- Network requirements

In addition, trademarks, registered trademarks, export restrictions, and other legal issues may also vary from country to country.

NEC Electronics Inc. (U.S.)

Santa Clara, California
Tel: 408-588-6000
800-366-9782
Fax: 408-588-6130
800-729-9288

NEC Electronics (Germany) GmbH

Duesseldorf, Germany
Tel: 0211-65 03 02
Fax: 0211-65 03 490

NEC Electronics (UK) Ltd.

Milton Keynes, UK
Tel: 01908-691-133
Fax: 01908-670-290

NEC Electronics Italiana s.r.l.

Milano, Italy
Tel: 02-66 75 41
Fax: 02-66 75 42 99

NEC Electronics (Germany) GmbH

Benelux Office
Eindhoven, The Netherlands
Tel: 040-2445845
Fax: 040-2444580

NEC Electronics (France) S.A.

Velizy-Villacoublay, France
Tel: 01-3067-5800
Fax: 01-3067-5899

NEC Electronics (France) S.A.

Madrid Office
Madrid, Spain
Tel: 091-504-2787
Fax: 091-504-2860

NEC Electronics (Germany) GmbH

Scandinavia Office
Taeby, Sweden
Tel: 08-63 80 820
Fax: 08-63 80 388

NEC Electronics Hong Kong Ltd.

Hong Kong
Tel: 2886-9318
Fax: 2886-9022/9044

NEC Electronics Hong Kong Ltd.

Seoul Branch
Seoul, Korea
Tel: 02-528-0303
Fax: 02-528-4411

NEC Electronics Singapore Pte. Ltd.

Novena Square, Singapore
Tel: 253-8311
Fax: 250-3583

NEC Electronics Taiwan Ltd.

Taipei, Taiwan
Tel: 02-2719-2377
Fax: 02-2719-5951

NEC do Brasil S.A.

Electron Devices Division
Guarulhos-SP, Brasil
Tel: 11-6462-6810
Fax: 11-6462-6829

J01.2