

Marketing Information D 251 N

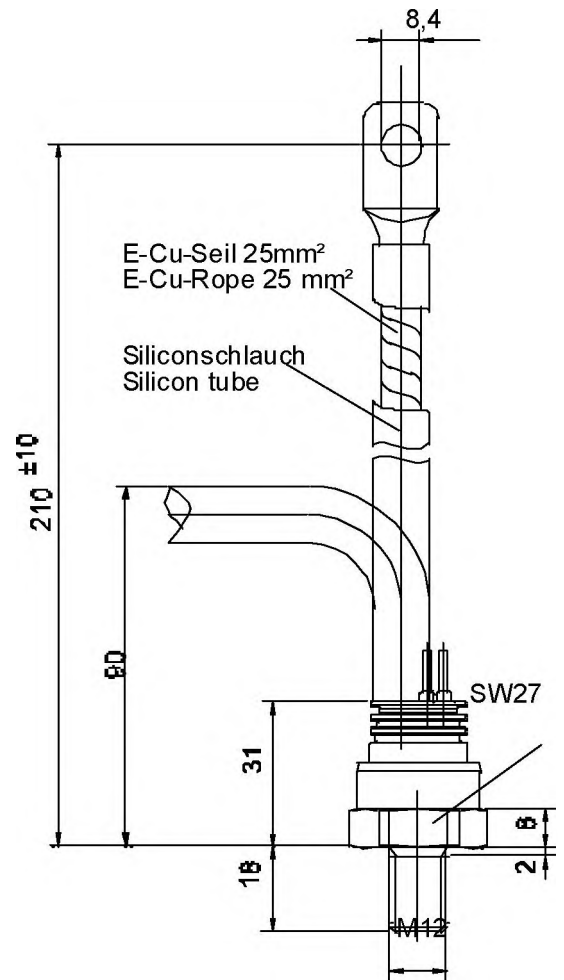
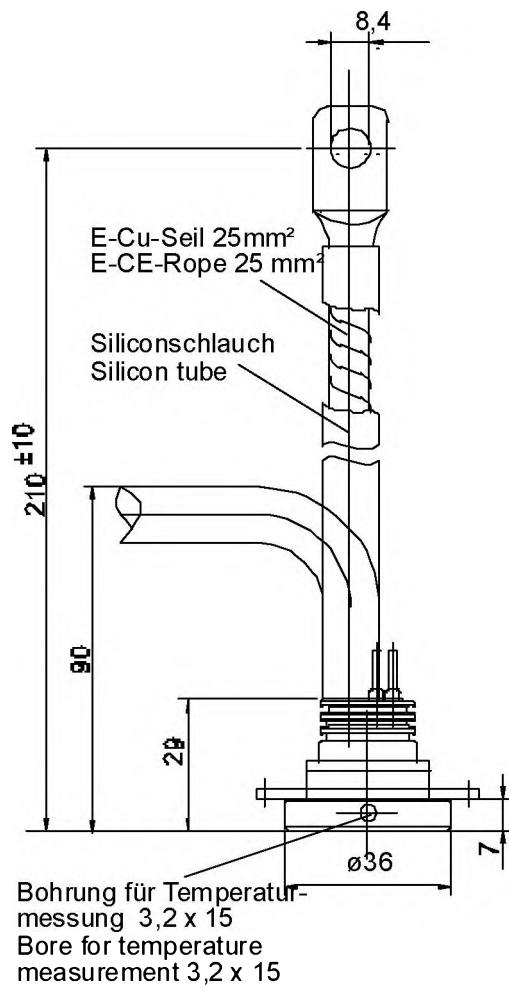

Typ Type	Schalt-symbol Circuit symbol	Kathode Cathode	Anode Anode	Schutzschlauch Prot. flex. tubing
N		Seil Rope	Gehäuse Case	rot red
K		Gehäuse Case	Seil Rope	blau blue

Typ Type	Schalt-symbol Circuit symbol	Kathode Cathode	Anode Anode	Schutzschlauch Prot. flex. tubing
N		Seil Rope	Gewinde Thread	rot red
K		Gewinde Thread	Seil Rope	blau blue

D 251 N

Elektrische Eigenschaften

Electrical properties

Höchstzulässige Werte

Maximum rated values

Periodische Spitzensperrspannung	repetitive peak reverse voltage	$t_{vj} = -40^{\circ}\text{C} \dots t_{vj\text{ max}}$	V_{RRM}	800, 1200, 1400 1800, 2000	V V
Stoßspitzensperrspannung	non-repetitive peak reverse voltage	$t_{vj} = +25^{\circ}\text{C} \dots t_{vj\text{ max}}$	$V_{RSM} = V_{RRM}$	+ 100	V
Durchlaßstrom-Grenzeffektivwert	RMS forward current		I_{FRMSM}	400	A
Dauergrenzstrom	mean forward current	$t_c = 130^{\circ}\text{C}$ $t_c = 129^{\circ}\text{C}$	I_{FAVM}	250 255	A A
Stoßstrom-Grenzwert	surge forward current	$t_{vj} = 25^{\circ}\text{C}, t_p = 10\text{ ms}$ $t_{vj} = t_{vj\text{ max}}, t_p = 10\text{ ms}$	I_{FSM}	6,3 5,3	kA kA
Grenzlastintegral	I^2t -value	$t_{vj} = 25^{\circ}\text{C}, t_p = 10\text{ ms}$ $t_{vj} = t_{vj\text{ max}}, t_p = 10\text{ ms}$	I^2t	198,5 140,5	kA^2s kA^2s

Charakteristische Werte

Characteristic values

Durchlaßspannung	on-state voltage	$t_{vj} = t_{vj\text{ max}}, I_F = 800\text{ A}$	V_T	max.	1,57	V
Schleusenspannung	threshold voltage	$t_{vj} = t_{vj\text{ max}}$	$V_{T(TO)}$		0,8	V
Ersatzwiderstand	slope resistance	$t_{vj} = t_{vj\text{ max}}$	r_T		0,85	$\text{m}\Omega$
Sperrstrom	reverse current	$t_{vj} = t_{vj\text{ max}}, V_R = V_{RRM}$	I_R	max.	30	mA

Thermische Eigenschaften

Thermal properties

Innerer Widerstand	thermal resistance, junction	$\Theta = 180^{\circ}\text{ sin}$	R_{thJC}	max.	0,151	$^{\circ}\text{C}/\text{W}$
	to case	DC		max.	0,145	$^{\circ}\text{C}/\text{W}$
Übergangs-Wärmewiderstand	thermal resistance, case to heatsink		R_{thCK}	max.	0,04	$^{\circ}\text{C}/\text{W}$
Höchstzul. Sperrschichttemperatur	max. junction temperature		$t_{vj\text{ max}}$		180	$^{\circ}\text{C}$
Betriebstemperatur	operating temperature		$t_{c\text{ op}}$		-40...+180	$^{\circ}\text{C}$
Lagertemperatur	storage temperature		t_{stg}		-40...+180	$^{\circ}\text{C}$

Mechanische Eigenschaften

Mechanical properties

Si-Element mit Druckkontakt	Si-pellet with pressure contact	$\varnothing = 21\text{ mm } (\varnothing 23\text{ mm})^1$				
Anzugsdrehmoment	tightening torque	Gehäuseform/case design B	M		20	Nm
Anpreßkraft	clamping force	Gehäuseform/case design E	F		3,5	kN
Gewicht	weight		G	typ.	175	g
Kriechstrecke	creepage distance				12	mm
Feuchteklasse	humidity classification	DIN 40040				C
Schwingfestigkeit	vibration resistance	$f = 50\text{ Hz}$			50	m/s^2
Maßbild	outline					Seite/page
Polarität	polarity					Anode=Gehäuse/case

1) Durchmesser 23 mm nur für $V_{RRM} = 2000\text{ V}$
diameter 23 mm only for $V_{RRM} = 2000\text{ V}$

D251N

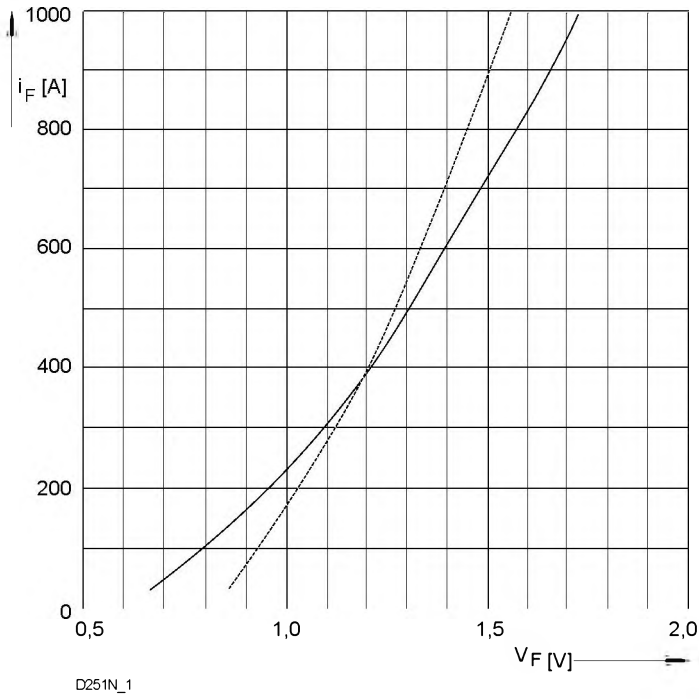

D251N_1

Bild/ Fig. 1
Grenzdurchlaßkennlinie
Limiting forward characteristic $i_F = f(V_F)$
— $t_{vj} = 100\text{ °C}$
- - - $t_{vj} = 25\text{ °C}$

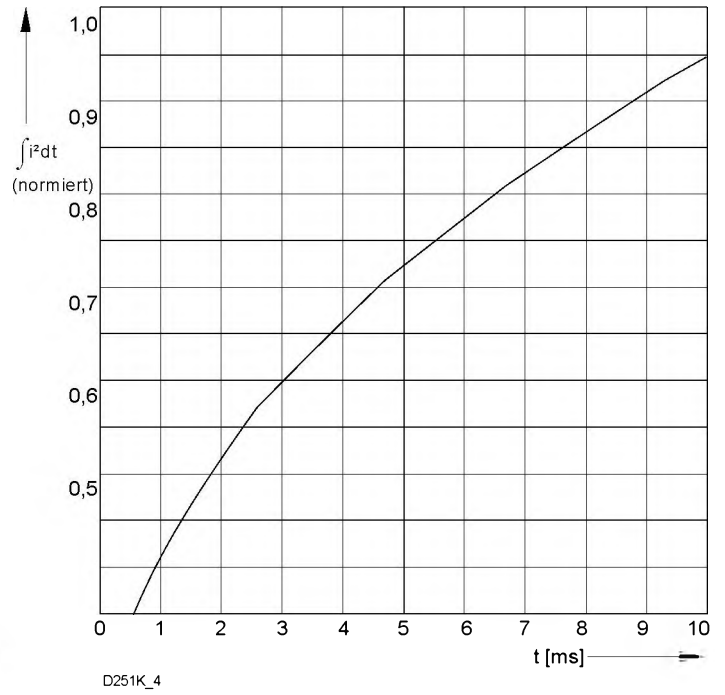

D251K_4

Bild / Fig. 2
Normiertes Grenzlastintegral / Normalized i^2t
 $\int i^2 dt = f(t_e)$

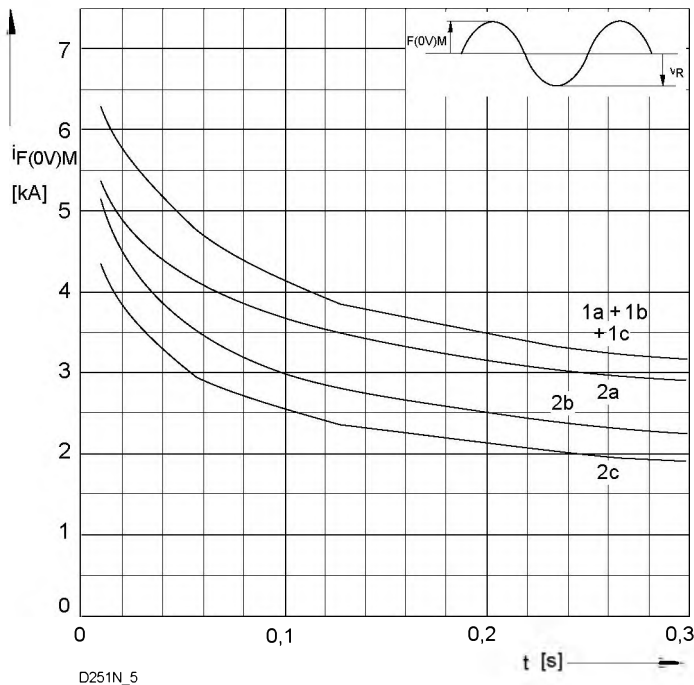

D251N_5

Bild / Fig. 3
Grenzstrom / Maximum overload forward current $I_{F(0V)M} = f(t)$
1 - $I_{FAV(vor)} = 0\text{ A}$; $t_{vj} = t_c = 25\text{ °C}$
2 - $I_{FAV(vor)} = 1\text{ A}$; $t_c = 100\text{ °C}$; $t_{vj} = 100\text{ °C}$
a - $V_R \leq 50\text{ V}$
b - $V_R = V_{RRM}$
c - $V_R = 0,8 V_{RRM}$

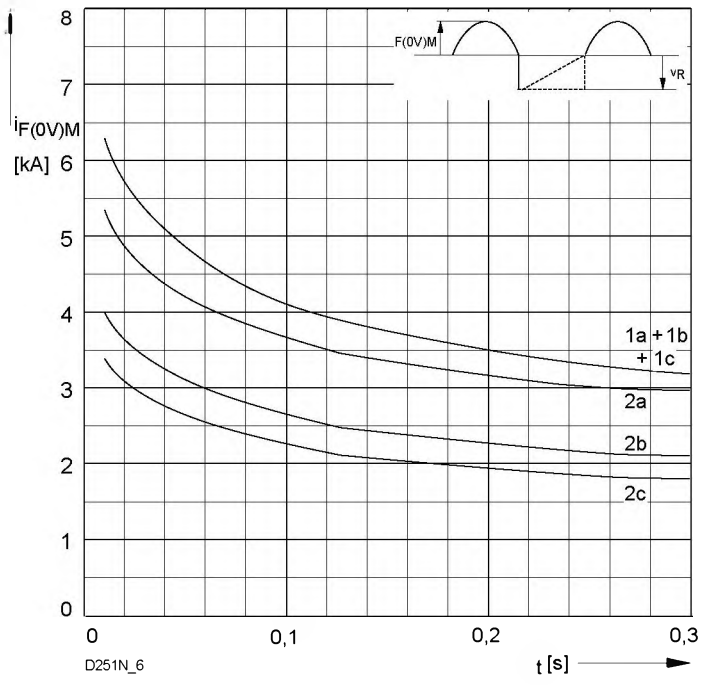

D251N_6

Bild / Fig. 4
Grenzstrom / Maximum overload forward current $I_{F(0V)M} = f(t)$
1 - $I_{FAV(vor)} = 0\text{ A}$; $t_{vj} = t_c = 25\text{ °C}$
2 - $I_{FAV(vor)} = 1\text{ A}$; $t_c = 100\text{ °C}$; $t_{vj} = 100\text{ °C}$
a - $V_R \leq 50\text{ V}$
b - $V_R = 0,5 V_{RRM}$
c - $V_R = 0,8 V_{RRM}$

D251N



Bild / Fig. 5
 Differenz zwischen den Wärmewiderständen für Pulsstrom und DC
 Difference between the values of thermal resistance for pulse current and DC
 Parameter: Stromkurvenform / Current waveform



Bild / Fig. 6
 Sperrverzögerungsladung / Recovered charge $Q_r = f(-di/dt)$
 $t_{vj} = t_{vjmax}$; $V_R \leq 0,5 V_{RRM}$; $V_{RM} = 0,8 V_{RRM}$
 Beschaltung / Snubber: $C = \mu F$; $R = \Omega$
 Parameter: Durchlaßstrom / Forward current I_{FM}

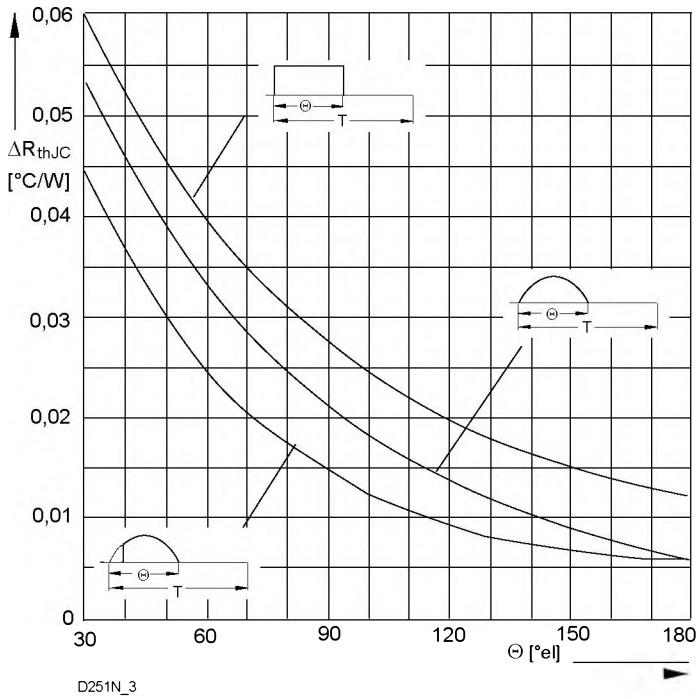

Bild / Fig. 7
 Transienter innerer Wärmewiderstand
 Transient thermal impedance $Z_{thJC} = f(t)$, DC
 1 - Beidseitige Kühlung / Two-sided cooling
 2 - Anodenseitige Kühlung / Anode-sided cooling
 3 - Kathodenseitige Kühlung / Kathode-sided cooling

Analytische Elemente des transienten Wärmewiderstandes Z_{thJC} für DC
 Analytical elements of transient thermal impedance Z_{thJC} for DC

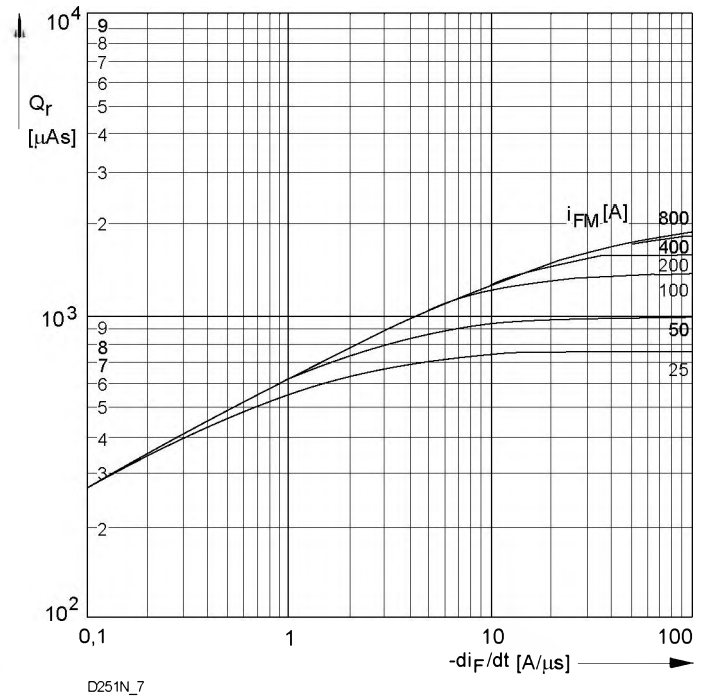
Pos. n	1	2	3	4	5	6	7
R_{thn} °C/W	0,000114	0,003146	0,00934	0,0242	0,0762	0,195	0,112
τ_n [s]	0,000018	0,000282	0,00282	0,0132	0,265	1,2	7,57

Analytische Funktion / Analytical function:

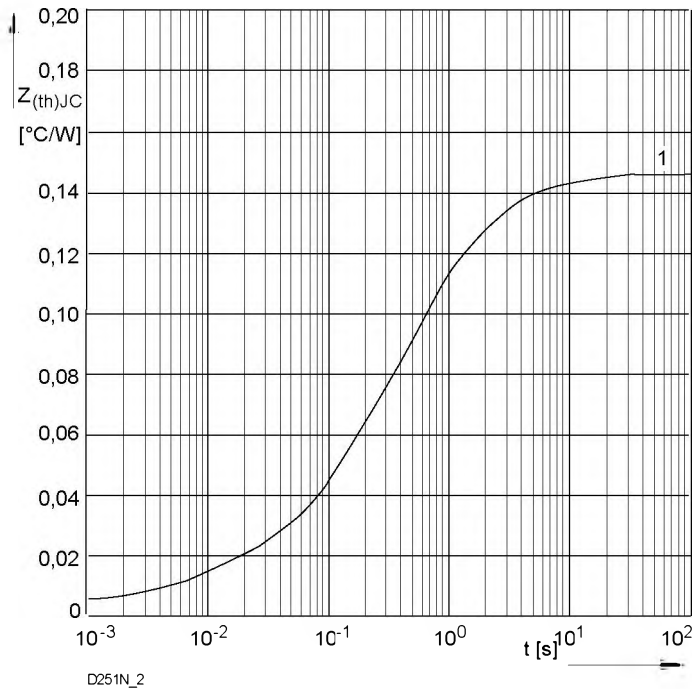
$$Z_{thJC} = \sum_{n=1}^{n_{max}} R_{thn} (1 - \text{EXP}(-t/\tau_n))$$