

SPP-111

SERVICE MANUAL

E Model

Ver 1.0 1999. 10



SPECIFICATIONS

General

Frequency control	Crystal-controlled PLL
Operation mode	FM, duplex
Operation channel	25 channels
Supplied accessories	AC power adaptor AC-T56 (1) Telephone line cord (1) Rechargeable battery pack BP-T16 (1) Screws (2) Directories (2 sheets)

Handset

Power source	Rechargeable battery pack BP-T16
Battery life	Standby: Approx. 14 days Talk: Approx. 6 hours
Dimensions	Approx. 2 3/8 × 7 3/4 × 1 7/8 inches (w/h/d), antenna excluded (approx. 58 × 194 × 47 mm) Antenna: Approx. 4 3/8 inches (approx. 110 mm)
Mass	Approx. 7.8 oz (approx. 220 g), battery included

Base unit

Power source	DC 9V from AC power adaptor
Battery charging time	Approx. 12 hours
Dimensions	Approx. 5 1/4 × 2 1/4 × 8 3/4 inches (w/h/d), antenna excluded (approx. 132 × 56 × 220 mm) Antenna: Approx. 12 1/4 inches (approx. 310 mm)
Mass	Approx. 11 oz (approx. 310 g)

Design and specifications are subject to change without notice.

CORDLESS TELEPHONE

SONY®



TABLE OF CONTENTS

1. GENERAL

Setting up the phone	3
Making and receiving calls	4
Speed dialing	4
Resetting the digital security code	5
Paging	5

2. DISASSEMBLY

2-1. Cabinet (Lower) (Base Unit)	6
2-2. Cabinet (Rear) (Handset)	6

3. TEST MODE

Base Unit Section	7
Handset Section	9

4. ELECTRICAL ADJUSTMENTS

Base Unit Section	12
Handset Section	14

5. DIAGRAMS

5-1. IC Pin Descriptions	16
5-2. Block Diagram –Base Unit Section–	19
5-3. Block Diagram –Handset Section–	21
5-4. Printed Wiring Board –Base Unit Section–	23
5-5. Schematic Diagram –Base Unit Section–	25
5-6. Printed Wiring Board –Handset Section–	27
5-7. Schematic Diagram –Handset Section–	29

6. EXPLODED VIEWS

6-1. Base Unit Section	32
6-2. Handset Section	33

7. ELECTRICAL PARTS LIST

.....	34
-------	----

Notes on Chip Component Replacement

- Never reuse a disconnected chip component.
- Notice that the minus side of a tantalum capacitor may be damaged by heat.

SAFETY-RELATED COMPONENT WARNING!!

COMPONENTS IDENTIFIED BY MARK \triangle OR DOTTED LINE WITH MARK \triangle ON THE SCHEMATIC DIAGRAMS AND IN THE PARTS LIST ARE CRITICAL TO SAFE OPERATION. REPLACE THESE COMPONENTS WITH SONY PARTS WHOSE PART NUMBERS APPEAR AS SHOWN IN THIS MANUAL OR IN SUPPLEMENTS PUBLISHED BY SONY.

SECTION 1 GENERAL

This section is extracted from instruction manual.

Setting up the phone

Caution

The cordless telephone operates at a frequency that may cause interference to nearby TVs and VCRs; the base unit should not be placed near or on the top of a TV or VCR; and, if interference is experienced, moving the cordless telephone farther away from the TV or VCR will often reduce or eliminate the interference.

Connect the base unit

If you want to hang the base unit on the wall, mount the unit first (see "Mounting the base unit on the wall").

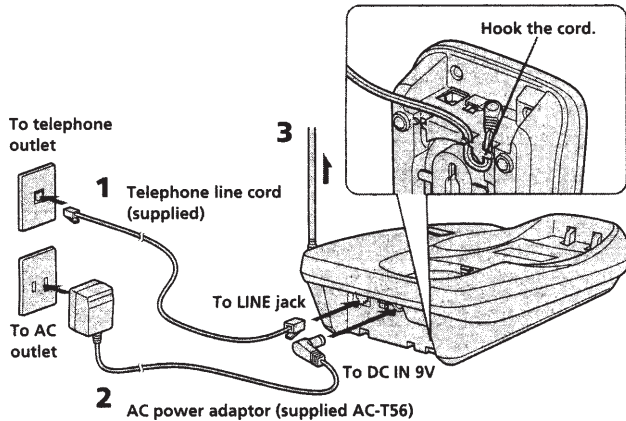

- 1 Connect the telephone line cord to the LINE jack and to a telephone outlet.
- 2 Connect the AC power adaptor to the DC IN 9V jack and to an AC outlet.
- 3 Fully extend the antenna. Make sure it points toward the ceiling.

Notes

- Use only the supplied AC-T56 AC power adaptor. Do not use any other AC power adaptor.
- Connect the AC power adaptor to a continuous power supply.
- Place the base unit close to the AC outlet so that you can unplug the AC power adaptor easily.

Polarity of the plug



Modular



Tip

If your telephone outlet is not modular, contact your telephone service company for assistance.

Choose the dialing mode

For the telephone to work properly, select an appropriate dialing mode (tone or pulse).

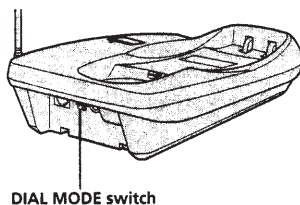

Depending on your dialing system, set the DIAL MODE switch as follows:

If your dialing system is	Set the switch to
Tone	T
Pulse	P

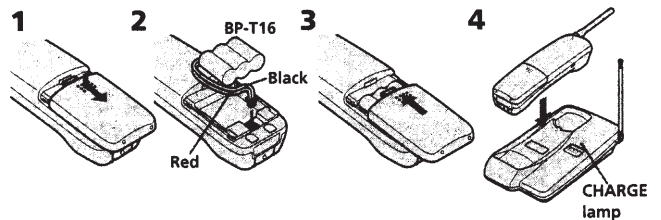

Battery duration

A fully charged battery pack lasts for about:

- 6 hours when you use the handset continuously.
- 14 days when the handset is in standing by.

Notes

- The battery pack will gradually discharge over a long period of time, even if not in use.
- If you leave the battery pack in the handset without charging it, the battery pack will be completely discharged. It may require several times of charging to recover to its full capacity.
- If the battery runs out completely, the speed dial numbers and the digital security code will be erased. If this happens, charge it on the base unit for over 12 hours. Then reprogram the speed dial numbers, and assign a new digital security code (see "Resetting the digital security code"). You may need to charge the battery several times before it is recharged to its full capacity.

If you aren't sure of your dialing system

Make a trial call with the DIAL MODE switch set to T. If the call connects, leave the switch as is; otherwise, set to P.

Prepare the battery pack

Insert the battery into the handset and charge first before you start using your phone.

- 1 Slide open the battery compartment lid of the handset.
- 2 Connect the battery connector with correct polarity (black wire goes on right side and red wire goes on left).
- 3 Insert the battery pack, and close the lid.
- 4 Place the handset on the base unit.

The CHARGE lamp lights up when the handset is properly seated on the charge terminals of the base unit. Charge the battery pack for more than **12 hours** so that the battery is fully charged. The CHARGE lamp remains lit even after charging is completed.

To obtain the best performance from battery

Do not place the handset on the base unit after each call. The battery works best if the handset is returned to the base unit after two or three calls. However, do not leave the handset off the base unit for a long period of time as this will completely discharge the battery pack.

When to purchase a new battery pack

If the battery lasts only a few minutes even after **12 hours** of charging, the usable life of the battery has expired and needs replacement. Contact your local Sony authorized dealer or service center, and ask for Sony **BP-T16** rechargeable battery pack.

Note

Battery life may vary depending on usage condition and ambient temperature.

Making and receiving calls

Making calls

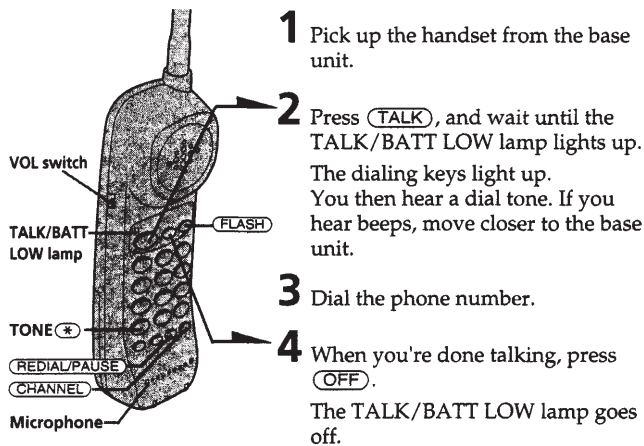

Additional tasks

To	Do this
Adjust the handset volume	Set the VOL switch to H (high), M (middle) or L (low).
Switch to tone dialing temporarily	Press TONE (*) after you're connected. The line will remain in tone dialing until disconnected.

If interference occurs on the handset

When you press **TALK**, the handset automatically searches for the channel with the best reception. However, if you notice interference during a conversation, move closer to the base unit.

If interference persists, press **CHANNEL** to switch to another channel to improve the sound quality of your telephone conversation.

Note

If you hear five short beeps when you press **CHANNEL**, move closer to the base unit.

If the handset battery becomes weak during a call

The handset will beep every three seconds with the TALK/BATT LOW lamp flashing at the same time. Finish your call and charge the battery pack.

Caution

If this occurs, you cannot use the handset without charging it for more than one minutes.

Redialing

- 1 Press **TALK**, and wait until the TALK/BATT LOW lamp lights up.
- 2 Press **REDIAL/PAUSE** to redial the number last dialed.

Note

If the number exceeds 32 digits, the beeps will alert you that the number cannot be dialed.

To erase the last phone number dialed

Press **REDIAL/PAUSE** twice.

The number will be erased from the memory, and you'll hear a long confirmation beep.

Receiving calls

- 1 When you hear the phone ring;
 - Press **TALK** (or any key except **OFF**).
 - or
 - Pick up the handset from the base unit when the handset is placed on the base unit. The TALK/BATT LOW lamp lights up.
- 2 When you're done talking, replace the handset on the base unit or press **OFF**. The TALK/BATT LOW lamp goes off.

Additional tasks

To	Do this
Switch to another call ("call waiting" service*)	Press FLASH . Press the button again to get back to the first caller.

* You need to subscribe to this service from your telephone company.

Notes

- Do not cover the microphone during the conversation; otherwise, the other party cannot hear your voice.
- If you hear beeps during the conversation, move closer to the base unit; otherwise, the call will be disconnected after 15 seconds. Note that, however, you may not hear beeps if it's noisy on the handset.

Speed dialing

You can dial with a touch of a few keys by storing a phone number on a dialing key.

Storing phone numbers

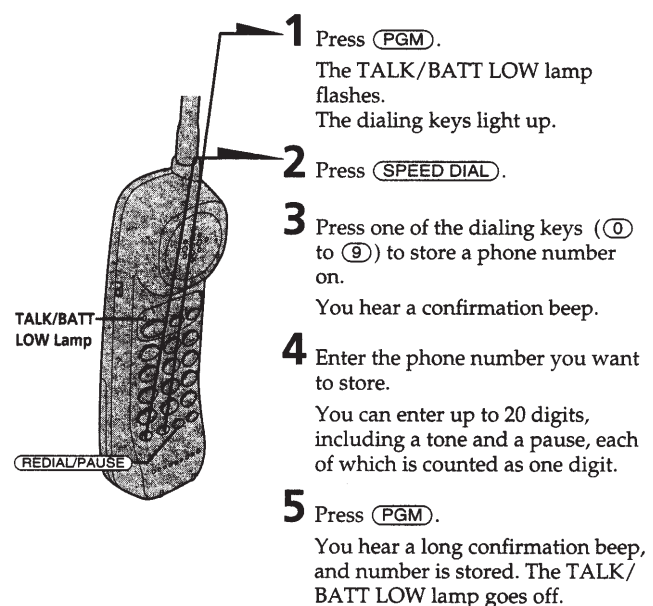

Note

Do not allow more than 20 seconds to elapse between each step of the procedure.

Tips

- If you enter a wrong number, press **(PGM)**, then start from the beginning.
- You can attach the supplied directory on the handset.
- You cannot receive calls while you're storing numbers.



To store a number to be dialed via Private Branch Exchange (PBX)

Before entering a phone number in step 4, do as follows:

- 1 Enter the outside line access digit (e.g., 9).
- 2 Press **(REDIAL/PAUSE)**.

To change a stored number

Store a new number, as described previously.

Making calls with speed dialing

- 1 Press **(TALK)** and wait until the TALK/BATT LOW lamp lights up.
- 2 Press **(SPEED DIAL)**.
- 3 Enter the desired speed dialing number (**(0)** to **(9)**).
The phone number stored in the speed dialing number will be dialed.

Note

If the battery pack in the handset is completely discharged, or is removed from the handset for more than several seconds, the digital security code stored will be lost. If this happens, charge the battery pack and a new security code will be automatically assigned.

Tip

This procedure will change the code in both the base unit and the handset. The code can be changed as often as desired.

Resetting the digital security code

The first time you charge the battery pack, a random security code is automatically assigned between the base unit and the handset. Only a handset which has this security code can make calls through the base unit. This system prevents the possibility of other cordless telephone handsets making calls through your base unit. You normally do not need to reset the security code. However, in the unlikely event that you suspect that another cordless phone uses the same security code, you can manually change the code. Pick up the handset from the base unit, and proceed as follows:

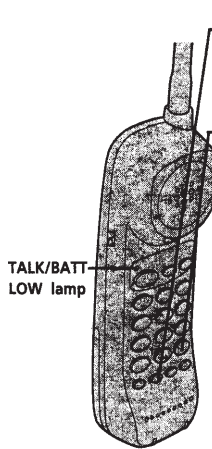
- 
- 1 Press **(PGM)**.
The TALK/BATT LOW lamp flashes.
 - 2 Press **(#)**.
You hear a confirmation beep.
 - 3 Press three of the dialing keys (001 to 999) to store a new code.
 - 4 Press **(PGM)**.
You hear a long confirmation beep and the TALK/BATT LOW lamp goes off.
 - 5 Immediately replace the handset on the base unit.
You hear a long confirmation beep and the phone stores the new code.

Paging

You can page the handset from the base unit. Note that you cannot page if the handset is in use.

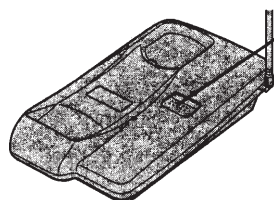

- Press **(HANDSET LOCATOR)**.
The handset rings for about one minute.
To end the page, press **(OFF)** on the handset.

SECTION 2 DISASSEMBLY

Note : Follow the disassembly procedure in the numerical order given.

2-1. CABINET (LOWER) (BASE UNIT)

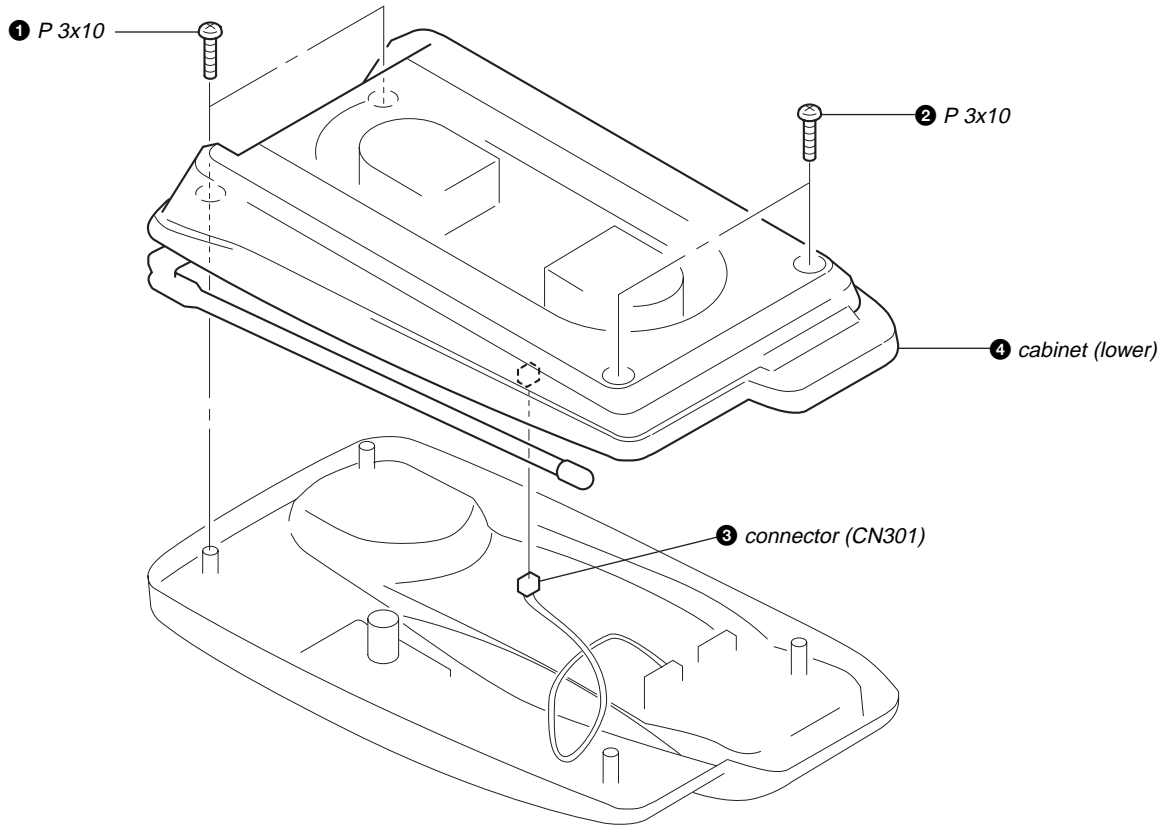

2-2. CABINET (REAR) (HANDSET)

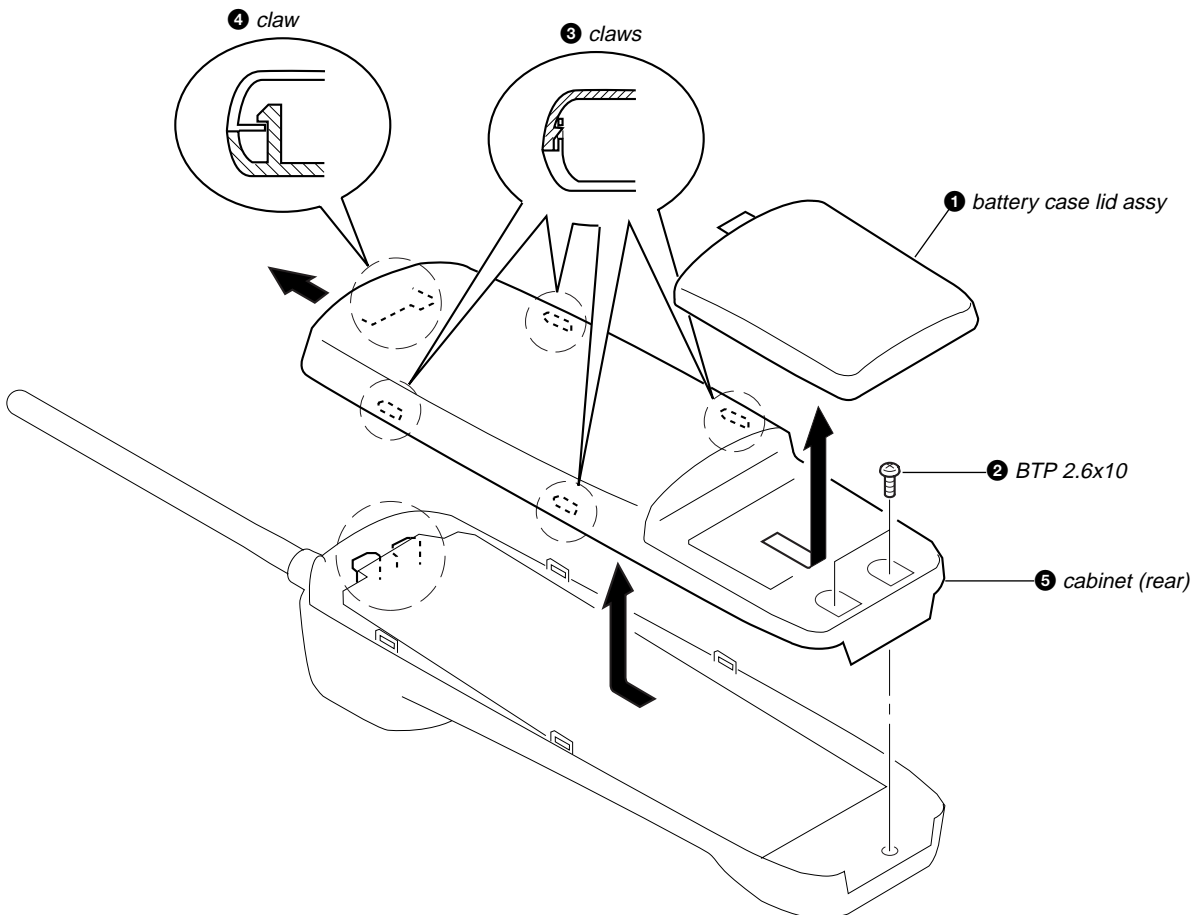

SECTION 3 TEST MODE

BASE UNIT SECTION

MANUAL TEST MODE

Set the Test Mode:

1. Set the **DIAL MODE** switch to "P" (pulse).
2. While pressing the **HANDSET LOCATOR** key, insert the AC adaptor (Reset start).
3. With the **HANDSET LOCATOR** key, still held down, switch the **DIAL MODE** switch "P" (pulse) → "T" (tone) → "P" (pulse).
4. When the **HANDSET LOCATOR** key is released, test mode starts.
5. Firstly, "0" will be dialled out at 10 pps. Then "1", "4", "8" and "#" will be sent out by DTMF.
6. Set to TX ON. Goes to external line state in 1 CH.

Release the Test Mode:

1. Pull out the AC adaptor or turn off the power.

MACHINE TEST MODE

Set the Test Mode:

1. With one of the CH setting terminals in "H" input state, cause Reset of Power ON. Equipment enters machine test mode.
2. Setting of CH according to logic input with CH setting terminal.
3. ON/OFF of TX is according to the input logic of the DIAL MODE terminal.

Release the Test Mode:

1. Pull out the AC adaptor or turn off the power.
2. Remove the short plug and turn on the power again.

– base main board (conductor side) –

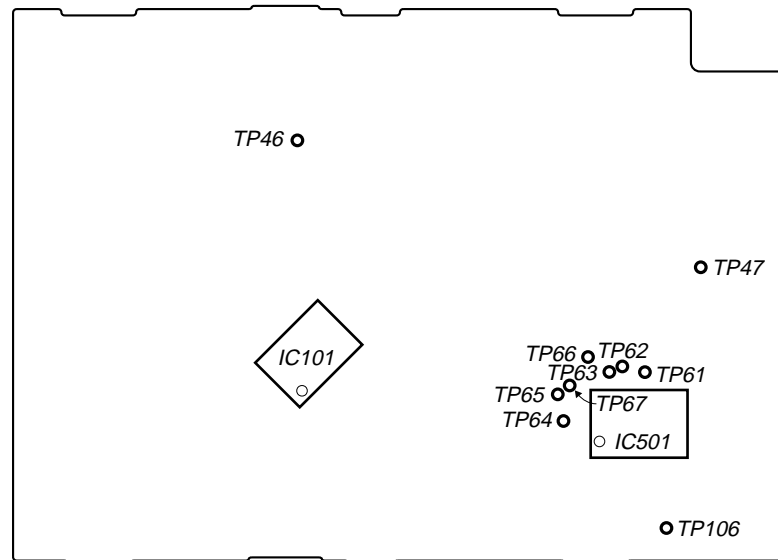

Channel Setting:

During startup in machine test mode, make the following channel settings by loading the terminal input data.

Pin No. Channel	23 M1 (TP61)	24 M2 (TP62)	25 M3 (TP63)	26 M4 (TP64)	TX frequency (MHz)	RX frequency (MHz)
CH1	H	L	L	L	43.720	48.760
CH2	L	H	L	L	43.740	48.840
CH3	H	H	L	L	43.820	48.860
CH4	L	L	H	L	43.840	48.920
CH5					43.920	49.020
CH6					43.960	49.080
CH7					44.120	49.100
CH8					44.160	49.160
CH9					44.180	49.200
CH10					44.200	49.240
CH11					44.320	49.280
CH12					44.360	49.360
CH13					44.400	49.400
CH14	H	L	H	L	44.460	49.460
CH15	L	H	H	L	44.480	49.500
CH16	H	H	H	L	46.610	49.670
CH17	L	L	L	H	46.630	49.845
CH18					46.670	49.860
CH19					46.710	49.770
CH20					46.730	49.875
CH21					46.770	49.830
CH22					46.830	49.890
CH23	H	L	L	H	46.870	49.930
CH24	L	H	L	H	46.930	49.990
CH25	H	H	L	H	46.970	49.970
TEST1	L	L	H	H	43.780	48.800
TEST2	H	L	H	H	43.890	48.970
TEST3	L	H	H	H	46.800	49.910
TEST4	H	H	H	H	46.900	49.950

Machine Test Mode Input / Output:

1. Input (Input ports for other than main tasks)

Pin Name	Pin No.	Function	Logic
M1 (TP61)	23	Setting the CH (channel)	Refer to channel setting
M2 (TP62)	24		
M3 (TP63)	25		
M4 (TP64)	26		
DIAL MODE (TP47)	17	Setting the TX ON/OFF	TONE : open, PULSE : short
HANDSET LOCATOR (TP46)	16	Manual : Channel increment	Incrementing of channels in order from 1 to 25.
		Machine : Dial data "5" is output to DTMF/DP exchange	Key input with "L" input. The first time there is output of "5" with DTMF.

29 TEST1 (TP67)	28 TEST2 (TP66)	27 TEST3 (TP65)	Operation with CHARGE LED	Operation with TX ON
L	L	L	If RSSI (H) is detected : Light ON	If RSSI (H) is detected : Light ON
L	L	H	If RSSI (L) is detected : Light ON	If RSSI (L) is detected : Light ON
L	H	L	If TX LOCK is detected : Light OFF	If TX LOCK is detected : Light OFF
L	H	H	If RX LOCK is detected : Light OFF	If RX LOCK is detected : Light OFF
H	L	L		BEEP output
H	L	H		ID CODE output
H	H	L	If RING is detected : Light ON	If RING is detected : Light ON
H	H	H	If HANDSET LOCATOR key is input : Light ON	If HANDSET LOCATOR key is input : Light ON

2. Output (Output ports for other than main tasks)

Pin Name	Pin No.	Function	H Logic	L Logic
CHARGE DET (TP21)	18	State in section 1. Input	Refer to section 1. Input	

HANDSET SECTION

MANUAL TEST MODE

Set the Test Mode:

1. Enter the test mode by pressing **[0]** key while pressing **[1]** and **[TALK]** keys when in idle condition.
(Key operation **[0]** → **[1]** → **[TALK]**)
2. The RINGER will ring for 500 msec. when the test mode is started.
3. Measurement mode of consumption current. (42# state)
4. Use key input to carry out the various settings.
5. Use port inputs to set output from LED terminals.

Release the Test Mode:

1. Press the **[0]**, **[0]** and **[#]** keys.
2. Turn off the power. (Remove the battery and replace them.)

MACHINE TEST MODE

Set the Test Mode:

1. When power on reset is applied while a "H" (high) is input the TEST SW (TP43) terminal (IC501 ④0 pin), the RING (Level H, 500 msec) sounds.
2. Following that, at timing in which the TEST SW terminal has "H" (high) input, there is output of "L" (low) by the CH (channel) setting control terminal. Then there is PLL setting to the CH which was read to with the CH setting terminal according to that "L" (low) output.
3. Set the TX setting to TX OFF.
4. The channel is set by voice not by data.
5. Use port inputs to set output from LED terminals.

Release the Test Mode:

1. Press the **[OFF]** key.
2. Remove the short plug and turn on the power.

– hand main board (side B) –

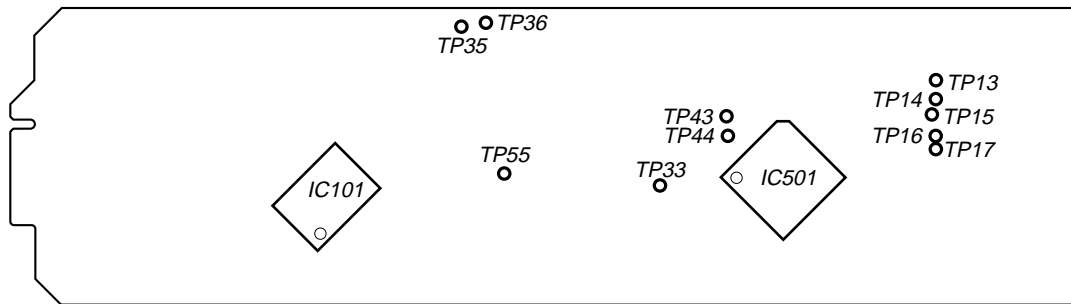

Channel Setting:

During startup in machine test mode, make the following channel settings by loading the terminal input data.

Pin No. Channel	34 ROW5 (TP13)	33 ROW4 (TP14)	32 ROW3 (TP15)	31 ROW2 (TP16)	29 ROW1 (TP17)	TX frequency (MHz)	RX frequency (MHz)
CH1	H	L	L	L	L	48.760	43.720
CH2	H	L	L	L	H	48.840	43.740
CH3	H	L	L	H	L	48.860	43.820
CH4	H	L	L	H	H	48.920	43.840
CH5	H	L	H	L	L	49.020	43.920
CH6	H	L	H	L	H	49.080	43.960
CH7	H	L	H	H	L	49.100	44.120
CH8	H	L	H	H	H	49.160	44.160
CH9	H	H	L	L	L	49.200	44.180
CH10	H	H	L	L	H	49.240	44.200
CH11	H	H	L	H	L	49.280	44.320
CH12	H	H	L	H	H	49.360	44.360
CH13	H	H	H	L	L	49.400	44.400
CH14	H	H	H	L	H	49.460	44.460
CH15	H	H	H	H	L	49.500	44.480
CH16	L	L	H	H	L	49.670	46.610
CH17	L	L	H	H	H	49.845	46.630
CH18	L	H	L	L	L	49.860	46.670
CH19	L	H	L	L	H	49.770	46.710
CH20	L	H	L	H	L	49.875	46.730
CH21	L	H	L	H	H	49.830	46.770
CH22	L	H	H	L	L	49.890	46.830
CH23	L	H	H	L	H	49.930	46.870
CH24	L	H	H	H	L	49.990	46.930
CH25	L	H	H	H	H	49.970	46.970
TEST1	L	L	L	H	L	48.800	43.780
TEST2	L	L	L	H	H	48.970	43.890
TEST3	L	L	H	L	L	49.910	46.800
TEST4	L	L	H	L	H	49.950	46.900

Machine Test Mode Input / Output:

1. Input (Input ports for other than main tasks)

Pin Name	Pin No.	Function	Logic
ROW1 (TP17)	29	Setting the CH (channel)	Refer to channel setting
ROW2 (TP16)	31		
ROW3 (TP15)	32		
ROW4 (TP14)	33		
ROW5 (TP13)	34		
TEST CH (TP33)	1	Control terminal for setting the CH (channel)	H : OFF, L : ON
TEST SW (TP43)	40	Start up of the test mode	H : Start, L : Not start
TEST ACK (TP44)	44	During the test mode, causes start of intermittent operation with external input.	H : Intermittent start

2. Output (Output ports for other than main tasks)

Pin Name	Pin No.	Function	H Logic	L Logic
TALK LED (TP35)	48	Various input/output monitor output (default : RSSI (H) detection).	No detection	Detection
KEY LED (TP55)	2	During test mode : All light lit. However, does not include measurement of consumption current.	No light	Light

Key Processing (Setting the Manual Test Mode) :

1. (Upper position) (Lower position) Set with #.

2. 3X# can be substituted with X*.

Upper position Lower position	0	1	2	3	4					7
					TX	RX RF	RX AF	MIC	Lk	
0	QUIT	10 ch	20 ch	Batt Alarm	H	A	L	T	×	KEY TEST
1	1 ch	11 ch	21 ch	CHARGE DET	×	○	×	×	×	
2	2 ch	12 ch	22 ch		×	○	○	×	×	
3	3 ch	13 ch	23 ch		○	○	×	×	×	
4	4 ch	14 ch	24 ch	RX LOCK	○	○	○	×	×	
5	5 ch	15 ch	25 ch	TX LOCK	○	○	○	○	×	
6	6 ch	16 ch	T1 ch	RSSI (H)	○	○	○	○	○	
7	7 ch	17 ch	T2 ch	RSSI (L)	—	—	—	—	—	
8	8 ch	18 ch	T3 ch	DATA TX	—	—	—	—	—	
9	9 ch	19 ch	T4 ch		—	—	—	—	—	
Purpose	CH setting only			SIGOUT control						General operation
Application	The standard is external communication state. State for standard electrical adjustment process.			Condition surveillance with TALK LED.	Measurement mode of consumption current.					

○ : ON, × : OFF

- By pressing the CH key there is increment of the channel. However, this does not include the test channel.
- Control of the power source during 38# DATA TX is (TX & RX RF & RX AF=ON) in 44# state.
- Control of the power source during the 70# key check mode is 41# state (TX OFF).
- For CH setting, SIGOUT control and power source control (with the exception of above-mentioned 38# state) the state can be set independently.

Example : In 15 ch, the order for carrying out TX modulation level and RSSI (H) sensitivity setting is as follows :

The following are possible : 15# → 44# → 36#
 36# → 15# → 44#
 44# → 36# → 15#

SECTION 4 ELECTRICAL ADJUSTMENTS

BASE UNIT SECTION

Note:

- Apply 9V dc from regulated DC power supply.
- Perform the adjustment at TEST3CH (28CH : 49.910 MHz) as a rule.
- Set to base unit manual test mode. (Refer to page 7)
- Switch position :
S302 (DIAL MODE) : P (pulse)

TX SECTION ADJUSTMENT

- The electrolytic capacitor (10 μ F/10 V) connected TP23 (DET OUT) to TP19 (GND). (Only TX section adjustment)

TX VT Adjustment

Setting :

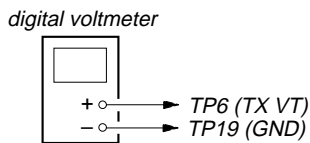

Procedure :

1. The digital voltmeter connected TP6 (TX VT) to TP19 (GND).
2. Adjust the L52 for 2.2 ± 0.05 V reading on the digital voltmeter.

RX VT Adjustment

Setting :

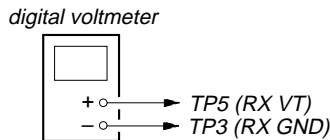

Procedure :

1. The digital voltmeter connected TP5 (RX VT) to TP3 (RX GND).
2. Adjust the L101 for 2.4 ± 0.05 V reading on the digital voltmeter.

RX SECTION ADJUSTMENT

RX LEVEL Adjustment

Note:

- Perform the adjustment at TEST3CH (28CH : 49.910 MHz) as a rule.

Setting :

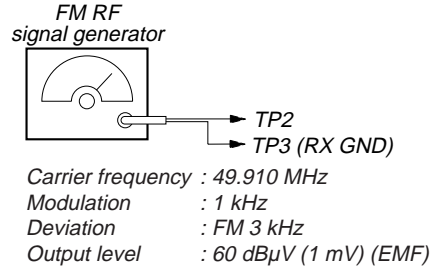

Procedure :

1. Adjust the FL101 for the maximum reading on the level meter. Also check that the output level is the specified values.

Specified Value : -1.4 to -9.6 dBV

RSSI Hi Adjustment

Note:

- Perform the adjustment at TEST3CH (28CH : 49.910 MHz) as a rule.

Setting :

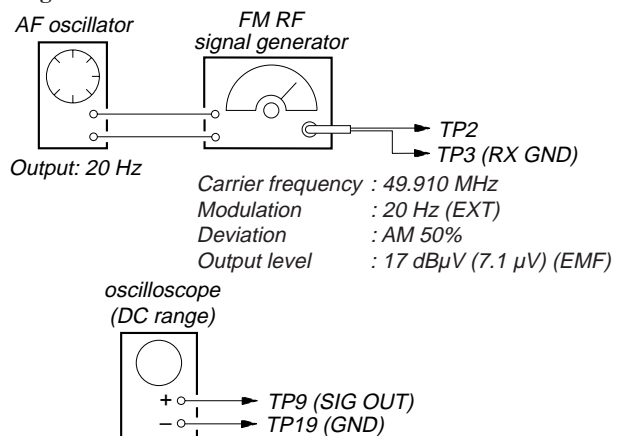

Procedure :

1. Use the oscilloscope to confirm the FM RF signal generator input (AF) signal waveform and RSSI signal, and use the RV101 so that they are synchronized (duty is synchronized).

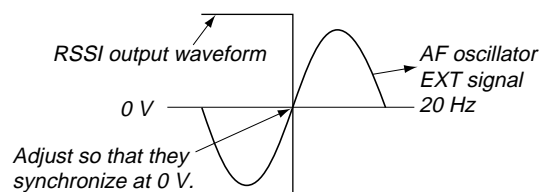

RSSI WAVEFORM

Adjustment Location : base main board (See page 13)

Adjustment Location :

– base main board (component side) –

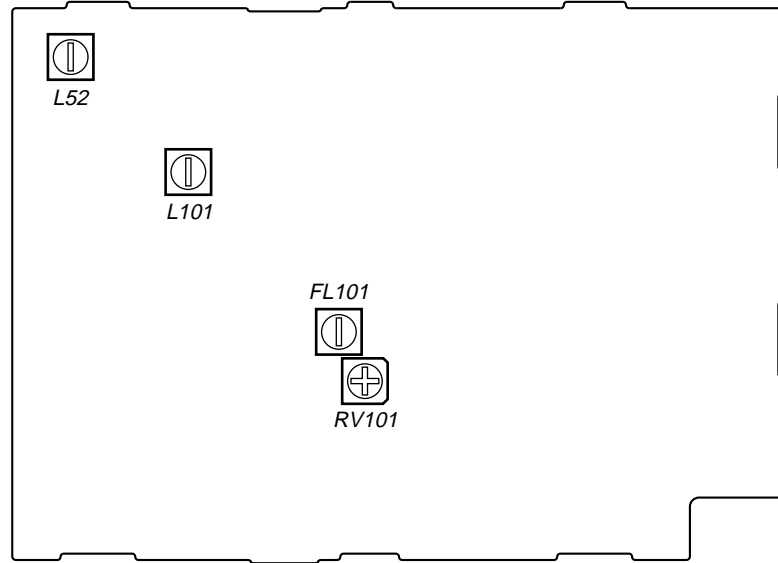

– base main board (conductor side) –

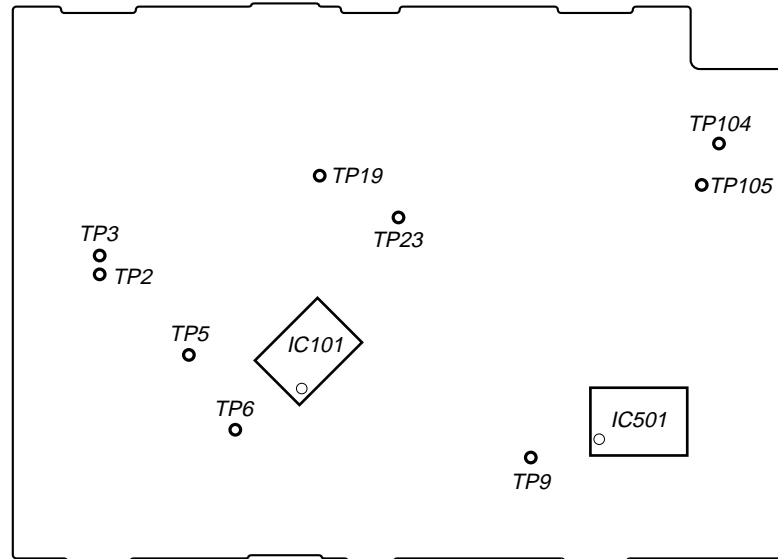

HANDSET SECTION

Note:

- Apply 3.6 V dc from regulated DC power supply.
- Perform the adjustment at TEST1CH (26CH : 43.780 MHz) as a rule.
- Set to handset manual test mode. (Refer to page 9)

TX SECTION ADJUSTMENT

TX VT Adjustment

Setting :

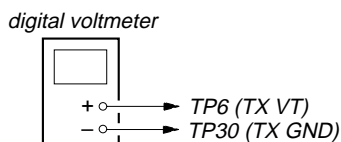

Procedure :

1. The digital voltmeter connected TP6 (TX VT) to TP30 (TX GND).
2. Adjust the L52 for 0.9 ± 0.05 V reading on the digital voltmeter.

RX VT Adjustment

Setting :

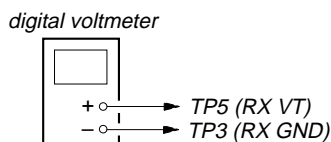

Procedure :

1. The digital voltmeter connected TP5 (RX VT) to TP3 (RX GND).
2. Adjust the L102 for 3.0 ± 0.05 V reading on the digital voltmeter.

RX SECTION ADJUSTMENT

RX LEVEL Adjustment

Note:

- Perform the adjustment at TEST1CH (26CH : 43.780 MHz) as a rule.

Setting :

VOL switch : M

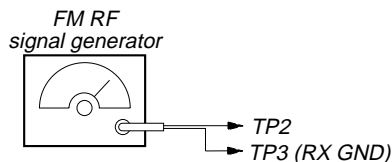

Carrier frequency : 43.780 MHz
 Modulation : 1 kHz
 Deviation : FM 3 kHz
 Output level : 60 dB μ V (1 mV) (EMF)

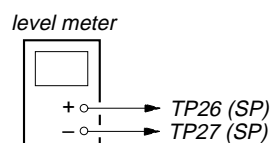

Procedure :

1. Adjust the FL101 for the maximum reading on the level meter. Also check that the output level is the specified values.

Specified Value : -9.5 to -15.5 dBV

RSSI Hi Adjustment

Note:

- Perform the adjustment at TEST1CH (26CH : 43.780 MHz) as a rule.

Setting :

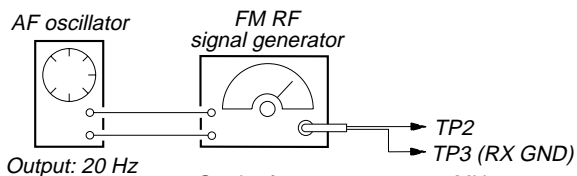

Output: 20 Hz

Carrier frequency : 43.780 MHz
 Modulation : 20 Hz (EXT)
 Deviation : AM 50%
 Output level : 5.5 dB μ V (1.88 μ V) (EMF)

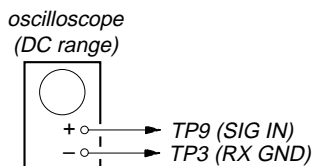

Procedure :

1. Use the oscilloscope to confirm the FM RF signal generator input (AF) signal waveform and RSSI signal, and use the RV101 so that they are synchronized (duty is synchronized).

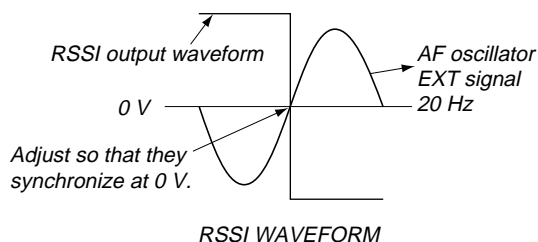

Adjustment Location : hand main board (See page 15)

Adjustment Location :

– hand main board (side A) –

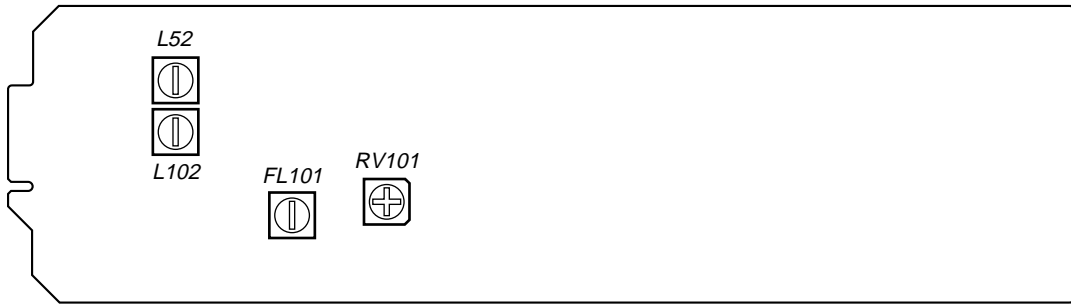

– hand main board (side B) –



SECTION 5 DIAGRAMS

5-1. IC PIN DESCRIPTIONS

• IC501 SB662104A-4L43-TLM (SYSTEM CONTROL) (BASE UNIT)

Pin No.	Pin Name	I/O	Pin Description
1	STB	O	Strobe signal output to PLL.
2	DATA	O	Serial data output to PLL.
3	CLK	O	Serial clock output to PLL.
4	RX-DATA	I	RX data input
5	SIG-IN	I	RSSI/PLL-LOCK signal input (L: RSSI, H: PLL-LOCK)
6	$\overline{\text{H-MUTE}}$	O	Half mute control output (L: Mute ON)
7	TX-DATA	O	TX data, external system alarm output
8	VSS	—	Ground
9	OSC2	O	Crystal oscillation output (4.048 MHz)
10	OSC1	I	Crystal oscillation input (4.048 MHz)
11	VDD	—	Power supply pin (+3 V)
12	$\overline{\text{RESET}}$	I	System reset input (L: Reset)
13	TEST	I	Test pin (Connect to ground in this set.)
14	POW-DET	I	Power failure detection input (L: Power failure)
15	MBR	I	Make 30/40 (%) select input (H: 30%, L: 40%)
16	PAGE	I	HANDSET LOCATOR input (H: input)
17	DIAL MODE	I	DIAL MODE select input
18	$\overline{\text{CHG-DET}}$	I	Charge detection input (L: Charge)
19	RSSI H/L	O	RSSI sensitivity select output (L: Low sensitivity)
20	DP	O	Dial pulse ON/OFF control output
21	DTMF	O	DTMF generator output
22	$\overline{\text{TX +B CTRL}}$	I	TX B+ ON/OFF control input (L: TX ON)
23 – 26	M1 – 4	I	Channel setting for test mode 1 – 4.
27 – 29	TEST3 – 1	I	Test mode setting 3 – 1
30	RING	I	Ring detection input (L: Ring input)

• IC501 SH66356C-4L44 (SYSTEM CONTROL) (HANDSET)

Pin No.	Pin Name	I/O	Pin Description
1	$\overline{\text{TEST CH}}$	O	Test mode channel control output (L: Active)
2	$\overline{\text{KEY LED}}$	O	Key LED ON/OFF control output (L: ON) (Fixed at "H" in this set.)
3	SIG-IN	I	RSSI/PLL-LOCK signal input (L: RSSI, H: PLL-LOCK)
4	PLL-STB	O	Strobe signal output to PLL.
5	PLL-DATA	O	Serial data output to PLL.
6	NC	—	Not used. (Open)
7	PLL-CLK	O	Serial clock output to PLL.
8	RX-DATA	I	RX data input
9, 10	TX-DATA	O	TX data output
11	BEEP	O	Beep signal output
12	$\overline{\text{HOLD}}$	I	Hold control input (L: Hold)
13	$\overline{\text{TX +B CTRL}}$	O	TX B+ ON/OFF control output (L: TX ON)
14	$\overline{\text{RX +B CTRL}}$	O	RX B+ ON/OFF control output (L: RX ON)
15	TEST	I	Test pin (Connect to ground in this set.)
16	VSS	—	Ground
17	OSC1	I	Crystal oscillation input (4.048 MHz)
18, 19	NC	—	Not used. (Open)
20	OSC2	O	Crystal oscillation output (4.048 MHz)
21	$\overline{\text{RESET}}$	I	System reset input (L: Reset)
22, 23	$\overline{\text{ACT3, 4}}$	O	Intermittent reception activation control (L: Active)
24 – 27	COL0 – 3	I	Key input 0 – 3
28	MIC	O	Microphone bias output control
29	ROW1	O	Key scan output 1
30	NC	—	Not used. (Open)
31 – 34	ROW2 – 5	O	Key scan output 2 – 5
35, 36	—	—	Not used. (Open)
37	$\overline{\text{BATT-LOW}}$	I	Battery low level detection input
38	CHG-DET	I	Charge detection input (H: Charge)
39	VDD	—	Power supply pin (+3 V)
40	TEST SW	I	Test mode activation input (H: Start)
41	—	—	Not used. (Connect to ground.)
42, 43	NC	—	Not used. (Open)
44	TEST ACT	I	During test mode, causes start of intermittent operation with external input.
45	RSSI H/L	O	RSSI sensitivity select output (L: Low sensitivity)
46	$\overline{\text{H.MUTE}}$	O	Half mute control output (L: Mute ON)
47	BATT-DET	I	Battery detection input (H: Battery detection)
48	$\overline{\text{LED}}$	O	TALK/BATT LOW LED control output (L: LED ON)

5-2. BLOCK DIAGRAM — BASE UNIT SECTION —

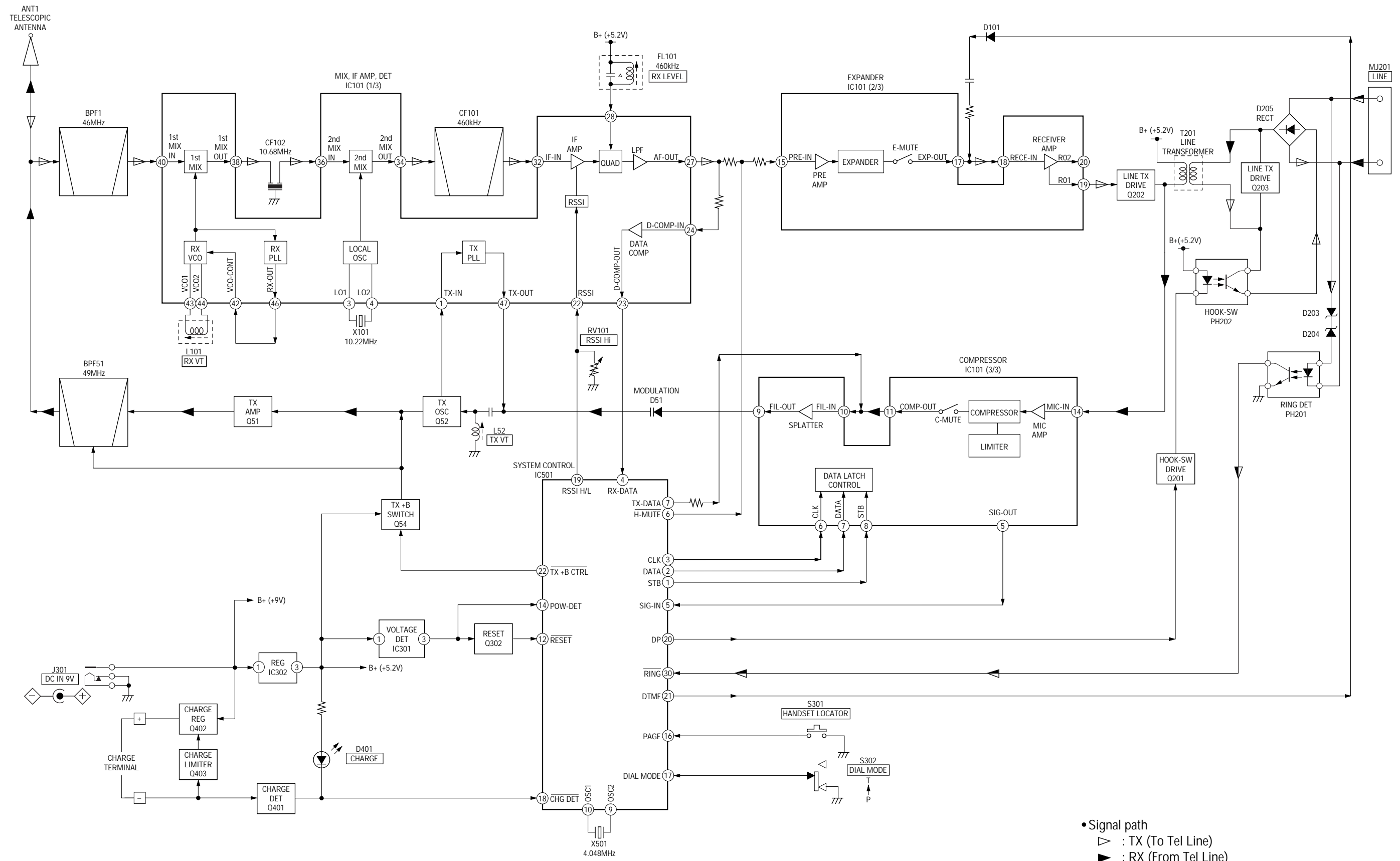

• Signal path
 ▷ : TX (To Tel Line)
 ◼ : RX (From Tel Line)
 ◻ : bell

5-3. BLOCK DIAGRAM — HANDSET SECTION —

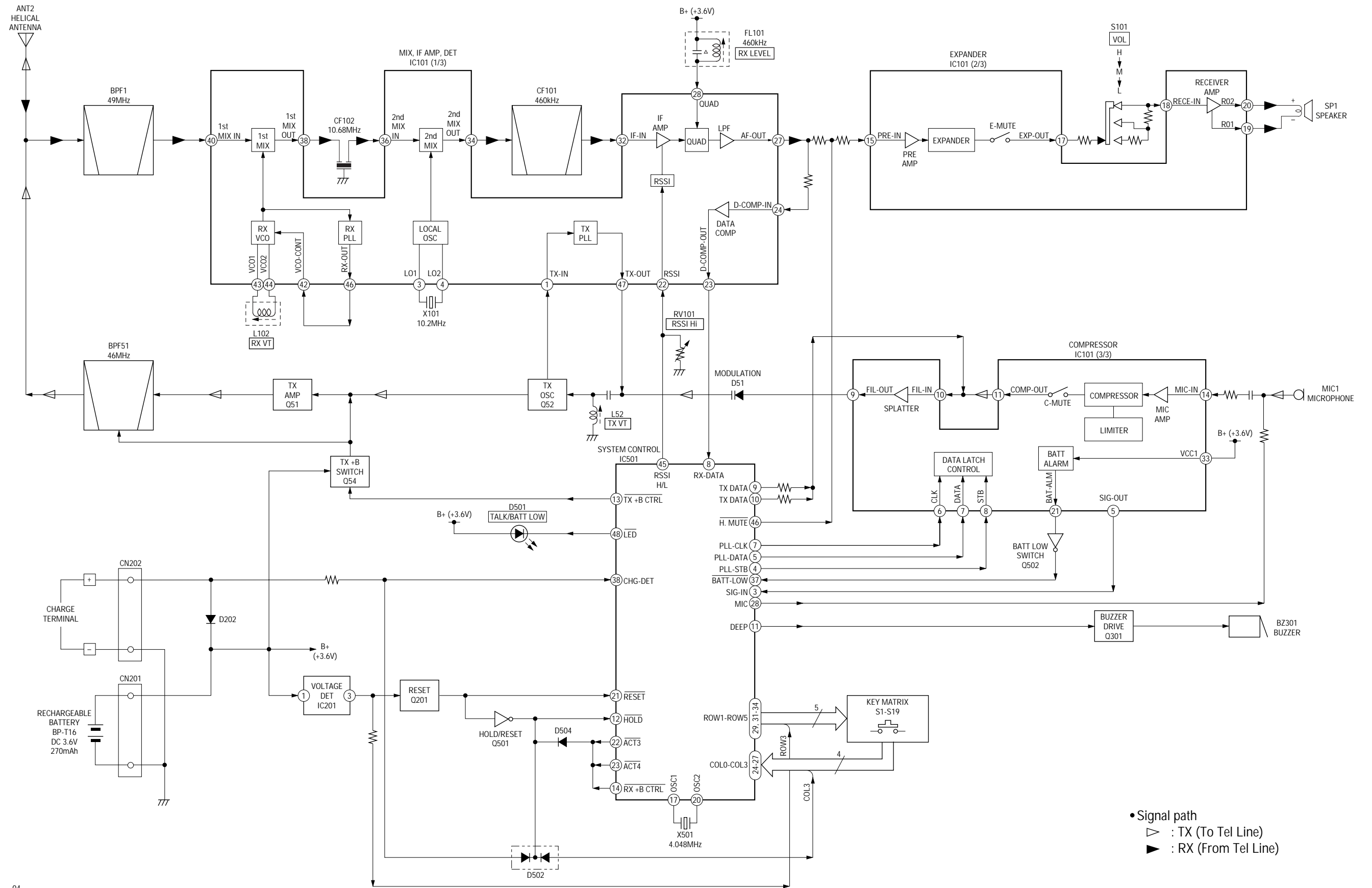

• Signal path
 ▷ : TX (To Tel Line)
 ◀ : RX (From Tel Line)

5-4. PRINTED WIRING BOARD — BASE UNIT SECTION —

【 BASE MAIN BOARD 】

• Semiconductor Location

Ref. No.	Location
D1	C-2
D51	G-2
D101	D-8
D201	B-9
D203	B-8
D204	B-8
D205	A-8
D206	B-2
D207	B-1
D208	G-9
D301	C-7
D401	B-5
D501	F-7
IC101	E-4
IC301	G-10
IC302	D-8
IC501	F-8
PH201	C-8
PH202	B-7
Q51	E-1
Q52	F-2
Q54	E-2
Q201	B-6
Q202	D-6
Q203	A-7
Q302	F-10
Q401	A-2
Q402	B-5
Q403	B-4

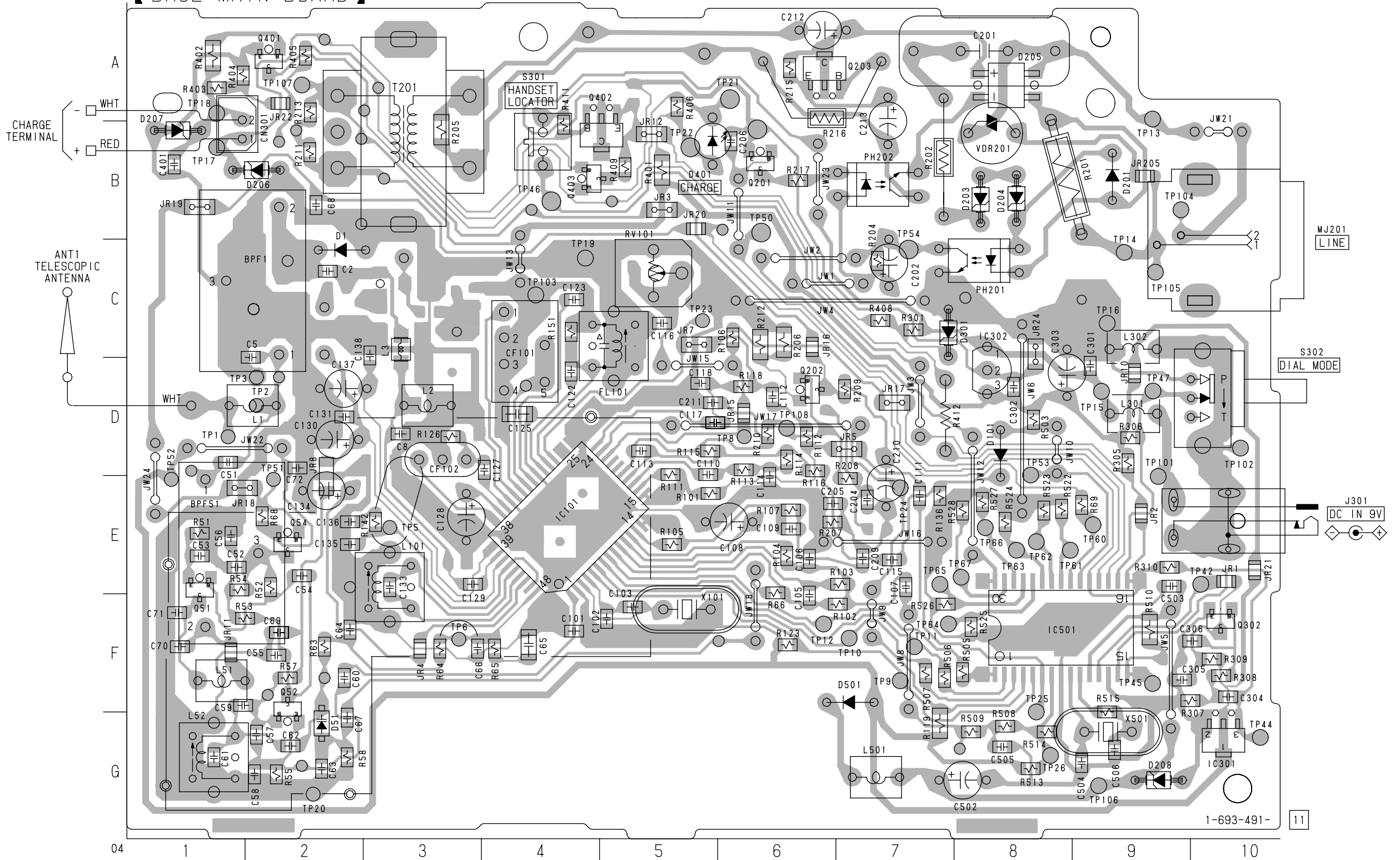

Note on Printed Wiring Boards:

- : parts extracted from the component side.
- △ : internal component.
- ▨ : Pattern from the side which enables seeing.

Note on Schematic Diagram:

- All capacitors are in μF unless otherwise noted. pF : μpF 50 WV or less are not indicated except for electrolytics and tantalums.
- All resistors are in Ω and $1/4\text{W}$ or less unless otherwise specified.
- △ : internal component.
- ▨ : nonflammable resistor.
- ▭ : panel designation.
- ⊕ : B+ Line.

- ▭ : adjustment for repair.
- Power voltage is dc 9 V and fed with regulated dc power supply from external power voltage jack.
- Power voltage is dc 12 V and fed with regulated dc power supply from MJ201 with 100 Ω in series.
- Voltage is dc with respect to ground under no-signal condition.
- no mark : TALK
- * : Impossible to measure

- Voltages are taken with a VOM (Input impedance 10 M Ω). Voltage variations may be noted due to normal production tolerances.
- Signal path.
- ▽ : TX (To Tel Line)
- ▶ : RX (From Tel Line)
- ⬇ : bell

5-5. SCHEMATIC DIAGRAM — BASE UNIT SECTION —

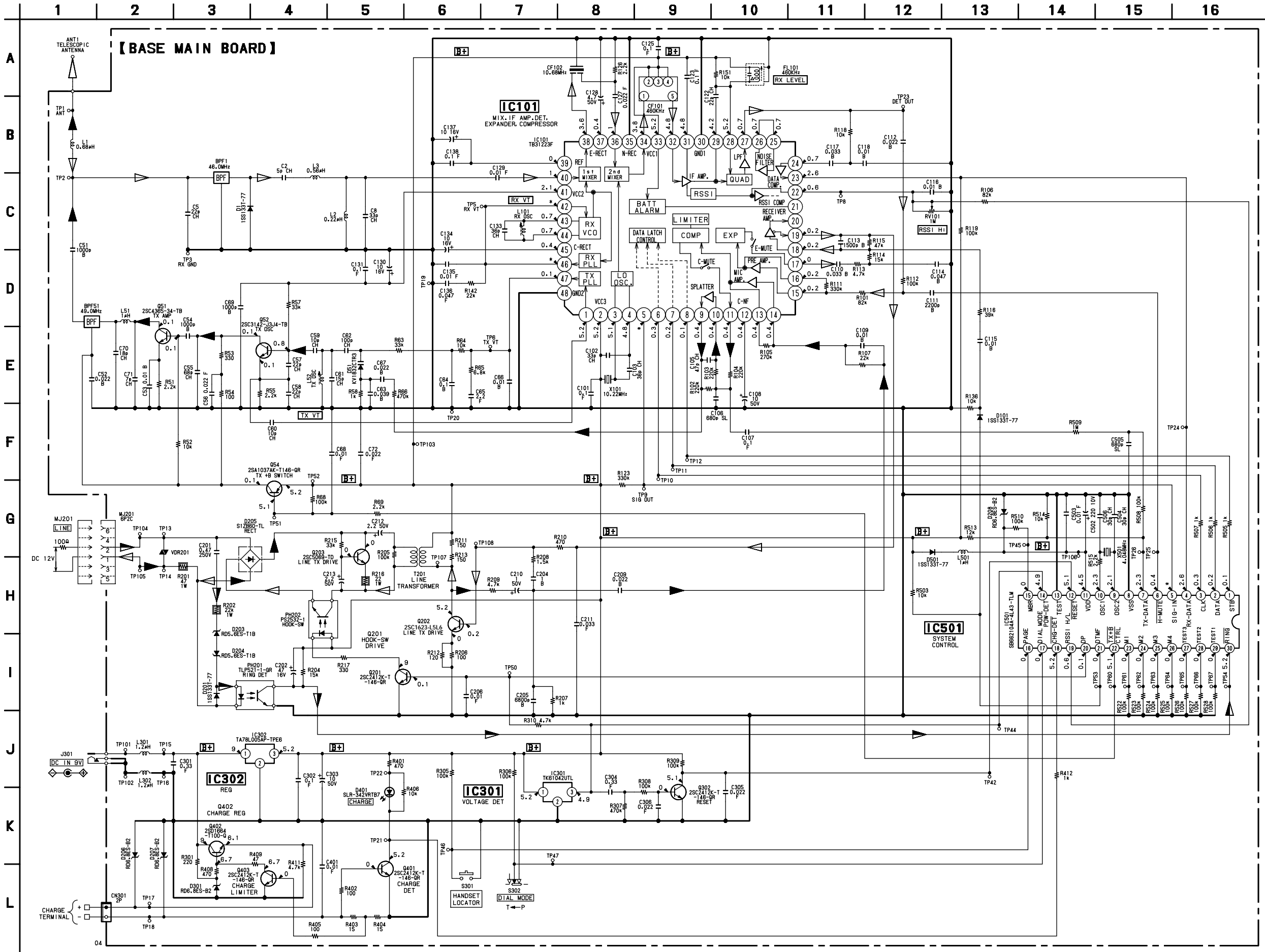

5-6. PRINTED WIRING BOARD — HANDSET SECTION —

【HAND MAIN BOARD】(SIDE A)

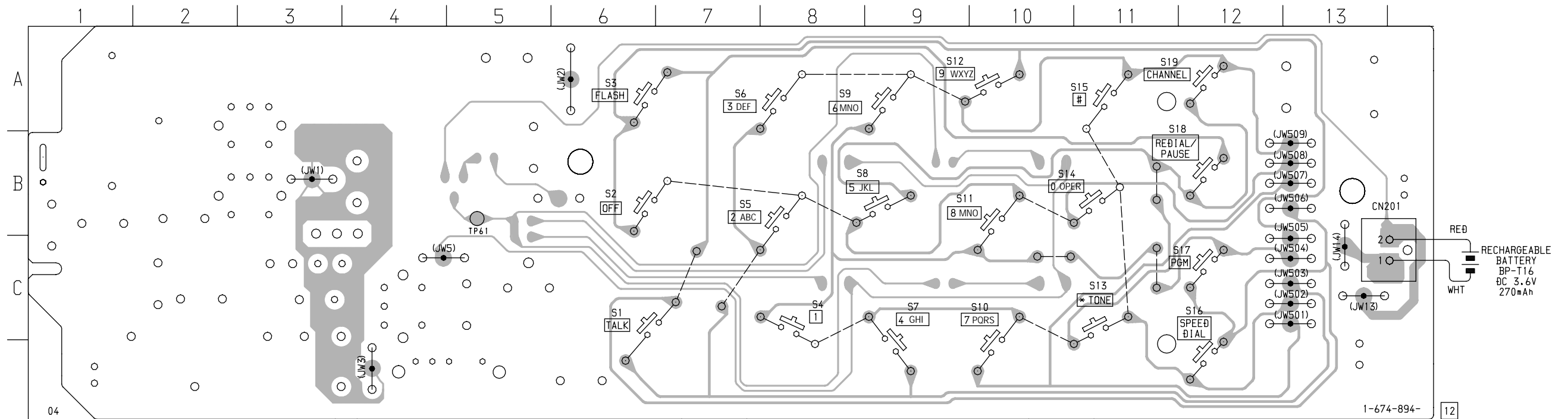

【HAND MAIN BOARD】(SIDE B)

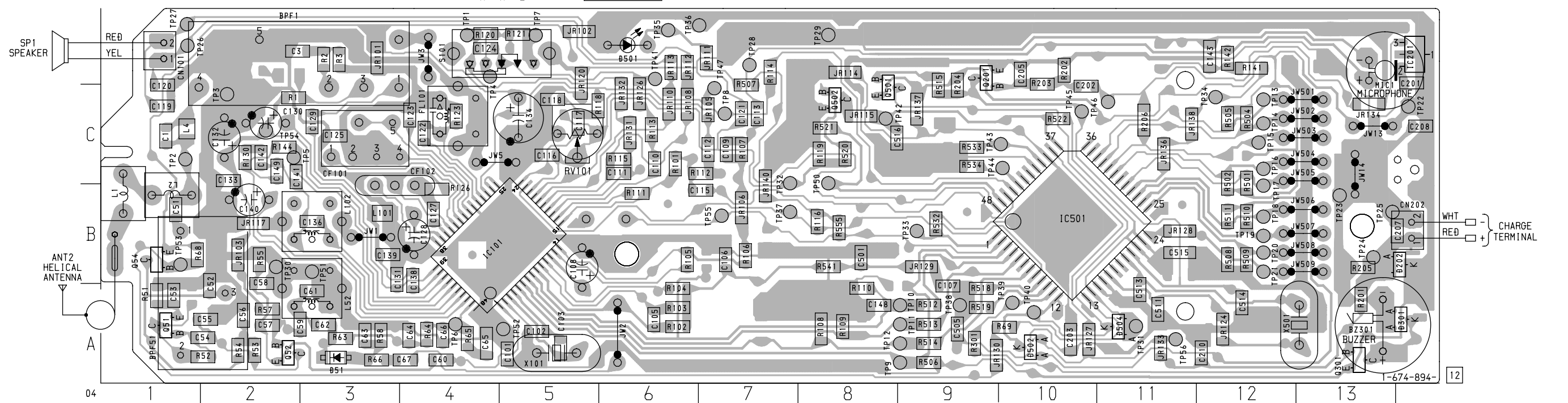

• Semiconductor Location

Ref. No.	Location	Ref. No.	Location
D51	A-3	IC501	B-10
D202	B-14	Q51	A-1
D301	A-14	Q52	A-2
D501	D-6	Q54	B-1
D502	A-10	Q201	D-9
D504	A-11	Q301	A-13
IC101	B-5	Q501	C-8
IC201	D-14	Q502	C-8

Note:

- : parts extracted from the component side.
- - - ○ : Carbon pattern.
- △ : internal component.
- ▨ : Pattern from the side which enables seeing. (The other layer's patterns are not indicated.)

Caution:

Pattern face side: Parts on the pattern face side seen from the (Side B) pattern face are indicated.
 Parts face side: Parts on the parts face side seen from the (Side A) parts face are indicated.

5-7. SCHEMATIC DIAGRAM — HANDSET SECTION — • Refer to page 24 for Note.

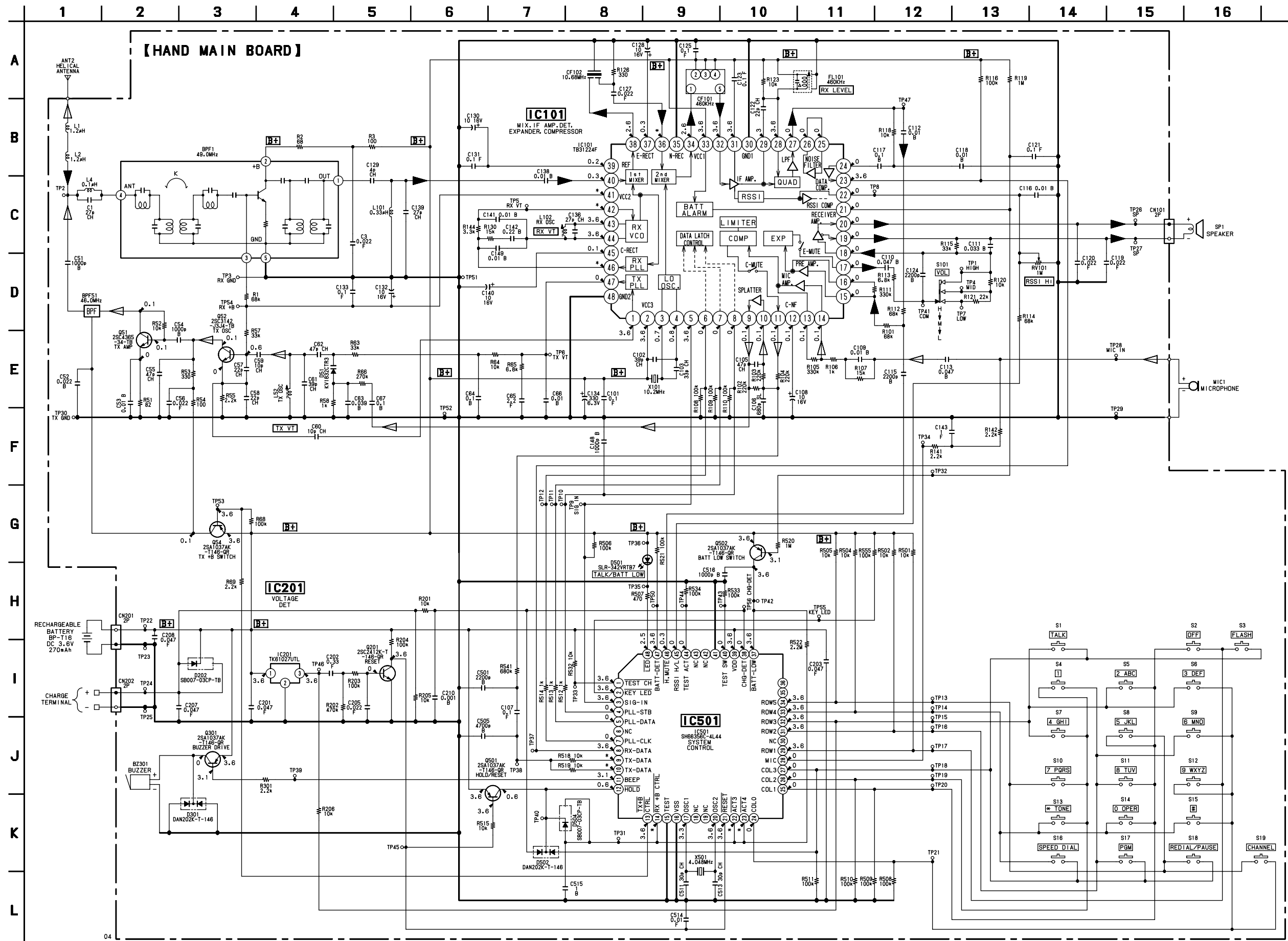

SECTION 6 EXPLODED VIEWS

Note on Schematic Diagram:

- All capacitors are in μF unless otherwise noted. pF: $\mu\mu\text{F}$ 50 WV or less are not indicated except for electrolytics and tantalums.
- All resistors are in Ω and $\frac{1}{4}W$ or less unless otherwise specified.
- Δ : internal component.
- : panel designation.
- B+ : B+ Line.
- : adjustment for repair.
- Power voltage is dc 3.6 V and fed with regulated dc power supply from battery terminal.
- Voltage is dc with respect to ground under no-signal condition.
- no mark : TALK
- * : Impossible to measure
- Voltages are taken with a VOM (Input impedance 10 M Ω). Voltage variations may be noted due to normal production tolerances.
- Signal path.
- ∇ : TX (To Tel Line)
- \blacktriangleright : RX (From Tel Line)

NOTE:

- The mechanical parts with no reference number in the exploded views are not supplied.
- Items marked "*" are not stocked since they are seldom required for routine service. Some delay should be anticipated when ordering these items.

- -XX and -X mean standardized parts, so they may have some difference from the original one.
- Color Indication of Appearance Parts
Example :
KNOB, BALANCE (WHITE) ... (RED)

↑ ↑
Parts Color Cabinet's Color

- Accessories and packing materials and hardware (# mark) list are given in the last of this parts list.

6-1. BASE UNIT SECTION

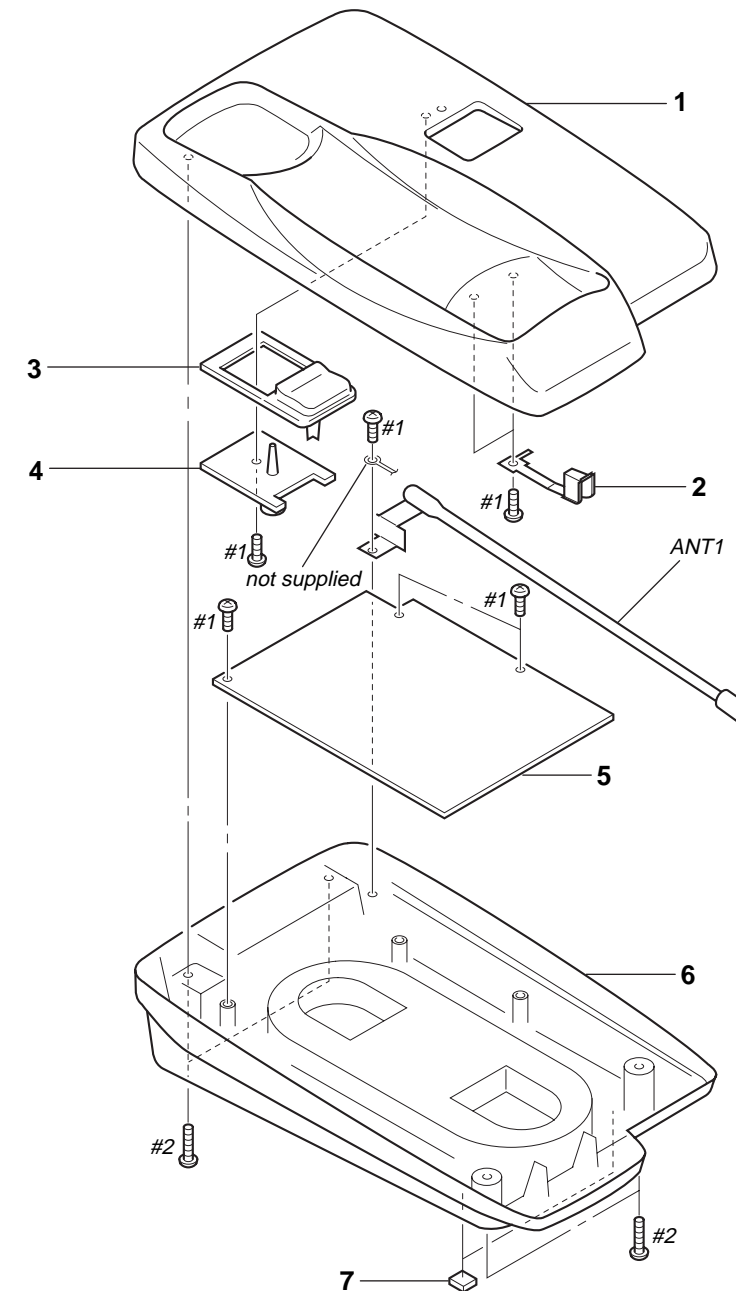

Ref. No.	Part No.	Description	Remark	Ref. No.	Part No.	Description	Remark
1	3-038-929-02	CABINET (UPPER)		* 5	A-3622-375-A	BASE MAIN BOARD, COMPLETE	
2	3-038-932-01	TERMINAL (CHARGE), BASE		6	3-038-924-02	CABINET (LOWER)	
3	3-038-930-01	BUTTON (HANDSET LOCATOR)		7	3-936-696-21	FOOT, RUBBER	
4	3-038-931-01	LENS		ANT1	1-754-075-21	ANTENNA, TELESCOPIC	

6-2. HANDSET SECTION

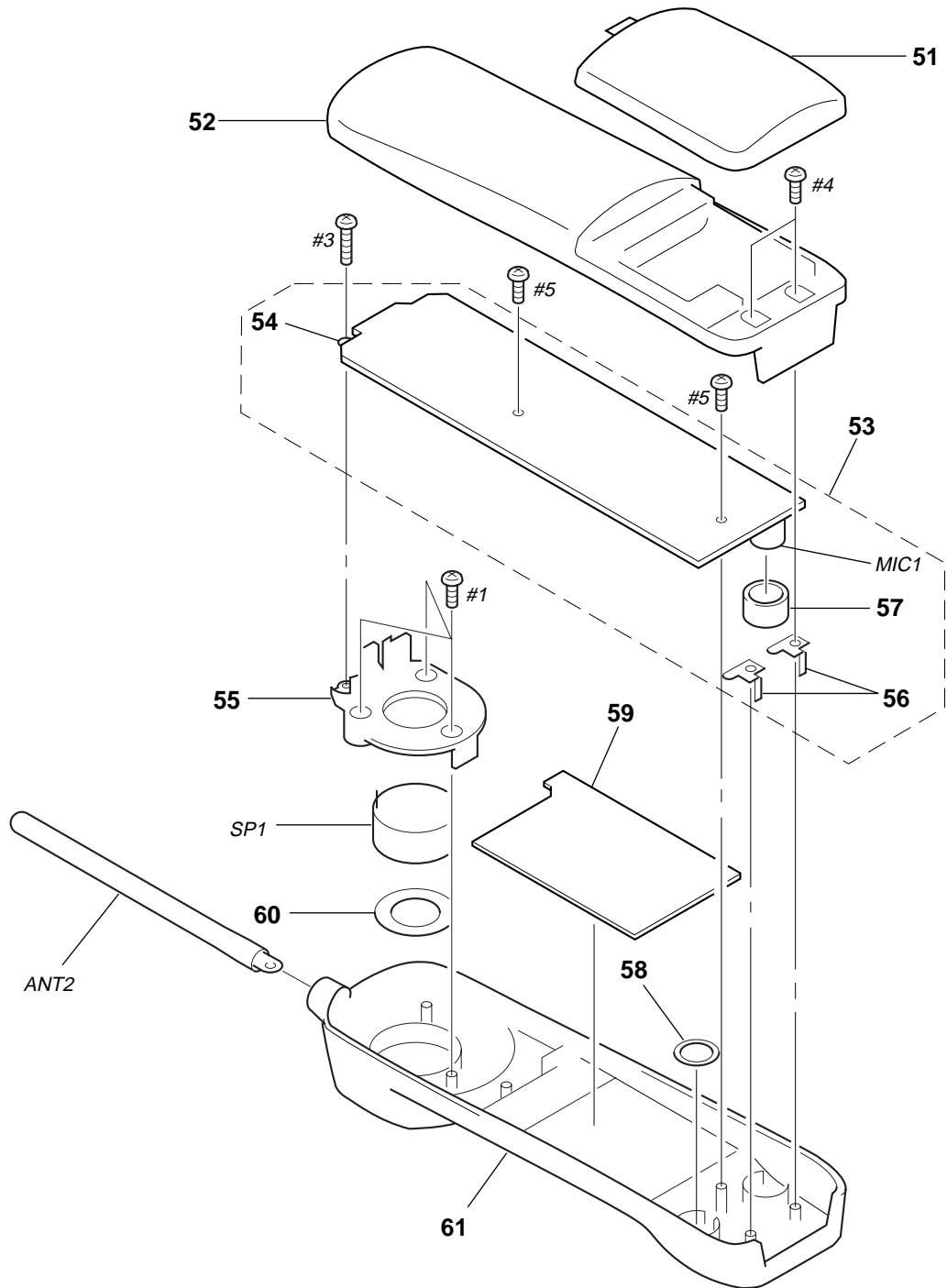

Ref. No.	Part No.	Description	Remark	Ref. No.	Part No.	Description	Remark
51	X-3377-828-1	LID ASSY (G), BATTERY CASE		* 58	3-033-764-01	CUSHION (BUZZER)	
52	3-038-923-01	CABINET (REAR)		59	1-771-708-11	SWITCH, RUBBER KEY (HAND)	
* 53	A-3622-319-A	HAND MAIN BOARD, COMPLETE		60	3-371-005-01	GASKET (RECEIVER) (TWN)	
54	3-939-070-01	TERMINAL, ANTENNA		61	3-038-925-01	CABINET (FRONT)	
55	3-038-926-01	HOLDER (SPEAKER)		ANT2	1-501-839-71	ANTENNA, HELICAL	
56	3-038-920-01	TERMINAL (CHARGE,H)		MIC1	1-542-118-11	MICROPHONE, ELECTRET CONDENSER	
57	3-935-518-01	CUSHION (MICROPHONE)		SP1	1-504-829-11	SPEAKER (2.8cm)	

BASE MAIN

**SECTION 7
ELECTRICAL PARTS LIST**

NOTE:

- Due to standardization, replacements in the parts list may be different from the parts specified in the diagrams or the components used on the set.
- -XX and -X mean standardized parts, so they may have some difference from the original one.
- RESISTORS
All resistors are in ohms.
METAL: Metal-film resistor.
METAL OXIDE: Metal oxide-film resistor.
F: nonflammable

- Items marked “**” are not stocked since they are seldom required for routine service. Some delay should be anticipated when ordering these items.
- SEMICONDUCTORS
In each case, u : μ , for example:
uA.. : μ A.. uPA.. : μ PA..
uPB.. : μ PB.. uPC.. : μ PC.. uPD.. : μ PD..
- CAPACITORS
uF : μ F
- COILS
uH : μ H

The components identified by mark Δ or dotted line with mark Δ are critical for safety. Replace only with part number specified.

When indicating parts by reference number, please include the board.

Ref. No.	Part No.	Description	Remark	Ref. No.	Part No.	Description	Remark
*	A-3622-375-A	BASE MAIN BOARD, COMPLETE *****		C113	1-163-011-11	CERAMIC CHIP 0.0015uF 10%	50V
		< BPF >		C114	1-163-809-11	CERAMIC CHIP 0.047uF 10%	25V
BPF1	1-233-692-11	FILTER, BAND PASS		C115	1-163-021-11	CERAMIC CHIP 0.01uF 10%	50V
BPF51	1-239-918-11	FILTER, BAND PASS		C116	1-163-021-11	CERAMIC CHIP 0.01uF 10%	50V
		< CAPACITOR >		C117	1-163-989-11	CERAMIC CHIP 0.033uF 10%	25V
C2	1-163-222-11	CERAMIC CHIP 5PF 0.25PF	50V	C118	1-163-021-11	CERAMIC CHIP 0.01uF 10%	50V
C5	1-163-235-11	CERAMIC CHIP 22PF 5%	50V	C122	1-163-235-11	CERAMIC CHIP 22PF 5%	50V
C8	1-163-239-11	CERAMIC CHIP 33PF 5%	50V	C123	1-165-319-11	CERAMIC CHIP 0.1uF	50V
C51	1-163-009-11	CERAMIC CHIP 0.001uF 10%	50V	C125	1-163-077-00	CERAMIC CHIP 0.1uF 10%	25V
C52	1-163-037-11	CERAMIC CHIP 0.022uF 10%	25V	C127	1-163-033-11	CERAMIC CHIP 0.022uF	50V
C53	1-163-021-11	CERAMIC CHIP 0.01uF 10%	50V	C128	1-126-963-11	ELECT 4.7uF 20%	50V
C54	1-163-009-11	CERAMIC CHIP 0.001uF 10%	50V	C129	1-163-031-11	CERAMIC CHIP 0.01uF	50V
C55	1-163-113-00	CERAMIC CHIP 68PF 5%	50V	C130	1-126-791-11	ELECT 10uF 20%	16V
C56	1-163-033-11	CERAMIC CHIP 0.022uF	50V	C131	1-165-319-11	CERAMIC CHIP 0.1uF	50V
C57	1-163-235-11	CERAMIC CHIP 22PF 5%	50V	C133	1-163-106-00	CERAMIC CHIP 36PF 5%	50V
C58	1-163-235-11	CERAMIC CHIP 22PF 5%	50V	C134	1-126-791-11	ELECT 10uF 20%	16V
C59	1-163-227-11	CERAMIC CHIP 10PF 0.5PF	50V	C135	1-163-031-11	CERAMIC CHIP 0.01uF	50V
C60	1-163-227-11	CERAMIC CHIP 10PF 0.5PF	50V	C136	1-163-035-00	CERAMIC CHIP 0.047uF	50V
C61	1-163-231-11	CERAMIC CHIP 15PF 5%	50V	C137	1-126-791-11	ELECT 10uF 20%	16V
C62	1-163-251-11	CERAMIC CHIP 100PF 5%	50V	C138	1-165-319-11	CERAMIC CHIP 0.1uF	50V
C63	1-162-587-11	CERAMIC CHIP 0.039uF 10%	25V	C201	1-136-193-11	MYLAR 0.47uF 10%	250V
C64	1-164-004-11	CERAMIC CHIP 0.1uF 10%	25V	C202	1-104-664-11	ELECT 47uF 20%	16V
C65	1-164-337-11	CERAMIC CHIP 2.2uF	16V	C204	1-109-982-11	CERAMIC CHIP 1uF 10%	10V
C66	1-163-021-11	CERAMIC CHIP 0.01uF 10%	50V	C205	1-163-019-00	CERAMIC CHIP 0.0068uF 10%	50V
C67	1-163-037-11	CERAMIC CHIP 0.022uF 10%	25V	C206	1-163-031-11	CERAMIC CHIP 0.01uF	50V
C68	1-163-031-11	CERAMIC CHIP 0.01uF	50V	C209	1-163-037-11	CERAMIC CHIP 0.022uF 10%	25V
C69	1-163-009-11	CERAMIC CHIP 0.001uF 10%	50V	C210	1-126-960-11	ELECT 1uF 20%	50V
C70	1-163-233-11	CERAMIC CHIP 18PF 5%	50V	C211	1-163-034-00	CERAMIC CHIP 0.033uF	50V
C71	1-163-224-11	CERAMIC CHIP 7PF 0.25PF	50V	C212	1-126-961-11	ELECT 2.2uF 20%	50V
C72	1-163-033-11	CERAMIC CHIP 0.022uF	50V	C213	1-126-961-11	ELECT 2.2uF 20%	50V
C101	1-165-319-11	CERAMIC CHIP 0.1uF	50V	C301	1-164-336-11	CERAMIC CHIP 0.33uF	25V
C102	1-163-239-11	CERAMIC CHIP 33PF 5%	50V	C302	1-165-319-11	CERAMIC CHIP 0.1uF	50V
C103	1-163-106-00	CERAMIC CHIP 36PF 5%	50V	C303	1-126-964-11	ELECT 10uF 20%	50V
C105	1-163-243-11	CERAMIC CHIP 47PF 5%	50V	C304	1-164-336-11	CERAMIC CHIP 0.33uF	25V
C106	1-163-137-00	CERAMIC CHIP 680PF 5%	50V	C305	1-163-033-11	CERAMIC CHIP 0.022uF	50V
C107	1-165-319-11	CERAMIC CHIP 0.1uF	50V	C306	1-163-033-11	CERAMIC CHIP 0.022uF	50V
C108	1-126-964-11	ELECT 10uF 20%	50V	C401	1-163-031-11	CERAMIC CHIP 0.01uF	50V
C109	1-163-021-11	CERAMIC CHIP 0.01uF 10%	50V	C502	1-126-934-11	ELECT 220uF 20%	10V
C110	1-163-989-11	CERAMIC CHIP 0.033uF 10%	25V	C503	1-163-031-11	CERAMIC CHIP 0.01uF	50V
C111	1-164-161-11	CERAMIC CHIP 0.0022uF 10%	100V	C504	1-163-104-00	CERAMIC CHIP 30PF 5%	50V
C112	1-163-037-11	CERAMIC CHIP 0.022uF 10%	25V	C505	1-163-137-00	CERAMIC CHIP 680PF 5%	50V
				C506	1-163-104-00	CERAMIC CHIP 30PF 5%	50V

Ref. No.	Part No.	Description	Remark	Ref. No.	Part No.	Description	Remark
		< FILTER >					
CF101	1-767-418-11	FILTER, CERAMIC		JR20	1-216-295-00	SHORT 0	
CF102	1-577-070-11	FILTER, CERAMIC		JR21	1-216-295-00	SHORT 0	
		< CONNECTOR >		JR22	1-216-295-00	SHORT 0	
* CN301	1-506-984-11	PIN, CONNECTOR (PC BOARD) 2P		JR24	1-216-296-00	SHORT 0	
		< DIODE >		JR205	1-216-295-00	SHORT 0	
D1	8-719-991-33	DIODE 1SS133T-77				< COIL >	
D51	8-719-055-14	DIODE KV1832CTR3		L1	1-469-453-21	INDUCTOR 0.68uH	
D101	8-719-991-33	DIODE 1SS133T-77		L2	1-412-255-11	INDUCTOR 0.22uH	
D201	8-719-991-33	DIODE 1SS133T-77		L3	1-469-546-21	INDUCTOR 0.56uH	
D203	8-719-109-88	DIODE RD5.6ES-T1B		L51	1-469-455-21	INDUCTOR 1uH	
		< DIODE >		L52	1-411-884-11	COIL, OSC	
D204	8-719-109-88	DIODE RD5.6ES-T1B		L101	1-409-798-11	COIL, OSC	
D205	8-719-050-65	DIODE S1ZB60-TL		L301	1-469-456-21	INDUCTOR 1.2uH	
D206	8-719-109-97	DIODE RD6.8ESB2		L302	1-469-456-21	INDUCTOR 1.2uH	
D207	8-719-109-97	DIODE RD6.8ESB2		L501	1-469-455-21	INDUCTOR 1uH	
D208	8-719-109-97	DIODE RD6.8ESB2				< JACK >	
		< DIODE >		MJ201	1-766-250-11	JACK, MODULAR (2C) 6P (LINE)	
D301	8-719-109-97	DIODE RD6.8ESB2				< PHOTO TRANSISTOR >	
D401	8-719-059-87	LED SLR-342VRTB7 (CHARGE)		PH201	8-719-802-04	PHOTO TRANSISTOR TLP521-1-GR	
D501	8-719-991-33	DIODE 1SS133T-77		PH202	8-719-024-09	PHOTO COUPLER PS2532-1	
		< COIL >				< TRANSISTOR >	
FL101	1-416-311-21	COIL, IFT		Q51	8-729-031-85	TRANSISTOR 2SC4365-34-TB	
		< IC >		Q52	8-729-031-86	TRANSISTOR 2SC3142-J3J4-TB	
IC101	8-759-361-65	IC TB31223F		Q54	8-729-026-49	TRANSISTOR 2SA1037AK-T146-QR	
IC301	8-759-598-14	IC TK61042UTL		Q201	8-729-120-28	TRANSISTOR 2SC1623-L5L6	
IC302	8-759-708-05	IC TA78L005AP-TPE6		Q202	8-729-120-28	TRANSISTOR 2SC1623-L5L6	
IC501	8-759-598-98	IC SB662104A-4L43-TLM		Q203	8-729-032-66	TRANSISTOR 2SC5069-TD	
		< JACK >		Q302	8-729-120-28	TRANSISTOR 2SC1623-L5L6	
J301	1-778-380-11	JACK, DC (POLARITY UNIFIED TYPE)	(DC IN 9V)	Q401	8-729-120-28	TRANSISTOR 2SC1623-L5L6	
		< JUMPER RESISTOR >		Q402	8-729-106-68	TRANSISTOR 2SD1664-T100-Q	
JR1	1-216-295-00	SHORT 0		Q403	8-729-120-28	TRANSISTOR 2SC1623-L5L6	
JR2	1-216-295-00	SHORT 0				< RESISTOR >	
JR3	1-216-296-00	SHORT 0		R51	1-216-057-00	METAL CHIP 2.2K 5% 1/10W	
JR4	1-216-295-00	SHORT 0		R52	1-216-073-00	METAL CHIP 10K 5% 1/10W	
JR5	1-216-296-00	SHORT 0		R53	1-216-037-00	METAL CHIP 330 5% 1/10W	
		< JUMPER RESISTOR >		R54	1-216-025-11	RES,CHIP 100 5% 1/10W	
JR7	1-216-296-00	SHORT 0		R55	1-216-057-00	METAL CHIP 2.2K 5% 1/10W	
JR8	1-216-296-00	SHORT 0		R57	1-216-085-00	METAL CHIP 33K 5% 1/10W	
JR10	1-216-295-00	SHORT 0		R58	1-216-049-11	RES,CHIP 1K 5% 1/10W	
JR11	1-216-295-00	SHORT 0		R63	1-216-085-00	METAL CHIP 33K 5% 1/10W	
JR12	1-216-296-00	SHORT 0		R64	1-216-073-00	METAL CHIP 10K 5% 1/10W	
		< JUMPER RESISTOR >		R65	1-216-069-00	METAL CHIP 6.8K 5% 1/10W	
JR15	1-216-295-00	SHORT 0		R66	1-216-113-00	METAL CHIP 470K 5% 1/10W	
JR16	1-216-295-00	SHORT 0		R68	1-216-097-11	RES,CHIP 100K 5% 1/10W	
JR17	1-216-296-00	SHORT 0		R69	1-216-057-00	METAL CHIP 2.2K 5% 1/10W	
JR18	1-216-296-00	SHORT 0		R101	1-216-095-00	METAL CHIP 82K 5% 1/10W	
JR19	1-216-296-00	SHORT 0		R102	1-216-105-11	RES,CHIP 220K 5% 1/10W	
		< JUMPER RESISTOR >		R103	1-216-105-11	RES,CHIP 220K 5% 1/10W	

BASE MAIN

HAND MAIN

Ref. No.	Part No.	Description	Remark
R104	1-216-105-11	RES,CHIP 220K	5% 1/10W
R105	1-216-107-00	METAL CHIP 270K	5% 1/10W
R106	1-216-095-00	METAL CHIP 82K	5% 1/10W
R107	1-216-081-00	METAL CHIP 22K	5% 1/10W
R111	1-216-109-00	METAL CHIP 330K	5% 1/10W
R112	1-216-097-11	RES,CHIP 100K	5% 1/10W
R113	1-216-065-11	RES,CHIP 4.7K	5% 1/10W
R114	1-216-077-11	RES,CHIP 15K	5% 1/10W
R115	1-216-089-11	RES,CHIP 47K	5% 1/10W
R116	1-216-689-11	METAL CHIP 39K	0.5% 1/10W
R118	1-216-073-00	METAL CHIP 10K	5% 1/10W
R119	1-216-246-00	RES,CHIP 100K	5% 1/8W
R123	1-216-109-00	METAL CHIP 330K	5% 1/10W
R126	1-216-057-00	METAL CHIP 2.2K	5% 1/10W
R136	1-216-073-00	METAL CHIP 10K	5% 1/10W
R142	1-216-081-00	METAL CHIP 22K	5% 1/10W
R151	1-216-073-00	METAL CHIP 10K	5% 1/10W
R201	1-215-861-00	METAL OXIDE 47	5% 1W F
R202	1-215-877-11	METAL OXIDE 22K	5% 1W F
R204	1-216-077-11	RES,CHIP 15K	5% 1/10W
R205	1-216-246-00	RES,CHIP 100K	5% 1/8W
R206	1-216-174-00	RES,CHIP 100	5% 1/8W
R207	1-216-049-11	RES,CHIP 1K	5% 1/10W
R208	1-216-053-00	METAL CHIP 1.5K	5% 1/10W
R209	1-216-065-11	RES,CHIP 4.7K	5% 1/10W
R210	1-216-041-00	METAL CHIP 470	5% 1/10W
R211	1-216-029-00	METAL CHIP 150	5% 1/10W
R212	1-216-176-11	RES,CHIP 120	5% 1/8W
R213	1-216-029-00	METAL CHIP 150	5% 1/10W
R215	1-216-085-00	METAL CHIP 33K	5% 1/10W
R216	1-215-859-00	METAL OXIDE 22	5% 1W F
R217	1-216-037-00	METAL CHIP 330	5% 1/10W
R301	1-216-033-00	METAL CHIP 220	5% 1/10W
R305	1-216-097-11	RES,CHIP 100K	5% 1/10W
R306	1-216-097-11	RES,CHIP 100K	5% 1/10W
R307	1-216-113-00	METAL CHIP 470K	5% 1/10W
R308	1-216-097-11	RES,CHIP 100K	5% 1/10W
R309	1-216-097-11	RES,CHIP 100K	5% 1/10W
R310	1-216-065-11	RES,CHIP 4.7K	5% 1/10W
R401	1-216-190-00	RES,CHIP 470	5% 1/8W
R402	1-216-174-00	RES,CHIP 100	5% 1/8W
R403	1-216-005-00	METAL CHIP 15	5% 1/10W
R404	1-216-005-00	METAL CHIP 15	5% 1/10W
R405	1-216-025-11	RES,CHIP 100	5% 1/10W
R406	1-216-073-00	METAL CHIP 10K	5% 1/10W
R408	1-216-041-00	METAL CHIP 470	5% 1/10W
R409	1-216-017-11	RES,CHIP 47	5% 1/10W
R411	1-216-065-11	RES,CHIP 4.7K	5% 1/10W
R412	1-249-417-11	CARBON 1K	5% 1/4W
R503	1-216-073-00	METAL CHIP 10K	5% 1/10W
R505	1-216-049-11	RES,CHIP 1K	5% 1/10W
R506	1-216-049-11	RES,CHIP 1K	5% 1/10W
R507	1-216-049-11	RES,CHIP 1K	5% 1/10W

Ref. No.	Part No.	Description	Remark
R508	1-216-097-11	RES,CHIP 100K	5% 1/10W
R509	1-216-121-11	RES,CHIP 1M	5% 1/10W
R510	1-216-246-00	RES,CHIP 100K	5% 1/8W
R513	1-216-075-00	METAL CHIP 12K	5% 1/10W
R514	1-216-073-00	METAL CHIP 10K	5% 1/10W
R515	1-216-057-00	METAL CHIP 2.2K	5% 1/10W
R522	1-216-097-11	RES,CHIP 100K	5% 1/10W
R523	1-216-097-11	RES,CHIP 100K	5% 1/10W
R524	1-216-097-11	RES,CHIP 100K	5% 1/10W
R525	1-216-097-11	RES,CHIP 100K	5% 1/10W
R526	1-216-097-11	RES,CHIP 100K	5% 1/10W
R527	1-216-097-11	RES,CHIP 100K	5% 1/10W
R528	1-216-097-11	RES,CHIP 100K	5% 1/10W
< VARIABLE RESISTOR >			
RV101	1-241-770-11	RES, ADJ, CARBON 1M	
< SWITCH >			
S301	1-571-977-11	SWITCH, TACTILE (HANDSET LOCATOR)	
S302	1-692-991-11	SWITCH, SLIDE (DIAL MODE)	
< TRANSFORMER >			
T201	1-431-832-11	TRANSFORMER, LINE	
< VARISTOR >			
VDR201	1-801-025-21	VARISTOR ERZV07D201	
< VIBRATOR >			
X101	1-760-325-11	VIBRATOR, CRYSTAL (10.22MHz)	
X501	1-760-324-11	VIBRATOR, CRYSTAL (4.048MHz)	

*	A-3622-319-A	HAND MAIN BOARD, COMPLETE	*****
	3-038-920-01	TERMINAL (CHARGE,H)	
	3-935-518-01	CUSHION (MICROPHONE)	
	3-939-070-01	TERMINAL, ANTENNA	
< BPF >			
BPF1	1-234-163-41	FILTER, BAND PASS	
BPF51	1-239-916-11	FILTER, BAND PASS	
< BUZZER >			
BZ301	1-544-603-21	BUZZER	
< CAPACITOR >			
C1	1-163-237-11	CERAMIC CHIP 27PF	5% 50V
C3	1-163-033-11	CERAMIC CHIP 0.022uF	50V
C51	1-163-009-11	CERAMIC CHIP 0.001uF	10% 50V
C52	1-163-037-11	CERAMIC CHIP 0.022uF	10% 25V
C53	1-163-021-11	CERAMIC CHIP 0.01uF	10% 50V

Ref. No.	Part No.	Description	Remark	Ref. No.	Part No.	Description	Remark
C54	1-163-009-11	CERAMIC CHIP	0.001uF 10% 50V	C149	1-163-021-11	CERAMIC CHIP	0.01uF 10% 50V
C55	1-163-243-11	CERAMIC CHIP	47PF 5% 50V	C201	1-163-035-00	CERAMIC CHIP	0.047uF 50V
C56	1-163-033-11	CERAMIC CHIP	0.022uF 50V	C202	1-164-336-11	CERAMIC CHIP	0.33uF 25V
C57	1-163-235-11	CERAMIC CHIP	22PF 5% 50V	C203	1-163-075-00	CERAMIC CHIP	0.047uF 50V
C58	1-163-235-11	CERAMIC CHIP	22PF 5% 50V	C205	1-163-033-11	CERAMIC CHIP	0.022uF 50V
C59	1-163-227-11	CERAMIC CHIP	10PF 0.5PF 50V	C207	1-163-035-00	CERAMIC CHIP	0.047uF 50V
C60	1-163-227-11	CERAMIC CHIP	10PF 0.5PF 50V	C208	1-163-035-00	CERAMIC CHIP	0.047uF 50V
C61	1-163-241-11	CERAMIC CHIP	39PF 5% 50V	C210	1-163-009-11	CERAMIC CHIP	0.001uF 10% 50V
C62	1-163-243-11	CERAMIC CHIP	47PF 5% 50V	C501	1-164-161-11	CERAMIC CHIP	0.0022uF 10% 100V
C63	1-162-587-11	CERAMIC CHIP	0.039uF 10% 25V	C505	1-163-017-00	CERAMIC CHIP	0.0047uF 5% 50V
C64	1-164-004-11	CERAMIC CHIP	0.1uF 10% 25V	C511	1-163-104-00	CERAMIC CHIP	30PF 5% 50V
C65	1-164-337-11	CERAMIC CHIP	2.2uF 16V	C513	1-163-104-00	CERAMIC CHIP	30PF 5% 50V
C66	1-163-021-11	CERAMIC CHIP	0.01uF 10% 50V	C514	1-163-031-11	CERAMIC CHIP	0.01uF 50V
C67	1-164-004-11	CERAMIC CHIP	0.1uF 10% 25V	C515	1-107-682-11	CERAMIC CHIP	1uF 10% 16V
C101	1-165-319-11	CERAMIC CHIP	0.1uF 50V	C516	1-163-009-11	CERAMIC CHIP	0.001uF 10% 50V
C102	1-163-241-11	CERAMIC CHIP	39PF 5% 50V	< FILTER >			
C103	1-163-239-11	CERAMIC CHIP	33PF 5% 50V	CF101	1-767-418-11	FILTER, CERAMIC	
C105	1-163-243-11	CERAMIC CHIP	47PF 5% 50V	CF102	1-577-070-11	FILTER, CERAMIC	
C106	1-163-137-00	CERAMIC CHIP	680PF 5% 50V	< CONNECTOR >			
C107	1-165-319-11	CERAMIC CHIP	0.1uF 50V	* CN101	1-506-984-11	PIN, CONNECTOR (PC BOARD) 2P	
C108	1-126-791-11	ELECT	10uF 20% 16V	CN201	1-766-180-11	PIN, CONNECTOR (PC BOARD) 2P	
C109	1-163-021-11	CERAMIC CHIP	0.01uF 10% 50V	* CN202	1-506-984-11	PIN, CONNECTOR (PC BOARD) 2P	
C110	1-163-809-11	CERAMIC CHIP	0.047uF 10% 25V	< DIODE >			
C111	1-163-989-11	CERAMIC CHIP	0.033uF 10% 25V	D51	8-719-055-14	DIODE KV1832CTR3	
C112	1-163-021-11	CERAMIC CHIP	0.01uF 10% 50V	D202	8-719-941-04	DIODE SB007-03CP-TB	
C113	1-163-809-11	CERAMIC CHIP	0.047uF 10% 25V	D301	8-719-914-43	DIODE DAN202K-T-146	
C115	1-164-161-11	CERAMIC CHIP	0.0022uF 10% 100V	D501	8-719-059-87	LED SLR-342VRTB7 (TALK/BATT LOW)	
C116	1-163-021-11	CERAMIC CHIP	0.01uF 10% 50V	D502	8-719-914-43	DIODE DAN202K-T-146	
C117	1-164-004-11	CERAMIC CHIP	0.1uF 10% 25V	D504	8-719-941-04	DIODE SB007-03CP-TB	
C118	1-163-021-11	CERAMIC CHIP	0.01uF 10% 50V	< COIL >			
C119	1-163-033-11	CERAMIC CHIP	0.022uF 50V	FL101	1-416-311-21	COIL, IFT	
C120	1-163-033-11	CERAMIC CHIP	0.022uF 50V	< IC >			
C121	1-165-319-11	CERAMIC CHIP	0.1uF 50V	IC101	8-759-462-29	IC TB31224F	
C122	1-163-235-11	CERAMIC CHIP	22PF 5% 50V	IC201	8-759-560-84	IC TK61027UTL	
C123	1-165-319-11	CERAMIC CHIP	0.1uF 50V	IC501	8-759-598-97	IC SH66356C-4L44	
C124	1-164-161-11	CERAMIC CHIP	0.0022uF 10% 100V	< JUMPER RESISTOR >			
C125	1-165-319-11	CERAMIC CHIP	0.1uF 50V	JR101	1-216-296-00	SHORT 0	
C127	1-163-033-11	CERAMIC CHIP	0.022uF 50V	JR102	1-216-296-00	SHORT 0	
C128	1-126-791-11	ELECT	10uF 20% 16V	JR103	1-216-296-00	SHORT 0	
C129	1-163-087-00	CERAMIC CHIP	4PF 50V	JR105	1-216-295-00	SHORT 0	
C130	1-126-791-11	ELECT	10uF 20% 16V	JR106	1-216-296-00	SHORT 0	
C131	1-165-319-11	CERAMIC CHIP	0.1uF 50V	JR108	1-216-296-00	SHORT 0	
C132	1-126-791-11	ELECT	10uF 20% 16V	JR110	1-216-296-00	SHORT 0	
C133	1-165-319-11	CERAMIC CHIP	0.1uF 50V	JR111	1-216-295-00	SHORT 0	
C134	1-126-924-11	ELECT	330uF 20% 6.3V	JR112	1-216-295-00	SHORT 0	
C136	1-163-237-11	CERAMIC CHIP	27PF 5% 50V	JR113	1-216-295-00	SHORT 0	
C138	1-163-021-11	CERAMIC CHIP	0.01uF 10% 50V				
C139	1-163-237-11	CERAMIC CHIP	27PF 5% 50V				
C140	1-126-791-11	ELECT	10uF 20% 16V				
C141	1-163-021-11	CERAMIC CHIP	0.01uF 10% 50V				
C142	1-164-489-11	CERAMIC CHIP	0.22uF 10% 16V				
C143	1-162-638-11	CERAMIC CHIP	1uF 16V				
C148	1-163-009-11	CERAMIC CHIP	0.001uF 10% 50V				

HAND MAIN

Ref. No.	Part No.	Description	Remark	Ref. No.	Part No.	Description	Remark
JR114	1-216-296-00	SHORT	0	R65	1-216-069-00	METAL CHIP 6.8K	5% 1/10W
JR115	1-216-296-00	SHORT	0	R66	1-216-107-00	METAL CHIP 270K	5% 1/10W
JR117	1-216-296-00	SHORT	0	R68	1-216-097-11	RES,CHIP 100K	5% 1/10W
JR120	1-216-296-00	SHORT	0	R69	1-216-057-00	METAL CHIP 2.2K	5% 1/10W
JR124	1-216-296-00	SHORT	0	R101	1-216-093-11	RES,CHIP 68K	5% 1/10W
JR126	1-216-296-00	SHORT	0	R102	1-216-105-11	RES,CHIP 220K	5% 1/10W
JR127	1-216-296-00	SHORT	0	R103	1-216-105-11	RES,CHIP 220K	5% 1/10W
JR128	1-216-296-00	SHORT	0	R104	1-216-105-11	RES,CHIP 220K	5% 1/10W
JR129	1-216-296-00	SHORT	0	R105	1-216-109-00	METAL CHIP 330K	5% 1/10W
JR130	1-216-296-00	SHORT	0	R106	1-216-049-11	RES,CHIP 1K	5% 1/10W
JR131	1-216-296-00	SHORT	0	R107	1-216-077-11	RES,CHIP 15K	5% 1/10W
JR132	1-216-296-00	SHORT	0	R108	1-216-246-00	RES,CHIP 100K	5% 1/8W
JR133	1-216-295-00	SHORT	0	R109	1-216-097-11	RES,CHIP 100K	5% 1/10W
JR134	1-216-296-00	SHORT	0	R110	1-216-097-11	RES,CHIP 100K	5% 1/10W
JR136	1-216-296-00	SHORT	0	R111	1-216-109-00	METAL CHIP 330K	5% 1/10W
JR137	1-216-296-00	SHORT	0	R112	1-216-093-11	RES,CHIP 68K	5% 1/10W
JR138	1-216-296-00	SHORT	0	R113	1-216-069-00	METAL CHIP 6.8K	5% 1/10W
JR140	1-216-296-00	SHORT	0	R114	1-216-093-11	RES,CHIP 68K	5% 1/10W
		< COIL >		R115	1-216-085-00	METAL CHIP 33K	5% 1/10W
L1	1-469-456-21	INDUCTOR	1.2uH	R116	1-216-097-11	RES,CHIP 100K	5% 1/10W
L2	1-469-456-21	INDUCTOR	1.2uH	R118	1-216-073-00	METAL CHIP 10K	5% 1/10W
L4	1-469-547-21	INDUCTOR	0.1uH	R119	1-216-121-11	RES,CHIP 1M	5% 1/10W
L52	1-411-883-11	COIL, OSC		R120	1-216-073-00	METAL CHIP 10K	5% 1/10W
L101	1-469-548-21	INDUCTOR	0.33uH	R121	1-216-081-00	METAL CHIP 22K	5% 1/10W
L102	1-409-670-11	COIL, OSC		R123	1-216-073-00	METAL CHIP 10K	5% 1/10W
		< MICROPHONE >		R126	1-216-037-00	METAL CHIP 330	5% 1/10W
MIC1	1-542-118-11	MICROPHONE, ELECTRET CONDENSER		R130	1-216-077-11	RES,CHIP 15K	5% 1/10W
		< TRANSISTOR >		R141	1-216-206-00	RES,CHIP 2.2K	5% 1/8W
Q51	8-729-031-85	TRANSISTOR 2SC4365-34-TB		R142	1-216-057-00	METAL CHIP 2.2K	5% 1/10W
Q52	8-729-031-86	TRANSISTOR 2SC3142-J3J4-TB		R144	1-216-061-00	METAL CHIP 3.3K	5% 1/10W
Q54	8-729-026-49	TRANSISTOR 2SA1037AK-T146-QR		R201	1-216-073-00	METAL CHIP 10K	5% 1/10W
Q201	8-729-120-28	TRANSISTOR 2SC1623-L5L6		R202	1-216-113-00	METAL CHIP 470K	5% 1/10W
Q301	8-729-026-49	TRANSISTOR 2SA1037AK-T146-QR		R203	1-216-097-11	RES,CHIP 100K	5% 1/10W
Q501	8-729-026-49	TRANSISTOR 2SA1037AK-T146-QR		R204	1-216-097-11	RES,CHIP 100K	5% 1/10W
Q502	8-729-026-49	TRANSISTOR 2SA1037AK-T146-QR		R205	1-216-073-00	METAL CHIP 10K	5% 1/10W
		< RESISTOR >		R206	1-216-222-00	RES,CHIP 10K	5% 1/8W
R1	1-216-093-11	RES,CHIP 68K	5% 1/10W	R301	1-216-057-00	METAL CHIP 2.2K	5% 1/10W
R2	1-216-021-00	METAL CHIP 68	5% 1/10W	R501	1-216-073-00	METAL CHIP 10K	5% 1/10W
R3	1-216-025-11	RES,CHIP 100	5% 1/10W	R502	1-216-073-00	METAL CHIP 10K	5% 1/10W
R51	1-216-023-00	METAL CHIP 82	5% 1/10W	R504	1-216-073-00	METAL CHIP 10K	5% 1/10W
R52	1-216-073-00	METAL CHIP 10K	5% 1/10W	R505	1-216-073-00	METAL CHIP 10K	5% 1/10W
R53	1-216-037-00	METAL CHIP 330	5% 1/10W	R506	1-216-097-11	RES,CHIP 100K	5% 1/10W
R54	1-216-025-11	RES,CHIP 100	5% 1/10W	R507	1-216-041-00	METAL CHIP 470	5% 1/10W
R55	1-216-057-00	METAL CHIP 2.2K	5% 1/10W	R508	1-216-097-11	RES,CHIP 100K	5% 1/10W
R57	1-216-085-00	METAL CHIP 33K	5% 1/10W	R509	1-216-097-11	RES,CHIP 100K	5% 1/10W
R58	1-216-049-11	RES,CHIP 1K	5% 1/10W	R510	1-216-097-11	RES,CHIP 100K	5% 1/10W
R63	1-216-085-00	METAL CHIP 33K	5% 1/10W	R511	1-216-097-11	RES,CHIP 100K	5% 1/10W
R64	1-216-073-00	METAL CHIP 10K	5% 1/10W	R512	1-216-049-11	RES,CHIP 1K	5% 1/10W
				R513	1-216-049-11	RES,CHIP 1K	5% 1/10W
				R514	1-216-049-11	RES,CHIP 1K	5% 1/10W
				R515	1-216-073-00	METAL CHIP 10K	5% 1/10W
				R518	1-216-073-00	METAL CHIP 10K	5% 1/10W
				R519	1-216-073-00	METAL CHIP 10K	5% 1/10W

Ref. No.	Part No.	Description	Remark
R520	1-216-121-11	RES,CHIP 1M	5% 1/10W
R521	1-216-097-11	RES,CHIP 100K	5% 1/10W
R522	1-216-129-00	METAL CHIP 2.2M	5% 1/10W
R532	1-216-073-00	METAL CHIP 10K	5% 1/10W
R533	1-216-097-11	RES,CHIP 100K	5% 1/10W
R534	1-216-097-11	RES,CHIP 100K	5% 1/10W
R541	1-216-117-00	METAL CHIP 680K	5% 1/10W
R555	1-216-097-11	RES,CHIP 100K	5% 1/10W
< VARIABLE RESISTOR >			
RV101	1-241-770-11	RES, ADJ, CARBON 1M	
< SWITCH >			
S101	1-692-989-11	SWITCH, SLIDE (VOL)	
< VIBRATOR >			
X101	1-760-326-11	VIBRATOR, CRYSTAL (10.2MHz)	
X501	1-760-324-11	VIBRATOR, CRYSTAL (4.048MHz)	

MISCELLANEOUS			

59	1-771-708-11	SWITCH, RUBBER KEY (HAND) (HANDSET)	
ANT1	1-754-075-21	ANTENNA, TELESCOPIC (BASE UNIT)	
ANT2	1-501-839-71	ANTENNA, HELICAL (HANDSET)	
SP1	1-504-829-11	SPEAKER (2.8cm) (HANDSET)	

ACCESSORIES & PACKING MATERIALS			

△	1-475-210-12	ADAPTOR, AC (AC-T56)	
	1-528-709-31	BATTERY, NICKEL CADMIUM (BP-T16)	
	1-696-454-11	CORD (WITH MODULAR PLUG) (LINE) (215cm)	
	3-026-932-01	LABEL (ADDRESS,B)	
	3-867-032-51	MANUAL, INSTRUCTION (ENGLISH, TRADITIONAL CHINESE)	
	X-3368-367-1	SCREW ASSY (for WALL HOOK)	

HARDWARE LIST			

#1	7-685-134-19	SCREW +BTP 2.6X8 TYPE2 N-S	
#2	7-685-647-79	SCREW +P 3X10 TYPE2 NON-SLIT	
#3	7-685-136-19	SCREW +BTP 2.6X12 TYPE2 N-S	
#4	7-685-135-19	SCREW +BTP 2.6X10 TYPE2 N-S	
#5	7-685-134-19	SCREW +P 2.6X8 TYPE2 NON-SLIT	

The components identified by mark △ or dotted line with mark △ are critical for safety. Replace only with part number specified.

