

SPP-S9101

SERVICE MANUAL

*US Model
Canadian Model*



SPECIFICATIONS

General

Spread method
Direct-Sequence Spread-Spectrum

Access method
FDMA-TDD

Operation frequency
902 - 928 MHz

Operating channel
14 channels

Dial signal
Tone, 10 PPS (pulse) selectable

Handset

Power source
Rechargeable battery pack BP-T31

Battery charging time
Approx. 12 hours

Battery life
Standby: Approx. 7 days
Talk: Approx. 6 hours

Dimensions
Approx. 56 x 183 x 55 mm (w/h/d),
antenna excluded
(approx. 2 1/4 x 7 1/4 x 2 1/4 inches)
Antenna: Approx. 75 mm
(approx. 3 inches)

Mass
Approx. 255 g (approx. 9 oz), battery
included

Base unit

Power source
DC 9V from AC power adaptor

Battery charging time
Approx. 24 hours

Dimensions
Approx. 123 x 70 x 225 mm (w/h/d),
antenna excluded
(approx. 4 7/8 x 2 7/8 x 8 7/8 inches)
Antenna: Approx. 165 mm
(approx. 6 1/2 inches)

Mass
Approx. 355 g (approx. 13 oz), wall bracket
excluded

Design and specifications are subject to
change without notice.

CORDLESS TELEPHONE

SONY®



TABLE OF CONTENTS

1. GENERAL	3
2. DISASSEMBLY	
2-1. Battery Case LID (Handset)	12
2-2. Cabinet (Rear) (Handset)	12
2-3. Hand Main Board (Handset)	12
2-4. Cabinet and Boards (Base Unit)	12
3. 900 MHz SYSTEM OPERATION	
3-1. Access Method	13
3-2. Protocol	13
4. TEST MODE	
4-1. Base Unit Test Mode A	16
4-2. Base Unit Test Mode B	17
4-3. Handset Test Mode	18
4-4. RF Testing	19
5. ELECTRICAL ADJUSTMENTS	
5-1. Base Unit Section	22
5-2. Handset Section	23
6. DIAGRAMS	
6-1. IC Block Diagrams	25
6-2. Printed Wiring Boards – Base Unit/LED Section –	26
6-3. Schematic Diagram – Base Unit (1/2) Section –	28
6-4. Schematic Diagrams – Base Unit (2/2)/LED Section –	29
6-5. Printed Wiring Board – Handset Section –	30
6-6. Schematic Diagram – Handset Section –	31
6-7. IC Pin Functions	32
7. EXPLODED VIEWS	
7-1. Handset Section	35
7-2. Base Unit Section	36
8. ELECTRICAL PARTS LIST	37

Notes on chip component replacement

- Never reuse a disconnected chip component.
- Notice that the minus side of a tantalum capacitor may be damaged by heat.

SAFETY-RELATED COMPONENT WARNING !!

COMPONENTS IDENTIFIED BY MARK \triangle OR DOTTED LINE WITH MARK \triangle ON THE SCHEMATIC DIAGRAMS AND IN THE PARTS LIST ARE CRITICAL TO SAFE OPERATION. REPLACE THESE COMPONENTS WITH SONY PARTS WHOSE PART NUMBERS APPEAR AS SHOWN IN THIS MANUAL OR IN SUPPLEMENTS PUBLISHED BY SONY.

ATTENTION AU COMPOSANT AYANT RAPPORT À LA SÉCURITÉ!!

LES COMPOSANTS IDENTIFIÉS PAR UNE MARQUE \triangle SUR LES DIAGRAMMES SCHÉMATIQUES ET LA LISTE DES PIÈCES SONT CRITIQUES POUR LA SÉCURITÉ DE FONCTIONNEMENT. NE REMPLACER CES COMPOSANTS QUE PAR DES PIÈCES SONY DONT LES NUMÉROS SONT DONNÉS DANS CE MANUEL OU DANS LES SUPPLÉMENTS PUBLIÉS PAR SONY.

Step 2

Setting up the base unit

- Do the following steps:
- Choose the best location
 - Connect the base unit
 - Choose the dialing mode

Choose the best location

Where you place the base unit affects the reception quality of the handset.

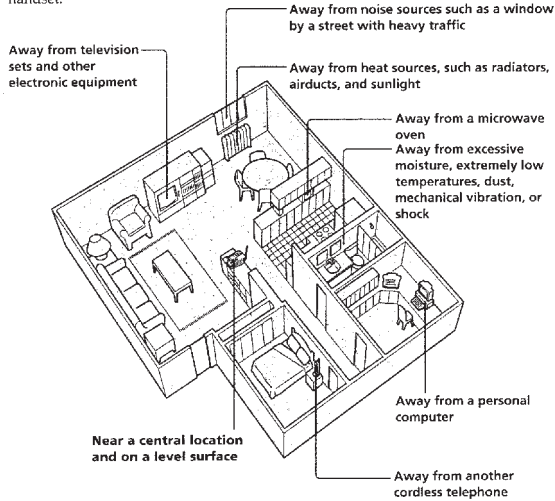

CAUTION:

- Should you experience intermittent loss of audio during a conversation, try moving closer to the base or move base unit away from other noise sources.
- The cordless telephone operates at a frequency that may cause interference to nearby TVs and VCRs; the base unit should not be placed near or on the top of a TV or VCR; and, if interference is experienced, moving the cordless telephone farther away from the TV or VCR will often reduce or eliminate the interference.

Connect the base unit

If you want to hang the base unit on the wall, see page 40.

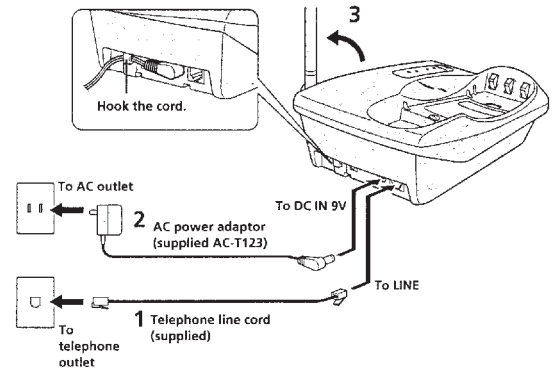

- 1 Connect the telephone line cord to the LINE jack and to a telephone outlet.
- 2 Connect the AC power adaptor to the DC IN 9V jack and to an AC outlet.
- 3 Raise the antenna. Make sure it points toward the ceiling.

continued

Step 2: Setting up the base unit (continued)

Notes

- Use only the supplied AC-T123 AC power adaptor. Do not use any other AC power adaptor.
- Connect the AC power adaptor to a continuous power supply.
- Place the base unit close to the AC outlet so that you can unplug the AC power adaptor easily.

Polarity of the plug



Tip

If your telephone outlet is not modular, contact your telephone service company for assistance.

Modular



Choose the dialing mode

For the telephone to work properly, select an appropriate dialing mode (tone or pulse).

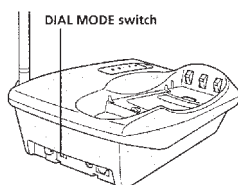

Depending on your dialing system, set the DIAL MODE switch as follows:

If your dialing system is	Set the switch to
Tone	T
Pulse	P

If you aren't sure of your dialing system

Make a trial call with the DIAL MODE switch set to T. If the call connects, leave the switch as is; otherwise, set to P.

Step 3

Preparing the battery pack

Charge the battery pack for more than 12 hours before you start using your phone.

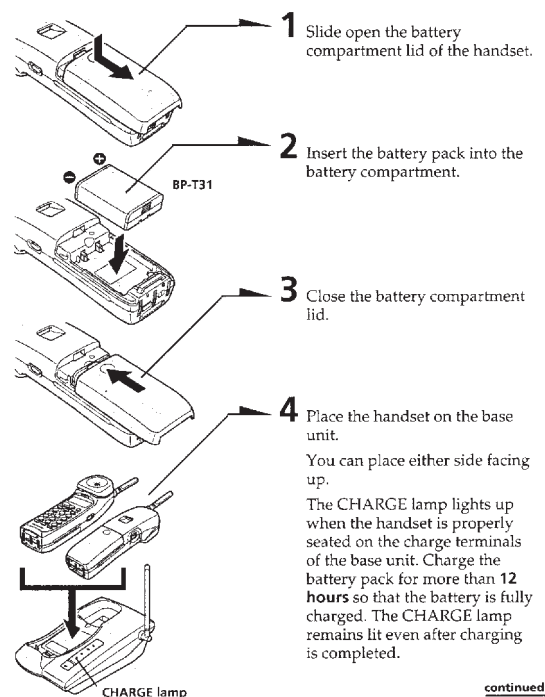

The CHARGE lamp lights up when the handset is properly seated on the charge terminals of the base unit. Charge the battery pack for more than 12 hours so that the battery is fully charged. The CHARGE lamp remains lit even after charging is completed.

continued

Step 3: Preparing the battery pack (continued)

Battery duration

A fully charged battery pack lasts for about:

- Approx. 6 hours when you use the handset continuously
- Approx. 7 days when the handset is in standby mode.

Notes

- The battery pack will gradually discharge over a long period of time, even if not in use.
- If you leave the battery pack in the handset without charging it, the battery pack will be completely discharged. It may require several times of charging to recover to its full capacity.
- While charging, the battery pack warms up. This is not a malfunction.

To obtain the best performance from the battery

Do not place the handset on the base unit after each call. The battery works best if the handset is returned to the base unit after two or three calls. However, do not leave the handset off the base unit for a long period of time as this will completely discharge the battery pack.

When to purchase a new battery pack

If the battery lasts only a few minutes even after 12 hours of charging, the usable life of the battery has expired and needs replacement. Contact your local Sony authorized dealer or service center, and ask for Sony BP-T31 rechargeable battery pack.

Note

Battery life may vary depending on usage condition and ambient temperature.

Handset spare battery usage

As only one battery pack is supplied with this unit, it is necessary to purchase an additional battery pack (optional) for use as a handset spare battery pack.

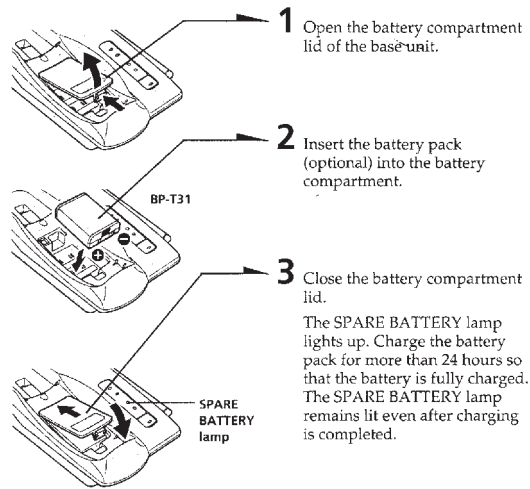

Getting Started

Step 4

Entering the area code

When you use this phone for the first time, or move to an area that has a different area code, you must enter your home area code. Otherwise, you cannot use some functions of this phone and the Caller ID functions.

This is also necessary because the phone must be able to select an area code to properly dial call from the Caller ID list.

Depending on your region, enter 3-digit area code as follows:

Case 1.

If 7-digit dialing (no area code) is accepted for local calls in your area, see "To enter your home area code" below.

If you live in an area where calls from or to other local areas can also be made by 10-digit dialing (area code + number), you can register up to 5 local area codes with this telephone to take advantage of this system. See "To enter the local area code (For 10 digits phone number users)" on page 15.

Case 2.

If 10-digit dialing (area code + number) is required for all local calls in your area, at first, enter "000" in your home area code. See "To enter your home area code" below. Then see "To enter the local area code (For 10 digits phone number users)" on page 15.

To enter your home area code

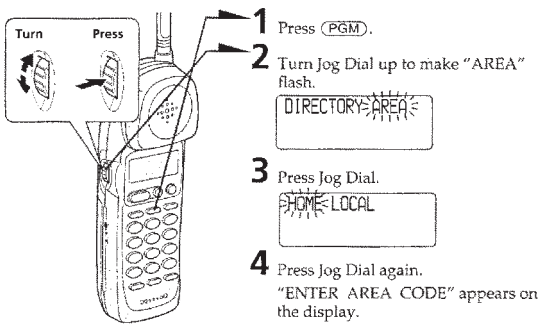

- 1 Press (PGM).
- 2 Turn Jog Dial up to make "AREA" flash.
- 3 Press Jog Dial.
- 4 Press Jog Dial again. "ENTER AREA CODE" appears on the display.
- 5 Enter three digits of your home area code using the dialing keys.
- 6 Press (PGM). You hear a long confirmation beep.

Notes

- If the home area code is already entered, it appears on the display in step 4. To enter a different home area code, see "To change the home area code" below.
- Do not allow more than 20 seconds to elapse between each step of the procedure.
- If the home area code has not been entered, calling back from the Caller ID list and storing the Caller ID data into the Phone Directory cannot be performed.

Tips

- You may press Jog Dial instead of (PGM) in step 6.
- To check the current home area code, perform steps 1 to 4. The home area code appears on the display for about 20 seconds.

To change the home area code

- 1 Perform steps 1 to 4 on page 14. The current home area code appears on the display.
- 2 Turn Jog Dial down to erase the current home area code.
- 3 Enter a new home area code using the dialing keys.
- 4 Press (PGM). You hear a long confirmation beep.

To enter the local area code (For 10 digits phone numbers users)

If a call matches one of the local area codes you entered, the phone number will be registered with 10 digits in the Caller ID list (area code + number). If a call does not match one of the local area codes you entered, the phone number will be registered with 11 digits in the Caller ID list (1 + area code + number). Some regions of the country allow you to have more than one local area code. (Up to five local area codes can be entered in this phone.)

- 1 Perform steps 1 to 3 on page 14.
- 2 Turn Jog Dial up to make "LOCAL" flash.
- 3 Press Jog Dial.

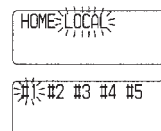

Getting Started

Step 4: Entering the area code (continued)

- 4 Select the number (“#1” to “#5”) to enter the local area code by turning Jog Dial.
- 5 Press Jog Dial.
“ENTER AREA CODE” appears on the display.
- 6 Enter three digits of the local area code using the dialing keys.
- 7 Press **PGM**.
You hear a long confirmation beep.

Notes

- If the local area code is already entered, it appears on the display in step 5. To enter a different local area code, see “To change the local area code” below.
- Do not allow more than 20 seconds to elapse between each step of the procedure.

Tips

- You may press Jog Dial instead of **PGM** in step 7.
- To check the current local area code, perform steps 1 to 5. The local area code appears on the display for about 20 seconds.

To change the local area code

- 1 Perform steps 1 to 5 on page 15.
The current local area code appears on the display.
- 2 Turn Jog Dial down to erase the current local area code.
- 3 Enter a new local area code using the dialing keys.
- 4 Press **PGM**.
You hear a long confirmation beep.

To erase the local area code

You can erase the local area code. Perform steps 1 and 2 above, then press **PGM**.
The local area code will be erased, and you hear a long confirmation beep.

Identifying the parts

Refer to the pages indicated in parentheses for details.

Base Unit

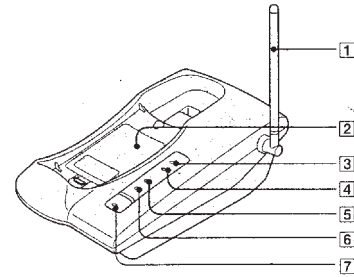

- | | |
|--|---|
| <ol style="list-style-type: none"> 1 Antenna (p. 9, 40) 2 Battery compartment (p. 13) 3 NEW CALL lamp (p. 30)
Flashes when there is a “NEW” data in the Caller ID list. 4 MESSAGES lamp (p. 38)
Flashes when you have messages. 5 SPARE BATTERY lamp (p. 13)
Lights while the spare battery is being charged. 6 CHARGE lamp (p. 11)
Lights while the battery is being charged. 7 HANDSET LOCATOR button (p. 28)
Allows you to page the cordless handset. 8 Hook for AC power adaptor cord (p. 9) | <ol style="list-style-type: none"> 9 DIAL MODE switch (p. 10)
Selects pulse or tone dialing. 10 DC IN 9V jack (p. 9, 40) 11 LINE (telephone line) jack (p. 9, 40) |
|--|---|

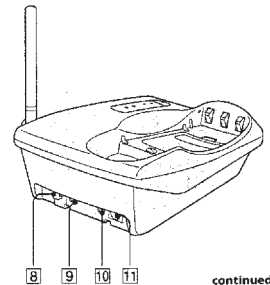

continued

Identifying the parts (continued)

Handset

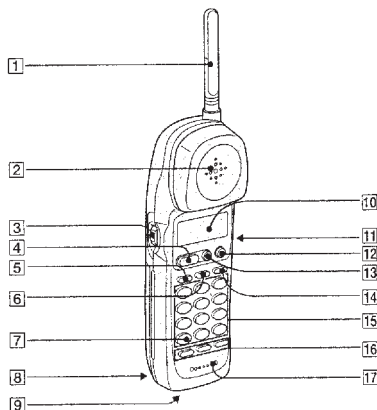

- | | |
|---|---|
| <ol style="list-style-type: none"> 1 Antenna 2 Speaker [EZfit] (p. 20) 3 Jog dial (p. 14, 24, 29) 4 TALK button (p. 19)
Lets you make or receive a call. 5 REDIAL button (p. 20)
Redials the last number called. 6 PGM (Program) button (p. 14, 22, 24)
Used to store numbers for one-touch dialing or in Phone Directory. 7 * TONE button (p. 19)
Allows you to switch temporarily to tone dialing. 8 Battery compartment (p. 11) 9 RING switch (p. 21)
Switches the ringer to on/off. | <ol style="list-style-type: none"> 10 Display window (p. 29) 11 VOL (volume) switch (p. 19)
Adjust the handset volume. 12 CALL WAITING/FLASH button (p. 21, 37)
Switches to a second call if you have “call waiting” service, or lets you make a new call. 13 OFF button (p. 19)
Allows you to disconnect the call. 14 PAUSE button (p. 23)
Inserts a pause in the dialing sequence. 15 Dialing keys (p. 19) 16 ONE-TOUCH DIAL (A, B, C) button (p. 22) 17 Microphone |
|---|---|

Basics

Making calls

- 1 Pick up the handset from the base unit.
- 2 Press **TALK** and wait until “TALK” appears on the display. The display also shows the operation duration in hours, minutes and seconds.
The dialing keys light up.
You then hear a dial tone. If you hear five short error beeps and “OUT OF RANGE” appears on the display, move closer to the base unit.
- 3 Dial the phone number.
- 4 When you’re done talking, press **OFF** or replace the handset on the base unit.
The display goes off.

Additional tasks

To	Do this
Adjust the handset volume	Set the VOL switch to H (high), M (middle) or L (low).
Switch to tone dialing temporarily	Press *TONE after you’re connected. The line will remain in tone dialing until disconnected.

Notes

- When you increase the sound volume, in some cases the background noise may be increased as well. You should adjust the volume accordingly.
- If the handset beeps every second during conversation and “OUT OF RANGE” appears on the display, move closer to the base unit; otherwise, the call will be disconnected after one minute.

continued

Making calls (continued)

EZfit

The "EZfit" adjusts to fit any shape ear, thereby ensure clear voice reception.

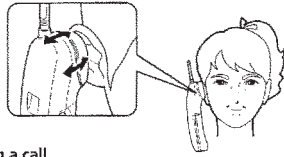

If the battery becomes weak during a call

The handset will beep twice per second, and "BATTERY LOW" appear on the display. Finish your call and charge the battery pack.

For optimum performance, charge the battery for a full 12 hours.

Note that during the initial charge time (approx. 10 minutes), and "BATTERY LOW" appear on the display and the phone cannot be used.

After and "BATTERY LOW" go off, you may be able to use the phone, but the battery duration will be very short; thus it is recommended that you fully charge the battery before next use.

Redialing

- 1 Press **TALK** and wait until "TALK" appears on the display.
- 2 Press **REDIAL** to redial the number last dialed.

Note

If the number exceeds 32 digits, five short error beeps will alert you that the number cannot be dialed.

To check the phone number before redialing

While the handset is not in use, press **REDIAL**.

The number last dialed is displayed for five seconds.

To dial the number, press **TALK** while the number is displayed.

Note

The number will not be displayed if the last dialed number exceeds 32 digits or if it is erased.

To erase the last phone number dialed

While the handset is not in use, press **REDIAL** twice.

The number will be erased from the memory, and you will hear a long confirmation beep.

Receiving calls

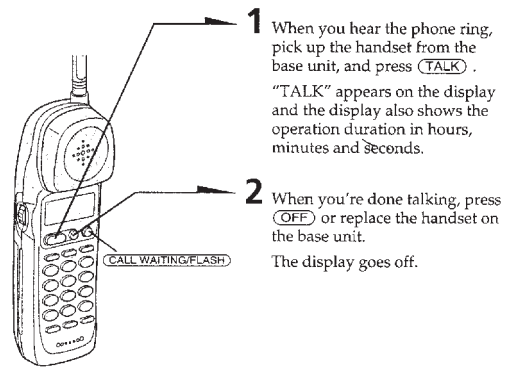

1 When you hear the phone ring, pick up the handset from the base unit, and press **TALK**. "TALK" appears on the display and the display also shows the operation duration in hours, minutes and seconds.

2 When you're done talking, press **OFF** or replace the handset on the base unit. The display goes off.

Tip

- If you have subscribed to the Caller ID service;
 - the caller's number and/or name appears on the display when you receive a call (see page 29)
 - the ringer sound changes to a higher tone if the call matches the number stored on ONE-TOUCH DIAL buttons or in the Phone Directory (memory match function; see page 29).

To switch to another call ("call waiting" service*)

Press **CALL WAITING/FLASH**.

Press the button again to get back to the first caller.

* You need to subscribe to the service from your telephone company.

To turn the ringer off

Set the RING switch on the bottom to OFF.

The handset won't ring. You can still make calls, and also receive calls if another telephone connected to the same line rings to inform you on incoming calls. You can also page the handset from the base unit.

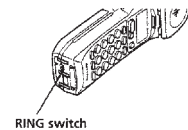

Telephone Features

One-touch dialing

You can dial with one touch of a key by storing a phone number on a one-touch dialing button.

Storing phone numbers

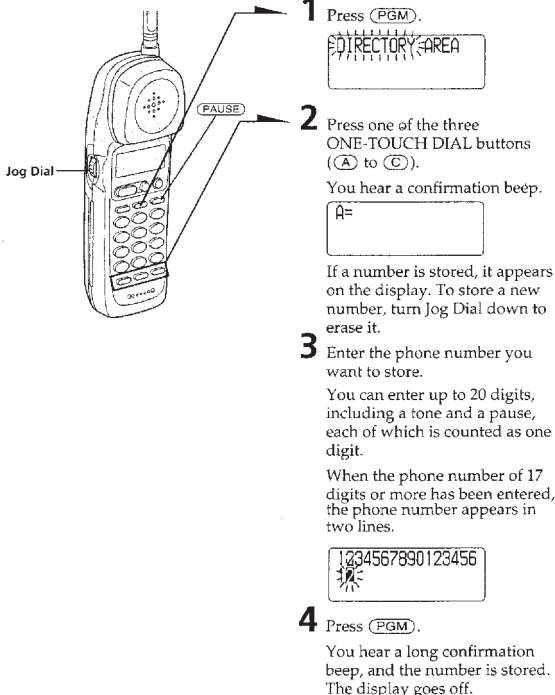

1 Press **PGM**.
 DIRECTORY AREA

2 Press one of the three ONE-TOUCH DIAL buttons (**A**) to (**C**).
 You hear a confirmation beep.
 A=

If a number is stored, it appears on the display. To store a new number, turn Jog Dial down to erase it.

3 Enter the phone number you want to store.
 You can enter up to 20 digits, including a tone and a pause, each of which is counted as one digit.

When the phone number of 17 digits or more has been entered, the phone number appears in two lines.

1234567890123456

4 Press **PGM**.
 You hear a long confirmation beep, and the number is stored. The display goes off.

Note

Do not allow more than 20 seconds to elapse between each step of the procedure.

Tips

- When the phone number of 17 digits or more has been entered, "-" is displayed next to 15th digit in step 4.
- If you have entered a wrong number in step 3 and have not pressed **PGM** (step 4) yet, just turn Jog Dial down to erase it. Then enter the correct number.
- You may press Jog Dial instead of **PGM** in step 4.

To store a number to be dialed via Private Branch Exchange (PBX)

Before entering a phone number in step 3 on page 22, do as follows:

- 1 Enter the outside line access digit (e.g., 9).
- 2 Press **PAUSE**.

To change a stored number

- 1 Press **PGM**.
- 2 Press one of the ONE-TOUCH DIAL buttons (**A**) to (**C**).
 The current number appears on the display.
- 3 Turn Jog Dial down to erase the current number.
- 4 Enter a new number.
- 5 Press **PGM**.

Note

You can replace the stored number with a new number, but you cannot just erase it.

Making calls with one-touch dialing

- 1 Press **TALK** and wait until "TALK" appears on the display.
- 2 Press one of the ONE-TOUCH DIAL buttons (**A**) to (**C**).

The phone number stored on the one-touch dialing button will appear on the display and will be dialed.

To check the phone number before one-touch dialing

While the handset is not in use, press one of the ONE-TOUCH DIAL buttons (**A**) to (**C**).

The number stored on the button appears on the display for five seconds. To dial the number, press **TALK** while the number is displayed.

Tip

When the phone number of 17 digits or more has been entered, "-" is displayed next to 15th digit and then the all digits are displayed in two lines after about two seconds.

Phone Directory

You can dial a number by scrolling through the Phone Directory.
You can store up to 100 numbers.

Storing phone numbers and names

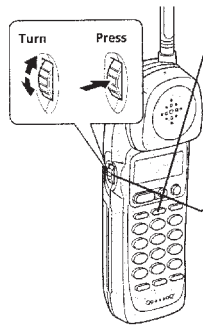

Example: to store "SONY" "123-4567".

- 1 Press **(PGM)**.
"DIRECTORY AREA" appears.
- 2 Press Jog Dial.
"ENTER NAME" appears.
- 3 Enter the name using the dialing keys.
You can enter up to 15 characters.
Press a dialing key until the desired character appears. (See the character table for details.)

Character table

Key	Character
①	1
②	A → B → C → 2
③	D → E → F → 3
④	G → H → I → 4
⑤	J → K → L → 5
⑥	M → N → O → 6
⑦	P → Q → R → S → 7
⑧	T → U → V → 8
⑨	W → X → Y → Z → 9
⑩	0
*	*
#	#

Enter successive characters in the same way.

To enter two characters assigned to the same key, or to enter a "space", turn Jog Dial up to move the cursor to the right.

Example: to enter "SONY", press **(7)** four times (S), press **(6)** three times (O), turn Jog Dial up to move the cursor, press **(6)** twice (N), and press **(3)** three times (Y).



- 4 Press **(PGM)**.
"ENTER NUMBER" appears.

- 5 Enter the phone number.
You can enter up to 20 digits, including a tone and a pause, each of which is counted as one digit.
When the phone number of 17 digits or more has been entered, the phone number appears in two lines.



- 6 Press **(PGM)**.
You hear a long confirmation beep, and the name and the number are stored. The display goes off.

Notes

- If you try to save a 101st phone number, you will hear five short error beeps and "MEMORY FULL" will be displayed. You cannot store the phone number. To store another phone number, erase one of the stored phone numbers (see page 26).
- Do not allow more than 20 seconds to elapse between each step of the procedure.

Tips

- When the phone number of 17 digits or more has been entered, "-" is displayed next to 15th digit in step 6.
- If you have entered a wrong name or number in step 3 or 5, turn Jog Dial down to erase it. Then enter the correct name or number.
- You may press Jog Dial instead of **(PGM)** in steps 4 and 6.
- To store a number to be dialed via PBX, follow the steps on page 23 when entering a phone number.

Changing a stored name and/or phone number

- 1 Display the name and phone number you want to change by doing steps 1 and 2 on page 27.



- 2 Press Jog Dial.



continued

Phone Directory (continued)

- 3 Turn Jog Dial up to make "EDIT" flash and press Jog Dial.
The cursor flashes at the last character of the name.
- 4 Turn Jog Dial down to erase the characters and enter the new name.
If you want to change only the number, skip this step.
- 5 Press Jog dial.
The cursor flashes at the last digit of the phone number.
- 6 Turn Jog Dial down to erase the number and enter the new number.
If you don't want to change the number, skip this step.
- 7 Press Jog Dial.
You hear a long confirmation beep and the name and/or the number is changed.

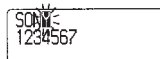

Tip

When the phone number of 17 digits or more has been entered, "-" is displayed next to 15th digit and then the all digits are displayed in two lines after about two seconds.

Erasing a memory location

- 1 Display the name and phone number you want to erase by doing steps 1 and 2 on page 27.
- 2 Press Jog Dial.
- 3 Turn Jog Dial up to make "ERASE" flash and press Jog Dial.
- 4 Turn Jog Dial up to make "YES" flash, then press Jog Dial.
You hear a long confirmation beep and the memory location is erased.

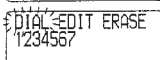
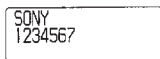

Making calls from the Phone Directory

- 1 Press Jog Dial.
"DIRECTORY" appears on the display.
- 2 Display the name and phone number you want to call.
To search in alphabetical order: Turn Jog Dial up or down.
To search by entering the initial character: Press the dialing key of the desired character, then turn Jog Dial.
- 3 Press Jog Dial.
"DIAL EDIT ERASE 1234567" appears.
- 4 Press Jog Dial again.
The phone number will be dialed.

Tips

- You may press **(TALK)** to make a call instead of doing steps 3 and 4.
- When the phone number of 17 digits or more has been entered, "-" is displayed next to 15th digit and then the all digits are displayed in two lines after about two seconds.

About the search order

The names appear in the following order when you turn Jog Dial up or down.

- Alphabetical order: ABC...XYZ ↔ symbols ↔ * ↔ # ↔ 0-9

- Initial character: To search for "SONY" for example, press **(7)** and then turn Jog Dial to search through the names starting with P, Q, R, S or T.

Paging

You can page the handset from the base unit.
Note that you cannot page if the handset is in use.

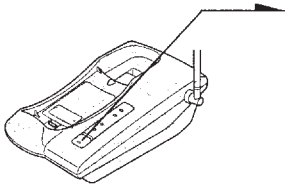

To Page

Press **(HANDSET LOCATOR)**.
The handset rings for about one minute.
To stop ringing, press **(TALK)** or **(OFF)** on the handset.

Tip
You can page the handset even when its RING switch is set to OFF.

Caller ID Features

Understanding the Caller ID service

Caller ID allows the caller's phone number to be shown on the display before you answer the call. In order to use this feature, you must first subscribe to Caller ID service. The name of this service may vary depending on your telephone company.

To use this feature, be sure to enter your home area code (see page 14).

When you receive a call

The phone number appears on the display with the date and time as shown in the following example.

If your Caller ID service includes the caller name service, the caller's name also appears on the display (up to 15 letters).

Caller's name	SMITH JOHN
Caller's phone number	1-201-123-4567
The date and time received	7.04pm 4:53

When you answer the call, the Caller ID display changes to the "TALK" display.

Notes

- The caller's phone number and/or name will not appear in the following cases:
 - "OUT OF AREA": when the call is made through a telephone company which does not offer Caller ID service (including international calls).
 - "PRIVATE": when the call is "blocked". For privacy reasons, many states allow callers the option to prevent his or her telephone data from being displayed on the other party's Caller ID display.
 - If the call is from an office which uses multiple lines, the displayed phone number may not match the number you use to call the extension.

Tip

Even if the RING switch is set to OFF, you can receive Caller ID data.

About the memory match function

If you receive a call from a phone number which is stored on one of the ONE-TOUCH DIAL buttons (see page 22) or in the Phone Directory (see page 24), the ringer sound will change to a higher tone from the second ring.

Note

The memory match function does not work with "OUT OF AREA" or "PRIVATE" calls; and it may not work with calls made from an office which uses multiple lines because the number does not always match the one you stored in this phone.

Looking at the Caller ID list

The phone stores the data of the last 20 calls received including "OUT OF AREA" and "PRIVATE" calls. It keeps track of all calls received; even if they were not answered.

Viewing the Caller ID list

You can look through the Caller ID list to check the phone number and/or name of the calls received.

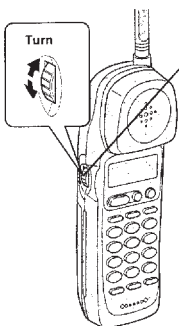

- Turn Jog Dial.
The display shows the number of "NEW" (calls which you have not viewed) and "OLD" (calls which you have viewed) calls.
- Turn Jog dial down to display older data or up to display newer data.

Notes

- If a 21st call is received, the oldest data is automatically erased.
- When you have checked all data, "END OF LIST" appears.

Tip
If there is a "NEW" data, the NEW CALL lamp of the base unit flashes.

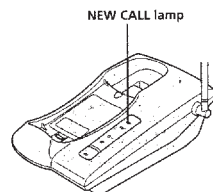

About the "*" mark

SMITH JOHN	*
1-201-123-4567	
NEW 08 7.04pm 4:53	

"*" appears if there are more than two calls from the same phone number. The older data will be replaced by the new data, so the calls are counted as only one call.

Erasing data from the Caller ID list

Old data will be erased automatically when a 21st call comes in, but you can also manually erase unnecessary data one by one or erase the entire list.

To erase the phone number one by one

- Display the phone number you want to erase from the Caller ID list (see page 30).
- Press Jog Dial.
- Turn Jog Dial up to make "ERASE" flash and press Jog Dial.
- Turn Jog Dial up to make "YES" flash, then press Jog Dial.
You hear a long confirmation beep and the data is erased.

continued

Looking at the Caller ID list (continued)

To erase the entire list at once

- 1 Display any Caller ID data.

SMITH JOHN
1-201-123-4567
NEW 08 7:04 PM 4:53

- 2 Press Jog Dial.

DIAL PGM ERASE
1-201-123-4567
NEW 08 7:04 PM 4:53

- 3 Turn Jog Dial up to make "ERASE" flash and press Jog Dial.

ERASE NO YES ALL
1-201-123-4567
NEW 08 7:04 PM 4:53

- 4 Turn Jog Dial up to make "ALL" flash, then press Jog Dial.

ALL ERASE NO YES
1-201-123-4567
NEW 08 7:04 PM 4:53

- 5 Turn Jog Dial up to make "YES" flash, then press Jog Dial.

NEW 08 08 00

You hear a long confirmation beep and the entire list is erased.

Note

"ALL" appears only when all the data had become "OLD" data. If there is any "NEW" data, you cannot erase the entire list.

Using the Caller ID list

By using the Caller ID list, you can call back a phone number from the Caller ID list easily, or store numbers from the Caller ID list into the Phone Directory.

Calling back a number from the Caller ID list

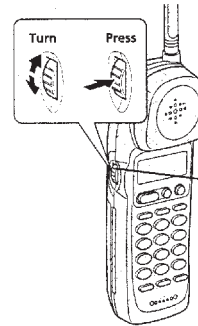

- 1 Display the phone number you want to call from the Caller ID list (see page 30).

SMITH JOHN
1-201-123-4567
NEW 08 7:04 PM 4:53

- 2 Press Jog Dial.

DIAL PGM ERASE
1-201-123-4567
NEW 08 7:04 PM 4:53

- 3 Press Jog Dial again.

The phone automatically dials the displayed number.

Notes

- If the number displayed in step 1 is not the one you should call back, you can change the number of digits of the phone number as described on page 35.
- If the phone is connected to a Private Branch Exchange (PBX), you may not be able to call back from the Caller ID list because an outside line access digit is necessary.

Tip

You may press **(TALK)** to make a call instead of doing steps 2 and 3.

Using the Caller ID list (continued)

Storing a number of the Caller ID list into the Phone Directory

- 1 Display the name and phone number you want to store from the Caller ID list (see page 30).

SMITH JOHN
1-201-123-4567
NEW 08 7:04 PM 4:53

- 2 Confirm the number and press Jog Dial.

DIAL PGM ERASE
1-201-123-4567
NEW 08 7:04 PM 4:53

- 3 Turn Jog Dial up to make "PGM" flash and press Jog Dial.

SMITH JOHN
12011234567

The cursor flashes at the end of the name.

Enter or change the name, if necessary (see page 25).

- 4 Press Jog Dial.

The cursor flashes at the end of the phone number.

Enter or change the phone number, if necessary (see page 25).

- 5 Press Jog Dial again.

You hear a long confirmation beep and the name and number are stored.

Notes

- Do not allow more than 20 seconds to elapse between each step of the procedure.
- If the number displayed in step 1 is not the one you should call back, you can change the number of digits of the phone number as described on page 35.
- If the phone is connected to a Private Branch Exchange (PBX), you may need to add an outside line access digit.

To change the number of digits of the phone number

If the number of digits of the phone number in the Caller ID list is different from the actual phone number, you need to adjust the number of digits of the phone number to call back or store into the Phone Directory.

- 1 While the phone number from the Caller ID list is displayed, press **(#)** repeatedly until the phone number with the correct number of digits appears on the display. Each time you press **(#)**, the number of digits changes as follows.

When the home area code and the local area code do not match

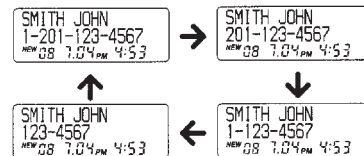

When the home area code matches

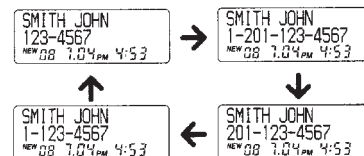

Using the Caller ID list (continued)

When the local area code matches

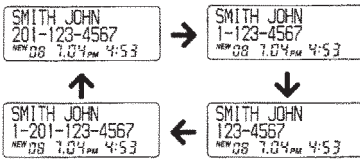

- Continue the operation to call or store the phone number with the correct number of digits (pages 33 and 34).

Notes

- You need to adjust the number of digits each time you call back from the Caller ID list as the changes to the Caller ID data is not stored in memory.
- You may not be able to change the number of digits depending on the Caller ID data.

Using "Caller ID with call waiting" service

This telephone is compatible with the "Caller ID with call waiting" service. Make sure that your telephone company offers this service.

Like the basic Caller ID service, you need to subscribe to "Caller ID with call waiting" in order to use this service.

Even though you may have already subscribed to "Caller ID" and "call waiting" as two separate services, you need to request a subscription to "Caller ID with call waiting" as a single service.

This is a new service that combines the two services.

Even though you now have a "Caller ID with call waiting" compatible phone, unless you subscribe to the combined "Caller ID with call waiting" service, you will not be able to see the name and number of the second caller.

When a new call comes in while you are talking, the caller's name and/or phone number of the new call appears on the display for about 20 seconds.

To switch to another caller

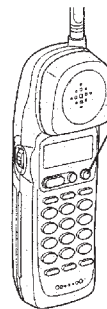

- To switch to the new caller, press **(CALL WAITING/FLASH)**.
- To switch back to the first caller, press **(CALL WAITING/FLASH)** again.

Using visual message waiting service

If you subscribe to your telephone company's message service which includes this feature, the display will show that you have messages waiting to be retrieved.

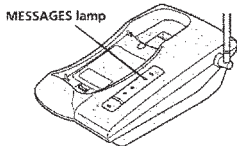

If you have messages

When the handset is placed on the base unit, the MESSAGES lamp on the base unit flashes.

When the handset is not placed on the base unit, "MESSAGES WAITING" will appear every five seconds on the display, and the MESSAGES lamp on the base unit flashes.

The display and the MESSAGES lamp will go off when you retrieve your messages.

Note

You cannot use this feature, if you have not subscribed to your telephone company's message service. For details on the availability of this service, please ask your telephone company.

If the MESSAGES lamp remains flashing

If this lamp does not go off (e.g. When you retrieve your messages with other phones), you can go off the lamp manually.

To go off the MESSAGES lamp

- Press **(PGM)**.
- Press **(#)**.
- Press Jog Dial.

The MESSAGES lamp on the base unit goes off, and you hear a long confirmation beep.



If you move or change your telephone company

Message waiting signals are sent in one of two ways: FSK signaling or "stutter" signaling (Your telephone company can provide you with more information about your service).

The first time this phone receives a voice mail message, it will set itself to the FSK service and will lock out the stutter service if your telephone company is in FSK service.

When you move or change your telephone company, you need to reset this phone. To reset, perform the following procedure. The phone will return to ready state for either FSK or stutter dial tone voice mail recognition.

To reset this phone

- Press **(PGM)**.
- Press **(#)**.
- Turn Jog Dial up to make "RESET" flash and press Jog Dial.
You hear a long confirmation beep and the phone is reset.



Mounting the base unit on a wall

- 

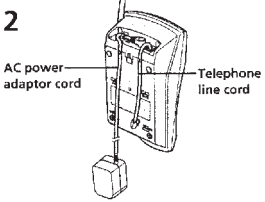
1 Raise the hang up tab.
- 

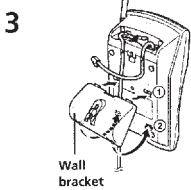
2 Plug the telephone line cord to the LINE jack and the AC power adaptor to the DC IN 9V jack, and hook the cords. Use the shorter cord for mounting.
- 

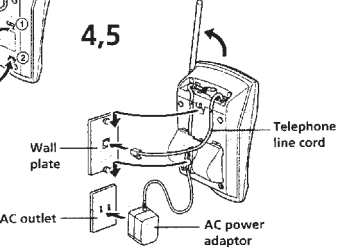
3 Attach the wall bracket to the center of the base unit. Align the Δ marks of the wall bracket with those of the base unit.
- 

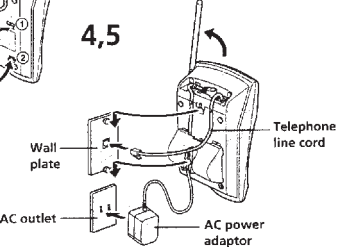
4 Plug the telephone line cord to the telephone outlet, and hook the base unit to the wall plate.
- 

5 Plug the AC power adaptor to an AC outlet. Then raise the antenna so that it points towards the ceiling.

Tip
To remove the wall bracket, press the lower tabs.

SECTION 2 DISASSEMBLY

Note: Follow the disassembly procedure in the numerical order given.

2-1. BATTERY CASE LID (HANDSET)

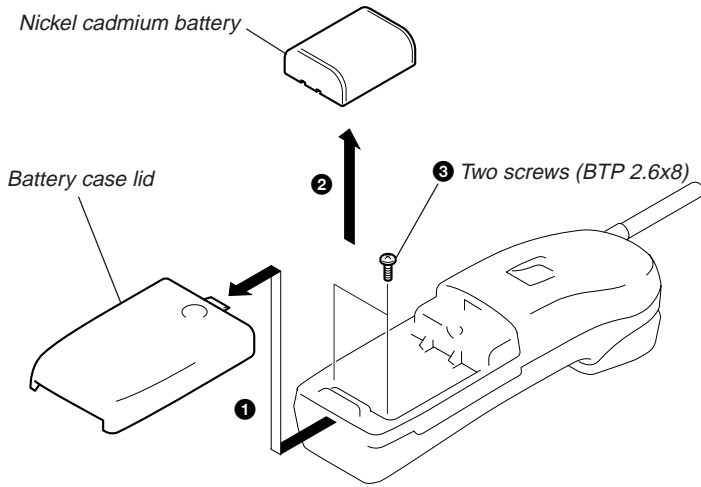

2-2. CABINET (REAR)(HANDSET)

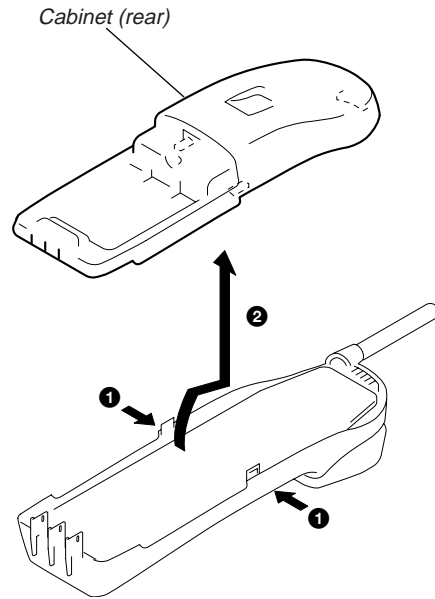

2-3. HAND MAIN BOARD (HANDSET)

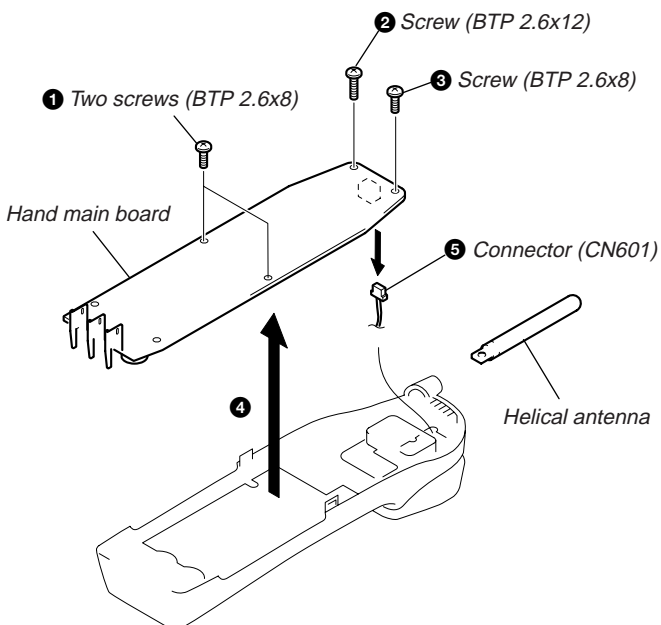

2-4. CABINET AND BOARDS (BASE UNIT)

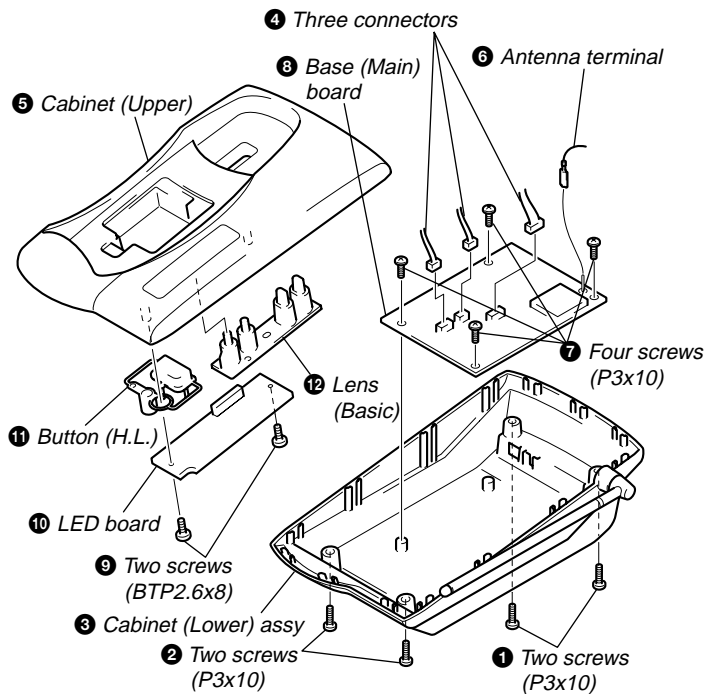

SECTION 3

900 MHz SYSTEM OPERATION

3-1. ACCESS METHOD

1. Transfer Format & Rate

The transfer format & rate of our system is as follows;

Table 3-1. Transfer method

Access method	FDMA-TDD
Channel number	14 channel
Channel spacing	1.2 MHz
Modulation method	DBPSK
Baseband transfer rate	960 Kbps
Spread method	Direct Sequence Spread Spectrum
Chip rate	12 chips/bit
Data transfer rate	80 Kbps

2. Channel Number & Frequencies

RF channels occupy the frequency band 902 – 928 MHz are numbered 1 to 14.

RF channel numbers & center frequencies are specified as follows.

Table 3-2. Channel number & Channel frequency

Channel Number	Channel Center Frequency (MHz)	
	UNIT CH PLAN	TEST MODE CH PLAN
1	907.2	904.2
2	908.4	904.8
3	909.6	906.0
4	910.8	907.2
5	912.0	908.4
6	913.2	909.6
7	914.4	910.8
8	915.6	912.0
9	916.8	913.2
10	918.0	914.4
11	919.2	915.6
12	920.4	916.8
13	921.6	918.0
14	922.8	919.2
15		920.4
16		921.6
17		922.8
18		924.0
19		925.2
20		925.8

***Note)** The UNIT has 14 channels according to the UNIT CH PLAN while the number of channels which can be used in the test mode are those in the TEST MODE CH PLAN.

3-2. PROTOCOL

1. General

This system realizes the TX/RX superframe by TDD system. The relation of master/slave does not decide identification regarding the protocol between BASE UNIT and HANDSET, but the initiated side is the master and the requested side is the slave when the RF link has been established.

2. Initial Acquisition

In order to establish the RF link between BASE UNIT and HANDSET, both of BASE UNIT and HANDSET need to have the same system ID. When “power” is applied to this system, the system have to do Initial Acquisition in order to have the same system ID. It is to exchange a parameter when the HANDSET is parked on the BASE UNIT, as soon as the system do System Parameters Re-initialization.

3. System Parameter Re-initialization

This System Parameters Re-initialization can realize that the HANDSET is parked on the BASE UNIT. So after the BASE UNIT recognized to be parked the HANDSET, the BASE UNIT calculates a system parameter, and then it outputs this data from the ARTO port, and then the system establishes the RF link. In order to establish this link, the HANDSET send the A-Frame to the BASE UNIT after the HANDSET received the system parameter, and then the BASE UNIT send the A-Frame to the HANDSET. The process of System Parameters Re-initialization is as follows.

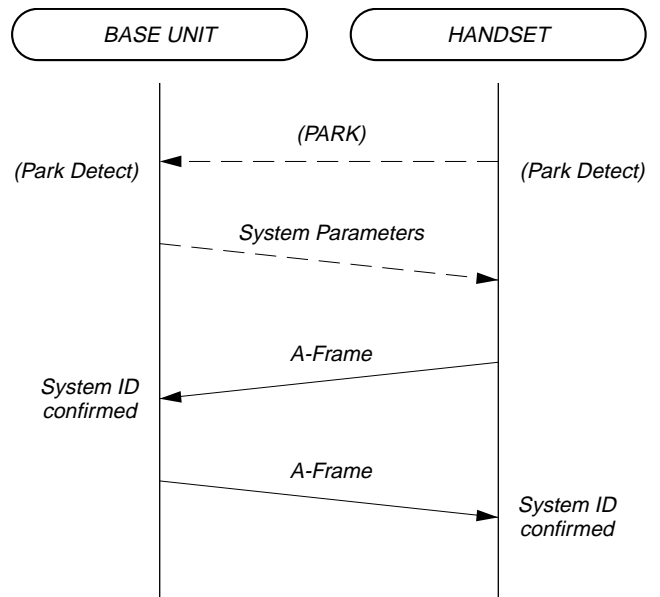

Fig. 3-1. System Parameters Re-initialization

4. Stand-by Mode Operation

(1) HANDSET

When the HANDSET is the stand-by mode (sleep mode), the HANDSET do the intermittent operation for power save, because the HANDSET is the battery operation.

This process of stand-by mode operation is as follows.

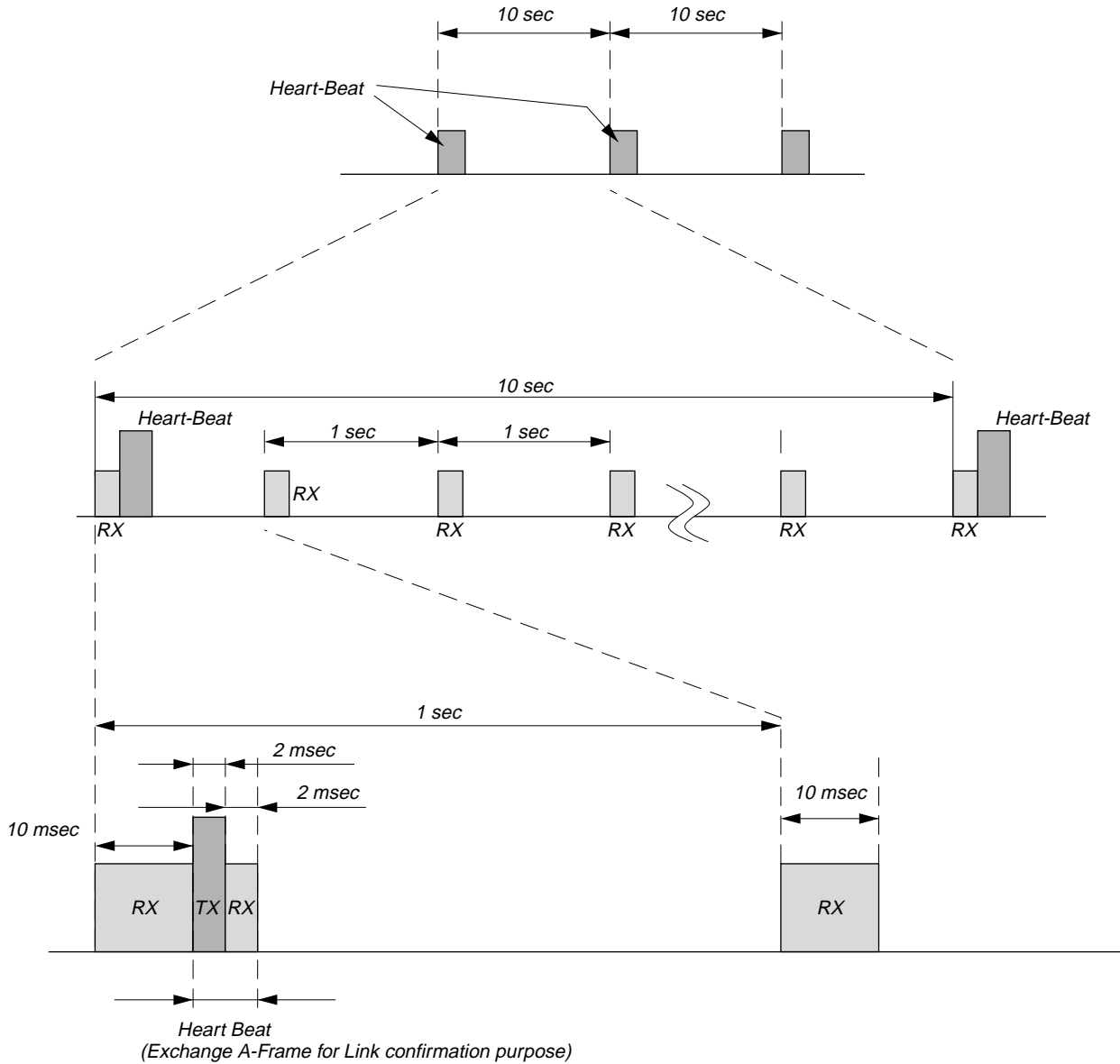

Fig. 3-2. Stand-by mode operation (HANDSET)

(2) BASE UNIT

The BASE UNIT is supplied the power by AC line. While the BASE UNIT is the stand-by, the BASE UNIT is always a wake state. While the BASE UNIT monitors the current channel, the BASE UNIT monitors also the other channel at the same time

Because if the current channel can not use by some interference, the system needs the clear channel information as a part of system parameter for a channel hop.

If the BASE UNIT can not receive the A-Frame of Heart-beat from the HANDSET, it become "link error", and the system become error recovery mode.

5. Link Establishment

According to the following Fig. 3-1, the requested side for link establishment is the master.

The system have to exchange the A-Frame for link establishment, and each system ID should be the same ID, and then the system link is established.

The protocol and timing chart of link establishment are as follows.

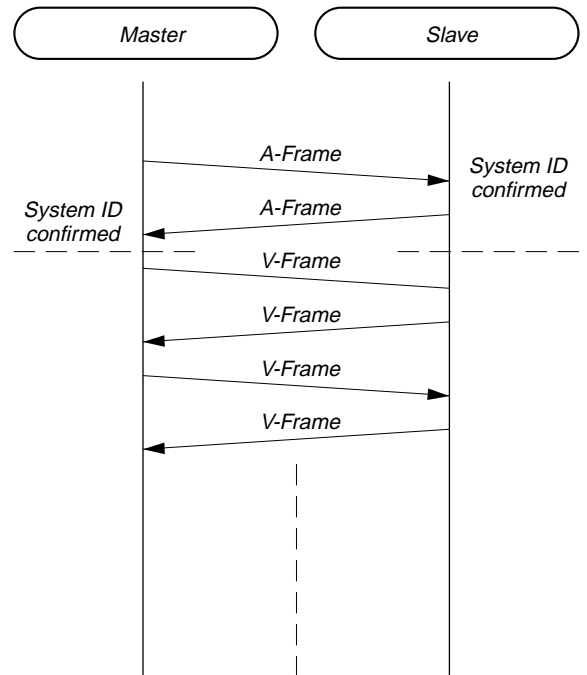

Fig. 3-3. Link Establishment protocol

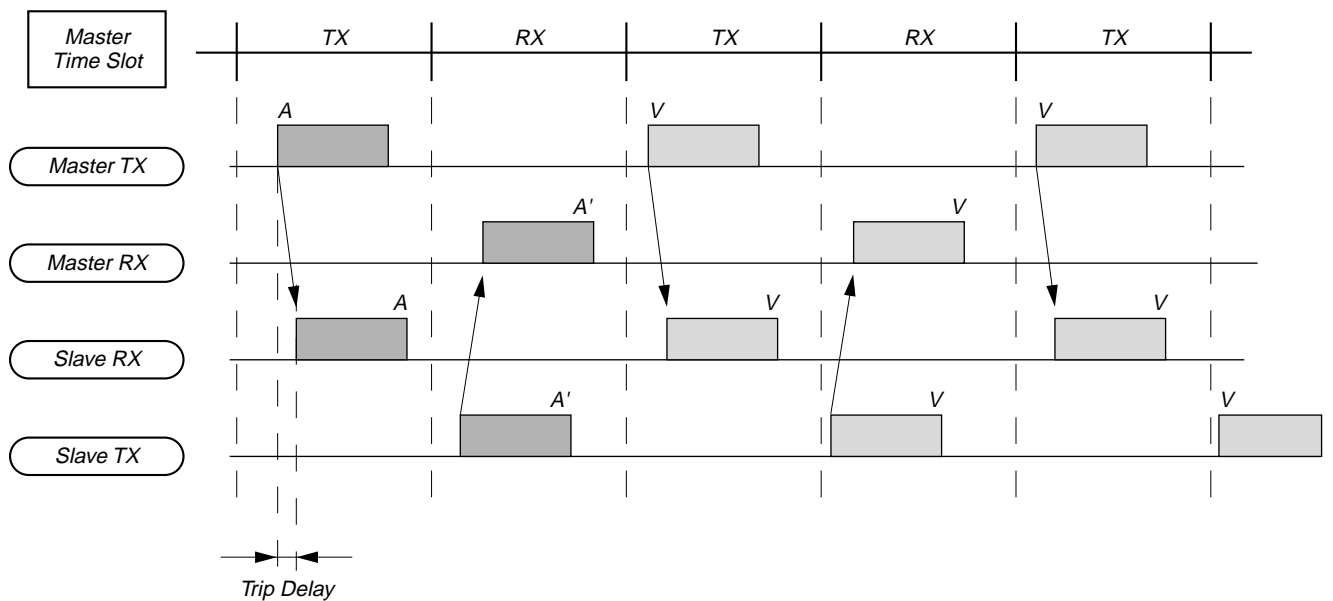

Fig. 3-4. Link Establishment Timing Chart

6. State Change/Tarmination

After the RF link between HANDSET and BASE UNIT was established, a movement of each state (State: ON-Hook, OFF-Hook, PAGE, InterCom, etc) is sent through supervisory bits.

7. Error Recovery

In case of the following situation, The system becomes "Error Recovery Mode".

- (1) The system failed to move to "Heart-Beat" during "Stand-by mode, or failed "link establishment".
- (2) The system failed to keep the link.

SECTION 4 TEST MODE

4-1. BASE UNIT TEST MODE A

Manual System Test Mode

[Start-up]

1. Set the **[DIAL MODE]** switch to P (PULSE), and turn on the power while pressing the **[HANDSET LOCATOR]** key.
2. Change the **[DIAL MODE]** switch from P (PULSE) to T (TONE) → P (PULSE), and release the **[HANDSET LOCATOR]** key to start up.
3. After starting up Test Mode A, perform dial test.
4. The TEST MODE A state will be set after the dial test.
5. In test mode idling A, pressing the **[HANDSET LOCATOR]** key with the P (PULSE)/T (TONE) switch set to P (PULSE) state switches to BASE UNIT TEST MODE A-1.

[DIAL MODE] switch	Idle status
P (PULSE) side	Test Mode Idle A-1
T (TONE) side	Test Mode Idle A-2

[Dial Test]

After starting BASE UNIT TEST Mode A, close the circuit for about 500 msec after start, and dial **[PAUSE]**, **[0]** (DP), wait 2 seconds, **[1]** (Tone), **[4]** (Tone), **[8]** (Tone), **[#]** (Tone) in this order.

[Ring Detect Test]

1. Rings the Normal Ringer synchronized with an external call coming in, and blinks the IC501 Pin ⑫, ⑬ (New Call LED/MES-SAGE LED) at the same time.

[CID Type 1 Reception Test]

1. When an external call comes in, receive the CID Type 1 signal (the CID signal timing conforms to the regular specifications). If it could be received correctly (determined by whether the checksum is correct), the New Call LED is blinked, and hereafter the ringer sounds and lights up the memory match tone.

[Visual Message Waiting Indicator Test]

1. During test mode idling, receive the signal (the CID signal timing conforms to the regular specifications) of the Visual Message Waiting Indicator generated by the PJK signal. If it could be received correctly, (determined by whether the checksum is correct), the New Call LED is lit. At the same time, the MESSAGE LED is synchronized and blinked.

[Charge Detection and ART0 Output Test]

1. Detects that the charge detection terminal IC501 Pin ⑳ (PARKP) has turned from H to L, and outputs a square waveform signal (2.4 kbps) from the ART0 terminal.
2. Clears the EEPROM contents at the same time.

[Charge Control Test]

1. When the IC501 Pin ⑲ input (BATT_CHK) changes from L, H, to L during charge detection, the IC501 Pin ⑰ output (CHRG_CTL) will output L, H, LH, L, to H only once.

[Branch Detection Test]

When the shared phone is detected to be off the hook and the Branch detection terminal IC501 Pin ㉑ (EXT_DET) detects L, the MESSAGE LED is lit. When off-hook is detected and the Branch detection terminal IC501 Pin ㉑ (EXT_DET) detects H, the MESSAGE LED is turned off.

4-1-1. BASE UNIT Test Mode A-1

1. In test mode idling A and the P (PULSE)/ T (TONE) switch set to the P (PULSE) state, pressing the **[HANDSET LOCATOR]** key changes the mode as shown below.
 2. Setting the P (PULSE)/ T (TONE) switch from P (PULSE) to T (TONE) in the BASE UNIT test mode A-1 in any time also enables the mode to be changed to the BASE UNIT test mode idling A.
- This mode is intended for checking that the IC501 line is operating properly. Add the LINEIN signal and check that the signal is output to the SPEAKER OUT.

[HANDSET LOCATOR] button pressing count	Test mode
1	CODEC Forward Loopback (L1) (Line: Talking state) (CODEC LINE IN → SPEAKER OUT)
2	ADPCM Forward Loopback (L2) (Line: Talking state) (CODEC LINEIN → ADPCM → CODEC SPERKER OUT)
3	Does not function
4	Returns to BASE UNIT TEST MODE • IDLING A

Note: If the LEDs are lit due to the idling state test, clear all the LEDs, and return to the idling state.

[Base Set AUDIO Input/Output Level test [CODEC Forward Loop Back (L1) Mode]]

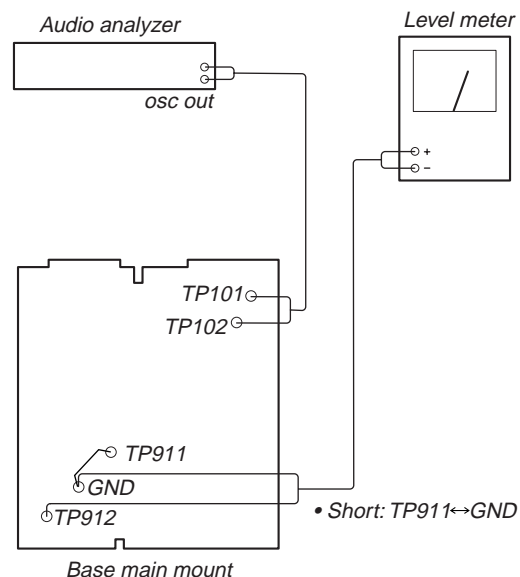

Setting:

Setting: OSC=-13.0 dBV (Open terminal)
MOD=1 kHz

4-2. BASE UNIT TEST MODE B

Manual System Test Mode

[Start-up]

1. Set the **DIAL MODE** switch to T (TONE), and turn on the power while pressing the **HANDSET LOCATOR** key.
2. Change the **DIAL MODE** switch from T (TONE) to P (PULSE) → T (TONE), and release the **HANDSET LOCATOR** key to start up.
3. The TEST MODE B state will be set.
4. In test mode idling B, pressing the **HANDSET LOCATOR** key with the P (PULSE)/T (TONE) switch set to T (TONE) state switches to BASE UNIT TEST MODE B-1.

DIAL MODE switch	Idle status
T (TONE) side	Test Mode Idle B-1 *1
P (PULSE) side	Test Mode Idle B-2 *2

*1 Radio block: TDD mode (master timing)

Audio block: Line speech status

*2 Radio block: Standby status

Audio block: Line open

[Call Waiting Reception Test]

1. Set the audio signal route to the normal TALK state, and receive the Caller ID Type 2 data (the CID signal timing conforms to the regular specifications). If it could be received correctly, (determined by whether the checksum is correct), the New Call LED is lit. At the same time, the VMWI LED is synchronized and blinked.”

[Stutter Tone Detection]

1. Monitors the stutter tone detection terminal IC501 pin ⑨ (Detect_In) at all times and lights the VMWI LED when 5 pulses are detected like in actual operations.

4-2-1. BASE UNIT Test Mode B-1

1. In test mode idling B with the P (PULSE)/T (TONE) switch set to the T (TONE) state, pressing the **HANDSET LOCATOR** key changes the mode as shown below.
2. Setting the P (PULSE)/T (TONE) switch from T (TONE) to P (PULSE) in BASE UNIT test mode B-1 any time also enables the mode to be changed to BASE UNIT test mode idling B.

HANDSET LOCATOR button pressing count	Radio mode
1	1ch single carrier continuous transmission mode (high power)
2	10ch single carrier continuous transmission mode (high power)
3	20ch single carrier continuous transmission mode (high power)
4	1ch continuous transmission mode (high power)
5	1ch continuous transmission mode (middle power)
6	1ch continuous transmission mode (low power)
7	10ch continuous transmission mode (high power)
8	10ch continuous transmission mode (middle power)
9	10ch continuous transmission mode (low power)
10	20ch continuous transmission mode (high power)
11	20ch continuous transmission mode (middle power)
12	20ch continuous transmission mode (low power)
13	1ch continuous reception mode
14	10ch continuous reception mode
15	20ch continuous reception mode
16	Returns to BASE UNIT TEST MODE • IDLING B

Note: If the LEDs are lit due to the idling state test, clear all the LEDs, and return to the idling state.

4-2-2. Ending the Base Unit Test Mode

1. To end the base unit test mode, turn off the power of the base unit.

[BASE UNIT carrier frequency measurement [Single carrier 1CH continuous transmission]]

Setting:

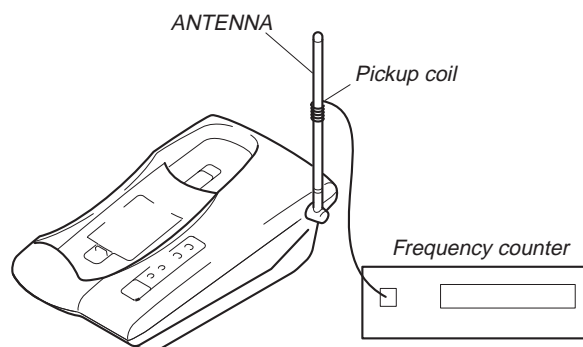

Spec: 904.2 MHz ± 27KHz

4-3. HANDSET TEST MODE

[Start-Up]

1. Press the **TALK**, **0**, and **1** keys simultaneously to start.
2. The normal ringer is rung at a high level for 500 msec after starting, and the TALK LED and BATT LOW LED blink together. The HANDSET TEST MODE and idling state LEDs will remain lit.
3. The unit sets into the test command key input standby state. The state can be changed to a desired test mode item by pressing a command key.
4. In the HANDSET TEST MODE idling state, all LEDs are turned ON (the state where the LCD backlight lights up).

[Battery Low Detection Test]

1. In the HANDSET TEST MODE idling state, if Low Battery is detected (if the battery input terminal (IC401 Pin ⑦) is grounded), the TALK (Basic) LED goes off. A confirmation beep which lights up the BATT LOW LED sounds.
2. If the Low Battery state is cleared (if the battery input terminal (IC401 Pin ⑦) is released its grounding), the TALK (Basic) LED is lit. The BATT LOW LED goes off and the previous HANDSET TEST MODE idling state is returned.
3. The mode cannot be changed to other HANDSET TEST MODE with Low Battery detected (Battery input terminal (IC401 Pin ⑦) is grounded).

[Setting the Handset Test Mode by Test Command Key Inputs]

By entering test commands from the keypad in the HANDSET TEST MODE, the following test items can be set.

- However, to set a test with a different test group, be sure to return to test mode first and then set the desired mode.

A) Test Resetting

Command	Mode/Operation
0-0-#	Ends the test mode. Clears the EEPROM data. Sounds the ACK beep if OK. Exits the test mode and returns to the normal operating state.
0-1-#	Returns to test mode idling.

B) Continuous Reception Test

Command	Mode/Operation
1-1-#	1ch continuous reception (LNA, AGC ON)
*	CH increment. 1ch → 2ch → 3ch → 4ch → → 20ch

Note: In the continuous reception test, the "All 1's Data" in ASIC should be used.

C) Continuous Transmission Test

Command	Mode/Operation
2-1-#	1ch continuous transmission (TX power High)
2-2-#	1ch continuous transmission (TX power Mid)
2-3-#	1ch continuous transmission (TX power Low)
2-4-#	Single carrier 1ch continuous transmission (TX power High)
*	CH increment 1ch → 2ch → 3ch → 4ch → → 20ch

Note: In the continuous reception test, the "All 1's Data" in ASIC should be used.

[Handset AUDIO Input/Output Level Measurement [CODEC Forward Loopback (L1); 2-4-#]]

Setting:

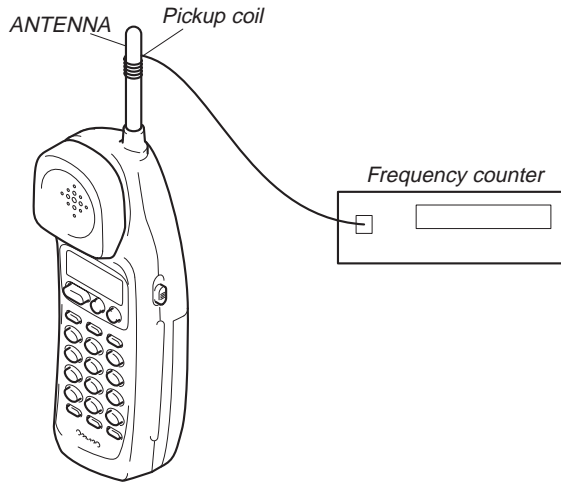

Spec: 904.2 MHz ± 27KHz

D) Loopback Test

Command	Mode/Operation
3-1-#	CODEC Forward Loopback (L1) (MIC → SP) (within CODEC)
3-2-#	ADPCM Forward Loopback (L2) (MIC → CODEC → ADPCM → CODEC → SP)
3-3-#	Does not function.

Note: In the loopback test, the sound route of the handset is set to the normal TALK state (Set Mic-in and SPKO to be effective).

[Handset AUDIO Input/Output Level Measurement [CODEC Forward Loopback (L1); 3-1-#]]

Setting:

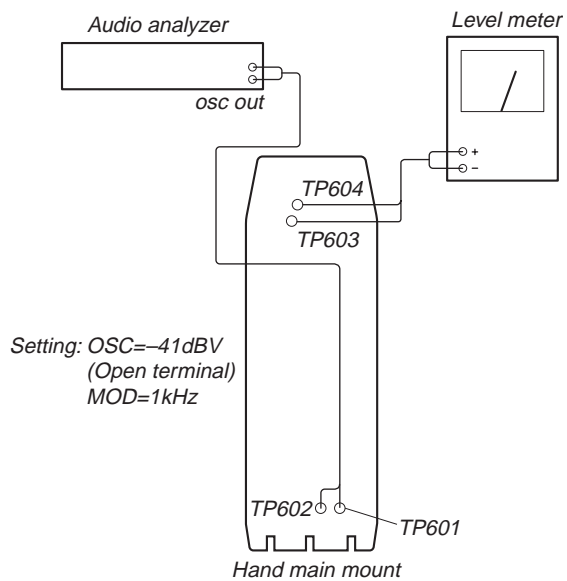

Setting: OSC=-41dBV
(Open terminal)
MOD=1kHz

Spec: -27.5 to -23.5 dBV

E) MMI Test

Command	Mode/Operation
5-1-#	Key matrix test
5-2-#	JOG shuttle test
5-3-#	LCD test
5-4-#	LED OFF 1) Press the One-Touch B key and turn off the LCD Backlight LED. (CID/LCD) 2) Press the One-Touch B key and turn off the DIAL LED. (CID/LCD) 3) Press the One-Touch B key and turn on all LEDs and return to step 1. (CID/LCD)

Details

1. Key Matrix Test: 5-1-#

If the keys are pressed continuously in the following designated order correctly, a confirmation beep sounds. If pressed incorrectly, an error beep sounds and the unit returns to the idling state.

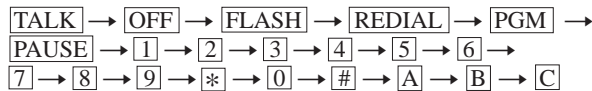

2. JOG shuttle test: 5-2-#

- When the JOG shuttle is rotated in the clockwise direction, R is displayed on the LCD. When rotated in the counterclockwise direction, L is displayed. When the JOG shuttle is pressed, P is displayed. (1st line and digit of the LCD)."

3. LCD test mode: 5-3-#

- Set the mode which lights up all dots.

F) Others

Command	Mode/Operation
7-0-#	Clears all EEPROM data.
7-1-#	Clears EEPROM ID data. If cleared successfully, sounds the ACK beep.
9-0-#	Battery Save Mode

4-3-1. Ending the HANDSET Test Mode

- Entering the command "0-0-#" from the keypad in any state of the HANDSET TEST MODE ends the HANDSET MODE and returns the normal mode.

4-4. RF TESTING

This test is for checking the RF system without disassembling the set in servicing. Perform measurement using the spectrum analyzer and jig antenna.

4-4-1. RF Testing method

Please follow the below instruction to perform RF test.

[Setting Condition]

Connect a receiving antenna to RF INPUT of Spectrum analyzer and set the unit 10 cm (4 inches) away from the receiving antenna.

Measuring tool: Spectrum analyzer (equivalent to HP8595E)

Jig: Receiving antenna (for Spectrum analyzer)

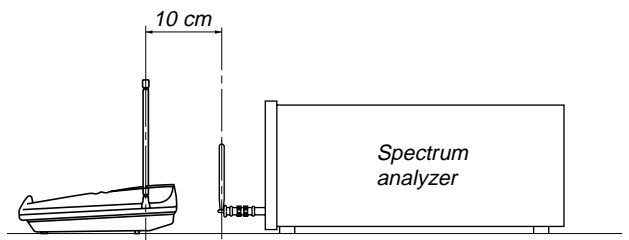
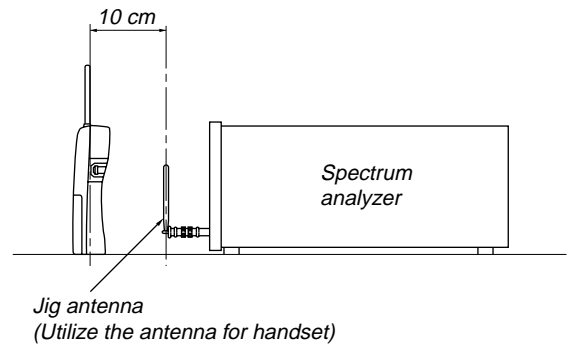

[Check the Transmission Wave]

Purpose

It is necessary to check spectrum wave of transmission wave which is an important factor in order to confirm operational performance of Spread Spectrum models. If this wave deviates from correct wave form, normal data transmission cannot be made and, as a result of that, possibility that occurrence of mute increases and communication distance becomes shorter will increase.

Measuring process

- Setting Spectrum analyzer:
 - Center frequency : 904.2 kHz (CH1)
 - RBW : 30 kHz
 - VBW : 30 kHz
 - Span : 3 MHz (or 5MHz)
- Setting Test mode:
 - Continuous Transmit mode (CH1 High Power)
 - (Refer to "Test Mode" on page 10)
- Measurement:
 - Measure transmitting wave.
- Specifications:
 - Acceptable level [XdB] difference between the highest peak and the lowest peak of odd side band (the first to seventh side band from Center Frequency ; Transmission Frequency f₀: CH1) is under 10 dB. (Refer Fig. 1 and Fig. 2)
 - If output wave form deteriorates, side band appears like Fig. 3 and Fig. 4.

• **Transmission Wave:**

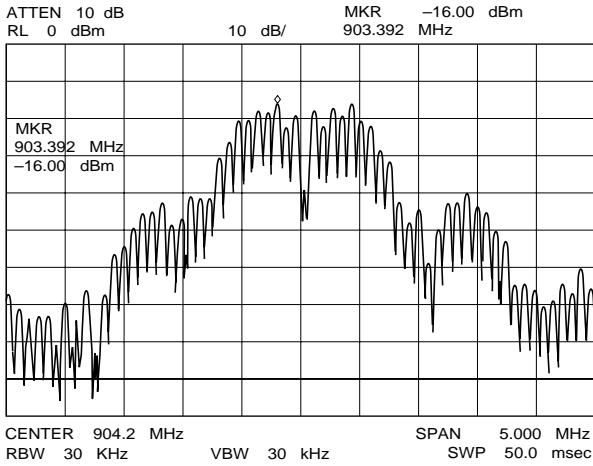

Fig. 1

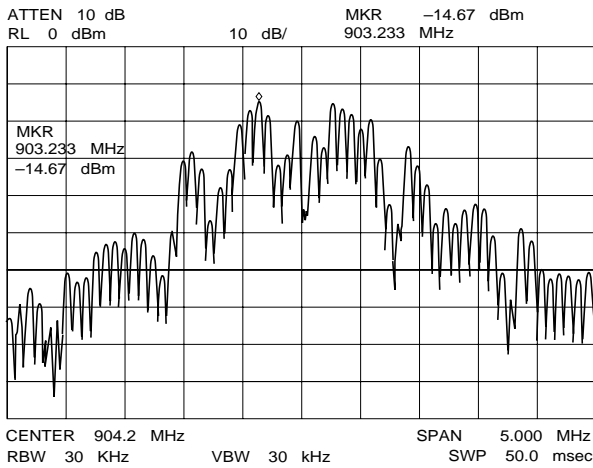

Fig. 2

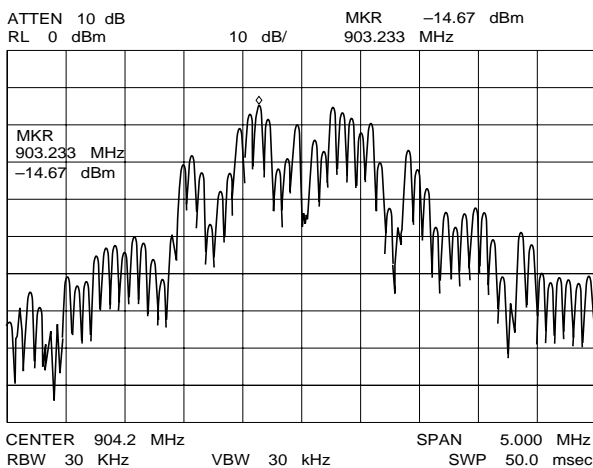

Fig. 3

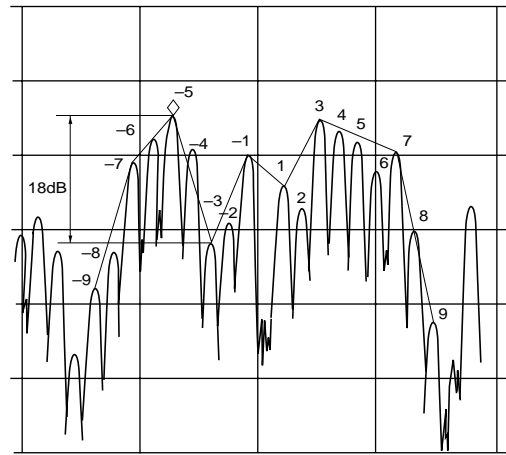

Fig. 4

[Check Center Frequency]

Measuring process

- Setting Spectrum analyzer:
 - Center frequency : 904.2 MHz (CH1)
 - RBW : 10 kHz
 - VBW : 10 kHz
 - Span : 1 MHz
- Setting Test mode:
 - Continuous Transmit mode (CH1 High Power)
 - (Refer to “Test Mode” on page 16)
- Measurement:
 - Measure transmitting wave f_0 (Formula of center frequency)
 - (Refer Fig. 5)
- Specification:
 - 904.2 MHz \pm 27 kHz

• **Center Frequency:**

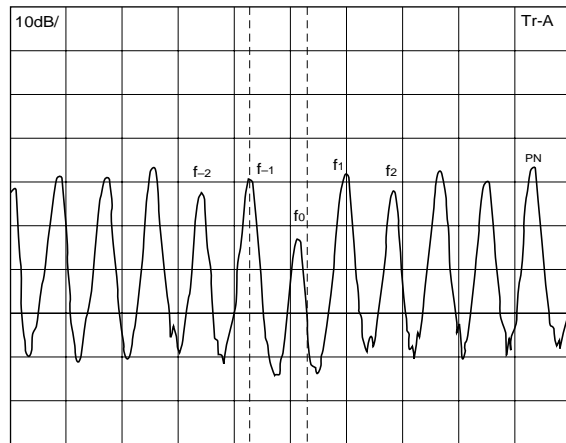

Fig. 5

[Confirm Transmitting output]

Measuring process

- Setting Spectrum analyzer:
 - Center frequency : 904.2 MHz (CH1)
 - RBW : 1 MHz
 - VBW : 100 kHz
 - Span : 5 MHz
- Setting Test mode:
 - Continuous Transmit mode (CH1 High Power)
 - (Refer to “Test Mode” on page 16)

- Measurement:
Measure peak level by Spectrum analyzer.

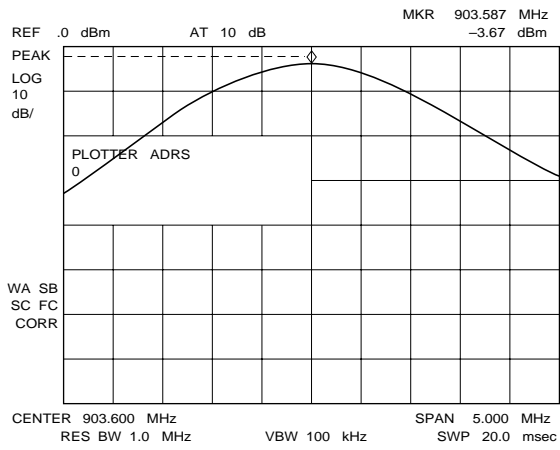

- Specification:
HANDSET MIN -17 dBm
(at High power: Include location loss)
BASE UNIT MIN -18 dBm
(at High power: Include location loss)

SECTION 5 ELECTRICAL ADJUSTMENTS

5-1. BASE UNIT SECTION

- Make the set in Test mode (see page 16)

1. Checking RX I&Q Output Level

Setting:

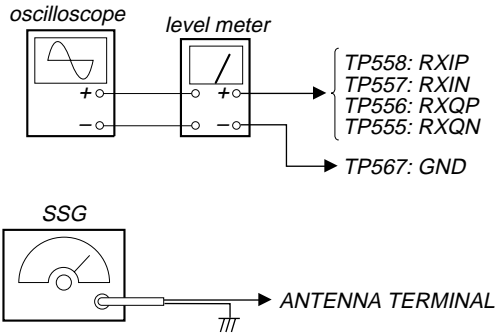

Procedure:

1. Place the base unit in the Continuous Receive mode (CHI, LNA ON, AGC ON).
2. Set the SSG frequency to the frequency on CHI + 300 kHz, and the RF output level to -95 dBm.
3. Measure the output level of RXIN, RXIP, RXQN, and RXQP with a level meter. At this time, confirm with an oscilloscope that a sine wave of 300 kHz is output.
4. Confirm that the measured output level is -25.0 to -19.0 dB V. IF IC501 was replaced (there is no ID data), the output level is -30.0 to -24.0 dB V.
5. Also, execute steps 1 through 4 for the channels 10 and 20.

* For the frequency on each channel, see page 13.

2. Checking TX Center Frequency

Setting:

- short: TP515 ↔ TP567 (GND)

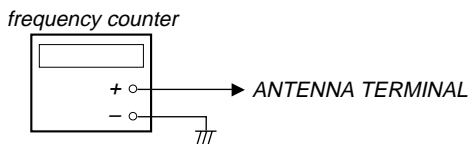

Procedure:

1. Short TP515 (GND) and TP567 (GND) on the BASE MAIN board in the base unit.
2. Place the base unit in the Continuous Transmit more (CH1, High power).
3. Measure the ANT OUT frequency of the RF module in the base unit using a frequency counter.
4. Confirm that the measured frequency is 904.200 MHz ± 27kHz.
5. Also, execute steps 1 through 4 for the channels 10 and 20.

3. Checking TX Output

Setting:

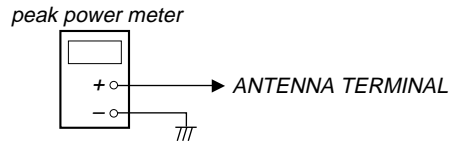

Procedure:

1. Place the base unit in the Continuous Transmit more (CH1, High power).
2. Measure the ANT OUT output of the RF module in the base unit using a peak power meter.
3. Confirm that the measured output is 85 mW (MIN 30 mW).
4. Also, execute steps 1 through 3 for the channels 10 and 20.
CH10: 80 mW (MIN 25 mW)
CH20: 80 mW (MIN 25 mW)

5-2. HANDSET SECTION

- Make the set in Test mode (see page 16)

1. Checking RX I&Q Output Level

Setting:

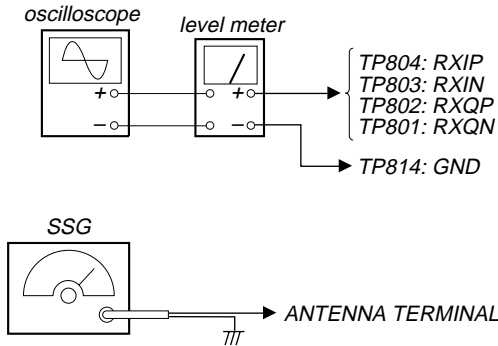

Procedure:

1. Place the handset in the Continuous Receive mode (CHI, LNA AGC ON).
2. Set the SSG frequency to the frequency on CHI + 300 kHz, and the RF output level to -95 dBm.
3. Measure the output level of RXIN, RXIP, RXQN, and RXQP with a level meter. At this time, confirm with an oscilloscope that a sine wave of 300 kHz is output.
4. Confirm that the measured output level is -25.0 to -19.0 dB V. IF IC401 was replaced (there is no ID data), the output level is -30.0 to -24.0 dB V.
5. Also, execute steps 1 through 4 for the channels 10 and 20.

* For the frequency on each channel, see page 13.

2. Checking TX Center Frequency

Setting:

- short: TP820 ↔ TP814 (GND)

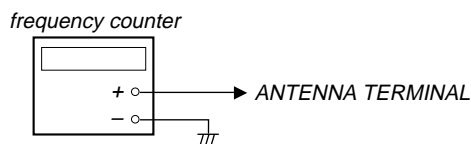

Procedure:

1. Short TP555 (GND) and TP814 (GND) on the HAND MAIN board in the handset.
2. Place the handset in the Continuous Transmit more (CH1, High power).
3. Measure the ANT OUT frequency of the RF module in the handset using a frequency counter.
4. Confirm that the measured frequency is 904.200 MHz ± 27kHz.
5. Also, execute steps 1 through 4 for the channels 10 and 20.

3. Checking TX Output

Setting:

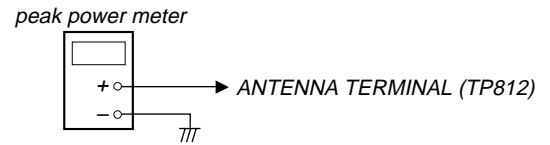

Procedure:

1. Place the handset in the Continuous Transmit more (CH1, High power).
2. Measure the ANT OUT output of the RF module in the handset using a peak power meter.
3. Confirm that the measured output is 62 mW (MIN 25 mW).
4. Also, execute steps 1 through 3 for the channels 10 and 20.
CH10: 64 mW (MIN 25 mW)
CH20: 64 mW (MIN 25 mW)

ADJUSTMENT LOCATION:

[BASE MAIN BOARD] (Conductor Side)

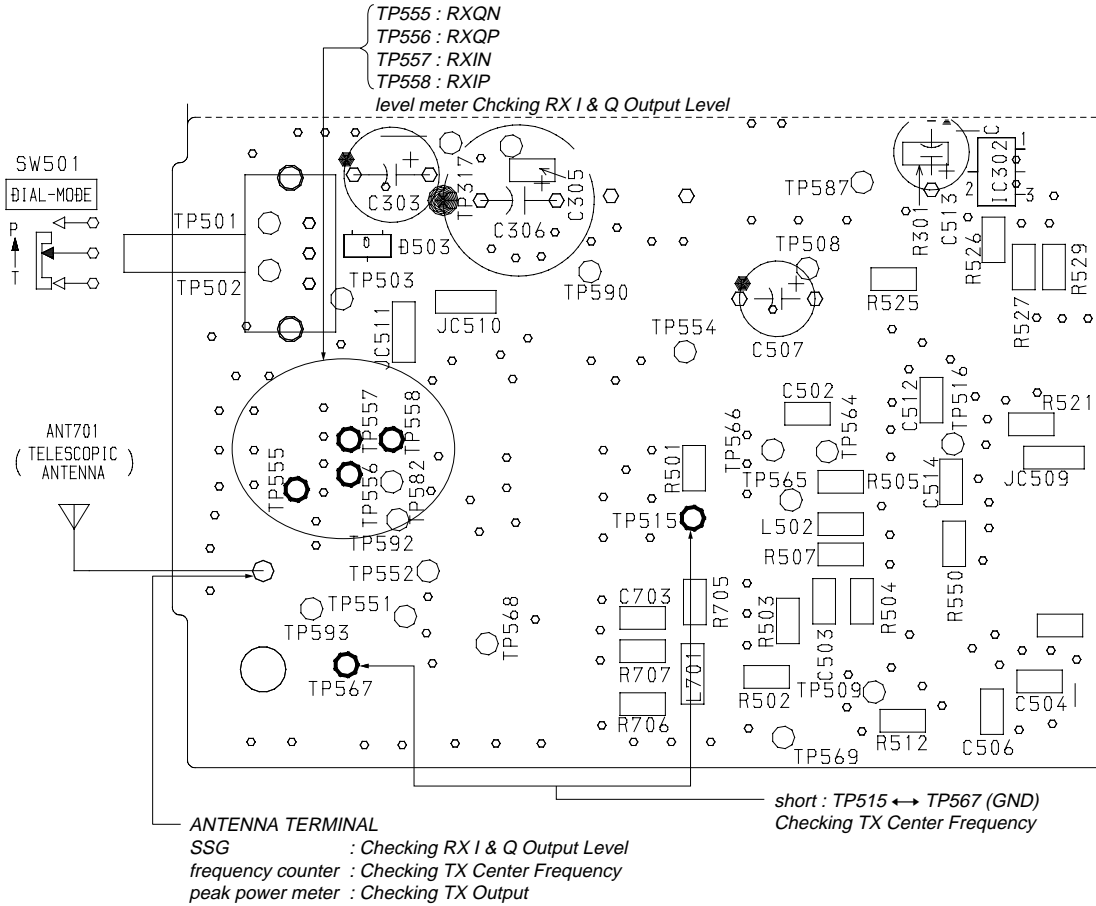

[HAND MAIN BOARD] (Component Side)

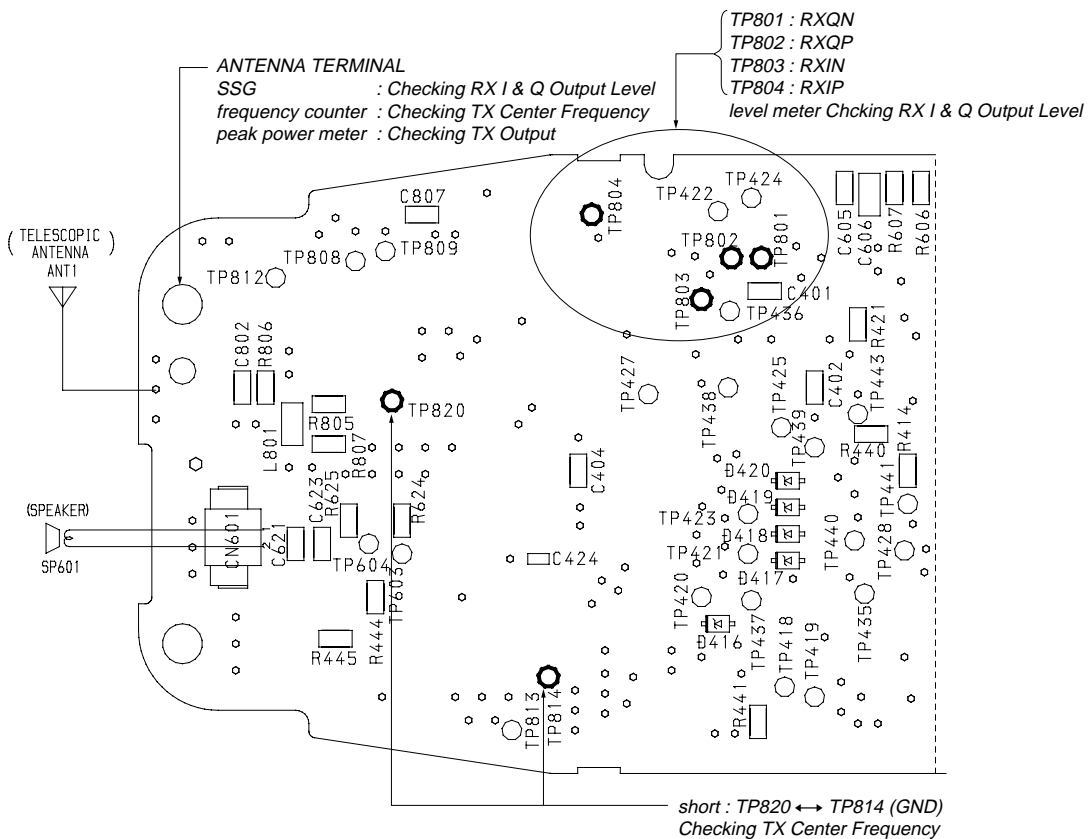

SECTION 6 DIAGRAMS

THIS NOTE IS COMMON FOR PRINTED WIRING BOARDS AND SCHEMATIC DIAGRAMS.
(In addition to this, the necessary note is printed in each block.)

For schematic diagrams.

Note:

- All capacitors are in μF unless otherwise noted. pF : $\mu\mu\text{F}$ 50 WV or less are not indicated except for electrolytics and tantalums.
- All resistors are in Ω and $1/4\text{ W}$ or less unless otherwise specified.
- : panel designation.
- : nonflammable.

Note:

The components identified by mark Δ or dotted line with mark Δ are critical for safety. Replace only with part number specified.

Note:

Les composants identifiés par une marque Δ sont critiques pour la sécurité. Ne les remplacer que par une pièce portant le numéro spécifié.

- B+ : B+ Line.
- Power voltage is dc 9V and fed with regulated dc power supply from external power voltage jack (J301 on the BASE MAIN board).
- Power voltage is dc 12V and fed with regulated dc power supply from modular jack (MJ101 on the BASE MAIN board) with $100\ \Omega$ in series.
- Power voltage is dc 3.6V and fed with regulated dc power supply from battery jack (HAND MAIN board).
- Voltages and waveforms are dc with respect to ground under no-signal conditions.
- no mark : Talk
- Voltages are taken with a VOM (Input impedance $10\ \text{M}\Omega$). Voltage variations may be noted due to normal production tolerances.
- Waveforms are taken with an oscilloscope. Voltage variations may be noted due to normal production tolerances.
- Circled numbers refer to waveforms.
- Signal path.
- : RX
- : TX
- : bell

Note on Printed Wiring Boards:

Note:

- : parts extracted from the component side.
- : Pattern from the side which enables seeing.

WAVEFORMS – BASE UNIT SECTION –

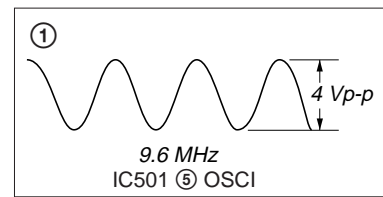

– HANDSET SECTION –

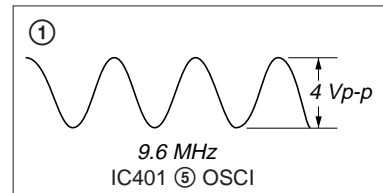

6-1. IC BLOCK DIAGRAMS

• BASE MAIN Board IC502 S-24C01AFJA-TB-01

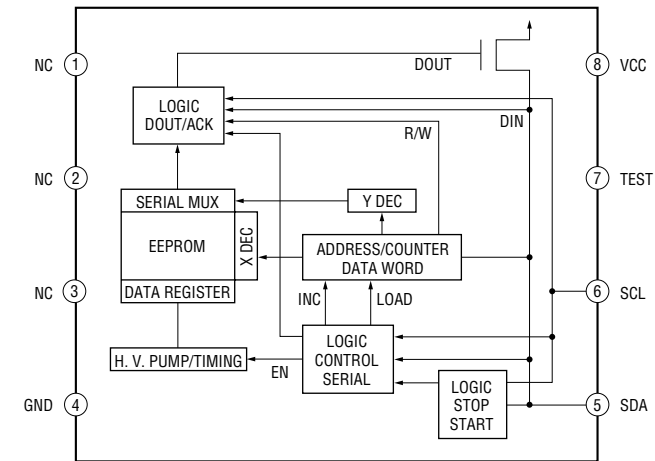

• HAND MAIN Board IC402 AT24C32N-10SI-1.8-TR

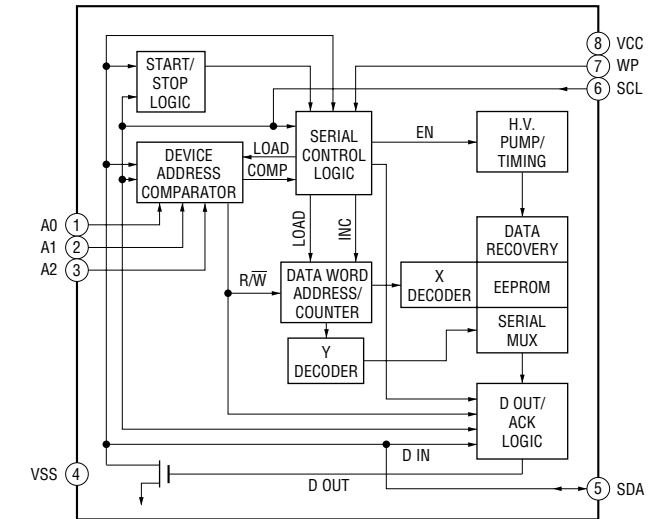

• BASE MAIN Board IC901 MT88E45

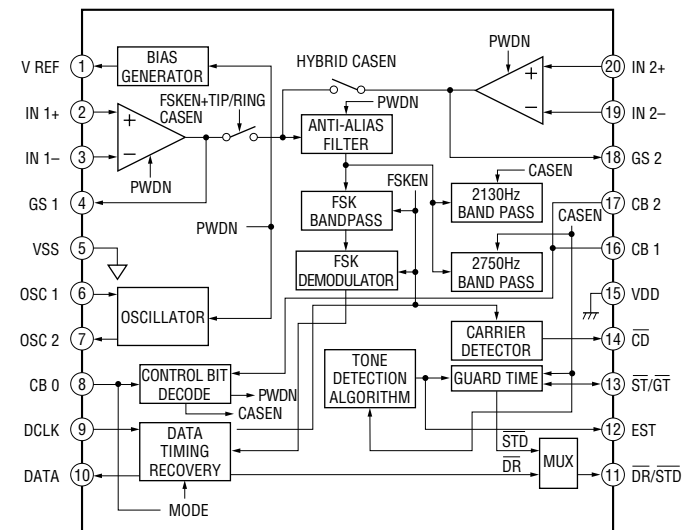

• HAND MAIN Board IC403 TC74VHC86FT (EL)

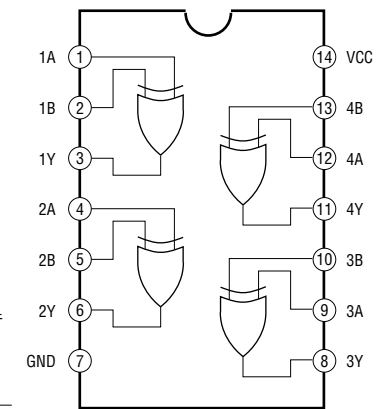

6-2. PRINTED WIRING BOARDS – BASE UNIT/LED SECTION –

【BASE MAIN BOARD】(SIDE A)

• Semiconductor Location

Ref. No.	Location
D323	G-6
D326	D-1
D327	C-2
IC501	F-6
IC901	A-3
Q902	D-4
Q903	D-4
Q904	E-3
Q905	E-2
Q907	F-2
Q908	G-1

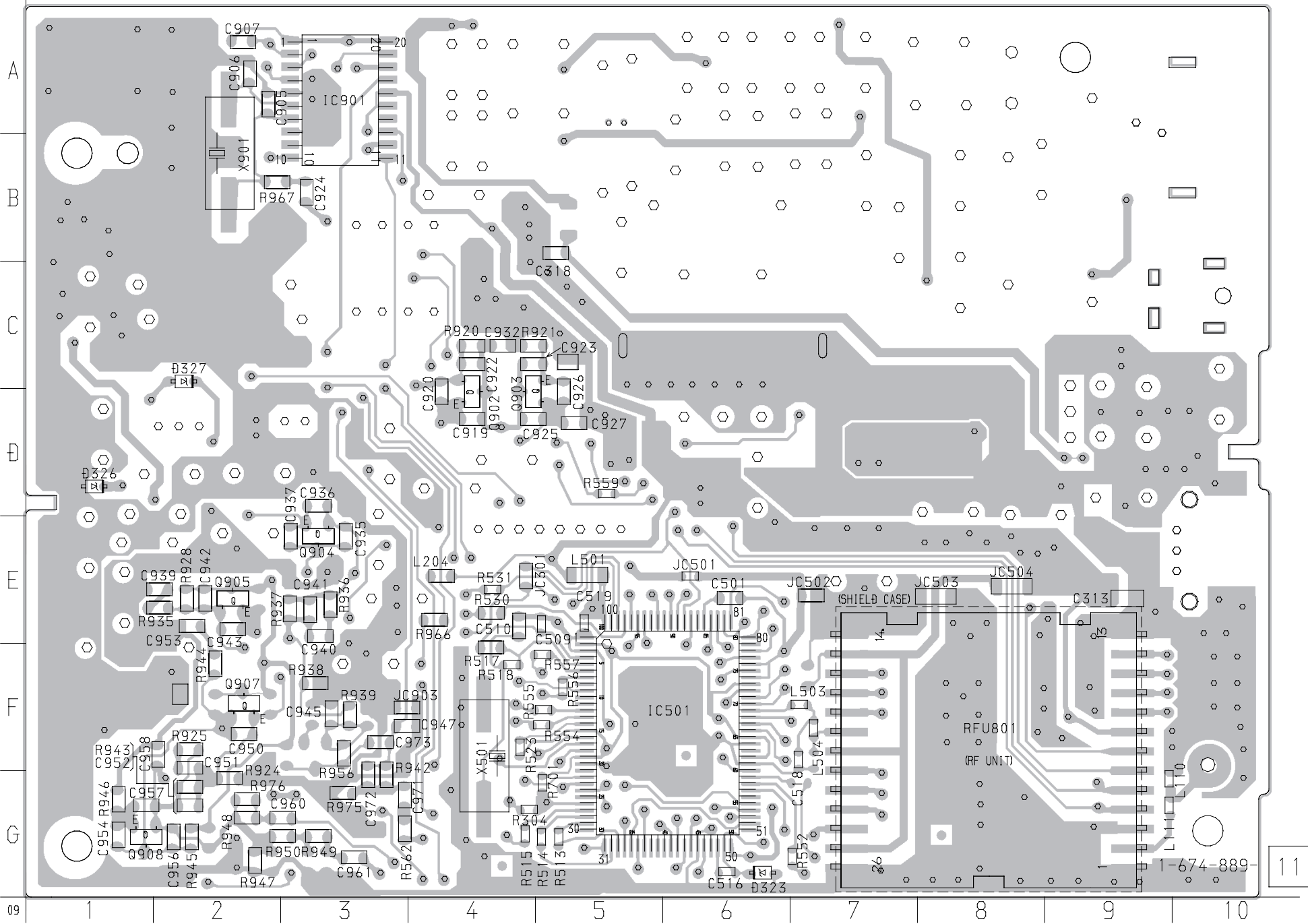

• Semiconductor Location

Ref. No.	Location
D571	A-7
D572	A-6
D573	A-5
D574	A-4
Q571	A-7
Q572	A-6

【LED BOARD】

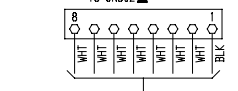
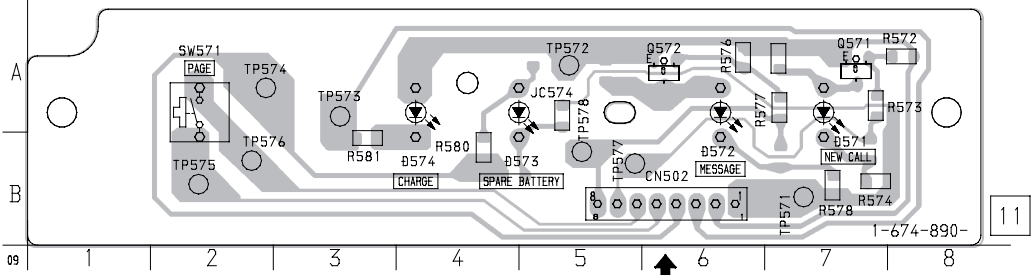

BASE MAIN BOARD
CN501
(Page 27)

【BASE MAIN BOARD】(SIDE B)

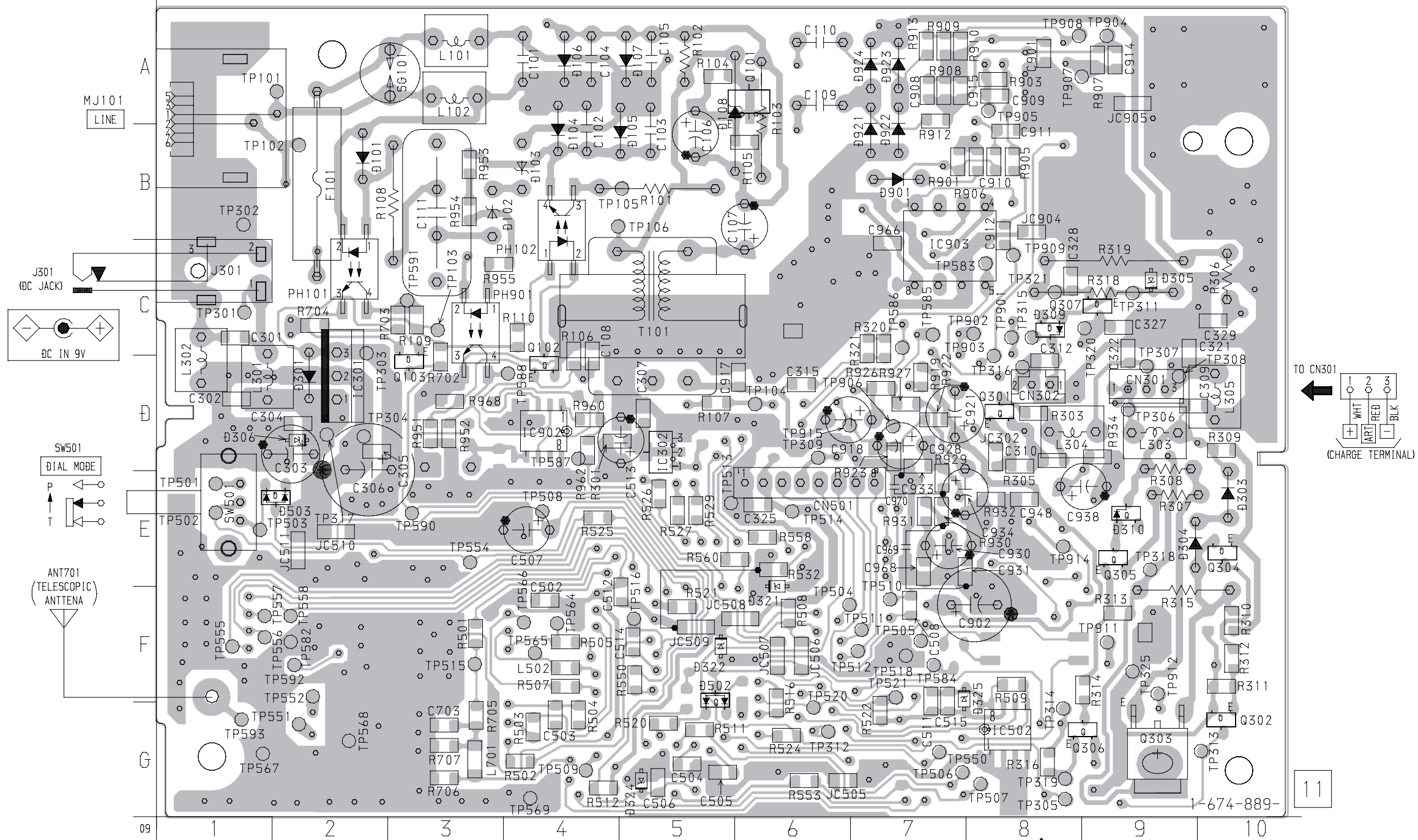

• Semiconductor Location

Ref. No.	Location
D101	B-2
D102	B-3
D103	B-4
D104	B-4
D105	B-5
D106	A-4
D107	A-5
D108	A-6
D301	D-2
D303	E-10
D304	E-9
D305	C-9
D306	D-2
D309	C-8
D310	E-9
D321	F-6
D322	F-5
D324	G-5
D325	F-7
D502	F-5
D503	E-2
D901	B-7
D921	B-7
D922	B-7
D923	A-7
D924	A-7
IC301	D-2
IC302	D-5
IC502	G-8
IC902	D-4
Q101	A-6
Q102	D-4
Q103	D-3
Q301	D-8
Q302	G-10
Q303	G-9
Q304	E-10
Q305	E-9
Q306	G-9
Q307	C-9

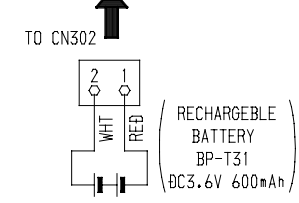
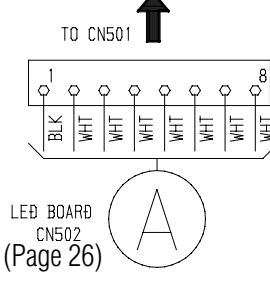
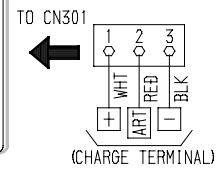

LED BOARD
CN502
(Page 26)

11

6-4. SCHEMATIC DIAGRAMS – BASE UNIT (2/2)/LED SECTION –
 • See page 26, 27 for Printed Wiring Board.

19 20 21 22 23 24 25 26 27 28 29 30 31 32 33 34 35 36

A
B
C
D
E
F
G
H
I
J
K
L
M

TO
BASE MAIN
BOARD (1/2)
(Page 28)

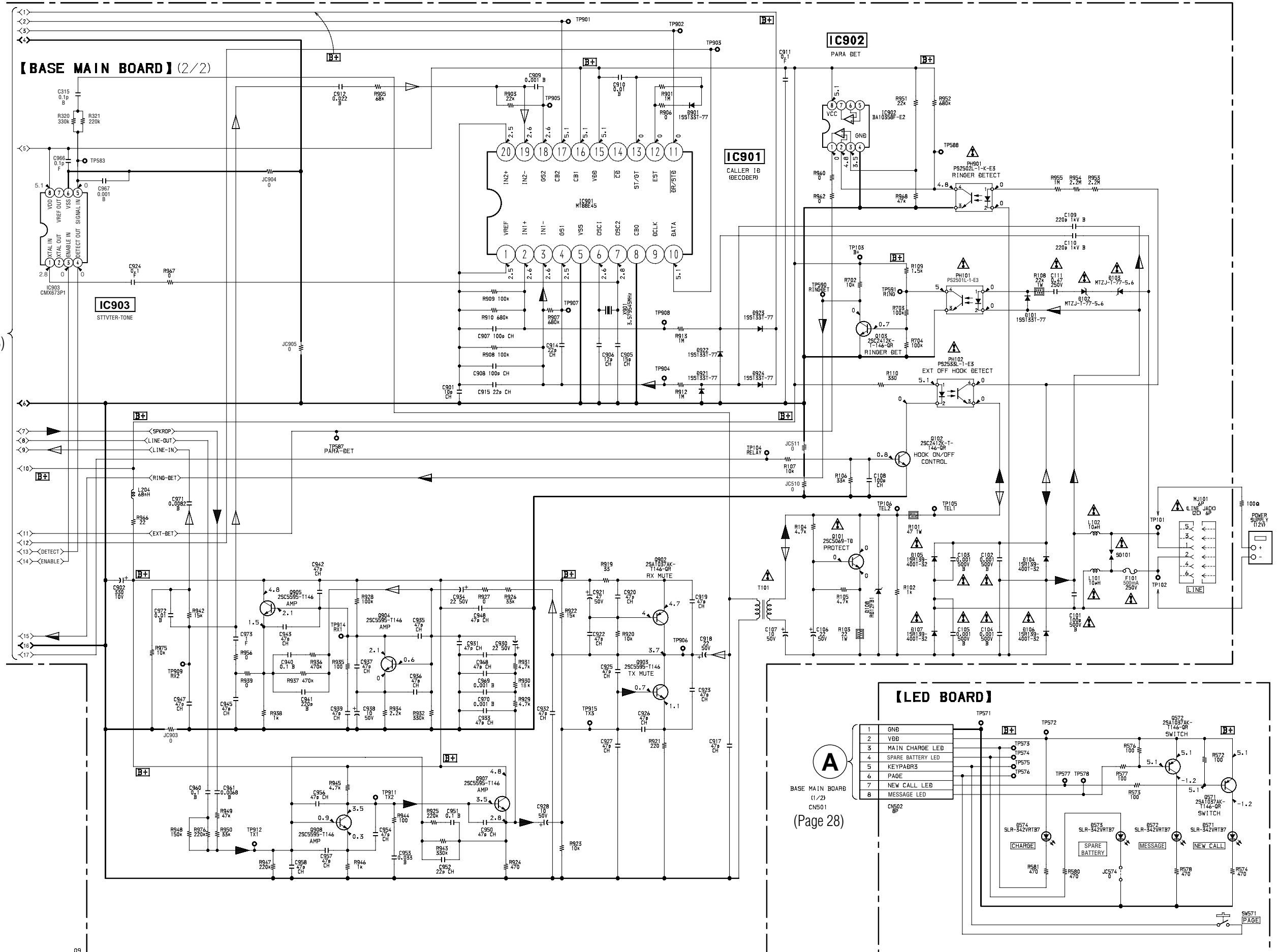

6-5. PRINTED WIRING BOARD – HANDSET SECTION –

• Semiconductor Location

Ref. No.	Location
D201	D-12
D202	D-10
D203	D-11
D205	D-10
D206	B-8
D207	C-11
D208	D-12
D209	C-11
D401	A-4
D410	B-7
D413	A-5
D414	B-7
D415	A-7
D422	A-4
D601	B-13
D801	A-2
IC201	C-10
IC401	B-4
IC402	B-6
IC403	B-7
Q201	D-9
Q202	C-10
Q203	C-10
Q204	C-11
Q405	B-11
Q601	B-13

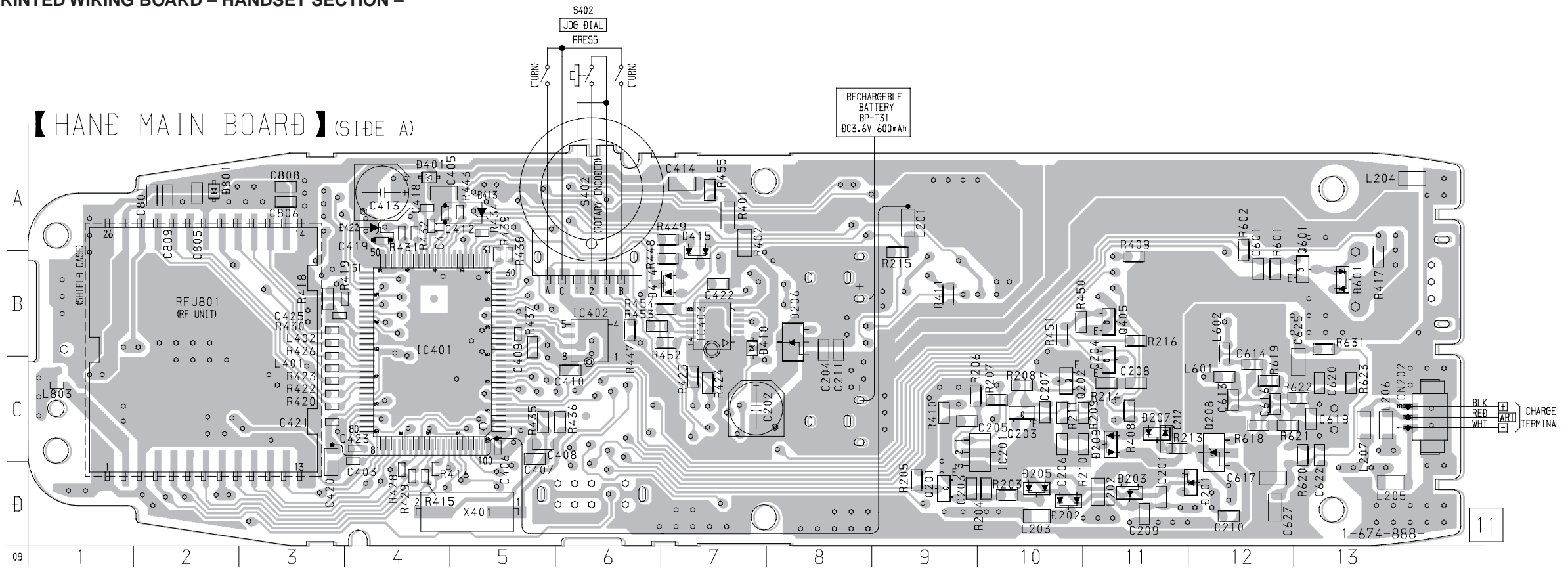

• Semiconductor Location

Ref. No.	Location
D404	C-11
D405	B-11
D406	C-9
D407	B-9
D408	C-4
D409	B-4
D411	B-2
D412	B-2
D416	A-4
D417	B-4
D418	B-4
D419	B-4
D421	B-4
D423	B-3
Q402	B-6
Q404	B-2

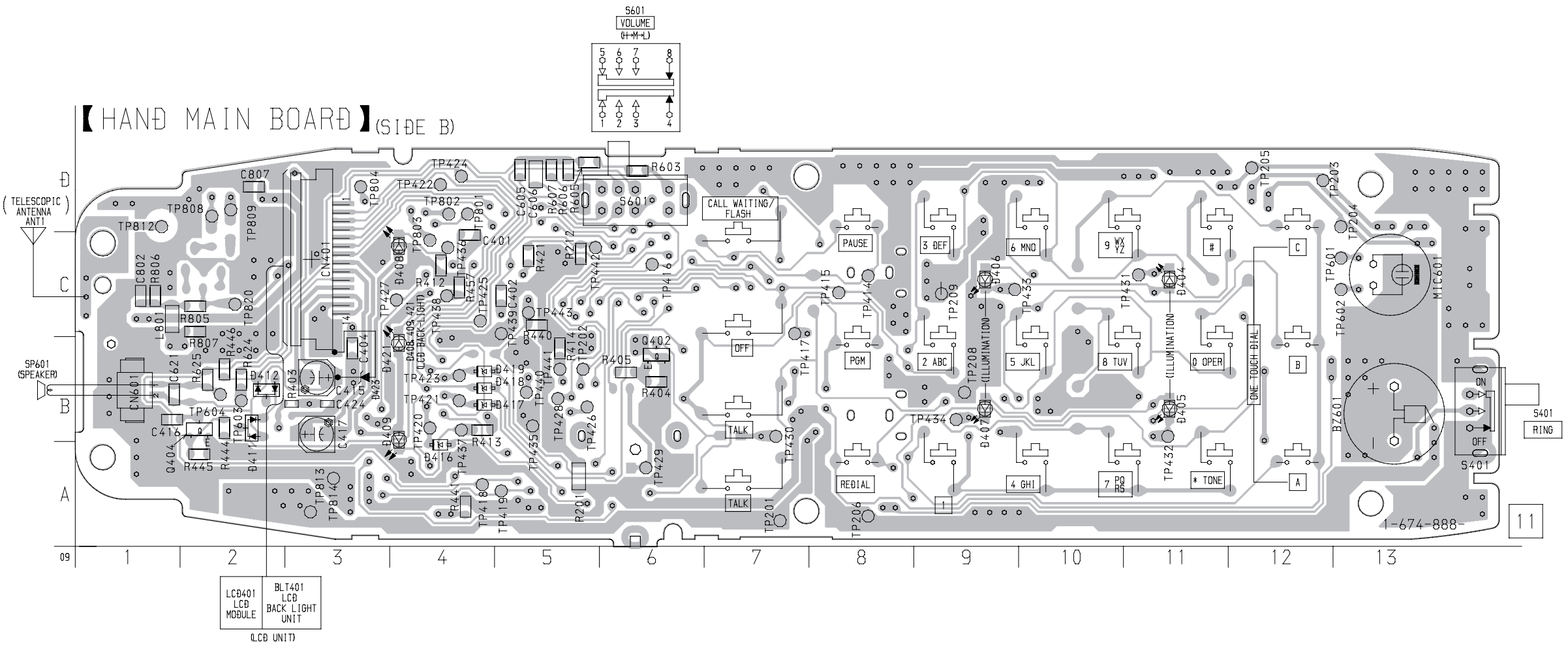

6-6. SCHEMATIC DIAGRAM – HANDSET SECTION –
• See page 25 for Waveforms. • See page 33 for IC Pin Functions.

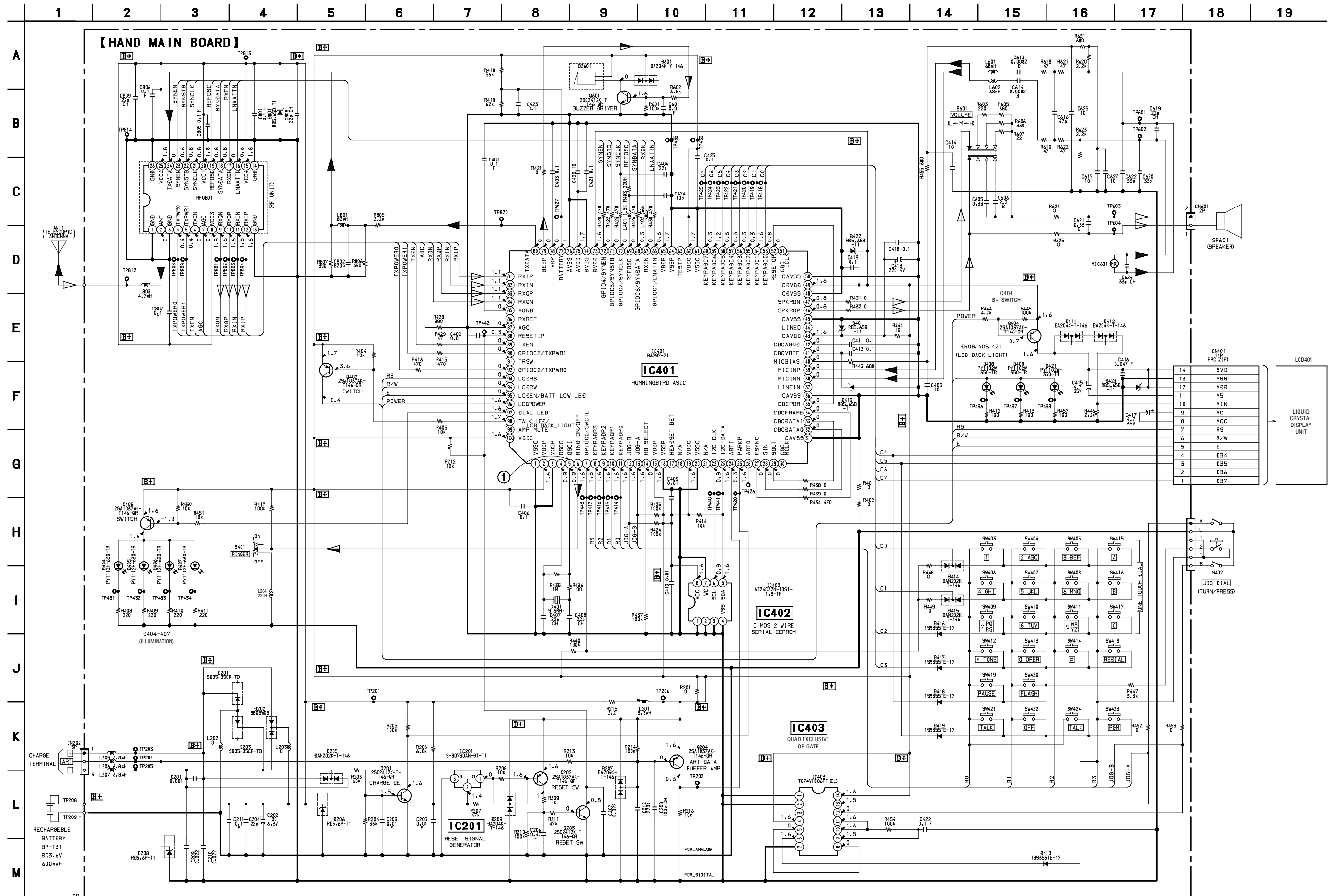

6-7. IC PIN FUNCTIONS

• BASE MAIN BOARD IC501 R6797-71 (HUMMINGBIRD ASIC)

Pin No.	Pin Name	I/O	Function
1	VSSC	-	VSS supply to core
2	VDDP	-	VDD supply to pad ring
3	VSSP	-	VSS supply to pad ring
4	OSCO	O	9.6 MHz crystal oscillator output
5	OSCI	I	9.6 MHz crystal oscillator input
6	RIP/BRANCHP	I	Detection signal input of the ringer coming
7	SW CTL	I	Switch control read input
8	KEYPADC4	-	Not used (open)
9	KEYPADC3	-	Keypad read input (for page switch)
10	KEYPADC2	-	Not used (open)
11	KEYPADC1	-	Not used (open)
12	NEW CALL LED	O	NEW CALL LED output
13	MESSAGE LED	O	VMWI LED output
14	HB-SELECT	I	HAND/BASE select input
15	VDDP	-	VDD supply to pad ring
16	VSSP	-	VSS supply to pad ring
17	CHG CTL	O	Charge detection control terminal
18	BATT CHACK	I	Battery voltage detection input terminal
19	VDDC	-	VDD supply to core
20	VSSC	-	VSS supply to core
21	N/A	-	Not used (open)
22	I2C-CLK	O	Clock signal output to the EEPROM
23	I2C-DATA	I/O	Two-way data bus with the EEPROM
24	ARTI	I	ART input
25	PARKP	I	Park input; active low on base station, active high on handset
26	ARTO	O	ART output
27	FSYNC	-	Frame sync
28	SIN	I	Serial data input
29	SOUT	O	Serial data output
30	CDCMCLK	-	Main clock input Not used (open)
31	CAVSS	I	Analog 0V power supply
32	CDCDATA0	O	Codec data output
33	CDCDATA1	I	Codec data input
34	CDCFRAME	-	Codec frame
35	CDCPOR	I	Reset input, active low
36	CAVSS	I	Analog 0V power supply
37	LINEIN	I	Analog input to line pre-amp, ADC channel
38	MICINN	-	Negative differential analog input to microphone pre-amp, ADC channel Not used (open)
39	MICINP	-	Positive differential analog input to microphone pre-amp, ADC channel Not used (open)
40	MICBIAS	-	2.2V nominal DC bias source for electret microphone Not used (open)
41	CDCVREF	O	Analog reference voltage output Bypass to AVSS with 0.1mF capacitor
42	CDCAGND	O	Analog ground bias output Bypass to AVSS with 0.1mF capacitor
43	CAVDD	I	Analog power supply
44	LINEO	O	Line driver output, DAC channel
45	CAVSS	I	Analog 0V power supply
46	SPKROP	O	Positive speaker driver output, DAC channel
47	SPKRON	-	Negative speaker driver output, DAC channel Not used (open)
48	CDVSS	I	Digital 0V power supply
49	CDVDD	I	Digital power supply, 2.7-5.5 Volts
50	CAVSS	I	Analog 0V power supply

Pin No.	Pin Name	I/O	Function
51	CDCICLK	-	Bit clock input/output for digital serial interface Not used (open)
52	RESETOP	O	Codec reset
53	KEYPADR1	-	Not used (open)
54	KEYPADR2	I	Dial mode switch input terminal
55	KEYPADR3	I	Dial mode switch input terminal
56	KEYPADR4	-	Not used (open)
57	NOMAL/TEST MODE	-	TEST MODE terminal
58	PAGE	O	Page switch on/off control signal output terminal
59	KEYPADC6	-	Not used
60	TONE/PULSE	I	Dial mode switch input terminal
61	VSSC	-	VSS supply to core
62	VDDC	-	VDD supply to core
63	TEST P	-	Not used (open)
64	VSSP	-	VSS supply to pad ring
65	VDDP	-	VDD supply to pad ring
66	GPIOC1/LNAATN	O	LNA select
67	RXEN	O	Receive enable
68	GPIOC6/SYNCDATA	O	Synthesizer data
69	REFOSC	-	9.6 MHz clock used by synthesizer
70	GPIOC7/SYNCLK	O	Synthesizer clock
71	GPIOC5/SYNSTB	O	Synthesizer strobe
72	GPIOC4/SYNEN	O	Synthesizer power
73	DVDD	-	VDD supply to A/D converters
74	DVSS	-	VSS supply to A/D converters
75	AVDD	-	VDD supply to analog
76	AVSS	-	VSS supply to analog
77	BATTERY	I	Battery voltage input
78	VRP	O	Analog voltage reference output
79	AUXDAC	-	AFC DAC output Not used (open)
80	TXDATA	O	Transmitter data
81	RXIP	I	Receiver I positive differential input
82	RXIN	I	Receiver I negative differential input
83	RXQP	I	Receiver Q positive differential input
84	RXQN	I	Receiver Q negative differential input
85	AGND	O	Analog ground
86	RXREF	-	Receiver ADC reference Not used (open)
87	AGC	O	AGC control
88	RESETIP	I	Power-on reset RC input; active low
89	TXEN	O	Transmit enable
90	GPIOC3/TXPWR1	O	PA power level select
91	TRSW	O	Transmit=1/receive=0 select Not used (open)
92	GPIOC2/TXPWR0	O	PA power level select
93	N/A	-	Not used (open)
94	EXT DET	O	EXT DET output
95	DETECT IN	-	Not used (open)
96	ENABLE OUT	-	Not used (open)
97	MITEL FSKEN	-	Not used (open)
98	MITEL STD	I/O	Not used (open)
99	OHP	O	Hook on/off control signal output terminal
100	VDDC	-	VDD supply to core

• **HAND MAIN BOARD IC401 R6797-71 (HUMMINGBIRD ASIC)**

Pin No.	Pin Name	I/O	Function
1	VSSC	–	VSS supply to core
2	VDDP	–	VDD supply to pad ring
3	VSSP	–	VSS supply to pad ring
4	OSCO	O	9.6 MHz crystal oscillator output
5	OSCI	I	9.6 MHz crystal oscillator input
6	RING ON/OFF	I	Detection signal input of the ringer coming
7	GPOC0/SWCTL	I	Switch control read input
8	KEYPADR3	I	Keypad read input
9	KEYPADR2	I	Keypad read input
10	KEYPADR1	I	Keypad read input
11	KEYPADR0	I	Keypad read input
12	JOG-B	–	Not used (open)
13	JOG-A	–	Not used (open)
14	HB-SELECT	I	HAND/BASE select input
15	VDDP	–	VDD supply to pad ring
16	VSSP	–	VSS supply to pad ring
17	HEADSET DET	–	Not used (open)
18	N/A	–	Not used (open)
19	VDDC	–	VDD supply to core
20	VSSC	–	VSS supply to core
21	N/A	I/O	Not used (open)
22	I2C-CLK	O	Clock signal output to the EEPROM
23	I2C-DATA	I/O	Two-way data bus with the EEPROM
24	ARTI	I	ART input
25	PARKP	I	Park input; active low on base station, active high on handset
26	ARTO	O	ART output
27	FSYNC	–	Frame sync
28	SIN	I	Serial data input
29	SOUT	O	Serial data output
30	CDCMCLK	–	Main clock input Not used (open)
31	CAVSS	I	Analog 0V power supply
32	CDCDATA0	O	Codec data output
33	CDCDATA1	I	Codec data input
34	CDCFRAME	–	Codec flame
35	CDCPOR	I	Reset input, active low
36	CAVSS	I	Analog 0V power supply
37	LINEIN	I	Analog input to line pre-amp, ADC channel Not used (open)
38	MICINN	I	Negative differential analog input to microphone pre-amp, ADC channel
39	MICINP	I	Positive differential analog input to microphone pre-amp, ADC channel
40	MICBIAS	O	2.2V nominal DC bias source for electret microphone
41	CDCVREF	O	Analog reference voltage output Bypass to AVSS with 0.1mF capacitor
42	CDCAGND	O	Analog ground bias output Bypass to AVSS with 0.1mF capacitor
43	CAVDD	I	Analog power supply
44	LINEO	O	Line driver output, DAC channel Not used (open)
45	CAVSS	I	Analog 0V power supply
46	SPKROP	O	Positive speaker driver output, DAC channel
47	SPKRON	O	Negative speaker driver output, DAC channel
48	CDVSS	I	Digital 0V power supply
49	CDVDD	I	Digital power supply, 2.7-5.5 Volts
50	CAVSS	I	Analog 0V power supply

Pin No.	Pin Name	I/O	Function
51	CDCICLK	–	Bit clock input/output for digital serial interface Not used (open)
52	RESETOP	O	Codec reset
53	KEYPADC0	–	Keypad bidirectional control/LCD data
54	KEYPADC1	–	Keypad bidirectional control/LCD data
55	KEYPADC2	–	Keypad bidirectional control/LCD data
56	KEYPADC3	–	Keypad bidirectional control/LCD data
57	KEYPADC4	–	Keypad bidirectional control/LCD data
58	KEYPADC5	–	Keypad bidirectional control/LCD data
59	KEYPADC6	–	Keypad bidirectional control/LCD data
60	KEYPADC7	–	Not used (open)
61	VSSC	–	VSS supply to core
62	VDDC	–	VDD supply to core
63	TESTP	–	Not used (open)
64	VSSP	–	VSS supply to pad ring
65	VDDP	–	VDD supply to pad ring
66	GPIOC1/LNAATN	O	LNA select
67	RXEN	O	Receive enable
68	GPIOC6/SYNCDATA	O	Synthesizer data
69	REFOSC	–	9.6 MHz clock used by synthesizer
70	GPIOC7/SYNCLK	O	Synthesizer clock
71	GPIOC5/SYNSTB	O	Synthesizer strobe
72	GPIOC4/SYNEN	O	Synthesizer power
73	DVDD	–	VDD supply to A/D converters
74	DVSS	–	VSS supply to A/D converters
75	AVDD	–	VDD supply to analog
76	AVSS	–	VSS supply to analog
77	BATTERY	I	Battery voltage input
78	VRP	O	Analog voltage reference output
79	BEEP	O	AFC DAC output
80	TXDATA	O	Transmitter data
81	RXIP	I	Receiver I positive differential input
82	RXIN	I	Receiver I negative differential input
83	RXQP	I	Receiver Q positive differential input
84	RXQN	I	Receiver Q negative differential input
85	AGND	O	Analog ground
86	RXREF	–	Receiver ADC reference Not used (open)
87	AGC	O	AGC control
88	RESETIP	I	Power-on reset RC input; active low
89	TXEN	O	Transmit enable
90	GPIOC3/TXPWR1	O	PA power level select
91	TRSW	–	Transmit=1/receive=0 select Not used (open)
92	GPIOC2/TXPWR0	O	PA power level select
93	LCD RS	–	Not used (open)
94	LCD RW	–	Not used (open)
95	LCD EN/BATT LOW LED	O	BATT LOW LED output
96	LCD POWER	–	Not used (open)
97	DIAL LED	I/O	DIAL LED output
98	TALK LED/LCD BACK LIGHT	O	TALK LED output
99	AMP MUTE	–	Not used (open)
100	VDDC	–	VDD supply to core

SECTION 7 EXPLODED VIEWS

NOTE:

- Items marked “*” are not stocked since they are seldom required for routine service. Some delay should be anticipated when ordering these items.
- The mechanical parts with no reference number in the exploded views are not supplied.
- Hardware (# mark) list and accessories and packing materials are given in the last of this parts list.
- Abbreviation
CND : Canadian model

7-1. HANDSET SECTION

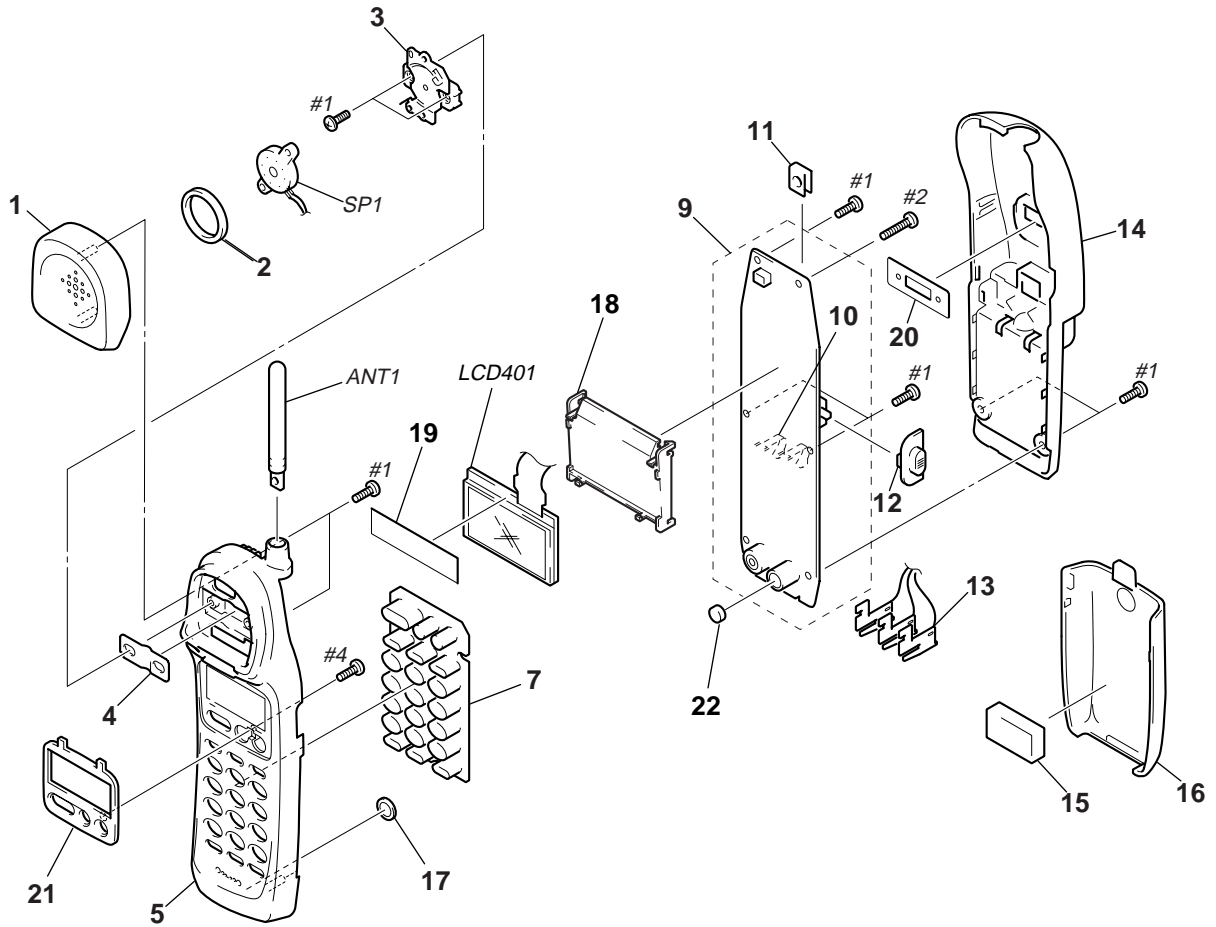

Ref. No.	Part No.	Description	Remark	Ref. No.	Part No.	Description	Remark
1	3-034-812-01	PAD, EAR		14	3-034-815-01	CABINET (REAR)	
2	3-014-329-01	CUSHION (SP)		15	3-018-253-01	CUSHION (BATTERY)	
* 3	X-3377-753-1	HINGEASSY		16	3-034-816-01	LID(HAND), BATTERY CASE	
4	3-034-810-01	SPRING, LEAF		* 17	3-033-764-01	CUSHION (MIC)	
5	3-034-814-01	CABINET (FRONT)		18	3-034-821-01	HOLDER (LCD)	
* 6	3-935-519-01	CUSHION (BUZZER)		19	3-039-836-01	SHEET (LCD)	
7	1-771-617-11	SWITCH, RUBBER KEY		20	3-039-837-01	SHEET (H/S REAR)	
* 9	A-3622-339-A	HAND(MAIN) BOARD, COMPLETE		21	3-034-817-01	PANEL (LED)	
10	3-034-819-01	TERMINAL (H BATTERY) CHARGE		22	3-038-844-01	MICROPHONE CUSHION	
11	3-038-270-01	SHEET(ADHESIVE)		ANT1	1-754-081-11	ANTENNA, HELICAL	
12	3-034-820-01	BUTTON (VOL)		LCD401	1-418-604-11	LCD UNIT	
13	3-034-818-01	TERMINAL (HAND), CHARGE		SP1	1-505-695-11	SPEAKER (2.1CM)	

7-2. BASE UNIT SECTION

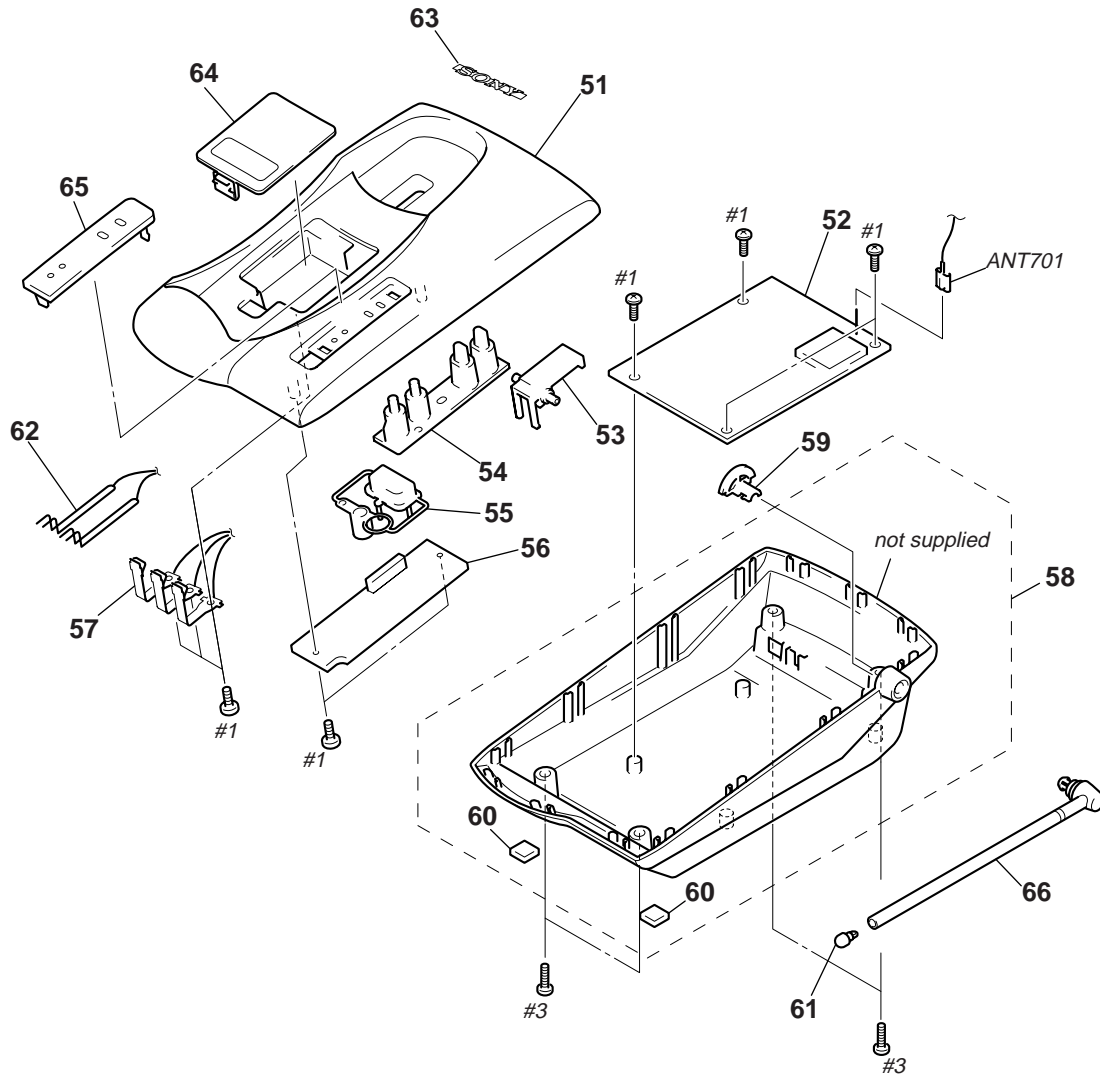

Ref. No.	Part No.	Description	Remark	Ref. No.	Part No.	Description	Remark
51	3-034-827-01	CABINET (UPPER)		60	3-936-696-21	FOOT,RUBBER	
* 52	A-3622-341-A	BASE(MAIN) BOARD, COMPLETE		61	3-037-080-01	CAP(ANTENNA)	
53	3-034-830-01	HOLDER (HAND SET)		62	3-034-834-01	TERMINAL (B BATTERY), CHARGE	
54	3-034-832-01	LENS(C-ID)		63	4-946-905-11	ENBLEM (NO.4.5), SONY	
55	3-034-831-01	BUTTON (H.L.)		64	3-034-829-01	LID(BASE), BATTERY CASE	
* 56	1-674-890-11	LED BOARD		65	3-034-835-01	PANEL(C-ID)	
57	3-034-833-01	TERMINAL (BASE), CHARGE		66	3-037-079-01	BODY(ANTENNA)	
58	X-3377-755-1	CABINET (LOWER) ASSY		ANT701	3-038-540-01	TERMINAL, ANTENNA	
59	3-037-081-01	PLUG(ANTENNA)					

SECTION 8 ELECTRICAL PARTS LIST

BASE (MAIN)

Note:

The components identified by mark Δ or dotted line with mark Δ are critical for safety. Replace only with part number specified.

Les composants identifiés par une marque Δ sont critiques pour la sécurité. Ne les remplacer que par une pièce portant le numéro spécifié.

When indicating parts by reference number, please include the board name.

- Due to standardization, replacements in the parts list may be different from the parts specified in the diagrams or the components used on the set.
- -XX, -X mean standardized parts, so they may have some difference from the original one.
- Items marked "*" are not stocked since they are seldom required for routine service. Some delay should be anticipated when ordering these items.
- RESISTORS
All resistors are in ohms
METAL: Metal-film resistor
METAL OXIDE: Metal Oxide-film resistor
F : nonflammable

- SEMICONDUCTORS
In each case, u: μ , for example:
uA...: μ A..., uPA...: μ PA..., uPB...: μ PB...,
uPC...: μ PC..., uPD...: μ PD...
- CAPACITORS
uF : μ F
- COILS
uH : μ H
- Abbreviation
CND : Canadian model

Ref. No.	Part No.	Description	Remark	Ref. No.	Part No.	Description	Remark
*	A-3622-341-A	BASE (MAIN) BOARD, COMPLETE *****		C513	1-126-964-11	ELECT 10uF	20% 50V
		< CAPACITOR >		C514	1-163-038-00	CERAMIC CHIP 0.1uF	25V
				C515	1-163-038-00	CERAMIC CHIP 0.1uF	25V
Δ C101	1-162-117-00	CERAMIC 100PF	10% 500V	C516	1-164-156-11	CERAMIC CHIP 0.1uF	25V
Δ C102	1-162-318-11	CERAMIC 0.001uF	10% 500V	C518	1-162-925-11	CERAMIC CHIP 68PF	5% 50V
Δ C103	1-162-318-11	CERAMIC 0.001uF	10% 500V	C519	1-164-156-11	CERAMIC CHIP 0.1uF	25V
Δ C104	1-162-318-11	CERAMIC 0.001uF	10% 500V	C703	1-163-139-00	CERAMIC CHIP 820PF	5% 50V
Δ C105	1-162-318-11	CERAMIC 0.001uF	10% 500V	C901	1-163-227-11	CERAMIC CHIP 10PF	0.5PF 50V
C106	1-128-131-11	ELECT 22uF	20% 50V	C902	1-126-924-11	ELECT 330uF	20% 10V
C107	1-126-261-00	ELECT 10uF	20% 50V	C905	1-163-231-11	CERAMIC CHIP 15PF	5% 50V
C108	1-163-251-11	CERAMIC CHIP 100PF	5% 50V	C906	1-163-229-11	CERAMIC CHIP 12PF	5% 50V
C109	1-107-423-11	CERAMIC 220PF	10% 1KV	C907	1-163-251-11	CERAMIC CHIP 100PF	5% 50V
C110	1-107-423-11	CERAMIC 220PF	10% 1KV	C908	1-163-251-11	CERAMIC CHIP 100PF	5% 50V
Δ C111	1-136-193-11	FILM 0.47uF	10% 250V	C909	1-163-009-11	CERAMIC CHIP 0.001uF	10% 50V
C301	1-163-033-00	CERAMIC CHIP 0.022uF	50V	C910	1-163-021-11	CERAMIC CHIP 0.01uF	10% 50V
C302	1-163-033-00	CERAMIC CHIP 0.022uF	50V	C911	1-163-038-00	CERAMIC CHIP 0.1uF	25V
C303	1-126-963-11	ELECT 4.7uF	20% 50V	C912	1-163-037-11	CERAMIC CHIP 0.022uF	10% 25V
C304	1-163-038-91	CERAMIC CHIP 0.1uF	25V	C914	1-163-235-11	CERAMIC CHIP 22PF	5% 50V
C305	1-163-009-11	CERAMIC CHIP 0.001uF	10% 50V	C915	1-163-235-11	CERAMIC CHIP 22PF	5% 50V
C306	1-126-916-11	ELECT 1000uF	20% 6.3V	C917	1-163-243-11	CERAMIC CHIP 47PF	5% 50V
C307	1-164-505-11	CERAMIC CHIP 2.2uF	16V	C918	1-126-965-11	ELECT 22uF	20% 50V
C309	1-164-489-11	CERAMIC CHIP 0.22uF	10% 16V	C919	1-163-243-11	CERAMIC CHIP 47PF	5% 50V
C310	1-163-001-11	CERAMIC CHIP 220PF	10% 50V	C920	1-163-243-11	CERAMIC CHIP 47PF	5% 50V
C312	1-163-037-11	CERAMIC CHIP 0.022uF	10% 25V	C921	1-126-967-11	ELECT 47uF	20% 50V
C313	1-162-638-11	CERAMIC CHIP 1uF	16V	C922	1-163-243-11	CERAMIC CHIP 47PF	5% 50V
C315	1-164-004-11	CERAMIC CHIP 0.1uF	10% 25V	C923	1-163-243-11	CERAMIC CHIP 47PF	5% 50V
C318	1-163-009-11	CERAMIC CHIP 0.001uF	10% 50V	C924	1-163-038-00	CERAMIC CHIP 0.1uF	25V
C321	1-163-009-11	CERAMIC CHIP 0.001uF	10% 50V	C925	1-163-243-11	CERAMIC CHIP 47PF	5% 50V
C322	1-163-001-11	CERAMIC CHIP 220PF	10% 50V	C926	1-163-243-11	CERAMIC CHIP 47PF	5% 50V
C325	1-164-489-11	CERAMIC CHIP 0.22uF	10% 16V	C927	1-163-243-11	CERAMIC CHIP 47PF	5% 50V
C327	1-163-009-11	CERAMIC CHIP 0.001uF	10% 50V	C928	1-126-964-11	ELECT 10uF	20% 50V
C328	1-163-009-11	CERAMIC CHIP 0.001uF	10% 50V	C930	1-126-965-11	ELECT 22uF	20% 50V
C329	1-164-489-11	CERAMIC CHIP 0.22uF	10% 16V	C931	1-163-243-11	CERAMIC CHIP 47PF	5% 50V
C501	1-163-038-00	CERAMIC CHIP 0.1uF	25V	C932	1-163-243-11	CERAMIC CHIP 47PF	5% 50V
C502	1-163-038-00	CERAMIC CHIP 0.1uF	25V	C933	1-163-243-11	CERAMIC CHIP 47PF	5% 50V
C503	1-163-235-11	CERAMIC CHIP 22PF	5% 50V	C934	1-126-965-11	ELECT 22uF	20% 50V
C504	1-163-038-00	CERAMIC CHIP 0.1uF	25V	C935	1-163-243-11	CERAMIC CHIP 47PF	5% 50V
C505	1-163-038-00	CERAMIC CHIP 0.1uF	25V	C936	1-163-243-11	CERAMIC CHIP 47PF	5% 50V
C506	1-163-038-00	CERAMIC CHIP 0.1uF	25V	C937	1-163-243-11	CERAMIC CHIP 47PF	5% 50V
C507	1-126-964-11	ELECT 10uF	20% 50V	C938	1-126-964-11	ELECT 10uF	20% 50V
C508	1-163-031-11	CERAMIC CHIP 0.01uF	50V	C939	1-163-243-11	CERAMIC CHIP 47PF	5% 50V
C509	1-162-919-11	CERAMIC CHIP 22PF	5% 50V	C940	1-164-004-11	CERAMIC CHIP 0.1uF	10% 25V
C510	1-163-237-11	CERAMIC CHIP 27PF	5% 50V	C941	1-163-001-11	CERAMIC CHIP 220PF	10% 50V
C511	1-163-025-11	CERAMIC CHIP 0.001uF	50V	C942	1-163-243-11	CERAMIC CHIP 47PF	5% 50V
C512	1-163-038-00	CERAMIC CHIP 0.1uF	25V	C943	1-163-243-11	CERAMIC CHIP 47PF	5% 50V
				C945	1-163-243-11	CERAMIC CHIP 47PF	5% 50V

BASE (MAIN)

Ref. No.	Part No.	Description	Remark	Ref. No.	Part No.	Description	Remark
C947	1-163-243-11	CERAMIC CHIP 47PF	5% 50V			< FUSE >	
C948	1-163-243-11	CERAMIC CHIP 47PF	5% 50V				
C950	1-163-243-11	CERAMIC CHIP 47PF	5% 50V	△ F101	1-533-542-11	FUSE (250V/500mA)	
C951	1-164-004-11	CERAMIC CHIP 0.1uF	10% 25V			< IC >	
C952	1-163-235-11	CERAMIC CHIP 22PF	5% 50V				
C953	1-163-989-11	CERAMIC CHIP 0.033uF	10% 25V	IC302	8-759-519-47	IC S-80730AN-DT-T1	
C954	1-163-243-11	CERAMIC CHIP 47PF	5% 50V	IC501	8-759-597-21	IC R6797-71	
				IC502	8-759-487-03	IC S-24C01AFJA-TB-01	
				IC901	8-759-641-04	IC MT88E45	
C956	1-163-243-11	CERAMIC CHIP 47PF	5% 50V				
C957	1-163-243-11	CERAMIC CHIP 47PF	5% 50V	IC902	8-759-510-71	IC BA10358F-E2	
C958	1-163-243-11	CERAMIC CHIP 47PF	5% 50V	IC903	8-759-642-33	IC CMX673P1	
C960	1-164-004-11	CERAMIC CHIP 0.1uF	10% 25V			< JACK >	
C961	1-163-019-00	CERAMIC CHIP 0.0068uF	10% 50V				
				J301	1-779-207-11	JACK,DC(POLARITY UNIFIED TYPE)(DC IN 9V)	
C966	1-163-038-00	CERAMIC CHIP 0.1uF	25V			< JUMPER RESISTOR >	
C967	1-163-009-11	CERAMIC CHIP 0.001uF	10% 50V				
C968	1-163-243-11	CERAMIC CHIP 47PF	5% 50V	JC301	1-216-295-00	SHORT	0
C969	1-162-318-11	CAP, CERAMIC 0.001uF	10% 50V	JC302	1-216-295-00	SHORT	0
C970	1-162-318-11	CAP, CERAMIC 0.001uF	10% 50V	JC501	1-216-864-11	METAL CHIP	0 5% 1/16W
				JC502	1-216-295-00	SHORT	0
C971	1-163-020-00	CERAMIC CHIP 0.0082uF	10% 50V	JC503	1-216-296-00	SHORT	0
C972	1-163-021-11	CERAMIC CHIP 0.01uF	10% 50V				
C973	1-164-346-11	CERAMIC CHIP 1uF	16V	JC504	1-216-296-00	SHORT	0
				JC505	1-216-295-00	SHORT	0
				JC506	1-216-296-00	SHORT	0
				JC507	1-216-296-00	SHORT	0
				JC508	1-216-296-00	SHORT	0
				JC509	1-216-296-00	SHORT	0
				JC510	1-216-296-00	SHORT	0
				JC511	1-216-296-00	SHORT	0
				JC903	1-216-295-00	SHORT	0
				JC904	1-216-295-00	SHORT	0
				JC905	1-216-296-00	SHORT	0
						< COIL >	
				△ L101	1-410-470-11	INDUCTOR	10uH
				△ L102	1-410-470-11	INDUCTOR	10uH
				L110	1-414-722-11	INDUCTOR	12nH
				L111	1-414-282-21	INDUCTOR	2.7nH
				L204	1-414-481-11	INDUCTOR	68nH
				L301	1-410-468-11	INDUCTOR	6.8uH
				L302	1-410-468-11	INDUCTOR	6.8uH
				L303	1-410-468-11	INDUCTOR	6.8uH
				L304	1-410-468-11	INDUCTOR	6.8uH
				L305	1-410-468-11	INDUCTOR	6.8uH
				L501	1-412-945-11	INDUCTOR	3.3uH
				L502	1-411-308-21	INDUCTOR	0uH
				L503	1-414-521-11	INDUCTOR CHIP	10uH
				L504	1-216-821-11	METAL CHIP	1K 5% 1/16W
				L701	1-412-962-11	INDUCTOR	82uH
						< JACK, MODULAR >	
				△ MJ101	1-766-250-11	JACK, MODULAR (2C) 6P (LINE)	
						< PHOTO INTERRUPTER >	
				△ PH101	8-749-923-92	PHOTO COUPLER PS2501L-1-E3	

The components identified by mark △ or dotted line with mark △ are critical for safety. Replace only with part number specified.	Les composants identifiés par une marque △ sont critiques pour la sécurité. Ne les remplacer que par une pièce portant le numéro spécifié.
--	--

BASE (MAIN)

Ref. No.	Part No.	Description	Remark	Ref. No.	Part No.	Description	Remark
△ PH102	8-749-016-30	PHOTP COUPLER PS2533L-1-E3		R508	1-216-097-00	RES,CHIP 100K	5% 1/10W
△ PH901	8-749-016-34	PHOTO COUPLER PS2502L-1-K-E3		R509	1-216-073-00	METAL CHIP 10K	5% 1/10W
		< TRANSISTOR >		R511	1-216-041-00	METAL CHIP 470	5% 1/10W
△ Q101	8-729-032-66	TRANSISTOR 2SC5069-TD		R512	1-216-009-00	RES,CHIP 22	5% 1/10W
Q102	8-729-920-75	TRANSISTOR 2SC2412K-T-146-QR		R513	1-216-864-11	METAL CHIP 0	5% 1/16W
Q103	8-729-920-75	TRANSISTOR 2SC2412K-T-146-QR		R514	1-216-864-11	METAL CHIP 0	5% 1/16W
Q301	8-729-920-75	TRANSISTOR 2SC2412K-T-146-QR		R515	1-216-817-11	METAL CHIP 470	5% 1/16W
Q302	8-729-920-75	TRANSISTOR 2SC2412K-T-146-QR		R516	1-216-057-00	METAL CHIP 2.2K	5% 1/10W
				R517	1-216-121-00	RES,CHIP 1M	5% 1/10W
Q303	8-729-922-26	TRANSISTOR 2SD1758F5-Q		R518	1-216-809-11	METAL CHIP 100	5% 1/16W
Q304	8-729-026-50	TRANSISTOR 2SA1037AK-T146-QR		R520	1-216-295-00	SHORT 0	
Q305	8-729-026-50	TRANSISTOR 2SA1037AK-T146-QR		R521	1-216-041-00	METAL CHIP 470	5% 1/10W
Q306	8-729-920-75	TRANSISTOR 2SC2412K-T-146-QR		R522	1-216-073-00	METAL CHIP 10K	5% 1/10W
Q307	8-729-026-50	TRANSISTOR 2SA1037AK-T146-QR		R523	1-216-833-11	RES,CHIP 10K	5% 1/16W
				R524	1-216-041-00	METAL CHIP 470	5% 1/10W
Q902	8-729-026-50	TRANSISTOR 2SA1037AK-T146-QR		R525	1-216-025-00	METAL CHIP 100	5% 1/10W
Q903	8-729-049-65	TRANSISTOR 2SC5595-T146		R526	1-216-017-00	RES,CHIP 47	5% 1/10W
Q904	8-729-049-65	TRANSISTOR 2SC5595-T146		R527	1-216-041-00	METAL CHIP 470	5% 1/10W
Q905	8-729-049-65	TRANSISTOR 2SC5595-T146		R529	1-216-041-00	METAL CHIP 470	5% 1/10W
Q907	8-729-049-65	TRANSISTOR 2SC5595-T146		R530	1-216-041-00	METAL CHIP 470	5% 1/10W
Q908	8-729-049-65	TRANSISTOR 2SC5595-T146		R531	1-216-817-11	METAL CHIP 470	5% 1/16W
		< RESISTOR >		R532	1-216-073-00	METAL CHIP 10K	5% 1/10W
R101	1-215-861-00	METAL OXIDE 47	5% 1W F	R550	1-216-025-00	RES,CHIP 100	5% 1/10W
R102	1-249-417-11	CARBON 1K	5% 1/4W F	R552	1-216-809-11	METAL CHIP 100	5% 1/16W
R103	1-215-859-00	METAL OXIDE 22	5% 1W F	R553	1-216-025-00	RES,CHIP 100	5% 1/10W
R104	1-216-065-00	RES,CHIP 4.7K	5% 1/10W	R554	1-216-817-11	METAL CHIP 470	5% 1/16W
R105	1-216-065-00	RES,CHIP 4.7K	5% 1/10W	R555	1-216-817-11	METAL CHIP 470	5% 1/16W
				R556	1-216-817-11	METAL CHIP 470	5% 1/16W
R106	1-216-085-00	METAL CHIP 33K	5% 1/10W	R557	1-216-817-11	METAL CHIP 470	5% 1/16W
R107	1-216-073-00	METAL CHIP 10K	5% 1/10W	R558	1-216-025-00	RES,CHIP 100	5% 1/10W
R108	1-215-877-11	METAL OXIDE 22K	5% 1W F	R559	1-216-817-11	METAL CHIP 470	5% 1/16W
R109	1-216-053-00	METAL CHIP 1.5K	5% 1/10W	R560	1-216-041-00	METAL CHIP 470	5% 1/10W
R110	1-216-037-00	METAL CHIP 330	5% 1/10W	R562	1-216-295-00	SHORT 0	
				R701	1-216-833-11	RES,CHIP 10K	5% 1/16W
R301	1-216-069-00	METAL CHIP 6.8K	5% 1/10W	R702	1-216-073-00	METAL CHIP 10K	5% 1/10W
R303	1-216-073-00	METAL CHIP 10K	5% 1/10W	R703	1-216-097-00	RES,CHIP 100K	5% 1/10W
R304	1-216-833-11	RES,CHIP 10K	5% 1/16W	R704	1-216-097-00	RES,CHIP 100K	5% 1/10W
R305	1-216-089-00	RES,CHIP 47K	5% 1/10W	R705	1-216-057-00	METAL CHIP 2.2K	5% 1/10W
R306	1-249-391-11	CARBON 6.8	5% 1/4W F	R706	1-216-039-00	METAL CHIP 390	5% 1/10W
				R707	1-216-039-00	METAL CHIP 390	5% 1/10W
R307	1-249-392-11	CARBON 8.2	5% 1/4W F	R901	1-216-121-00	RES,CHIP 1M	5% 1/10W
R308	1-249-397-11	CARBON 22	5% 1/4W	R903	1-216-081-00	METAL CHIP 22K	5% 1/10W
R309	1-216-101-00	METAL CHIP 150K	5% 1/10W	R905	1-216-093-11	RES,CHIP 68K	5% 1/10W
R310	1-216-105-00	RES,CHIP 220K	5% 1/10W	R906	1-216-295-00	SHORT 0	
R311	1-216-097-00	RES,CHIP 100K	5% 1/10W	R907	1-216-117-00	METAL CHIP 680K	5% 1/10W
				R908	1-216-097-00	RES,CHIP 100K	5% 1/10W
R312	1-216-097-00	RES,CHIP 100K	5% 1/10W	R909	1-216-097-00	RES,CHIP 100K	5% 1/10W
R313	1-216-057-00	METAL CHIP 2.2K	5% 1/10W	R910	1-216-117-00	METAL CHIP 680K	5% 1/10W
R314	1-216-033-00	METAL CHIP 220	5% 1/10W	R912	1-216-121-00	RES,CHIP 1M	5% 1/10W
R315	1-260-089-11	CARBON 150	5% 1/2W	R913	1-216-121-00	RES,CHIP 1M	5% 1/10W
R316	1-216-073-00	METAL CHIP 10K	5% 1/10W	R919	1-216-013-00	METAL CHIP 33	5% 1/10W
				R920	1-216-073-00	METAL CHIP 10K	5% 1/10W
R318	1-215-859-00	METAL OXIDE 22	5% 1W F	R921	1-216-033-00	METAL CHIP 220	5% 1/10W
R319	1-215-861-00	METAL OXIDE 47	5% 1W F	R922	1-216-077-00	RES,CHIP 15K	5% 1/10W
R320	1-216-109-00	METAL CHIP 330K	5% 1/10W	R923	1-216-073-00	METAL CHIP 10K	5% 1/10W
R321	1-216-105-00	RES,CHIP 220K	5% 1/10W	R924	1-216-041-00	METAL CHIP 470	5% 1/10W
R501	1-216-295-00	SHORT 0					
R502	1-216-041-00	METAL CHIP 470	5% 1/10W				
R503	1-216-041-00	METAL CHIP 470	5% 1/10W				
R504	1-216-041-00	METAL CHIP 470	5% 1/10W				
R505	1-216-041-00	METAL CHIP 470	5% 1/10W				
R507	1-216-041-00	METAL CHIP 470	5% 1/10W				

The components identified by mark △ or dotted line with mark △ are critical for safety. Replace only with part number specified.	Les composants identifiés par une marque △ sont critiques pour la sécurité. Ne les remplacer que par une pièce portant le numéro spécifié.
--	--

BASE (MAIN)

HAND (MAIN)

Ref. No.	Part No.	Description	Remark
R925	1-216-105-00	RES,CHIP 220K 5%	1/10W
R926	1-216-085-00	METAL CHIP 33K 5%	1/10W
R927	1-216-295-00	SHORT 0	
R928	1-216-097-00	RES,CHIP 100K 5%	1/10W
R929	1-216-667-11	METAL CHIP 4.7K 0.50%	1/10W
R930	1-216-681-11	METAL CHIP 18K 0.50%	1/10W
R931	1-216-667-11	METAL CHIP 4.7K 0.50%	1/10W
R932	1-216-109-00	METAL CHIP 330K 5%	1/10W
R934	1-216-057-00	METAL CHIP 2.2K 5%	1/10W
R935	1-216-025-00	RES,CHIP 100 5%	1/10W
R936	1-216-113-00	METAL CHIP 470K 5%	1/10W
R937	1-216-113-00	METAL CHIP 470K 5%	1/10W
R938	1-216-049-00	RES,CHIP 1K 5%	1/10W
R939	1-216-295-00	SHORT 0	
R942	1-216-077-00	RES,CHIP 15K 5%	1/10W
R943	1-216-109-00	METAL CHIP 330K 5%	1/10W
R944	1-216-025-00	RES,CHIP 100 5%	1/10W
R945	1-216-065-00	RES,CHIP 4.7K 5%	1/10W
R946	1-216-049-11	RES,CHIP 1K 5%	1/10W
R947	1-216-105-00	RES,CHIP 220K 5%	1/10W
R948	1-216-101-00	METAL CHIP 150K 5%	1/10W
R949	1-216-089-00	RES,CHIP 47K 5%	1/10W
R950	1-216-085-00	METAL CHIP 33K 5%	1/10W
R951	1-216-081-00	METAL CHIP 22K 5%	1/10W
R952	1-216-117-00	METAL CHIP 680K 5%	1/10W
R953	1-216-129-00	METAL CHIP 2.2M 5%	1/10W
R954	1-216-129-00	METAL CHIP 2.2M 5%	1/10W
R955	1-216-121-00	RES,CHIP 1M 5%	1/10W
R956	1-216-295-00	SHORT 0	
R960	1-216-295-00	SHORT 0	
R962	1-216-295-00	SHORT 0	
R966	1-216-009-00	RES,CHIP 22 5%	1/10W
R967	1-216-295-00	SHORT 0	
R968	1-216-089-00	RES,CHIP 47K 5%	1/10W
R975	1-216-073-00	METAL CHIP 10K 5%	1/10W
R976	1-216-105-00	RES,CHIP 220K 5%	1/10W
< MODULATOR >			
RFU801	1-418-269-11	RF UNIT	
< SPARK GAP >			
△SG101	1-533-751-11	ABSORBER, SURGE	
< SWITCH >			
SW501	1-692-991-11	SWITCH, SLIDE (DIAL MODE)	
< TRANSFORMER >			
△T101	1-431-832-11	TRANSFORMER, LINE	
< VIBRATOR >			
X501	1-767-566-31	VIBRATOR, CRYSTAL (9.6MHz)	
X901	1-781-538-11	VIBRATOR, CRYSTAL (3.579545MHz)	

Ref. No.	Part No.	Description	Remark
*	A-3622-339-A	HAND (MAIN) BOARD, COMPLETE	*****
	3-034-819-01	TERMINAL (H BATTERY), CHARGE	
< BUZZER >			
BZ601	1-544-603-11	BUZZER	
< CAPACITOR >			
C201	1-163-025-11	CERAMIC CHIP 0.001uF	50V
C202	1-126-206-11	ELECT CHIP 100uF	20% 6.3V
C203	1-163-031-11	CERAMIC CHIP 0.01uF	50V
C204	1-163-235-11	CERAMIC CHIP 22PF	5% 50V
C205	1-163-031-11	CERAMIC CHIP 0.01uF	50V
C206	1-164-005-11	CERAMIC CHIP 0.47uF	25V
C207	1-163-033-00	CERAMIC CHIP 0.022uF	50V
C208	1-163-251-11	CERAMIC CHIP 100PF	5% 50V
C209	1-163-033-00	CERAMIC CHIP 0.022uF	50V
C210	1-163-033-00	CERAMIC CHIP 0.022uF	50V
C211	1-163-038-00	CERAMIC CHIP 0.1uF	25V
C212	1-163-125-00	CAP, CERAMIC CHIP 220PF	5% 50V
C401	1-163-038-00	CERAMIC CHIP 0.1uF	25V
C402	1-163-031-11	CERAMIC CHIP 0.01uF	50V
C403	1-164-360-11	CERAMIC CHIP 0.1uF	16V
C404	1-163-235-11	CERAMIC CHIP 22PF	5% 50V
C405	1-117-370-11	CERAMIC CHIP 10uF	10V
C406	1-164-360-11	CERAMIC CHIP 0.1uF	16V
C407	1-163-235-11	CERAMIC CHIP 22PF	5% 50V
C408	1-163-235-11	CERAMIC CHIP 22PF	5% 50V
C409	1-162-974-11	CERAMIC CHIP 0.01uF	50V
C410	1-163-031-11	CERAMIC CHIP 0.01uF	50V
C411	1-164-360-11	CERAMIC CHIP 0.1uF	16V
C412	1-164-360-11	CERAMIC CHIP 0.1uF	16V
C413	1-126-246-11	ELECT CHIP 220uF	20% 4V
C414	1-117-370-11	CERAMIC CHIP 10uF	10V
C415	1-126-603-11	ELECT CHIP 4.7uF	20% 35V
C416	1-163-035-00	CERAMIC CHIP 0.047uF	50V
C417	1-126-603-11	ELECT CHIP 4.7uF	20% 35V
C418	1-164-360-11	CERAMIC CHIP 0.1uF	16V
C419	1-164-360-11	CERAMIC CHIP 0.1uF	16V
C420	1-117-370-11	CERAMIC CHIP 10uF	10V
C421	1-164-360-11	CERAMIC CHIP 0.1uF	16V
C422	1-163-038-00	CERAMIC CHIP 0.1uF	25V
C423	1-164-360-11	CERAMIC CHIP 0.1uF	16V
C424	1-162-915-11	CERAMIC CHIP 10PF	0.5PF 50V
C425	1-164-360-11	CERAMIC CHIP 0.1uF	16V
C601	1-163-031-11	CERAMIC CHIP 0.01uF	50V
C605	1-110-501-11	CERAMIC CHIP 0.33uF	10% 16V
C606	1-115-565-11	CERAMIC CHIP 2.2uF	10% 10V
C613	1-163-020-00	CERAMIC CHIP 0.0082uF	10% 50V
C614	1-163-020-00	CERAMIC CHIP 0.0082uF	10% 50V
C616	1-163-243-11	CERAMIC CHIP 47PF	5% 50V
C617	1-117-370-11	CERAMIC CHIP 10uF	10V
C619	1-163-235-11	CERAMIC CHIP 22PF	5% 50V
C620	1-163-239-11	CERAMIC CHIP 33PF	5% 50V
C621	1-110-501-11	CERAMIC CHIP 0.33uF	10% 16V

The components identified by mark △ or dotted line with mark △ are critical for safety. Replace only with part number specified.	Les composants identifiés par une marque △ sont critiques pour la sécurité. Ne les remplacer que par une pièce portant le numéro spécifié.
--	--

Ref. No.	Part No.	Description	Remark	Ref. No.	Part No.	Description	Remark
C622	1-163-239-11	CERAMIC CHIP 33PF	5% 50V			< COIL >	
C624	1-163-169-00	CERAMIC CHIP 33PF	5% 50V				
C625	1-117-370-11	CERAMIC CHIP 10uF	10V	L201	1-412-945-11	INDUCTOR 3.3uH	
C627	1-117-370-11	CERAMIC CHIP 10uF	10V	L202	1-216-296-00	SHORT 0	
C801	1-163-038-00	CERAMIC CHIP 0.1uF	25V	L203	1-216-296-00	SHORT 0	
C802	1-163-139-00	CERAMIC CHIP 820PF	5% 50V	L204	1-410-379-21	INDUCTOR CHIP 6.8uH	
C805	1-163-038-00	CERAMIC CHIP 0.1uF	25V	L205	1-410-379-21	INDUCTOR CHIP 6.8uH	
C806	1-163-038-00	CERAMIC CHIP 0.1uF	25V	L206	1-410-379-21	INDUCTOR CHIP 6.8uH	
C807	1-163-038-00	CERAMIC CHIP 0.1uF	25V	L207	1-410-379-21	INDUCTOR CHIP 6.8uH	
C808	1-163-235-11	CERAMIC CHIP 22PF	5% 50V	L401	1-216-823-11	METAL CHIP 1.5K	5% 1/16W
C809	1-163-235-11	CERAMIC CHIP 22PF	5% 50V	L402	1-414-528-11	INDUCTOR 56nH	
		< CONNECTOR >		L402	1-414-730-21	INDUCTOR 56nH	
* CN202	1-766-809-11	PIN, CONNECTOR (PC BOARD) 3P		L601	1-414-481-11	INDUCTOR 68nH	
CN401	1-568-237-11	CONNECTOR, FPC (1.0MM)(ZIF)14P		L602	1-414-481-11	INDUCTOR 68nH	
CN601	1-770-359-11	PIN, CONNECTOR (PC BOARD) 2P		L801	1-412-962-11	INDUCTOR 82uH	
		< DIODE >		L803	1-414-285-11	INDUCTOR 4.7nH	
D201	8-719-938-75	DIODE SB05-05CP-TB				< MICROPHONE >	
D202	8-719-981-56	DIODE SB05W05C-TB		MIC601	1-542-118-11	MICROPHONE, ELECTRET CONDENSER	
D203	8-719-938-75	DIODE SB05-05CP-TB				< TRANSISTOR >	
D205	8-719-914-43	DIODE DAN202K-T-146		Q201	8-729-920-75	TRANSISTOR 2SC2412K-T-146-QR	
D206	8-719-066-61	DIODE RD5.6P-T1		Q202	8-729-026-50	TRANSISTOR 2SA1037AK-T146-QR	
D207	8-719-914-42	DIODE DA204K-T-146		Q203	8-729-920-75	TRANSISTOR 2SC2412K-T-146-QR	
D208	8-719-066-61	DIODE RD5.6P-T1		Q204	8-729-026-50	TRANSISTOR 2SA1037AK-T146-QR	
D209	8-719-914-42	DIODE DA204K-T-146		Q402	8-729-026-50	TRANSISTOR 2SA1037AK-T146-QR	
D401	8-719-158-15	DIODE RD5.6SB-T1		Q404	8-729-026-50	TRANSISTOR 2SA1037AK-T146-QR	
D404	8-719-075-88	DIODE PY1112H-630-TR (ILLUMINATION)		Q405	8-729-026-50	TRANSISTOR 2SA1037AK-T146-QR	
D405	8-719-075-88	DIODE PY1112H-630-TR (ILLUMINATION)		Q601	8-729-920-75	TRANSISTOR 2SC2412K-T-146-QR	
D406	8-719-075-88	DIODE PY1112H-630-TR (ILLUMINATION)				< RESISTOR >	
D407	8-719-075-88	DIODE PY1112H-630-TR (ILLUMINATION)		R201	1-216-296-00	SHORT 0	
D408	8-719-076-57	DIODE PY1102W-350-TR		R203	1-216-093-00	RES,CHIP 68K	5% 1/10W
D409	8-719-076-57	DIODE PY1102W-350-TR		R204	1-216-085-00	METAL CHIP 33K	5% 1/10W
D410	8-719-988-61	DIODE 1SS355TE-17		R205	1-216-097-00	RES,CHIP 100K	5% 1/10W
D411	8-719-914-42	DIODE DA204K-T-146		R206	1-216-069-00	METAL CHIP 6.8K	5% 1/10W
D412	8-719-914-42	DIODE DA204K-T-146		R207	1-216-089-00	RES,CHIP 47K	5% 1/10W
D413	8-719-158-15	DIODE RD5.6SB-T1		R208	1-216-073-00	METAL CHIP 10K	5% 1/10W
D414	8-719-914-43	DIODE DAN202K-T-146		R209	1-216-049-11	RES,CHIP 1K	5% 1/10W
D415	8-719-914-43	DIODE DAN202K-T-146		R210	1-216-097-00	RES,CHIP 100K	5% 1/10W
D416	8-719-988-61	DIODE 1SS355TE-17		R211	1-216-089-00	RES,CHIP 47K	5% 1/10W
D417	8-719-988-61	DIODE 1SS355TE-17		R212	1-216-073-00	METAL CHIP 10K	5% 1/10W
D418	8-719-988-61	DIODE 1SS355TE-17		R213	1-216-073-00	METAL CHIP 10K	5% 1/10W
D419	8-719-988-61	DIODE 1SS355TE-17		R214	1-216-097-00	RES,CHIP 100K	5% 1/10W
D421	8-719-076-57	DIODE PY1102W-350-TR		R215	1-216-298-00	METAL CHIP 2.2	5% 1/10W
D422	8-719-158-15	DIODE RD5.6SB-T1		R216	1-216-073-00	METAL CHIP 10K	5% 1/10W
D423	8-719-158-15	DIODE RD5.6SB-T1		R401	1-216-296-00	SHORT 0	
D601	8-719-914-42	DIODE DA204K-T-146		R402	1-216-296-00	SHORT 0	
D801	8-719-158-15	DIODE RD5.6SB-T1		R403	1-412-995-21	INDUCTOR 22uH	
		< IC >		R404	1-216-073-00	METAL CHIP 10K	5% 1/10W
IC201	8-759-519-47	IC S-80730AN-DT-T1		R405	1-216-049-11	METAL CHIP 1K	5% 1/10W
IC401	8-759-597-21	IC R6797-71		R408	1-216-033-00	METAL CHIP 220	5% 1/10W
IC402	8-759-392-92	IC AT24C32N-10SI-1.8-TR		R409	1-216-033-00	METAL CHIP 220	5% 1/10W
IC403	8-759-523-96	IC TC74VHC86FT(EL)		R410	1-216-033-00	METAL CHIP 220	5% 1/10W
				R411	1-216-033-00	METAL CHIP 220	5% 1/10W
				R412	1-216-025-00	RES,CHIP 100	5% 1/10W
				R413	1-216-025-00	RES,CHIP 100	5% 1/10W

HAND (MAIN)	LED
--------------------	------------

Ref. No.	Part No.	Description	Remark
R414	1-216-073-00	METAL CHIP 10K 5%	1/10W
R415	1-216-817-11	METAL CHIP 470 5%	1/16W
R416	1-216-817-11	METAL CHIP 470 5%	1/16W
R417	1-216-097-00	RES,CHIP 100K 5%	1/10W
R418	1-216-693-11	METAL CHIP 56K 0.5%	1/10W
R419	1-218-735-11	METAL CHIP 62K 0.5%	1/16W
R420	1-216-817-11	METAL CHIP 470 5%	1/16W
R421	1-216-295-00	SHORT 0	
R422	1-216-817-11	METAL CHIP 470 5%	1/16W
R423	1-216-817-11	METAL CHIP 470 5%	1/16W
R424	1-216-097-00	RES,CHIP 100K 5%	1/10W
R425	1-216-097-00	RES,CHIP 100K 5%	1/10W
R426	1-216-817-11	METAL CHIP 470 5%	1/16W
R428	1-216-809-11	METAL CHIP 100 5%	1/16W
R429	1-216-805-11	METAL CHIP 47 5%	1/16W
R430	1-216-817-11	METAL CHIP 470 5%	1/16W
R431	1-216-864-11	METAL CHIP 0 5%	1/16W
R432	1-216-864-11	METAL CHIP 0 5%	1/16W
R434	1-216-817-11	METAL CHIP 470 5%	1/16W
R435	1-216-121-00	RES,CHIP 1M 5%	1/10W
R436	1-216-025-00	RES,CHIP 100 5%	1/10W
R437	1-216-097-00	RES,CHIP 100K 5%	1/10W
R438	1-216-864-11	METAL CHIP 0 5%	1/16W
R439	1-216-864-11	METAL CHIP 0 5%	1/16W
R440	1-216-097-00	RES,CHIP 100K 5%	1/10W
R441	1-216-001-00	METAL CHIP 10 5%	1/10W
R443	1-216-819-11	METAL CHIP 680 5%	1/16W
R444	1-216-065-00	RES,CHIP 4.7K 5%	1/10W
R445	1-216-097-00	RES,CHIP 100K 5%	1/10W
R446	1-216-057-00	METAL CHIP 2.2K 5%	1/10W
R447	1-216-061-00	METAL CHIP 3.3K 5%	1/10W
R448	1-216-295-00	SHORT 0	
R449	1-216-295-00	SHORT 0	
R450	1-216-073-00	METAL CHIP 10K 5%	1/10W
R451	1-216-049-11	METAL CHIP 1K 5%	1/10W
R452	1-216-295-91	SHORT 0	
R453	1-216-295-00	SHORT 0	
R454	1-216-097-00	RES,CHIP 100K 5%	1/10W
R455	1-216-045-00	METAL CHIP 680 5%	1/10W
R457	1-216-025-00	RES,CHIP 100 5%	1/10W
R601	1-216-097-00	RES,CHIP 100K 5%	1/10W
R602	1-216-065-00	METAL CHIP 4.7K 5%	1/10W
R603	1-216-033-00	METAL CHIP 220 5%	1/10W
R605	1-216-045-00	METAL CHIP 680 5%	1/10W
R606	1-216-037-00	METAL CHIP 330 5%	1/10W
R607	1-216-009-00	RES,CHIP 22 5%	1/10W
R618	1-216-017-00	RES,CHIP 47 5%	1/10W
R619	1-216-017-00	RES,CHIP 47 5%	1/10W
R620	1-216-057-00	METAL CHIP 2.2K 5%	1/10W
R621	1-216-017-00	RES,CHIP 47 5%	1/10W
R622	1-216-017-00	RES,CHIP 47 5%	1/10W
R623	1-216-057-00	METAL CHIP 2.2K 5%	1/10W
R624	1-216-295-00	SHORT 0	
R625	1-216-295-00	SHORT 0	
R631	1-216-045-00	METAL CHIP 680 5%	1/10W
R805	1-216-057-00	METAL CHIP 2.2K 5%	1/10W
R806	1-216-039-00	METAL CHIP 390 5%	1/10W

Ref. No.	Part No.	Description	Remark
R807	1-216-039-00	METAL CHIP 390 5%	1/10W
		< MODULATOR >	
RFU801	1-418-269-11	RF UNIT	
		< SWITCH >	
S401	1-762-636-11	SWITCH, SLIDE (RINGER)	
S402	1-475-568-12	ENCODER, ROTARY (JOG DIAL)	
S601	1-771-761-11	SWITCH, SLIDE (VOLUME)	
		< VIBRATOR >	
X401	1-767-566-31	VIBRATOR, CRYSTAL (9.6MHz)	

*	1-674-890-11	LED BOARD	

		< CONNECTOR >	
CN502	1-506-990-11	PIN, CONNECTOR (PC BOARD) 8P	
		< DIODE >	
D571	8-719-059-87	DIODE SLR-342VRTB7 (NEW CALL)	
D572	8-719-059-87	DIODE SLR-342VRTB7 (MESSAGE)	
D573	8-719-059-87	DIODE SLR-342VRTB7 (SPARE BATTERY)	
D574	8-719-059-87	DIODE SLR-342VRTB7 (CHARGE)	
		< JUMPER RESISTOR >	
JC574	1-216-295-00	SHORT 0	
		< TRANSISTOR >	
Q571	8-729-026-50	TRANSISTOR 2SA1037AK-T146-QR	
Q572	8-729-026-50	TRANSISTOR 2SA1037AK-T146-QR	
		< RESISTOR >	
R572	1-216-025-00	RES,CHIP 100 5%	1/10W
R573	1-216-025-00	RES,CHIP 100 5%	1/10W
R574	1-216-041-00	METAL CHIP 470 5%	1/10W
R576	1-216-025-00	RES,CHIP 100 5%	1/10W
R577	1-216-025-00	RES,CHIP 100 5%	1/10W
R578	1-216-041-00	METAL CHIP 470 5%	1/10W
R580	1-216-041-00	METAL CHIP 470 5%	1/10W
R581	1-216-041-00	METAL CHIP 470 5%	1/10W
		< SWITCH >	
SW571	1-571-977-11	SWITCH, TACTIL (PAGE)	

		MISCELLANEOUS	

7	1-771-616-11	SWITCH, RUBBER KEY	
ANT1	1-754-054-11	ANTENNA	
ANT701	3-038-540-01	TERMINAL, ANTENNA	
LCD401	1-418-604-11	LCD UNIT	
SP601	1-505-695-11	SPEAKER (2.1CM)	

Ref. No.	Part No.	Description	Remark
	ACCESSORIES & PACKING MATERIALS		

△	1-475-780-31	ADAPTOR, AC (AC-T123)	
	1-528-976-11	BATTERY, NI-CD (BP-T31)	
	1-696-453-21	CORD (WITH MODULAR PLUG)(LINE)(22 cm)	
	1-696-454-11	CORD (WITH MODULAR PLUG)(LINE)(2m 15 cm)	
	3-012-379-31	WALL BRACKET	
	3-866-975-11	MANUAL,INSTRUCTION (US)(ENGLISH, SPANISH)	
	3-866-975-21	MANUAL,INSTRUCTION (CND)(ENGLISH, FRENCH)	
	3-866-976-11	GUIDE, QUICK START (US)(ENGLISH, SPANISH)	
	3-866-976-21	GUIDE, QUICK START (CND)(ENGLISH, FRENCH)	
	3-936-680-01	LABEL (ADDRESS)	

	HARDWARE LIST		

#1	7-685-134-19	SCREW +BTP 2.6X8 TYPE2 N-S	
#2	7-685-136-19	SCREW +BTP 2.6X12 TYPE2 N-S	
#3	7-685-647-79	SCREW +P 3X10 TYPE2 NON-SLIT	
#4	7-685-133-19	SCREW +BTP 2.6X6 TYPE2 N-S	

The components identified by mark △ or dotted line with mark △ are critical for safety. Replace only with part number specified.	Les composants identifiés par une marque △ sont critiques pour la sécurité. Ne les remplacer que par une pièce portant le numéro spécifié.
--	--

