

SPP-SS965

SERVICE MANUAL

*US Model
Canadian Model*



SPECIFICATIONS

General

Spread method
Direct-Sequence Spread-Spectrum
Access method
FDMA-TDD
Operation frequency
902-928 MHz (100 mW)
Operating channel
20 channels
Dial signal
Tone, 10 PPS (pulse) selectable
Supplied accessories
AC power adaptor (AC-T46)
Telephone line cords (2)
Wall bracket/stand for base phone
Rechargeable battery pack (BP-T24)
Directories

Handset

Power source
Rechargeable battery pack BP-T24
Battery life
Standby: Approx. 10 days (RING ON mode)
Approx. A month (RING OFF mode)
Talk: Approx. 6 hours
Dimensions
Approx. 58 x 177 x 46 mm (w / h / d),
antenna excluded
(approx. 2 ³/₈ x 7 x 1 ¹³/₁₆ inches)
Antenna: Approx. 72 mm
(approx. 2 ⁷/₈ inches)
Mass
Approx. 250 g
(approx. 8.8 oz), battery included

Base phone

Power source
DC 9V from AC power adaptor
AC-T46
Battery charging time
Approx. 12 hours
Dimensions
Approx. 170 x 60 x 214 mm (w / h / d),
antenna excluded
(approx. 6 ³/₄ x 2 ³/₈ x 8 ¹/₂ inches)
Antenna: Approx. 165 mm
(approx. 6 ¹/₂ inches)
Mass
Approx. 580 g
(approx. 1 lb 4 oz), wall bracket excluded

Design and specifications are subject to
change without notice.

CORDLESS TELEPHONE

SONY®



TABLE OF CONTENTS

1. SERVICING NOTES	3
2. GENERAL	
Setting Up the Base Phone	4
Preparing the Battery Pack	4
Entering Your Area Code	5
Making Calls	5
Receiving Calls	6
One-Touch Dialing	6
Speed Dialing	7
Phone Directory	7
Switching the Phones During a Call	8
Talking between the Phones (Intercom)	9
Voice Paging	9
Transferring a Call	9
Understanding the Caller ID Service	10
Looking at the Caller ID List	10
Using the Caller ID List	11
Using "Caller ID with Visual Call Waiting" Service	11
3. DISASSEMBLY	12
4. 900 MHz SYSTEM OPERATION	
4-1. Access Method	15
4-2. Protocol	15
5. TEST MODE	
5-1. Base Unit	18
5-2. Handset	19
5-3. RF Testing	20
6. ELECTRICAL ADJUSTMENTS	
6-1. Base Unit Section	22
6-2. Handset Section	23
7. DIAGRAMS	
7-1. Block Diagram – BASE UNIT Section (1/2) –	27
7-2. Block Diagram – BASE UNIT Section (2/2) –	29
7-3. Block Diagram – HANDSET Section –	31
7-4. Notes for Printed Wiring Boards and Schematic Diagrams	33
7-5. Printed Wiring Boards – BASE MAIN Board (Side A)/ BASE MICROPHONE Board –	35
7-6. Printed Wiring Board – BASE MAIN Board (Side B) –	37
7-7. Schematic Diagram – BASE MAIN Section (1/3) –	39
7-8. Schematic Diagram – BASE MAIN Section (2/3) –	41
7-9. Schematic Diagram – BASE MAIN Section (3/3) –	43
7-10. Printed Wiring Board – BASE KEY Section –	45
7-11. Schematic Diagram – BASE KEY Section –	46
7-12. Printed Wiring Board – BASE LCD Section –	47
7-13. Schematic Diagram – BASE LCD Section –	48
7-14. Printed Wiring Board – HAND MAIN Section –	49
7-15. Schematic Diagram – HAND MAIN Section –	51
7-16. IC Pin Function Description	55
8. EXPLODED VIEWS	61
9. ELECTRICAL PARTS LIST	63

Notes on chip component replacement

- Never reuse a disconnected chip component.
- Notice that the minus side of a tantalum capacitor may be damaged by heat.

SAFETY-RELATED COMPONENT WARNING!!

COMPONENTS IDENTIFIED BY MARK \triangle OR DOTTED LINE WITH MARK \triangle ON THE SCHEMATIC DIAGRAMS AND IN THE PARTS LIST ARE CRITICAL TO SAFE OPERATION. REPLACE THESE COMPONENTS WITH SONY PARTS WHOSE PART NUMBERS APPEAR AS SHOWN IN THIS MANUAL OR IN SUPPLEMENTS PUBLISHED BY SONY.

ATTENTION AU COMPOSANT AYANT RAPPORT À LA SÉCURITÉ!

LES COMPOSANTS IDENTIFIÉS PAR UNE MARQUE \triangle SUR LES DIAGRAMMES SCHÉMATIQUES ET LA LISTE DES PIÈCES SONT CRITIQUES POUR LA SÉCURITÉ DE FONCTIONNEMENT. NE REMPLACER CES COMPOSANTS QUE PAR DES PIÈCES SONY DONT LES NUMÉROS SONT DONNÉS DANS CE MANUEL OU DANS LES SUPPLÉMENTS PUBLIÉS PAR SONY.

SECTION 1 SERVICING NOTES

CABLE FASTENING METHOD

- TDD noise may be generated in the intercom or handset speech depending on how the cables are fastened, and therefore fasten the cables as shown below.

- ① Erect the cabinet (upper) 90 degrees.
- ② Insert the wires in the ribs at **A** and **B**.
- ③ Clamp them at **C** to **E**.
- ④ Affix the sponges at **F** positions.
- ⑤ Fix the cables with tapes at **G** to **L** positions.

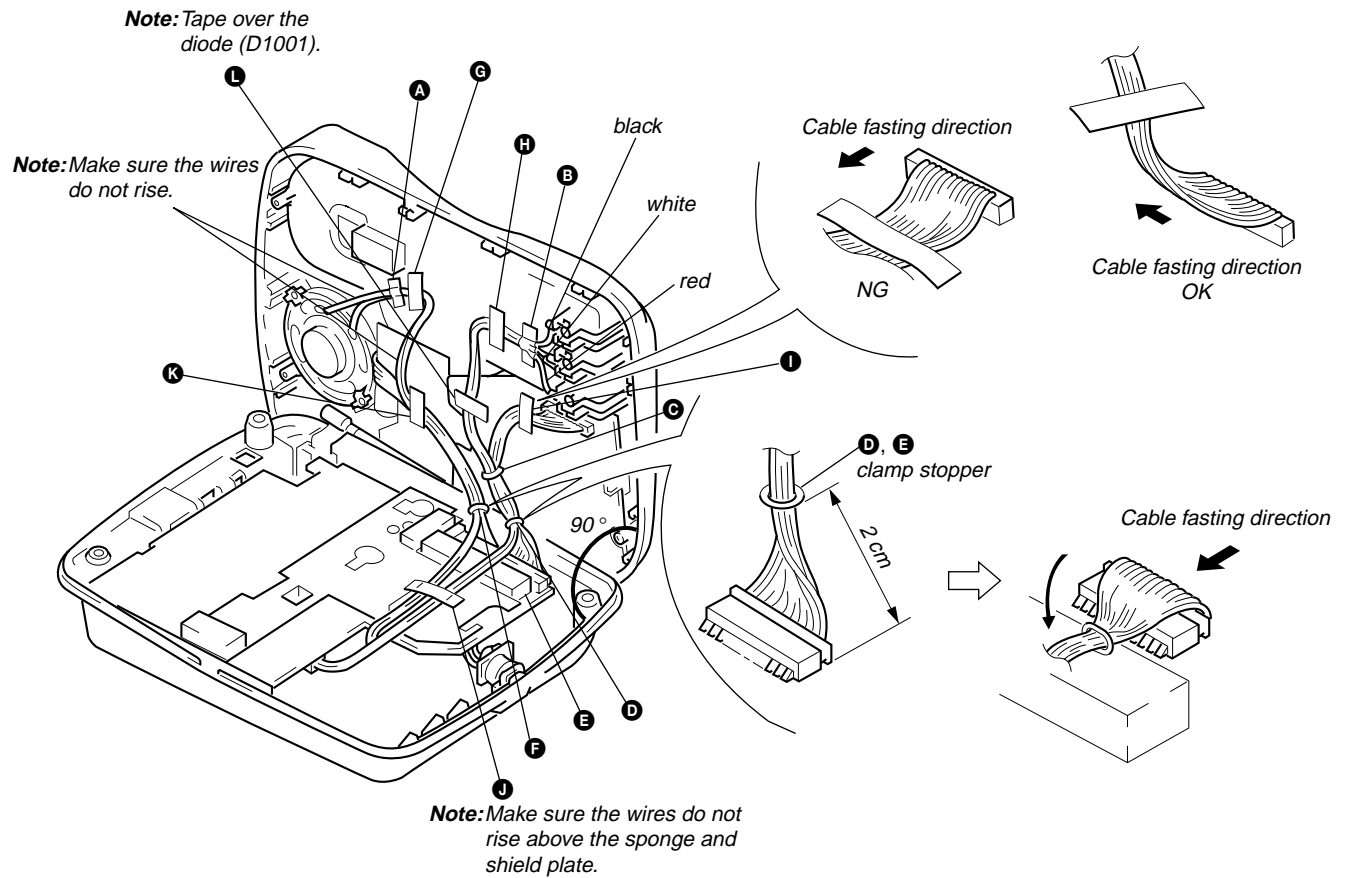

Step 2

Setting up the base phone

Do the following steps:

- Choose the best location
- Connect the base phone
- Choose the dialing mode

Choose the best location

Where you place the base phone affects the reception quality of the handset.

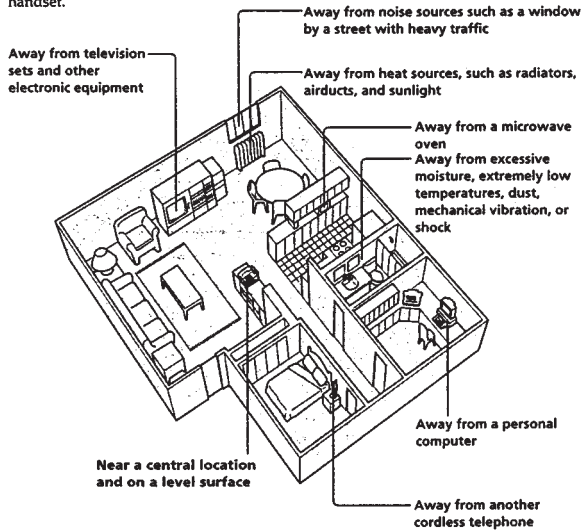

CAUTION: • Should you experience intermittent loss of audio during a conversation, try moving closer to the base or move base phone away from other noise sources.
• The cordless telephone operates at a frequency that may cause interference to nearby TVs and VCRs; the base phone should not be placed near or on the top of a TV or VCR; and, if interference is experienced, moving the cordless telephone farther away from the TV or VCR will often reduce or eliminate the interference.

Connect the base phone

If you want to hang the base phone on the wall, see page 38.

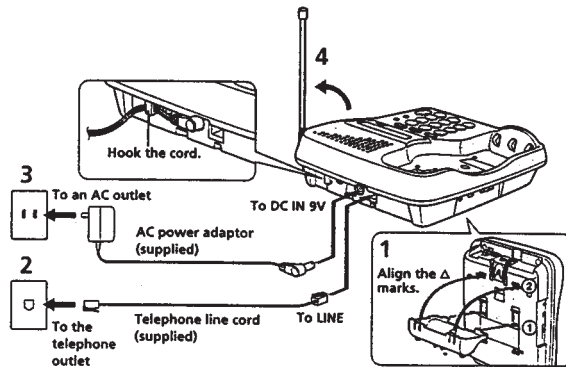

- 1 Attach the wall bracket to the bottom of the base phone as illustrated to use it as a stand.
- 2 Connect the telephone line cord to the LINE jack and to a telephone outlet.
- 3 Connect the AC power adaptor to the DC IN 9V jack and to an AC outlet.
- 4 Raise the antenna. Make sure it points towards the ceiling.

Getting Started

6th Getting Started

continued
Getting Started 7th

Step 2: Setting up the base phone (continued)

Notes

- Use only the supplied AC-T46 AC power adaptor. Do not use any other AC power adaptor.
- Connect the AC power adaptor to a continuous power supply.
- Place the base phone close to the AC outlet so that you can unplug the AC power adaptor easily.

Polarity of the plug



Tips

- If your telephone outlet isn't modular, contact your telephone service company for assistance.
- To remove the wall bracket, press in the upper tab.

Modular



Choose the dialing mode

For the telephone to work properly, select an appropriate dialing mode (tone or pulse).

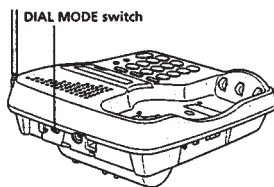

Depending on your dialing system, set the DIAL MODE switch as follows:

If your dialing system is	Set the switch to
Tone	T
Pulse	P

If you aren't sure of your dialing system

Make a trial call with the DIAL MODE switch set to T. If the call connects, leave the switch as is; otherwise, set to P.

Step 3

Preparing the battery pack

Charge the battery pack for more than 12 hours before you start using your phone.

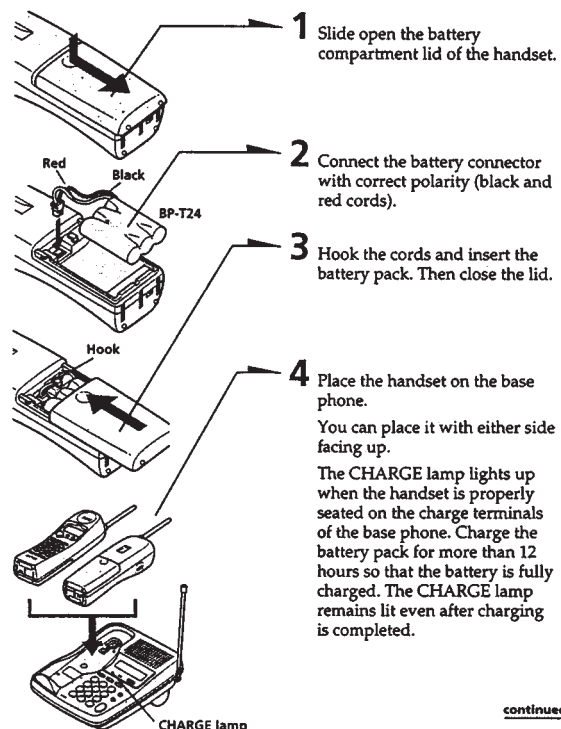

Getting Started

continued

8th Getting Started

Getting Started 9th

Step 3: Preparing the battery pack (continued)**Battery duration**

A fully charged battery pack lasts for about:

- 6 hours when you use the handset continuously
- 10 days (RING ON mode) or a month (RING OFF mode) when the handset is in standby mode.

Notes

- The battery pack will gradually discharge over a long period of time, even when not in use.
- To obtain the best handset performance, place the handset on the base phone for charging after several calls.
- If you leave the battery pack in the handset without charging it, the battery pack will be completely discharged. It may require several times of charging to recover to its full capacity.
- While charging, the battery pack warms up. This is not a malfunction.

When to purchase a new battery pack

If the battery lasts only a few minutes even after 12 hours of charging, the usable life of the battery has expired and needs replacement. Contact your local Sony authorized dealer or service center, and ask for a Sony BP-T24 rechargeable battery pack.

Note

Battery life may vary depending on usage condition and ambient temperature.

Step 4**Entering your area code**

When you use this phone for the first time, or move to an area that has a different area code, you must enter your area code.

This is necessary because the phone must be able to distinguish between local or long distance calls to properly dial calls from the Caller ID list.

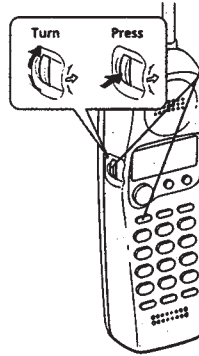

- 1 Press **(VOL/PGM)**.
- 2 Turn Jog Dial up to make "AREA" flash.

- 3 Press Jog Dial.
"ENTER AREA CODE" appears on the display.
- 4 Enter your three digits area code using the dialing keys.
- 5 Press **(VOL/PGM)**.
You'll hear a long confirmation beep.

Notes

- If an area code is already entered, it appears on the display in step 3. To enter a different area code, see "To change the area code" below.
- Do not allow more than 20 seconds to elapse between each step of the procedure.

Tips

- You may press Jog Dial instead of **(VOL/PGM)** in step 5.
- To check the current area code, perform steps 1 to 3 above. The area code appears on the display for 20 seconds.

To change the area code

- 1 Perform steps 1 to 3 above.

The current area code appears on the display.

- 2 Turn Jog Dial down to erase the current area code.
- 3 Enter a new area code using the dialing keys.
- 4 Press **(VOL/PGM)**.

You'll hear a long confirmation beep.

Basics**Making calls**

- 1 Pick up the handset from the base phone.
- 2 Press **(TALK/ CALL WAITING/ FLASH)** and wait until "TALK" appears on the display and the display also shows the operation duration in hours, minutes and seconds.
You'll then hear a dial tone.
"HANDSET IN USE" appears on the display of the base phone and the LINE lamp on the base phone lights up.
If you hear five short error beeps and "OUT OF RANGE" appears on the display, move closer to the base phone.
- 3 Dial the phone number.
During a conversation, you can adjust the handset volume. Follow the procedure described in the following table.
- 4 When you're done talking, press **(OFF)** or place the handset on the base phone.
The display and the LINE lamp on the base phone go off.

Additional tasks

To	Do this
Adjust the handset volume	During phone conversations, press (VOL/PGM) . Each press of (VOL/PGM) switches the speaker volume by one of four levels.
Put a call on hold	Press (HOLD) . "HOLD" appears on the display. Press (HOLD) again to resume the conversation.
Switch to tone dialing temporarily	Press (*TONE) after you're connected. The line will remain in tone dialing until disconnected.

Notes

- When you increase the sound volume, in some cases the back ground noise may be increased as well. You should adjust the volume accordingly.
- If the handset beeps every second during a conversation and "OUT OF RANGE" appears on the display, move closer to the base phone; otherwise, the call will be disconnected after one minute.
- While conversing with an outside caller via the base phone, you can't make a call with the handset and "BASEPHONE IN USE" appears on the display. If you press **(TALK/ CALL WAITING/ FLASH)**, you will hear a busy tone.
- When the operation duration exceeds 9:59:59, the display counts from 0:00:00 again.

If the battery becomes weak during a call

The handset will beep every three seconds five times and  and "BATTERY LOW" appears on the display. Finish your call and charge the battery pack.

For optimum performance, charge the battery for a full 12 hours.

Note that during the first 10 - 15 minutes of charging, the phone will be inactive, i.e., unable to make or receive a call.

After this initial 10 - 15 minutes, you may be able to use the phone, but the battery duration will be very short; thus it is recommended that you fully charge the battery before the next usage.

Making calls through the speakerphone

Press **(SPEAKERPHONE)** on the base phone.
"SPEAKERPHONE" appears on the display and the display also shows the operation duration in hours, minutes and seconds.

The LINE lamp lights up.

Dial the phone number.

To adjust the speaker volume, slide the SPEAKER VOLUME control.

When you're done talking, press **(SPEAKERPHONE)** again.

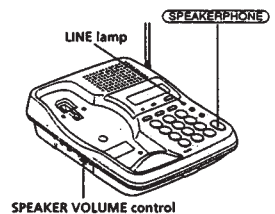
**Notes**

- While conversing with an outside caller via the handset, the display on the base phone shows "HANDSET IN USE" and you can't make a call through the speakerphone. If you press **(SPEAKERPHONE)**, you will hear a busy tone.
- When the operation duration exceeds 9:59:59, the display counts from 0:00:00 again.

continued

Making calls (continued)

To obtain the best speakerphone performance

- You may not be able to hear the other party's voice in a noisy place. Therefore, use the speakerphone in a quiet room.
- Do not bring your hand or other object too close to the microphone or you will hear a shrill noise ("feedback").
- When the speaker volume is loud, or the base phone has been placed close to a wall, you may find that the volume drops suddenly. This is due to a circuit in the telephone designed to protect against feedback. In such cases, lower the speaker volume slightly.

Redialing

- Press **(TALK/CALL WAITING/FLASH)** and wait until "TALK" appears on the display. The LINE lamp on the base phone lights up. If you're at the base phone, press **(SPEAKERPHONE)**. "SPEAKERPHONE" appears on the display and the LINE lamp lights up.
- Press **(REDIAL/PAUSE)** to redial the last number dialed.

Note
If the number exceeds 32 digits or if it is erased, five short error beeps will alert you that the number can't be redialed.

Tip
The number to be redialed is the last number dialed either on the handset or on the base phone.

To check the phone number before redialing

When not making a call with either the handset or base phone, press **(REDIAL/PAUSE)**.

The last number dialed is displayed for five seconds.

To dial the number, press **(TALK/CALL WAITING/FLASH)** while the number is displayed. If you're at the base phone, press **(SPEAKERPHONE)**.

Note
The number will not be displayed if the last number dialed exceeds 32 digits or if it is erased.

To erase the last phone number dialed

When not conversing with an outside caller with either the handset or base phone, press **(REDIAL/PAUSE)** twice within five seconds.

The number will be erased from the memory, and you'll hear a long confirmation beep.

Receiving calls

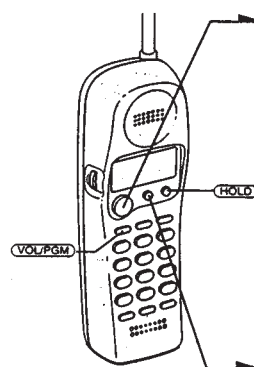

- When you hear the phone ring:
 - Press **(TALK/CALL WAITING/FLASH)**.
 - or
 - Pick up the handset from the base phone when the handset is placed on the base phone.

"TALK" appears on the display and the display also shows the operation duration in hours, minutes and seconds. "HANDSET IN USE" appears on the display of the base phone and the LINE lamp on the base phone lights up. During a conversation, you can adjust the handset volume. Follow the procedure described in the following table.
- When you're done talking, press **(OFF)** or place the handset on the base phone. The display and the LINE lamp on the base phone go off.

Additional tasks

To	Do this
Adjust the handset volume	During phone conversations, press (VOL/PGM) . Each press of (VOL/PGM) switches the speaker volume by one of four levels.
Put a call on hold	Press (HOLD) . "HOLD" appears on the display. Press (HOLD) again to resume the conversation.
Switch to another call ("call waiting" service*)	Press (TALK/CALL WAITING/FLASH) . Press (TALK/CALL WAITING/FLASH) again to return to the first caller.

* You need to subscribe to this service from your telephone company.

Note
If another call comes in by "call waiting" service while conversing with an outside caller, you will hear two short beeps.

Tip
To inform you of an incoming call, the display shows "** RINGING **" when ringing.

If you have subscribed to the Caller ID service:

- the caller's number and/or name appears on the display when you receive a call (see page 30) or when another call comes in by "call waiting" service.
- the ringer sound changes to a higher tone if the call matches the number stored on ONE-TOUCH DIAL buttons, speed dialing keys or in the Phone Directory (memory match function; see page 30).

continued

Receiving calls (continued)

To turn the ringer off

Set the RING switch on the bottom to OFF. You can save battery power.

The handset won't ring. You can still make calls, and also receive calls if another telephone connected to the same line rings to inform you on incoming calls, but you cannot receive an intercom call.

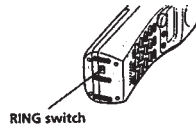

Note
You cannot receive Caller ID data when the handset is off the base phone in RING OFF mode. See page 30 for details.

Receiving calls through the speakerphone

When you hear the phone ring, press **(SPEAKERPHONE)** on the base phone. "SPEAKERPHONE" appears on the display and the display also shows the operation duration in hours, minutes and seconds.

The LINE lamp lights up.

When you're done talking, press **(SPEAKERPHONE)** again.

To obtain the best speakerphone performance, see page 14.

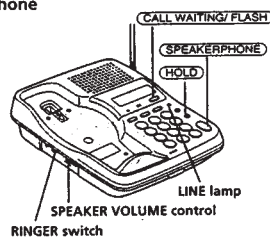

Additional tasks

To	Do this
Put a call on hold	Press (HOLD) . "HOLD" appears on the display. Press (HOLD) again to resume the conversation.
Switch to another call ("call waiting" service*)	Press (CALL WAITING/FLASH) . Press (CALL WAITING/FLASH) again to return to the first caller.
Adjust the speakerphone volume	Slide the SPEAKER VOLUME control.
Turn on/off the ringer of the base phone	Set the RINGER switch on the base phone to ON to turn the ringer on, or OFF to turn it off.

* You need to subscribe to this service from your telephone company.

Note
Even when you set the RINGER switch on the base phone to OFF, the handset will ring when the RING switch on the handset is set to ON.

Tips

- To inform you of an incoming call, the display shows "** RINGING **" and the LINE lamp lights on and off according to the ring signal even when you set the RINGER switch on the base phone to OFF.
- If there is an incoming call while on the intercom, the base phone will ring even when the RINGER switch on the base phone is set to OFF.

Telephone Features

One-touch dialing

You can dial with one touch of a key by storing a phone number on a one-touch dial button.

Storing phone numbers

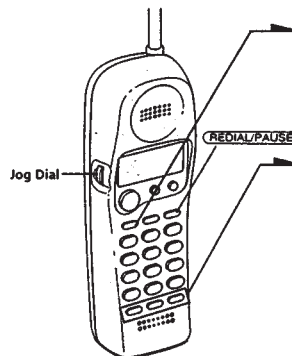

- Press **(VOL/PGM)**. **DIRECTORY AREA**
- Press one of the three ONE-TOUCH DIAL buttons (**(A)** to **(C)**). You'll hear a confirmation beep. **A= ENTER NUMBER**

If a number is stored, it appears on the display. To store a new number, turn Jog Dial to erase it.

- Enter the phone number you want to store. You can enter up to 16 digits, including a tone and a pause, each of which is counted as one digit.
- Press **(VOL/PGM)**. You'll hear a long confirmation beep, and the number is stored. The display goes off.

continued

One-touch dialing (continued)

Note

Do not allow more than 20 seconds to elapse between each step of the procedure.

Tips

- If you have entered a wrong number in step 3 and have not pressed **(VOL/PGM)** (step 4) yet, just turn Jog Dial down to erase it. Then, enter the correct number.
- You may press Jog Dial instead of **(VOL/PGM)** in step 4.

To store a number to be dialed via Private Branch Exchange (PBX)

Before entering a phone number in step 3 on page 17, do as follows:

- 1 Enter the outside line access digit (e.g., 9).
- 2 Press **(REDIAL/PAUSE)**.

To change a stored number

- 1 Press **(VOL/PGM)**.
- 2 Press one of the ONE-TOUCH DIAL buttons (**(A)** to **(C)**).
The current number appears on the display.
- 3 Turn Jog Dial down to erase the current number.
- 4 Enter a new number.
- 5 Press **(VOL/PGM)**.

Note

You can replace the stored number with a new number, but you can't just erase it.

Making calls with one-touch dialing

- 1 Press **(TALK/ CALL WAITING/ FLASH)** and wait until "TALK" appears on the display.
- 2 Press one of the ONE-TOUCH DIAL buttons (**(A)** to **(C)**).
The phone number stored on the one-touch dialing button will appear on the display and will be dialed.

To check the phone number before one-touch dialing

When not conversing with an outside caller with the handset, press one of the ONE-TOUCH DIAL buttons (**(A)** to **(C)**).

The number stored for that button appears on the display for five seconds. To dial the number, press **(TALK/ CALL WAITING/ FLASH)** while the number is displayed.

Speed dialing

You can dial with a touch of a few keys by storing a phone number on a dialing key.

Storing phone numbers

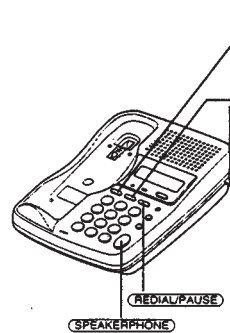

- 1 Press **(PGM)**.
"PROGRAM" appears on the display.
- 2 Press **(SPEED DIAL)**.
"ENTER 0 TO 9" appears on the display.
- 3 Press one of the dialing keys (**(0)** to **(9)**) to store a phone number on.
0= ENTER NUMBER
- 4 You'll hear a confirmation beep.
Enter the phone number you want to store.
You can enter up to 16 digits, including a tone and a pause, each of which is counted as one digit.
- 5 Press **(PGM)**.
You'll hear a long confirmation beep, and the number is stored.

Note

Do not allow more than 20 seconds to elapse between each step of the procedure.

Tips

- If you enter a wrong number in step 4, press **(PGM)**, then start from the beginning.
- Use the supplied directory to write down what you stored on the speed dialing numbers.

continued

Speed dialing (continued)

To store a number to be dialed via Private Branch Exchange (PBX)

Before entering a phone number in step 4 on page 19, do as follows:

- 1 Enter the outside line access digit (e.g., 9).
- 2 Press **(REDIAL/PAUSE)**.

To change a stored number

Store a new number, as described previously.

Making calls with speed dialing

- 1 Press **(SPEAKERPHONE)**.
- 2 Press **(SPEED DIAL)**.
- 3 Enter the desired speed dialing number (**(0)** to **(9)**).
The phone number stored as the speed dialing number will be dialed.

To check the phone number before speed dialing

When not making a call with the base phone, press **(SPEED DIAL)** and then one of the dialing keys (**(0)** to **(9)**).

The number stored on the key appears on the display for five seconds. To dial the number, press **(SPEAKERPHONE)** while the number is displayed.

Phone Directory

You can dial a number by scrolling through the Phone Directory, in which up to 50 phone numbers can be stored.

Storing phone numbers and names

Example: to store "SONY" "123-4567".

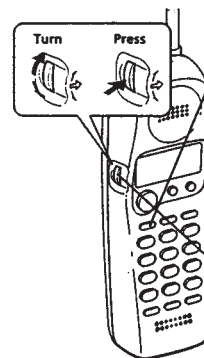

- 1 Press **(VOL/PGM)**.
(Be sure not to press **(TALK/ CALL WAITING/ FLASH)**.)
DIRECTORY (AREA)
- 2 If "DIRECTORY" is not flashing, turn Jog Dial down to make it flash.
Press Jog Dial.
"ENTER NAME" appears.
- 3 Enter the name using the dialing keys. You can enter up to 15 characters.
Press a dialing key until the desired character appears. (See the character table for details.)
Enter successive characters in the same way.

To enter two characters assigned to the same key, or to enter a "space", turn Jog Dial up to move the cursor to the right.

Example: to enter "SONY", press **(7)** four times (S), press **(6)** three times (O), turn Jog Dial up to move the cursor, press **(6)** twice (N), and press **(3)** three times (Y).

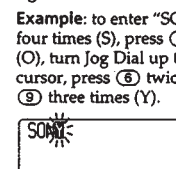

Character table

Key	Character
(1)	1
(2)	A → B → C → 2
(3)	D → E → F → 3
(4)	G → H → I → 4
(5)	J → K → L → 5
(6)	M → N → O → 6
(7)	P → Q → R → S → 7
(8)	T → U → V → 8
(9)	W → X → Y → Z → 9
(0)	0
(*)	*
(#)	#

continued

Phone Directory (continued)

4 Press **(VOL/PGM)**.
"ENTER NUMBER" appears.

5 Enter the phone number.
You can enter up to 16 digits, including a tone and a pause, each of which is counted as one digit.



6 Press **(VOL/PGM)**.
You'll hear a long confirmation beep, and the name and the number are stored. The display goes off.

Notes

- If you intend to save a 51st phone number, you will hear five short error beeps and "MEMORY FULL" will be displayed. You cannot store the phone number. To store another phone number, erase one of the stored phone numbers (see page 23).
- Do not allow more than 20 seconds to elapse between each step of the procedure.

Tips

- If you have entered a wrong name or number in step 3 or 5, turn Jog Dial down to erase it. Then enter the correct name or number.
- You may press Jog Dial instead of **(VOL/PGM)** in steps 4 and 6.
- To store a number to be dialed via PBX, follow the steps on page 18 when entering a phone number.

Changing a stored name and/or phone number

1 Display the name and phone number you want to change by doing steps 1 and 2 on page 24.

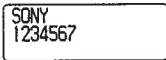

2 Press Jog Dial.

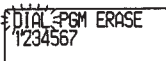

3 Turn Jog Dial up to make "PGM" flash and press Jog Dial.
The cursor flashes at the last character of the name.



4 Turn Jog Dial down to erase the characters and enter the new name.
If you want to change only the number, skip this step.

5 Press Jog dial.
The cursor flashes at the last digit of the phone number.



6 Turn Jog Dial down to erase the number and enter the new number.

If you don't want to change the number, skip this step.

7 Press Jog Dial.
You'll hear a long confirmation beep and the name and/or the number is changed.

Erasing a memory location

1 Display the name and phone number you want to erase by doing steps 1 and 2 on page 24.

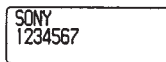

2 Press Jog Dial.

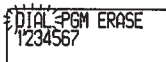

3 Turn Jog Dial up to make "ERASE" flash and press Jog Dial.



4 Turn Jog Dial up to make "YES" flash, then press Jog Dial.
You hear a long confirmation beep and the memory location is erased.

Telephone Features

continued

Phone Directory (continued)

Making calls from the Phone Directory

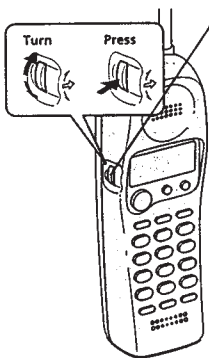

- 1** Press Jog Dial twice.
"DIRECTORY" appears on the display.
- 2** Display the name and phone number you want to call.
To search in alphabetical order: Turn Jog Dial up or down.
To search by entering the initial character: Press the dialing key of the desired character, then turn Jog Dial.

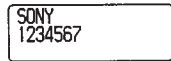

3 Press Jog Dial.

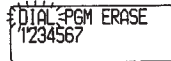

4 Press Jog Dial again.
The phone number will be dialed.

Tip
You may press **(TALK/ CALL WAITING/ FLASH)** to make a call instead of doing steps 3 and 4.

About the search order

The names appear in the following order when you turn Jog Dial up or down.

- Alphabetical order: ABC...XYZ ↔ symbols* ↔ * ↔ # ↔ 0-9
- Symbols appear only when you have stored the number having the symbol from the Caller ID list.
- Initial character: To search for "SONY" for example, press **(Z)** and then turn Jog Dial to search through the names starting with P, Q, R, S or 7.

Switching the phones during a call

You can easily switch between the handset and speakerphone on the base phone without disconnecting the call.

To switch from the base phone to the handset

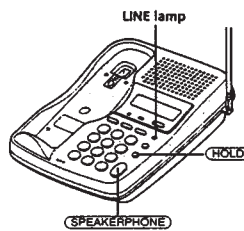

- 1** Press **(HOLD)** on the base phone.
The call is on hold and "HOLD" appears on the display and the LINE lamp on the base phone flashes.
- 2** Press **(TALK/ CALL WAITING/ FLASH)** or **(HOLD)** on the handset.
You can continue talking to the caller through the handset.

To switch from the handset to the base phone



- 1** Press **(HOLD)** on the handset.
The call is on hold and "HOLD" appears on the display and the LINE lamp on the base phone flashes.
- 2** Press **(SPEAKERPHONE)** or **(HOLD)** on the base phone.
You can continue talking to the caller through the speakerphone.

Tips

- While talking through the speakerphone on the base phone, if you pick up the handset, the call will be switched to the handset.
- When the call is put on hold on the base phone, if you pick up the handset, the call will be switched to the handset.

Telephone Features

Talking between the phones (Intercom)

You can converse using the base phone and the handset. You can start the intercom from either phone.

To talk from the handset to the base phone

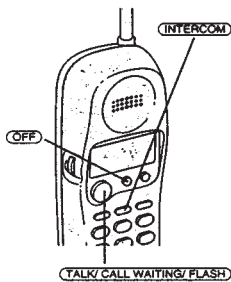

Press **(INTERCOM)**.
The base phone and handset ring and **** PAGING **** appears on the display.
When a person at the base phone presses **(SPEAKERPHONE)** or **(INTERCOM)**, you can talk with each other.
"INTERCOM" appears on the display.
When you are done talking Press **(OFF)** on the handset.
If no one answers the phone Press **(INTERCOM)** again.

To talk from the base phone to the handset

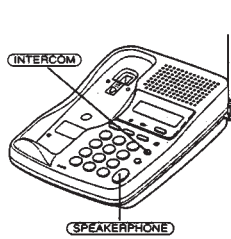

Press **(INTERCOM)**.
The base phone and handset ring and **** PAGING **** appears on the display.
When a person at the handset presses **(TALK/ CALL WAITING/ FLASH)** or **(INTERCOM)**, you can talk with each other.
"INTERCOM" appears on the display.
When you are done talking Press **(SPEAKERPHONE)** on the base phone.
If no one answers the phone Press **(INTERCOM)** again.

Notes

- You can't receive an intercom call on the handset when its RING switch is set to OFF.
- If there's an incoming call while on the intercom, only the base phone rings. To answer the call, press **(INTERCOM)** on the base phone or handset. The intercom is canceled and you can talk to the outside caller.
- While conversing with an outside caller via the base phone or handset, you cannot make an intercom call. If you press **(INTERCOM)**, you will hear a busy tone.

Tip

You can receive an intercom call on the base phone even when the RINGER switch on the base phone is set to OFF. The base phone will ring at a low level.

Voice paging

The handset user can page someone near the base phone without any operation on the base phone. Neither phones will ring.

Note that you can't page if the base phone is in use.

To page with voice

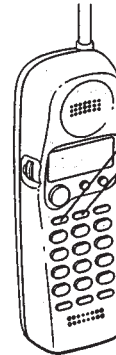

- 1 Press **(VOL/PGM)**.
- 2 Press **(INTERCOM)**.

"INTERCOM" appears on the display of both the base phone and handset, and you can begin talking.

Notes

- If there's an incoming call during voice paging, only the base phone rings. To answer the call, press **(INTERCOM)** on the base phone or handset. The paging is canceled and you can talk to the outside caller.
- While conversing with an outside caller via the base phone or handset, you cannot make an intercom call. If you press **(INTERCOM)**, you will hear a busy tone.

Transferring a call

You can transfer a call between the handset and base phone without disconnecting the call.

To transfer from the base phone to the handset



- 1 Press **(INTERCOM)** to page the handset.

The call is put on hold on the base phone and the handset rings. **** PAGING **** appears on the display of both the base phone and handset.



- 2 Press **(TALK/ CALL WAITING/ FLASH)** or **(INTERCOM)** on the handset.

"INTERCOM" appears on the display of both the handset and base phone.

You can talk between the base phone and the handset.

- 3 To talk to the caller with the handset:

- Press **(INTERCOM)** on the handset.
- or
- Press **(SPEAKERPHONE)** on the base phone.

"TALK" appears on the display of the handset.

- If no one answers the phone Press **(INTERCOM)** again.

Note

You can't receive an intercom call on the handset when its RING switch is set to OFF.

Tips

- If you have accidentally pressed **(HOLD)** in step 2, just press **(INTERCOM)** and you will get the same result as by pressing **(INTERCOM)** only.
- The LINE lamp on the base phone flashes during intercom.

To transfer from the handset to the base phone

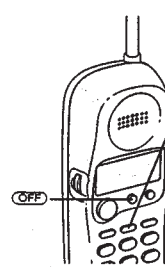

- 1 Press **(INTERCOM)** to page the base phone.

The call is put on hold on the handset and the base phone rings. **** PAGING **** appears on the display of both the handset and base phone.



- 2 Press **(SPEAKERPHONE)** or **(INTERCOM)** on the base phone.

"INTERCOM" appears on the display of both the base phone and handset.

You can talk between the handset and the base phone.

- 3 To talk to the caller with the base phone:

- Press **(INTERCOM)** on the base phone.
 - or
 - Press **(OFF)** on the handset.
- "SPEAKERPHONE"** appears on the display of the base phone.

- If no one answers the phone Press **(INTERCOM)** again.

Tip

You can receive an intercom call on the base phone even when the RINGER switch on the base phone is set to OFF. The base phone will ring at a low level.

Understanding the Caller ID service

Caller ID allows the caller's phone number to be shown on the display before the call is answered. In order to use this feature, you must first subscribe to the Caller ID service. The name of this service may vary depending on your telephone company.

To use this feature, be sure to enter your area code (see page 11).

When you receive a call

The phone number appears on the display with the date and time* as shown in the following example.

If your Caller ID service includes the caller name service, the caller's name also appears on the display (up to 15 letters).

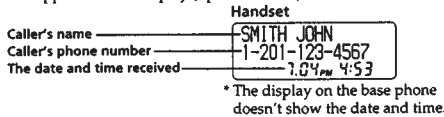

When you answer the call, the Caller ID display changes to the "TALK" or "SPEAKERPHONE" display.

Notes

- If the RING switch on the handset is set to OFF: when the handset is off the base phone, the Caller ID is not displayed, and it is not kept in the Caller ID list (see page 31). If you set it back to ON while the phone is ringing, the Caller ID appears.
- when the handset is on the base phone, the Caller ID is displayed, and it is kept in the Caller ID list.
- The caller's phone number and/or name will not appear in the following cases:
 - "OUT OF AREA": when the call is made through a telephone company which does not offer Caller ID service (including international calls).
 - "PRIVATE": when the call is "blocked." For privacy reasons, many states allow callers the option to prevent his or her telephone data from being displayed on the other party's Caller ID display.
- If the call is from an office which uses multiple lines, the displayed phone number may not match the number you use to call the extension.

About the memory match function

If you receive a call from a phone number which is stored on one of the ONE-TOUCH DIAL buttons (see page 17), speed dialing keys (see page 19) or in the Phone Directory (see page 21), the ringer sound will change to a higher tone from the second ring.

Note

The memory match function does not work with "OUT OF AREA" or "PRIVATE" calls; and it may not work with calls made from an office which uses multiple lines because the number does not always match the one you stored in this phone.

Looking at the Caller ID list

The phone stores the data of the last 20 calls received including "OUT OF AREA" and "PRIVATE" calls. It keeps track of all calls received; even if they were not answered.

However, if the RING switch on the handset is set to OFF when the handset is off the base phone, the phone can't receive the Caller ID data.

Viewing the Caller ID list

You can look through the Caller ID list to check the phone number and/or name of the calls received on the handset's display. Note that the display on the base phone shows the current caller's phone number and/or name only, and you can't view the caller ID list on the base phone.

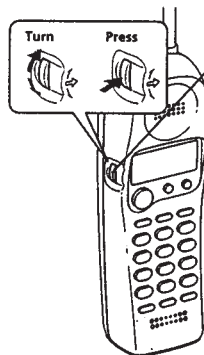

- 1 Press Jog Dial.
The display shows the number of "NEW" (calls which you have not viewed) and "OLD" (calls which you have viewed) calls.
- 2 Turn Jog Dial.
The data of the newest call appears for 20 seconds.
- 3 Turn Jog dial down to display older data or up to display newer data.

Caller ID Features

continued

Looking at the Caller ID list (continued)

Note
If a 21st call is received, the oldest data is automatically erased.

Tip
If there is a "NEW" data, the NEW CALL lamp of the base phone flashes.

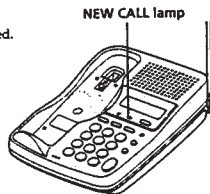

About the "*" mark

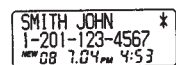

"*" appears if there are more than two calls from the same phone number. The older data will be replaced by the new data, so the calls are counted as only one call.

Erasing data from the Caller ID list

Old data will be erased automatically when a 21st call comes in, but you can also manually erase unnecessary data one by one or erase the entire list.

To erase the phone number one by one

1 Display the phone number you want to erase from the Caller ID list (see page 31).

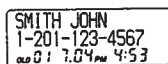

2 Press Jog Dial.

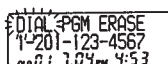

3 Turn Jog Dial up to make "ERASE" flash and press Jog Dial.

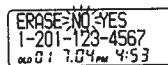

4 Turn Jog Dial up to make "YES" flash, then press Jog Dial.

You'll hear a long confirmation beep and the data is erased.

To erase the entire list at once

1 Display any Caller ID data.

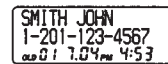

2 Press Jog Dial.

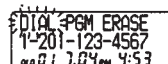

3 Turn Jog Dial up to make "ERASE" flash and press Jog Dial.

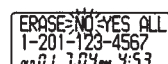

4 Turn Jog Dial up to make "ALL" flash, then press Jog Dial.

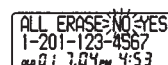

5 Turn Jog Dial up to make "YES" flash, then press Jog Dial.



You'll hear a long confirmation beep and the entire list is erased.

Note

"ALL" appears only when all the data has become "OLD" data. If there is any "NEW" data, you can't erase the entire list.

Caller ID Features

Using the Caller ID list

By using the Caller ID list, you can call back a phone number from the Caller ID list easily, or store numbers from the Caller ID list into the Phone Directory.

Calling back a number from the Caller ID list

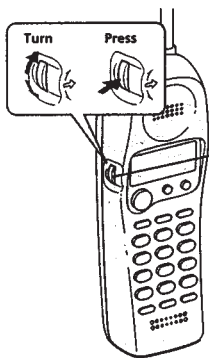

- 1 Display the phone number you want to call from the Caller ID list (see page 31).
- 2 Confirm the number and press Jog dial.
- 3 Press Jog dial again.
 The phone automatically dials the displayed number.

Notes

- If the number displayed in step 1 is not the one you should call back, you can change the number of digits of the phone number as described on page 36.
- If the phone is connected to a Private Branch Exchange (PBX), you may not be able to call back from the Caller ID list because an outside line access digit is necessary.

Tip

You may press **(TALK/ CALL WAITING/ FLASH)** to make a call instead of doing steps 2 and 3.

Storing a number of the Caller ID list into the Phone Directory

- 1 Display the name and phone number you want to store from the Caller ID list (see page 31).
- 2 Confirm the number and press Jog Dial.
- 3 Turn Jog Dial up to make "PGM" flash and press Jog Dial.
 The cursor flashes at the end of the name.
 Enter or change the name, if necessary (see page 22).
- 4 Press Jog Dial.
 The cursor flashes at the end of the phone number.
 Enter or change the phone number, if necessary (see page 22).
- 5 Press Jog Dial again.
 You'll hear a long confirmation beep and the name and number are stored.

Notes

- Do not allow more than 20 seconds to elapse between each step of the procedure.
- If the number displayed in step 1 is not the one you should call back, you can change the number of digits of the phone number as described on page 36.
- If the phone is connected to a Private Branch Exchange (PBX), you may need to add an outside line access digit.

continued

Using the Caller ID list (continued)

To change the number of digits of the phone number

If the number of digits of the phone number in the Caller ID list is different from the actual phone number, you need to adjust the number of digits of the phone number to call back or store into the Phone Directory.

- 1 While the phone number from the Caller ID list is displayed, press **(#)** repeatedly until the phone number with the correct number of digits appears on the display.
 Each time you press **(#)**, the number of digits changes as follows.

When the area code does not match

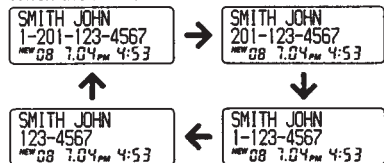

When the area code matches

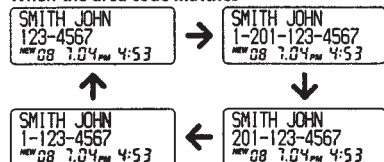

- 2 Continue the operation to call or store the phone number with the correct number of digits (pages 34 and 35).

Notes

- You need to adjust the number of digits each time you call back from the Caller ID list as the changes to the Caller ID data are not stored in memory.
- You may not be able to change the number of digits depending on the Caller ID data.

Using "Caller ID with Visual Call Waiting" service

This telephone is compatible with the "Caller ID with Visual Call Waiting" service. Make sure that your telephone company offers this service.

Like the basic Caller ID service, you need to subscribe to "Caller ID with Visual Call Waiting" in order to use this service. Even though you may have already subscribed to "Caller ID" and "call waiting" as two separate services, you need to request a subscription to "Caller ID with Visual Call Waiting" as a single service.

This is a new service that combines the two services.

Even though you now have a "Caller ID with Visual Call Waiting" compatible phone, unless you subscribe to the combined "Caller ID with Visual Call Waiting" service, you will not be able to see the name and number of the second caller.

When a new call comes in while you are talking, you hear two short beeps. The caller's name and/or phone number of the new call appears on the display for about 20 seconds.

To switch to another caller



- 1 To switch to the new caller, press **(TALK/ CALL WAITING/ FLASH)**.
- 2 To switch back to the first caller, press **(TALK/ CALL WAITING/ FLASH)** again.

SECTION 3 DISASSEMBLY

Note: Follow the disassembly procedure in the numerical order given.

• HANDSET REAR CABINET

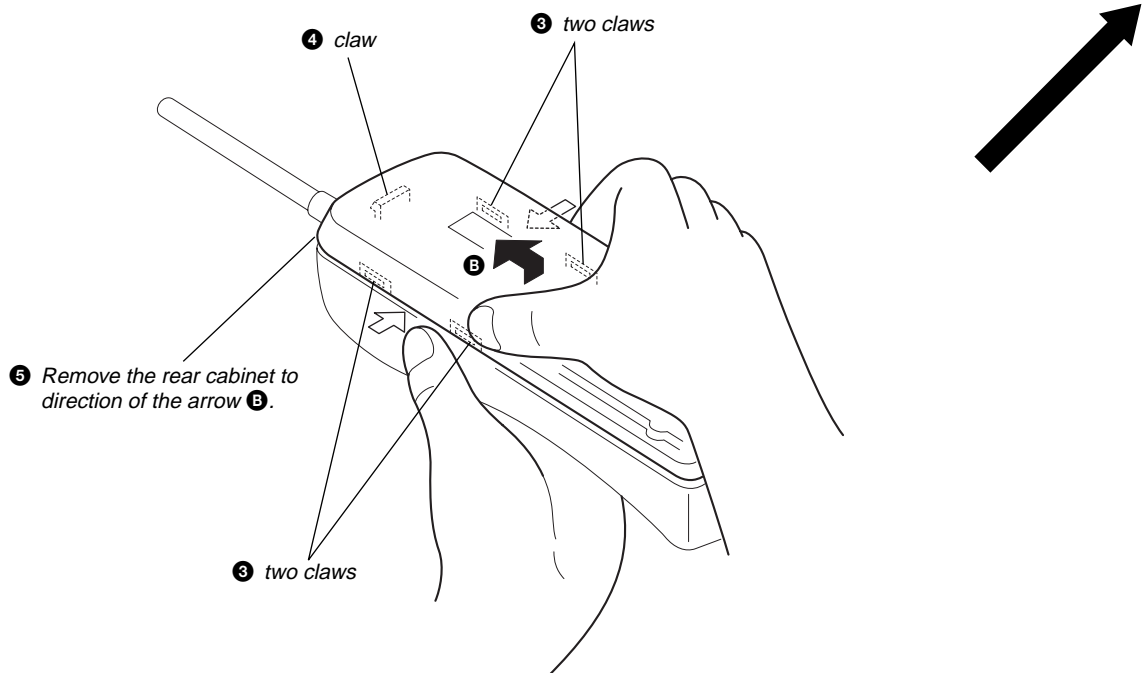
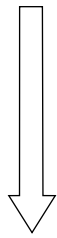
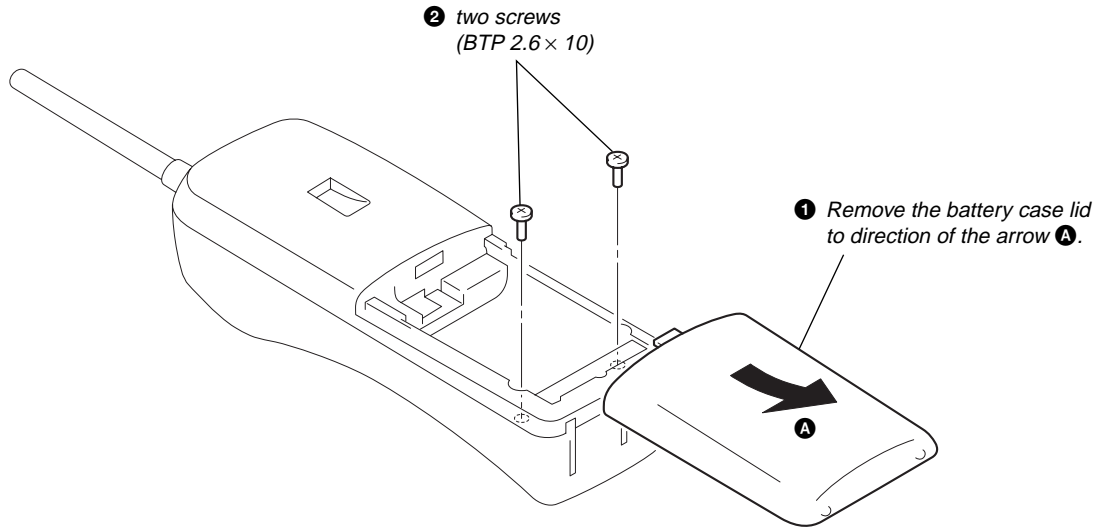

HAND MAIN BOARD

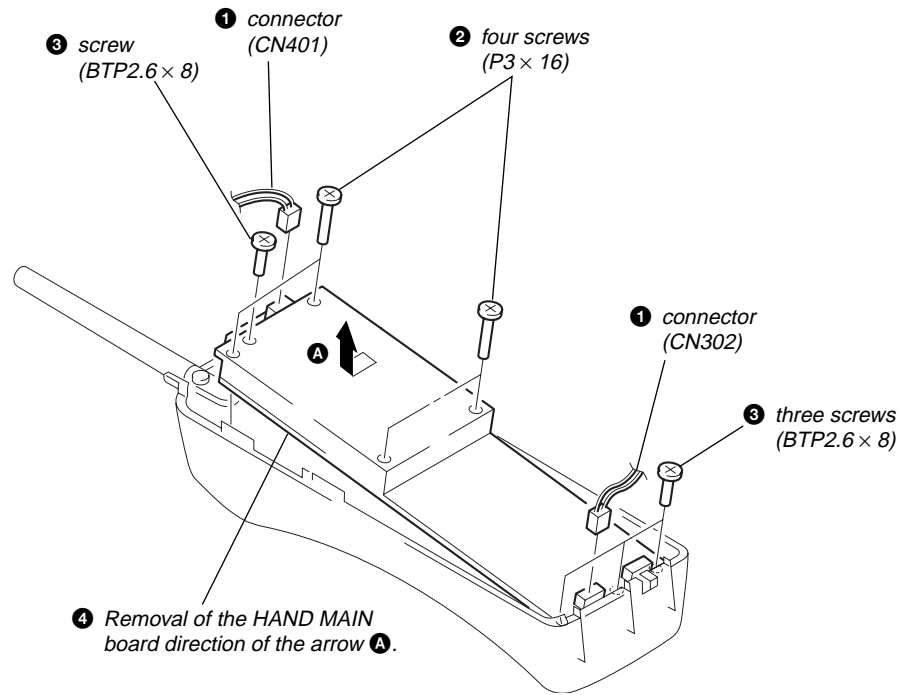

- BASESET
BASESET (UPPER) ASS'Y

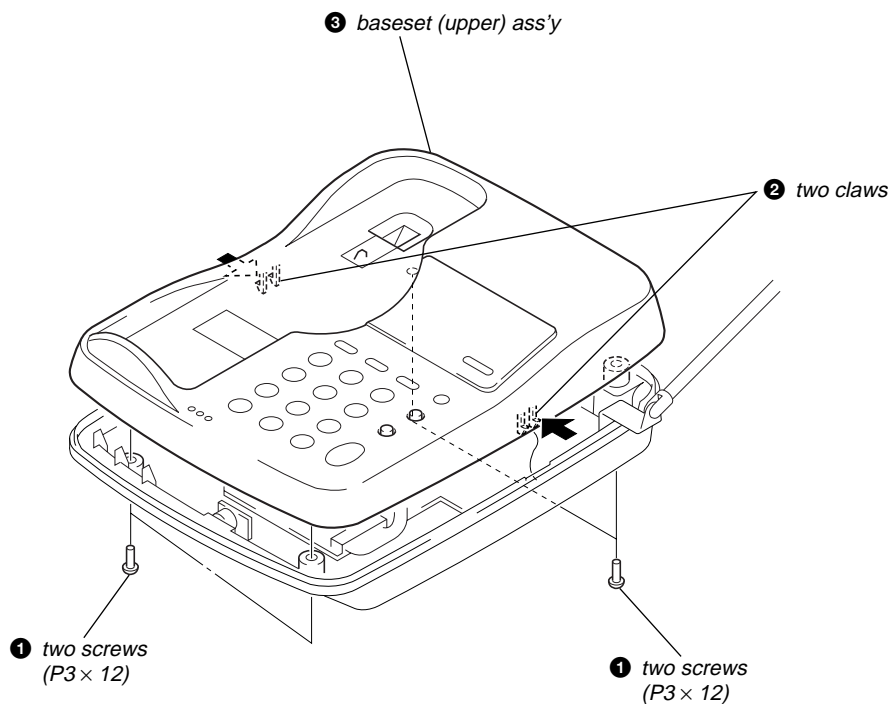

BASE MAIN BOARD

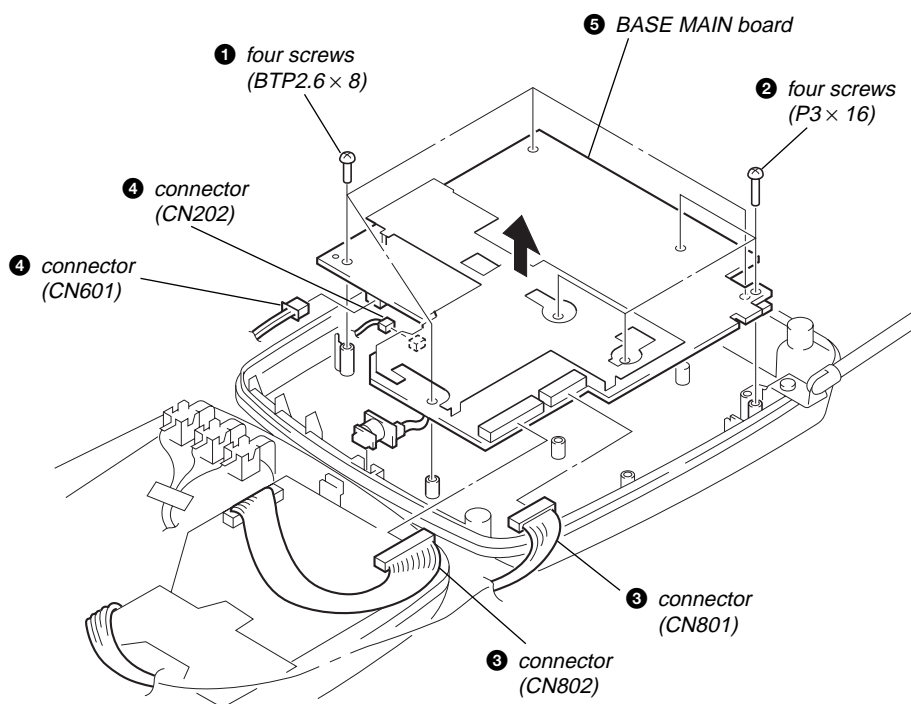

SECTION 4 900 MHz SYSTEM OPERATION

4-1. ACCESS METHOD

1. Transfer format & rate

The transfer format & rate of our system is as follows;

Table 4-1. Transfer method

Access method	FDMA-TDD
Channel number	20 channel
Channel spacing	1.2 MHz
Modulation method	DBPSK
Baseband transfer rate	960 Kbps
Spread method	Direct Sequence Spread Spectrum
Chip rate	12 chips/bit
Data transfer rate	80 Kbps

2. Channel Number & Frequencies

RF channels occupy the frequency band 902 – 928 MHz are numbered 1 to 20.

RF channel numbers & center frequencies are specified as follows.

Table 4-2. Channel number & Channel frequency

Channel Number	Channel Center Frequency (MHz)	Channel Number	Channel Center Frequency (MHz)
1	903.6	11	915.6
2	904.8	12	916.8
3	906.0	13	918.0
4	907.2	14	919.2
5	908.4	15	920.4
6	909.6	16	921.6
7	910.8	17	922.8
8	912.0	18	824.0
9	913.2	19	925.2
10	914.4	20	926.4

4-2. PROTOCOL

1. General

This system realizes the TX/RX superframe by TDD system. The relation of master/slave does not decide identification regarding the protocol between BS and HS, but the initiated side is the master and the requested side is the slave when the RF link has been established.

2. Initial acquisition

In order to establish the RF link between BS and HS, both of BS and HS need to have the same system ID. When “power” is applied to this system, the system have to do Initial Acquisition in order to have the same system ID. It is to exchange a parameter when the HS is parked on the BS, as soon as the system do System Parameters Re-initialization.

3. System parameter re-initialization

This System Parameters Re-initialization can realize that the HS is parked on the BS. So after the BS recognized to be parked the HS, the BS calculates a system parameter, and then it outputs this data from the ARTO port, and then the system establishes the RF link. In order to establish this link, the HS send the A-Frame to the BS after the HS received the system parameter, and then the BS send the A-Frame to the HS. The process of System Parameters Re-initialization is as follows.

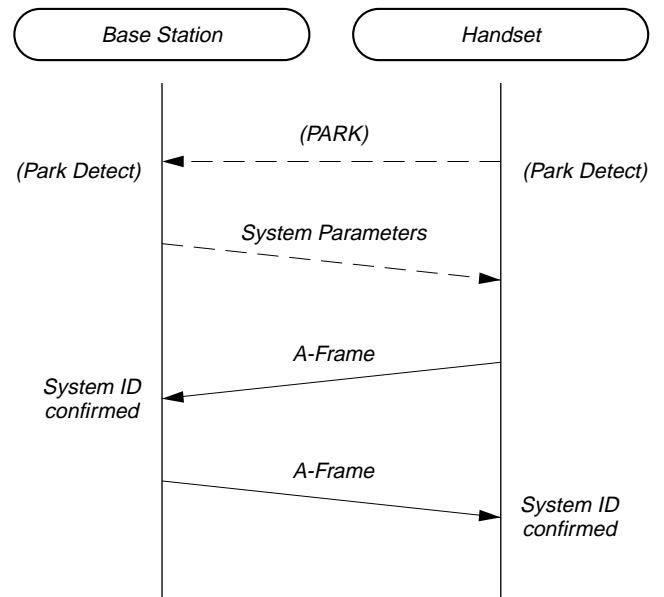

Fig. 4-1. System Parameters Re-initialization

4. Stand-by Mode Operation

(1) HS

When the HS is the stand-by mode (sleep mode), the HS do the intermittent operation for power save, because the HS is the battery operation.

This process of stand-by mode operation is as follows.

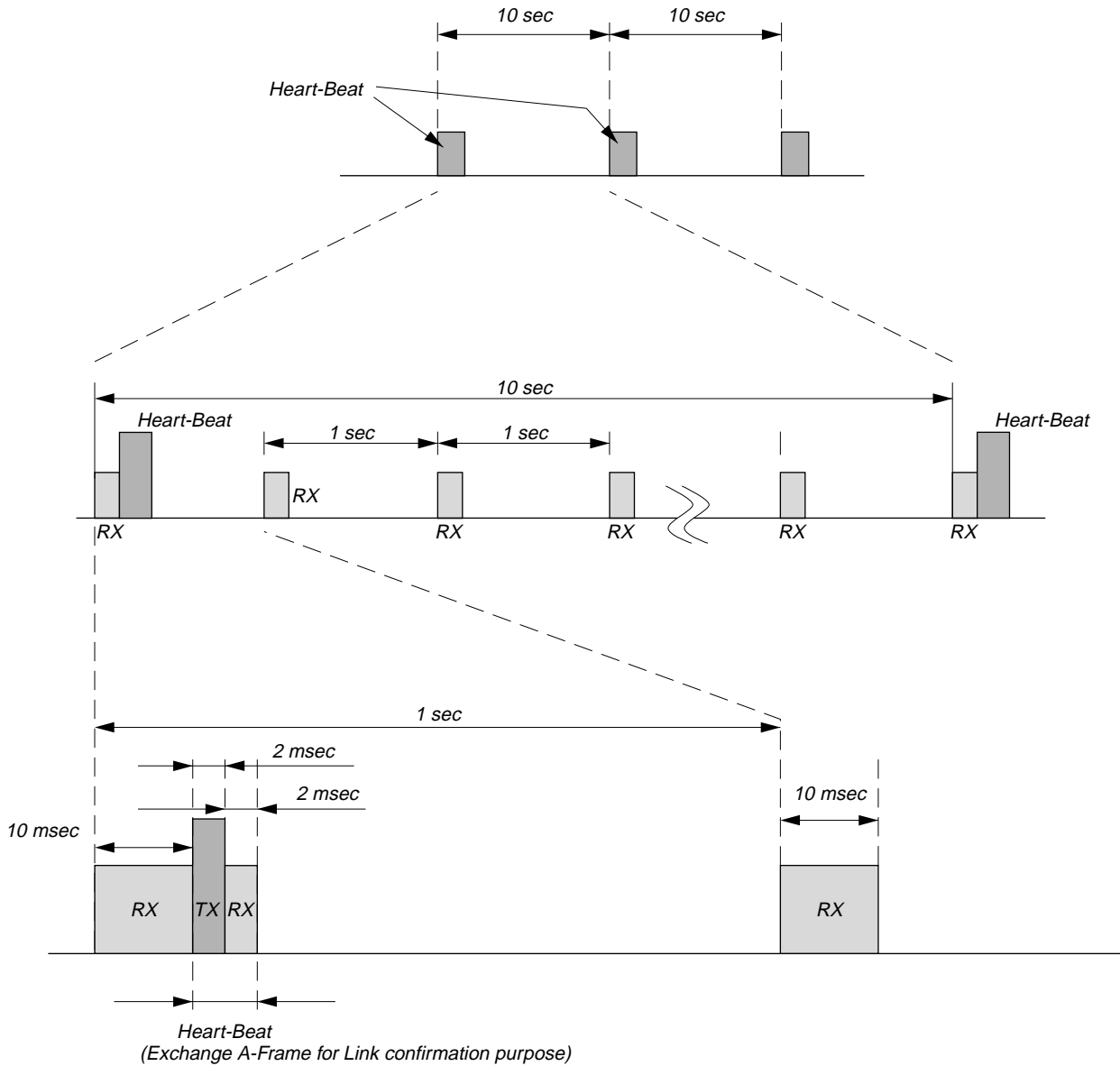

Fig. 4-2. Stand-by mode operation (HS)

(2) BS

The BS is supplied the power by AC line. While the BS is the stand-by, the BS is always a wake state. While the BS monitors the current channel, the BS monitors also the other channel at the same time

Because if the current channel can not use by some interference, the system needs the clear channel information as a part of system parameter for a channel hop.

If the BS can not receive the A-Frame of Heart-beat from the HS, it become "link error", and the system become error recovery mode.

5. Link Establishment

According to the following Fig. 4-1, the requested side for link establishment is the master.

The system have to exchange the A-Frame for link establishment, and each system ID should be the same ID, and then the system link is established.

The protocol and timing chart of link establishment are as follows.

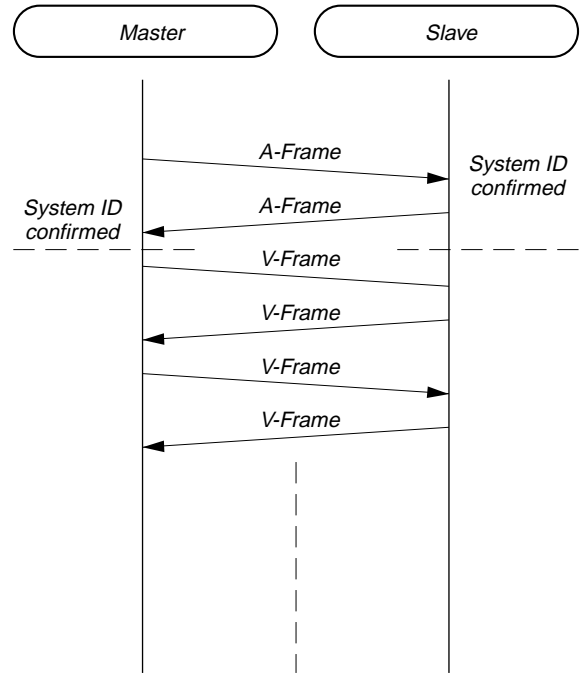

Fig. 4-3. Link Establishment protocol

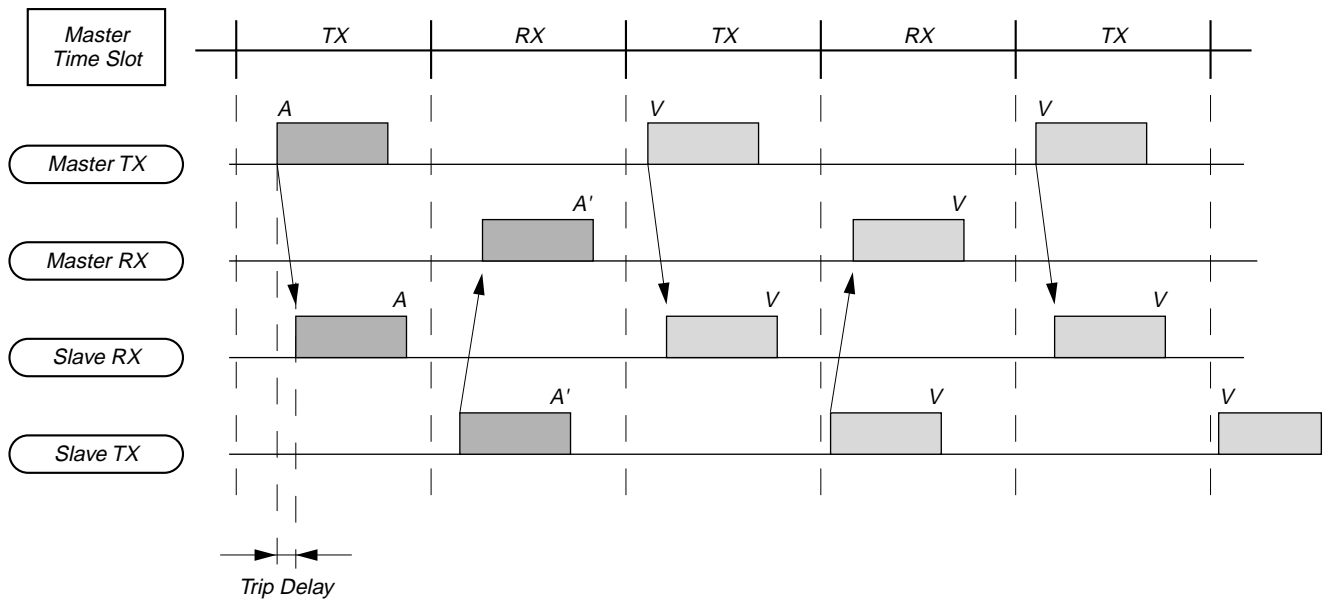

Fig. 4-4. Link Establishment Timing Chart

6. State Change/Termination

After the RF link between HS and BS was established, a movement of each state (State: ON-Hook, OFF-Hook, PAGE, InterCom, etc) is sent through supervisory bits.

7. Error Recovery

In case of the following situation, The system becomes “Error Recovery Mode”.

- (1) The system failed to move to “Heart-Beat” during “Stand-by mode, or failed “link establishment”.
- (2) The system failed to keep the link.

SECTION 5 TEST MODE

5-1. BASE UNIT

[Start-up]

1. Set the **[DIAL MODE]** switch to the P (PULSE) side.
2. Keeping the **[INTERCOM]** button pressed, turn the power on.
3. After a start-up acknowledge tone sounds, set the **[DIAL MODE]** switch from P (PULSE) to T (TONE) side, then return to the P (PULSE) side.
4. Release the **[INTERCOM]** button, and the Test Mode will start.
5. Allow for normal ringer to sound at high level for duration of 500 msec after start-up, then close the line and dial Pause → 0 (DP) → * (mode change) → 1 (tone) → 4 (tone) → 8 (tone) → # (tone).
6. After dialing, the base unit will go in Test Mode Idle status.

[Ring Detection Test]

1. The LINE LED blinks in synchronization with the RING signal and at the same time, Normal Ringer sounds, if the RING signal is detected in the Test Mode Idle status.

[Charge Detection • ARTO Output Test]

1. Square-wave signal (2.4 kHz) is output to the IC751 pin ③④ (ARTO terminal) when the CHARGE signal is detected (IC751 pin ②② (PARKP terminal) H → L) in the Test Mode Idle status.
2. At this time, the EEPROM (IC951) is reset.

[Charge Control Test]

1. IC751 pin ②⑦ (CHG-HIGH RATE terminal) outputs H → L → H once, if IC751 pin ②③ (VCHG-MON terminal) changes to H → L → H when the CHARGE signal is detected in the Test Mode Idle status.

[Test Mode by Manual Input]

- The key input in the Test Mode Idle status can change the set status to the following modes. However, the transition to another mode within respective test mode groups (A-J) is possible directly, but in case of transition to other test mode group, the set must be returned to the Test Mode Idle status once by entering the command “0-1-#”.

A) Test mode termination

Command	Mode/Operation
0-0-#	Terminate the Test mode.

B) Return test mode idle

Command	Mode/Operation
0-1-#	Return to Test Mode Idle status.

C) Continuous receiving test group (Note 1)

Command	Mode/Operation
1-1-#	CH1 continuous receiving status (LNA, AGC ON)

D) Continuous transmission test group (Note 1)

Command	Mode/Operation
2-1-#	CH1 continuous transmission status (TX Power High)
2-2-#	CH1 continuous transmission status (TX Power Mid)
2-3-#	CH1 continuous transmission status (TX Power Low)

Note 1: Each time the **[*]** key is pressed, the channels change over as follows:

CH1 → CH2 → CH3 → ... → CH20
↑

E) Loopback test group 1

Command	Mode/Operation
3-1-#	CODEC Forward Loopback (L1) (Speech path: Talk status) (LINE IN → LINE OUT: CODEC LINE IN → SPKR OUT)
3-2-#	ADPCM Forward Loopback (L2) (Speech path: Talk status) (LINE IN → CODEC → ADPCM → CODEC → LINE OUT)
3-3-#	ADPCM → RF Loopback (Speech path: Talk status) (LINE IN → CODEC → ADPCM → RF → ADPCM → CODEC → LINE OUT)

F) TDD test group 1

Command	Mode/Operation
4-1-#	CH1 TDD mode (Master timing, Power High) status
4-2-#	CH1 TDD mode (Master timing, Power Mid) status
4-3-#	CH1 TDD mode (Master timing, Power Low) status
4-4-# (Note 2)	TDD mode (Slave timing, Standby) status. Power control

Note 2: To make a speech with the handset, first operate the set in Slave mode by “4-4-#” command, and operate the counterpart in the Master mode by “6-1-#” command. However, the ID must be same. To set the same ID, perform ON-Charge in advance, or clear the EEPROM by “7-1-#” command. In this case, however, the speech path should be the intercom status.

G) MMI test group

Command	Mode/Operation
5-1-#	Key test. <ul style="list-style-type: none"> • Press the keys successively in the following order: [PGM] → [SPEED DIAL] → [REDIAL/PAUSE] → [FLASH] → [1] → [2] → [3] → [4] → [5] → [6] → [7] → [8] → [9] → [*] → [0] → [#] → [INTERCOM] → [HOLD] → [SPEAKERPHONE] • If key input sequence is correct: An acknowledge tone sounds, and the set returns to the Test Mode Idle status. • If key input sequence is wrong: An error tone sounds, and the set returns to the Test Mode Idle status.
5-3-#	LCD test. All dots on LCD lights up immediately when the LCD test mode is selected.
5-4-#	LED test. [NEW CALL] and [LINE] LEDs lights up immediately when the LED test mode is selected.

H) TDD test group 2

Command	Mode/Operation
6-1-#	TDD mode (Master timing) status. Power control. Refer to the description of “4-4-#” command.

I) Memory clear test group

Command	Mode/Operation
7-1-#	The contents of EEPROM are cleared. In case of successful clear, an acknowledge tone sounds.

J) Loopback test group 2

Command	Mode/Operation
8-1-#	ADPCM Forward Loopback (Speech path: Intercom status) (MIC IN → SPEAKER OUT: CODEC MIC IN → ADPCM → CODEC LINE OUT (Speech path: Intercom status)

5-2. HANDSET

[Start-up]

1. With the power supplied, press **[TALK]**, **[0]**, and **[1]** keys simultaneously, and the Test Mode will start.
2. Allow for normal ringer to sound at high level for duration of 500 msec after start-up, then the handset will go in Test Mode Idle status.
3. The RF in Talk/Intercom status is as follows.
TALK LED lights up.

[Test Mode by Manual Input]

- The key input in the Test Mode Idle status can change the set status to the following modes. However, the transition to another mode within respective test mode groups (A-J) is possible directly, but in case of transition to other test mode group, the set must be returned to the Test Mode Idle status once by entering the command “0-1-#”.

A) Test mode termination

Command	Mode/Operation
0-0-#	The Test mode terminates. The contents of EEPROM are cleared. In case of successful clear, an acknowledge tone sounds.

B) Return test mode idle

Command	Mode/Operation
0-1-#	Return to Test Mode Idle status.

C) Continuous receiving test group (Note 1)

Command	Mode/Operation
1-1-#	CH1 continuous receiving status (LNA, AGC ON)

D) Continuous transmission test group (Note 1)

Command	Description
2-1-#	CH1 continuous transmission status (TX Power High)
2-2-#	CH1 continuous transmission status (TX Power Mid)
2-3-#	CH1 continuous transmission status (TX Power Low)

Note 1: Each time the **[*]** key is pressed, the channels change over as follows:

CH1 → CH2 → CH3 → ... → CH20

E) Loopback test group 1

Command	Mode/Operation
3-1-#	CODEC Forward Loopback (L1) (MIC → SP) (within CODEC)
3-2-#	ADPCM Forward Loopback (L2) (MIC → CODEC → ADPCM → CODEC → SP)
3-3-#	ADPCM → RF Loopback (MIC → CODEC → ADPCM → RF → ADPCM → CODEC → SP)

F) TDD test group 1

Command	Mode/Operation
4-1-#	CH1 TDD mode (Master timing, Power High) status
4-2-#	CH1 TDD mode (Master timing, Power Mid) status
4-3-#	CH1 TDD mode (Master timing, Power Low) status
4-4-#	TDD mode (Slave timing, Standby) status. Power control

G) MMI test group

Command	Mode/Operation
5-1-#	Key test. • Press the keys successively in the following order: [TALK/FLASH] → [OFF] → [HOLD] → [PGM] → [INTERCOM] → [REDIAL/PAUSE] → [1] → [2] → [3] → [4] → [5] → [6] → [7] → [8] → [9] → [*] → [0] → [#] → [SPEED DIAL]
	• If key input sequence is correct: An acknowledge tone sounds, and the set returns to the Test Mode Idle status. • If key input sequence is wrong: An error tone sounds, and the set returns to the Test Mode Idle status.
5-2-#	JOG shuttle test. (Note 2)
5-3-#	LCD test. All dots on LCD lights up immediately when the LCD test mode is selected.

Note 2: JOG shuttle test

The JOG shuttle test mode makes a check with the LCD display when JOG shuttle is rotated clockwise or counterclockwise, or the button is pressed.

JOG shuttle	LCD display
Rotate clockwise	“R” is displayed at 1st digit on 1st line
Rotate counterclockwise	“L” is displayed at 1st digit on 1st line
Press button	“P” is displayed at 1st digit on 1st line

H) TDD test group 2

Command	Mode/Operation
6-1-#	TDD mode (Master timing) status.

I) Memory clear test group

Command	Mode/Operation
7-1-#	The contents of EEPROM are cleared. In case of successful clear, an acknowledge tone sounds.

J) Battery save mode

Command	Mode/Operation
9-0-#	Battery Save mode.

5-3. RF TESTING

This test is for checking the RF system without disassembling the set in servicing. Perform measurement using the spectrum analyzer and jig antenna.

5-3-1. RF Testing method

Please follow the below instruction to perform RF test.

[Setting Condition]

Connect a receiving antenna to RF INPUT of Spectrum analyzer and set the unit 10 cm (4 inches) away from the receiving antenna.

Measuring tool: Spectrum analyzer (equivalent to HP8595E)

Jig: Receiving antenna (for Spectrum analyzer)

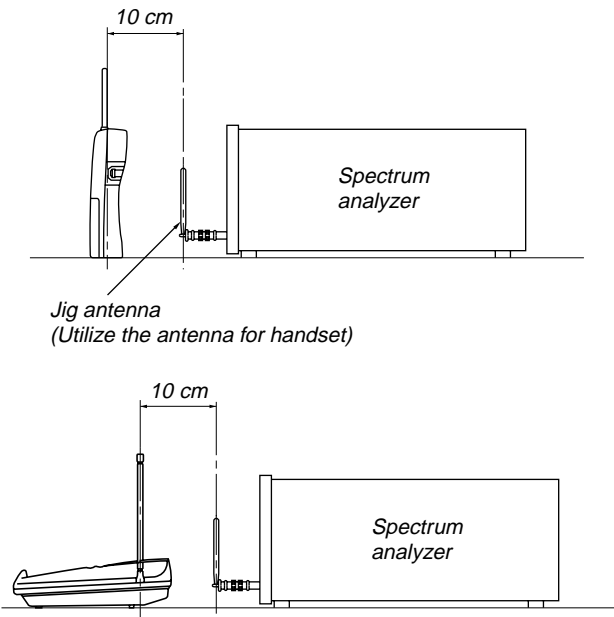

• Transmission Wave:

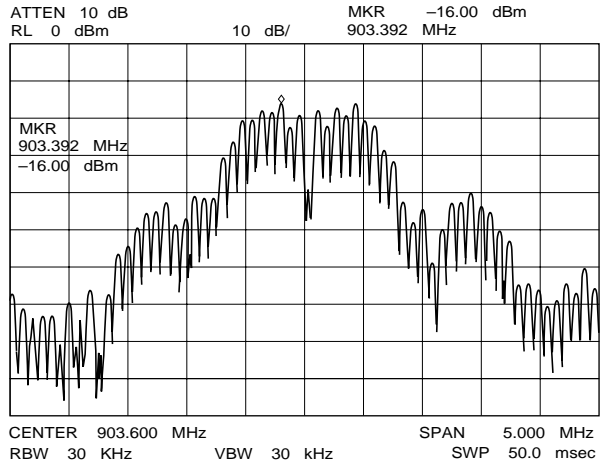

Fig. 1

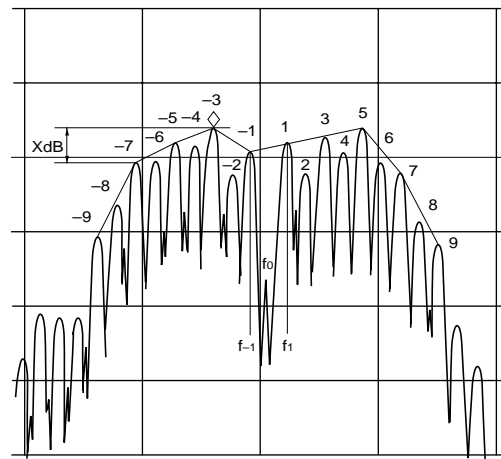

Fig. 2

[Check the Transmission Wave]

Purpose

It is necessary to check spectrum wave of transmission wave which is an important factor in order to confirm operational performance of Spread Spectrum models. If this wave deviates from correct wave form, normal data transmission cannot be made and, as a result of that, possibility that occurrence of mute increases and communication distance becomes shorter will increase.

Measuring process

- Setting Spectrum analyzer:
Center frequency : 903.6 MHz (CH1)
RBW : 30 kHz
VBW : 30 kHz
Span : 3 MHz (or 5MHz)
- Setting Test mode:
Continuous Transmit mode (CH1 High Power)
(Refer to "Test Mode" on page 18)
- Measurement:
Measure transmitting wave.
- Specifications:
Acceptable level [XdB] difference between the highest peak and the lowest peak of odd side band (the first to seventh side band from Center Frequency ; Transmission Frequency f_0 : CH1) is under 10 dB. (Refer Fig. 1 and Fig. 2)
If output wave form deteriorates, side band appears like Fig. 3 and Fig. 4.

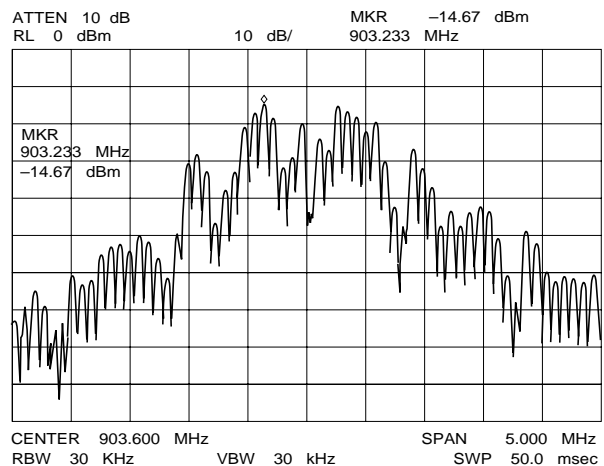

Fig. 3

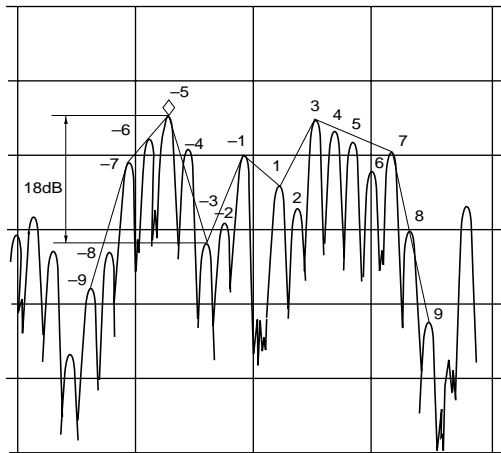
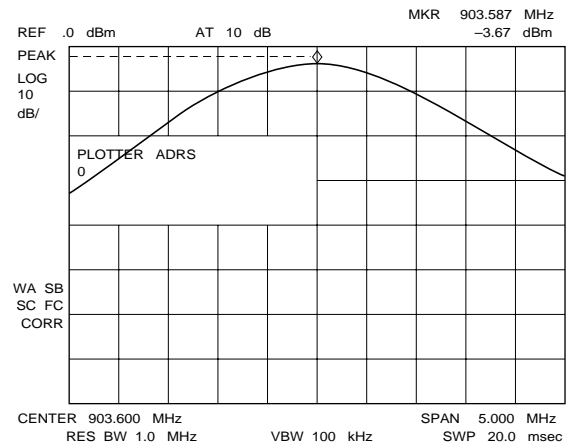

Fig. 4

- Measurement:
Measure peak level by Spectrum analyzer.



[Check Center Frequency]

Measuring process

- Setting Spectrum analyzer:
Center frequency : 903.6 MHz (CH1)
RBW : 10 kHz
VBW : 10 kHz
Span : 1 MHz
- Setting Test mode:
Continuous Transmit mode (CH1 High Power)
(Refer to “Test Mode” on page 18)
- Measurement:
Measure transmitting wave f_0 (Formula of center frequency)
(Refer Fig.5)
- Specification:
903.6 MHz \pm 27 kHz

Center Frequency:

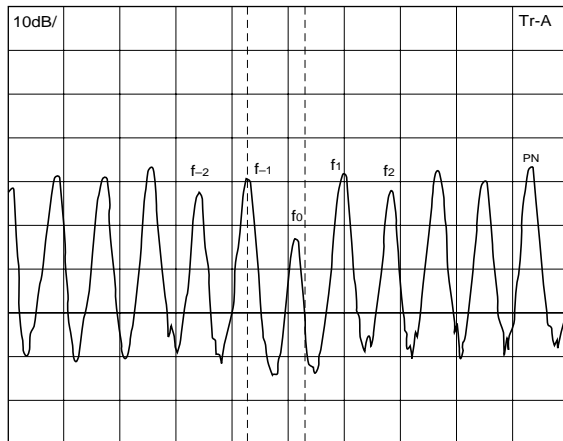

Fig. 5

DATA

(UNIT; dbm)

NO	HANDSET			BASESET		
	HIGH	MID	LOW	HIGH	MID	LOW
1	-3.93	-20.95	-34.53	-2.36	-19.17	-32.81
2	-3.70	-20.36	-33.75	-1.52	-18.33	-30.79
3	-4.47	-21.48	-34.78	-4.36	-18.65	-33.3
4	-4.64	-21.85	-35.12	-4.25	-19.37	-33.05
5	-4.52	-21.18	-35.54	-2.35	-19.05	-32.95
6	-4.02	-21.57	-35.12	-2.96	-19.14	-33.45
7	-5.03	-22.14	-35.45	-4.12	-19.12	-33.01
8	-5.58	-22.35	-35.61	-2.89	-18.56	-32.12
9	-4.03	-21.32	-35.82	-5.01	-18.33	-32.41
10	-4.43	-19.69	-33.92	-2.74	-17.28	-31.33
×	-4.435	-21.29	-34.96	-3.256	-18.7	-32.52
σ	0.5336	0.7634	0.6747	1.0562	0.5895	0.8273
$\times + 4\sigma$	-2.301	-18.24	-32.27	0.9687	-16.34	-29.21
$\times - 4\sigma$	-6.569	-24.34	-37.66	-7.481	-21.06	-35.83

- Specification:
HANDSET MIN -17 dBm
(at High power: Include location loss)
BASE SET MIN -18 dBm
(at High power: Include location loss)

[Confirm Transmitting output]

Measuring process

- Setting Spectrum analyzer:
Center frequency : 903.6 MHz (CH1)
RBW : 1 MHz
VBW : 100 kHz
Span : 5 MHz
- Setting Test mode:
Continuous Transmit mode (CH1 High Power)
(Refer to “Test Mode” on page 18)

SECTION 6 ELECTRICAL ADJUSTMENTS

6-1. BASE UNIT SECTION

- Make the set in Test mode (see page 18)

1. Checking RX I&Q Output Level

Setting:

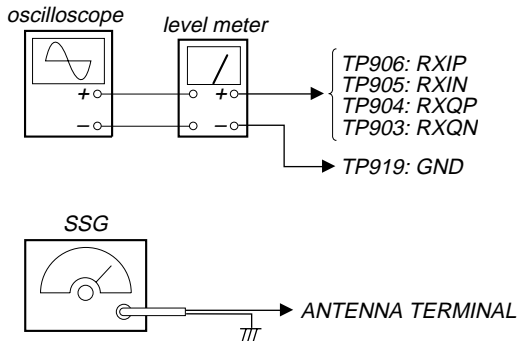

Procedure:

1. Place the base unit in the Continuous Receive mode (CH1, LNA ON, AGC ON).
2. Set the SSG frequency to the frequency on CH1 + 300 kHz, and the RF output level to -95 dBm.
3. Measure the output level of RXIN, RXIP, RXQN and RXQP with a level meter. At this time, confirm with an oscilloscope that a sine wave of 300 kHz is output.
4. Confirm that the measured output level is -31.0 to -24.0 (TYPICAL -27.0) dBV. If IC951 was replaced (there is no ID data), the output level is -31.0 to -24.0 dBV.
5. Also, execute steps 1 through 4 for the channels 10 and 20.

* For the frequency on each channel, see page 15.

2. Checking TX Center Frequency

Setting :

- short: TP918 ↔ TP919

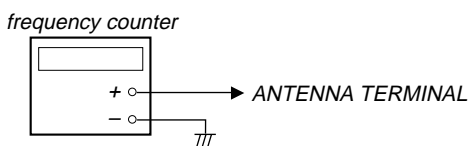

Procedure:

1. Short TP918 and TP919 (GND) on the BASE MAIN board in the base unit.
2. Place the base unit in the Continuous Transmit mode (CH1, High power).
3. Measure the ANT OUT frequency of the RF module in the base unit using a frequency counter.
4. Confirm that the measured frequency is 903.600 MHz ± 27 kHz.

3. Checking TX Output

Setting:

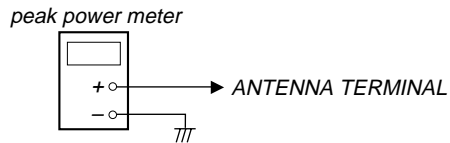

Procedure:

1. Place the base unit in the Continuous Transmit mode (CH1, High power).
2. Measure the ANT OUT output of the RF module in the base unit using a peak power meter.
3. Confirm that the measured output is 80 mW (MIN 30 mW).
4. Also, execute steps 1 through 4 for the channels 10 and 20.
CH10: 80 mW (MIN 30 mW)
CH20: 75 mW (MIN 25 mW)

6-2. HANDSET SECTION

- Make the set in Test mode (see page 19)

1. Checking RX I&Q Output Level

Setting:

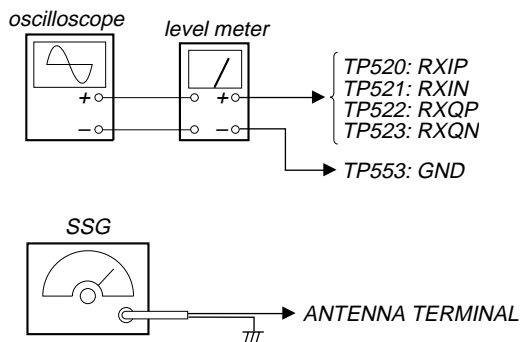

Procedure:

1. Place the handset in the Continuous Receive mode (CH1, LNA, AGC ON).
2. Set the SSG frequency to the frequency on CH1 + 300 kHz, and the RF output level to -95 dBm.
3. Measure the output level of RXIN, RXIP, RXQN, and RXQP with a level meter. At this time, confirm with an oscilloscope that a sine wave of 300 kHz is output.
4. Confirm that the measured output level is -31.0 to -24.0 (TYPICAL -27.0) dBV. If IC502 was replaced (there is no ID data), the output level is -31.0 to -24.0 dBV.
5. Also, execute steps 1 through 4 for the channels 10 and 20.

* For the frequency on each channel, see page 15.

2. Checking TX Center Frequency

Setting:

- short: TP555 ↔ TP553

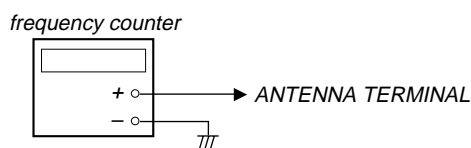

Procedure:

1. Short TP555 and TP553 (GND) on the HAND MAIN board in the handset.
2. Place the handset in the Continuous Transmit mode (CH1, High power).
3. Measure the ANT OUT frequency of the RF module in the handset using a frequency counter.
4. Confirm that the measured frequency is 903.600 MHz ± 27 kHz.
5. Also, execute steps 1 through 4 for the channels 10 and 20.

3. Checking TX output

Setting:

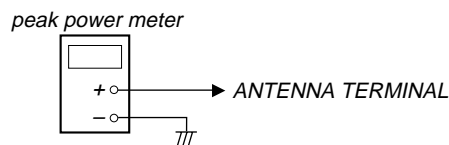

Procedure:

1. Place the handset in the Continuous Transmit mode (CH1, High power).
2. Measure the ANT OUT output of the RF module in the handset using a peak power meter.
3. Confirm that the measured output is 80 mW (MIN 20 mW).
4. Also, execute steps 1 through 3 for the channels 10 and 20.
CH10: 80 mW (MIN 20 mW)
CH20: 50 mW (MIN 10 mW)

Adjustment Location:

[BASE MAIN board]
(Side B)

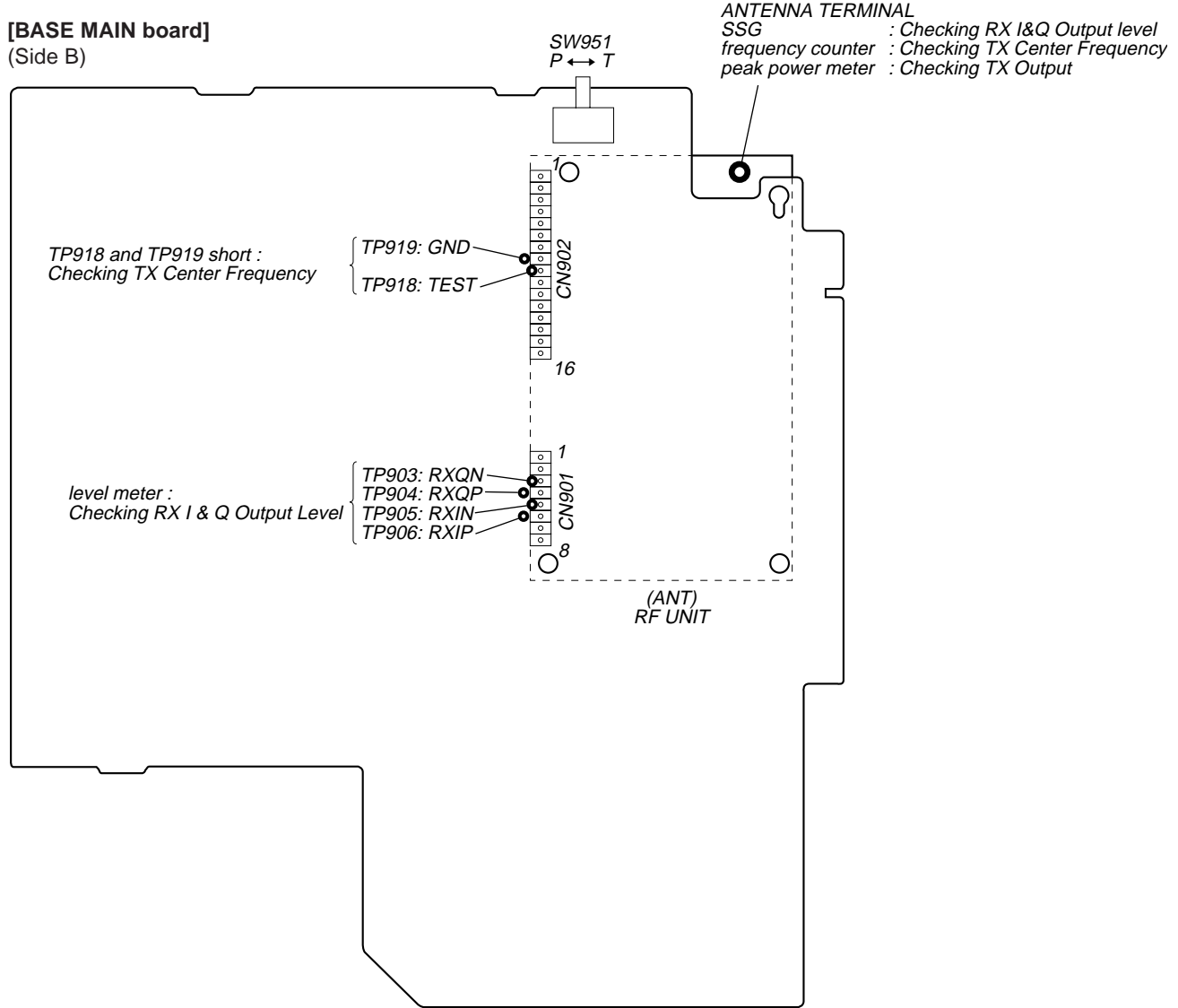

[HAND MAIN board]
(Side A)

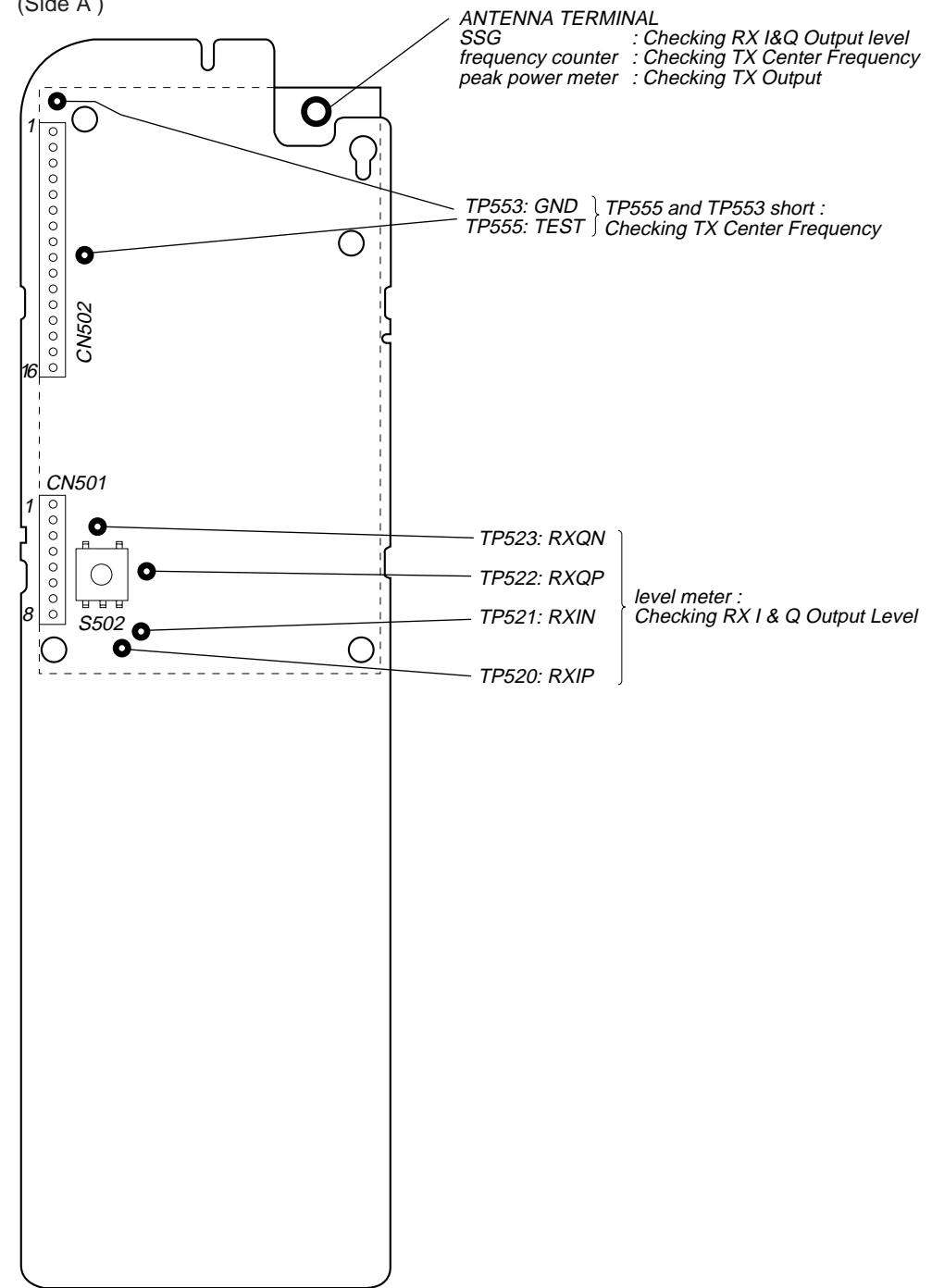

SECTION 7
DIAGRAMS

7-1. BLOCK DIAGRAM - BASE UNIT Section (1/2) -

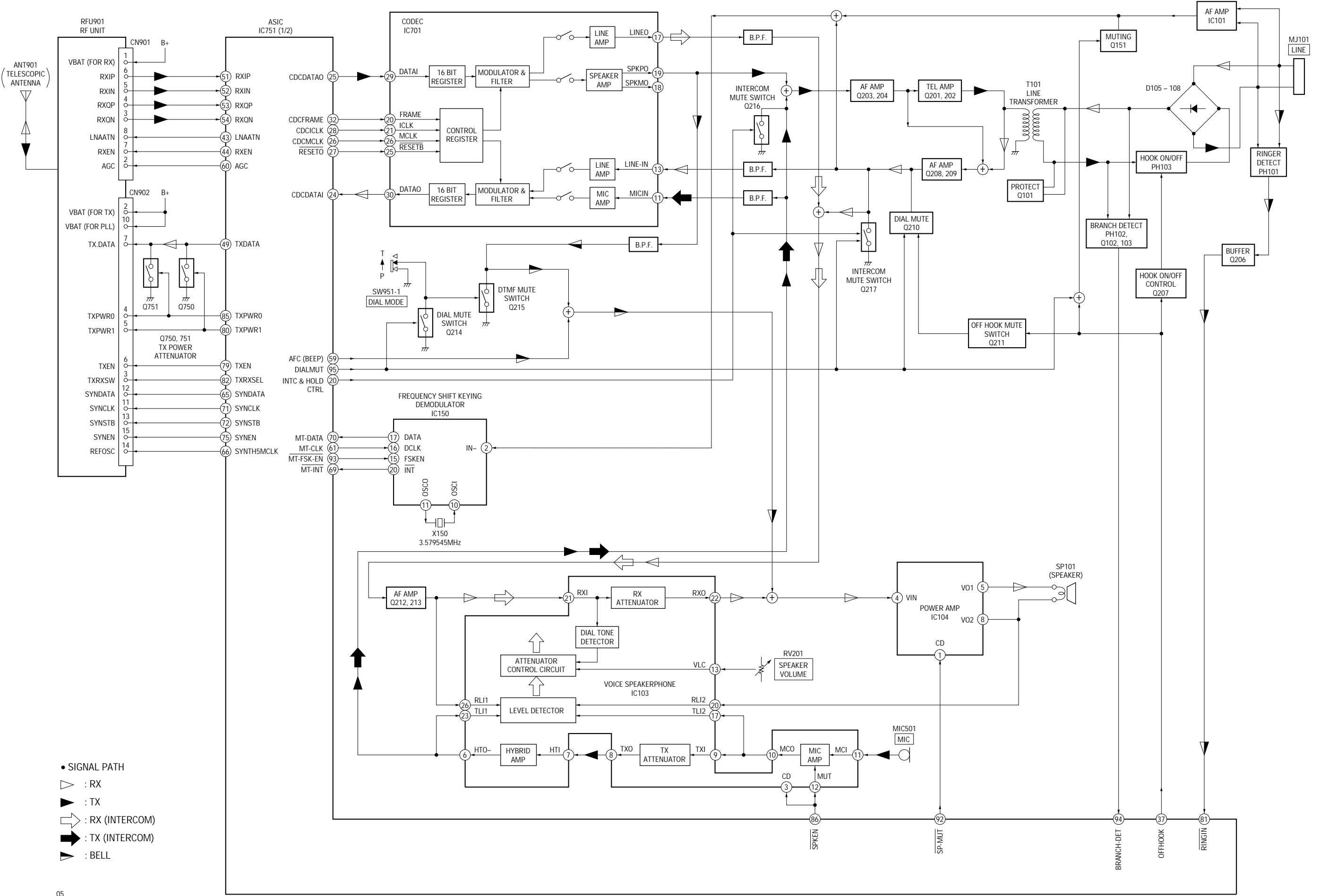

- SIGNAL PATH
- ▷ : RX
- ◀ : TX
- ⇄ : RX (INTERCOM)
- ⇄ : TX (INTERCOM)
- ▽ : BELL

7-2. BLOCK DIAGRAM – BASE UNIT Section (2/2) –

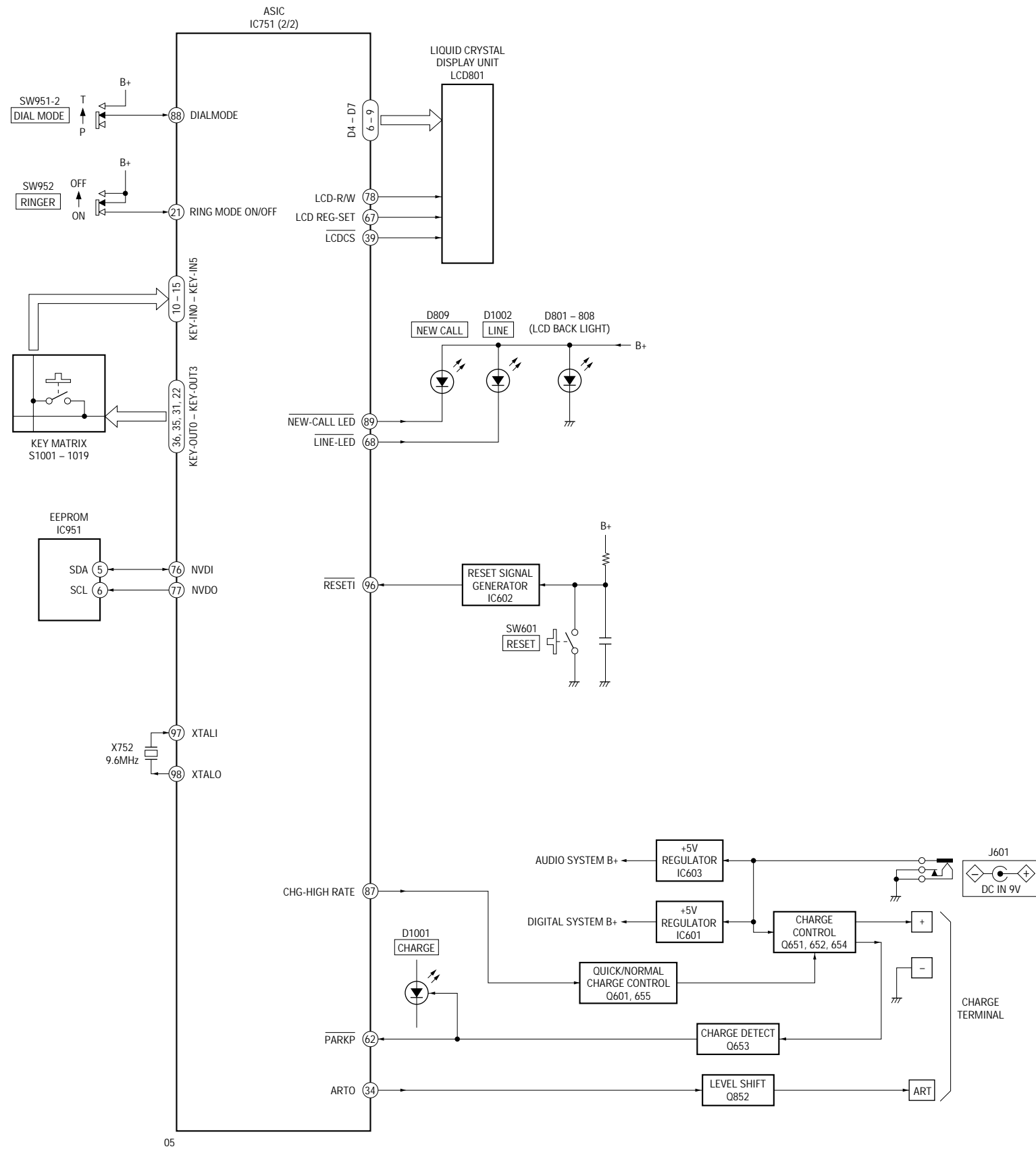



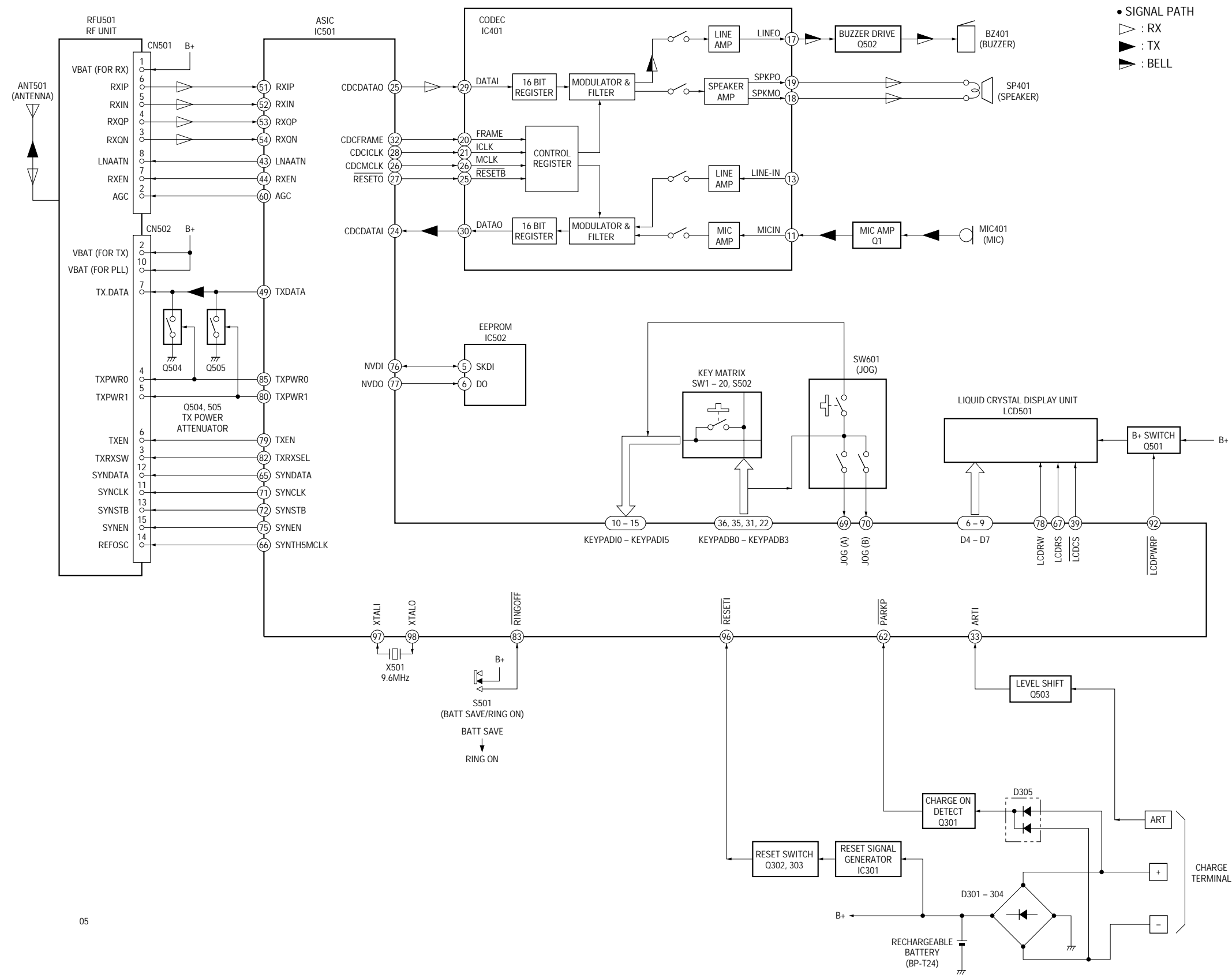

7-3. BLOCK DIAGRAM – HANDSET Section –



05

7-4. NOTES FOR PRINTED WIRING BOARDS AND SCHEMATIC DIAGRAMS

Note on Printed Wiring Board:

-  : parts extracted from the component side.
-  : parts extracted from the conductor side.
-  : parts mounted on the conductor side.
-  : Pattern from the side which enables seeing.

Caution:

Pattern face side: Parts on the pattern face side seen from the pattern face are indicated.
 (Side B)
 Parts face side: Parts on the parts face side seen from the parts face are indicated.
 (Side A)

- Indication of transistor.

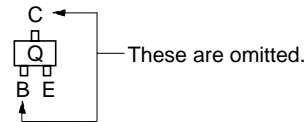

Note on Schematic Diagram:







- All capacitors are in μF unless otherwise noted. pF: μpF 50 WV or less are not indicated except for electrolytics and tantalums.
- All resistors are in Ω and $1/4\text{ W}$ or less unless otherwise specified.
-  : panel designation.

Note:

The components identified by mark \triangle or dotted line with mark \triangle are critical for safety. Replace only with part number specified.

Note:

Les composants identifiés par une marque \triangle sont critiques pour la sécurité. Ne les remplacer que par une pièce portant le numéro spécifié.

-  : B+ Line.
- Power voltage is dc 9 V and fed with regulated dc power supply from external power voltage jack (J601 on the BASE MAIN board).
- Power voltage is dc 12 V and fed with regulated dc power supply from modular jack (MJ101 on the BASE MAIN board) with $100\ \Omega$ in series.
- Power voltage is dc 3.6 V and fed with regulated dc power supply from battery terminal (CN301 on the HAND MAIN board).
- Voltages and waveforms are dc with respect to ground in test mode.
- Voltages are taken with a VOM (Input impedance $10\ \text{M}\Omega$). Voltage variations may be noted due to normal production tolerances.
- Waveforms are taken with a oscilloscope. Voltage variations may be noted due to normal production tolerances.
- Circled numbers refer to waveforms.
- Signal path.
 -  : RX
 -  : RX(INTERCOM)
 -  : TX
 -  : TX(INTERCOM)
 -  : bell

• Waveforms – BASE MAIN Board –

① IC751 ⑨ (XTALI)

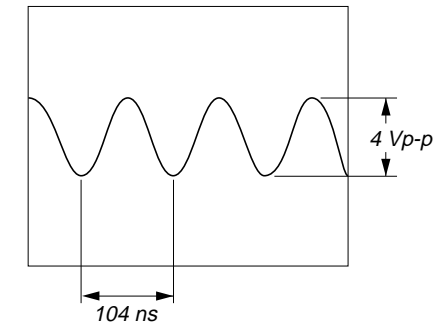

② IC150 ⑩ (OSCI)

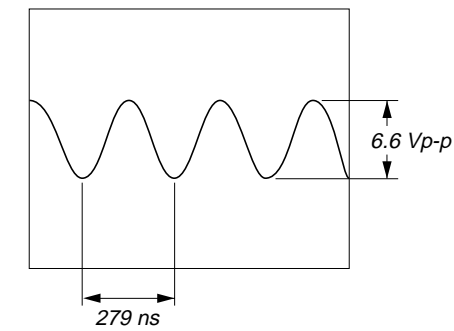

– HAND MAIN Board –

① IC751 ⑨ (XTALI)

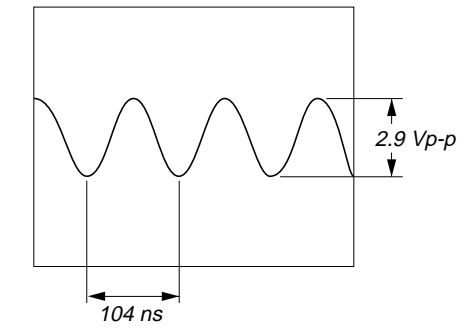

7-5. PRINTED WIRING BOARDS – BASE MAIN Board (Side A)/BASE MICROPHONE Board –

• Semiconductor Location (SIDE A)

Ref. No.	Location
IC101	G-6
IC150	E-6
IC602	G-4
IC701	F-2
IC751	D-3
IC951	B-4
Q208	E-9
Q209	F-10
Q210	F-11
Q211	F-11

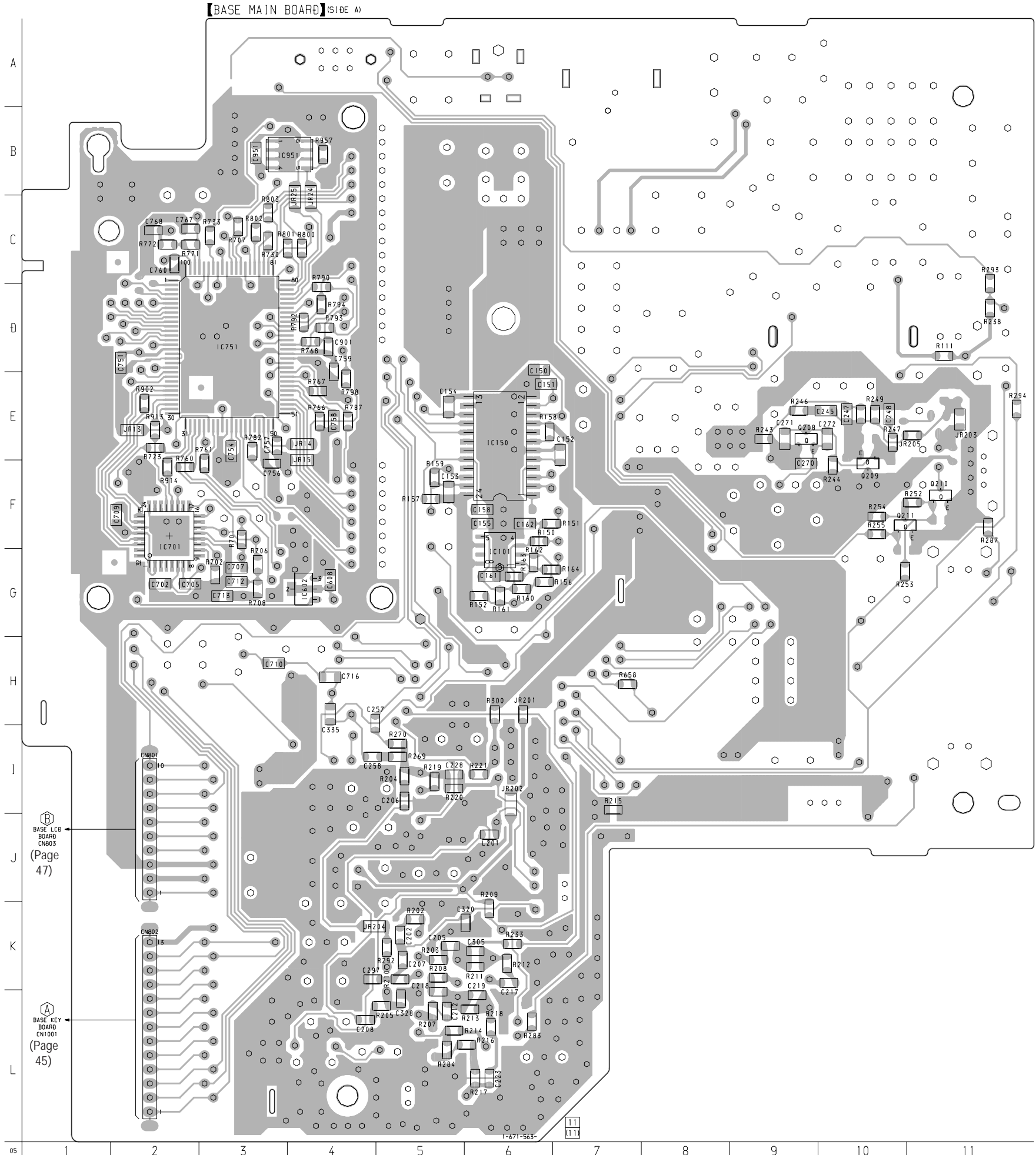

【BASE MICROPHONE BOARD】 (SIDE A)

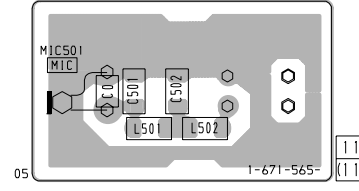

【BASE MICROPHONE BOARD】 (SIDE B)

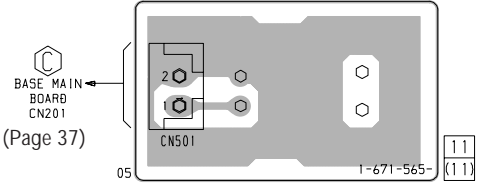

7-6. PRINTED WIRING BOARD – BASE MAIN Board (Side B) –

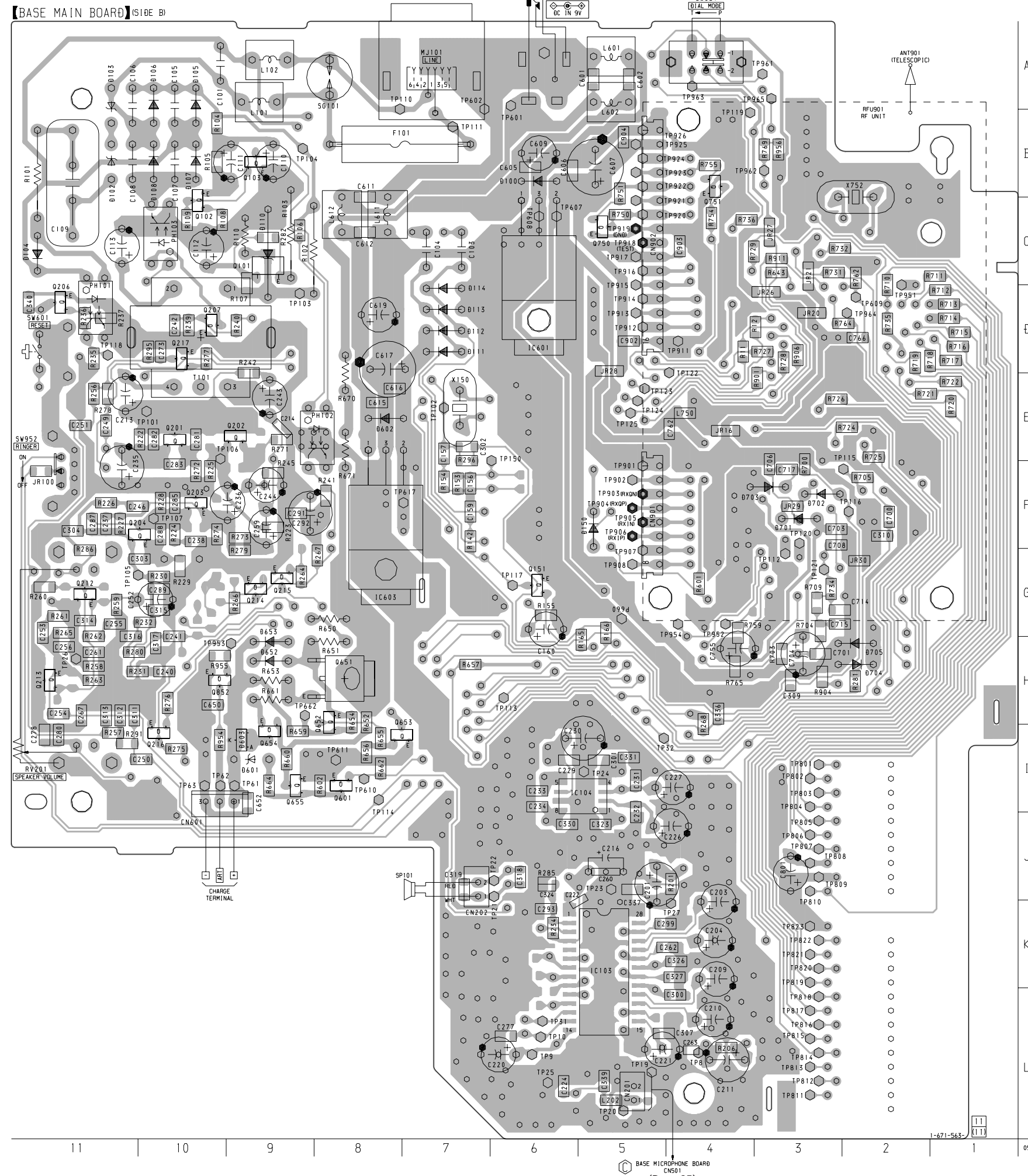

• Semiconductor Location (SIDE B)

Ref. No.	Location
D100	B-6
D102	B-11
D103	A-11
D104	C-11
D105	A-10
D106	A-10
D107	B-10
D108	B-10
D110	C-9
D111	D-7
D112	D-7
D113	D-7
D114	D-7
D150	F-5
D601	I-9
D602	E-8
D603	I-9
D652	H-9
D653	H-9
D701	F-3
D702	F-3
D703	F-3
D704	H-2
D705	H-2
IC103	K-5
IC104	I-5
IC601	D-6
IC603	F-8
PH101	D-11
PH102	E-8
PH103	C-10
Q101	C-9
Q102	C-10
Q103	B-9
Q151	G-6
Q201	E-10
Q202	E-9
Q203	F-10
Q204	F-10
Q206	D-11
Q207	D-10
Q212	G-11
Q213	H-11
Q214	G-9
Q215	G-9
Q216	I-10
Q217	D-10
Q601	I-8
Q651	H-8
Q652	I-8
Q653	I-7
Q654	I-9
Q655	I-9
Q750	C-5
Q751	B-4
Q852	H-10

7-8. SCHEMATIC DIAGRAM – BASE MAIN Section (2/3) – • See page 34 for Waveform. • See page 53 for IC Block Diagrams.

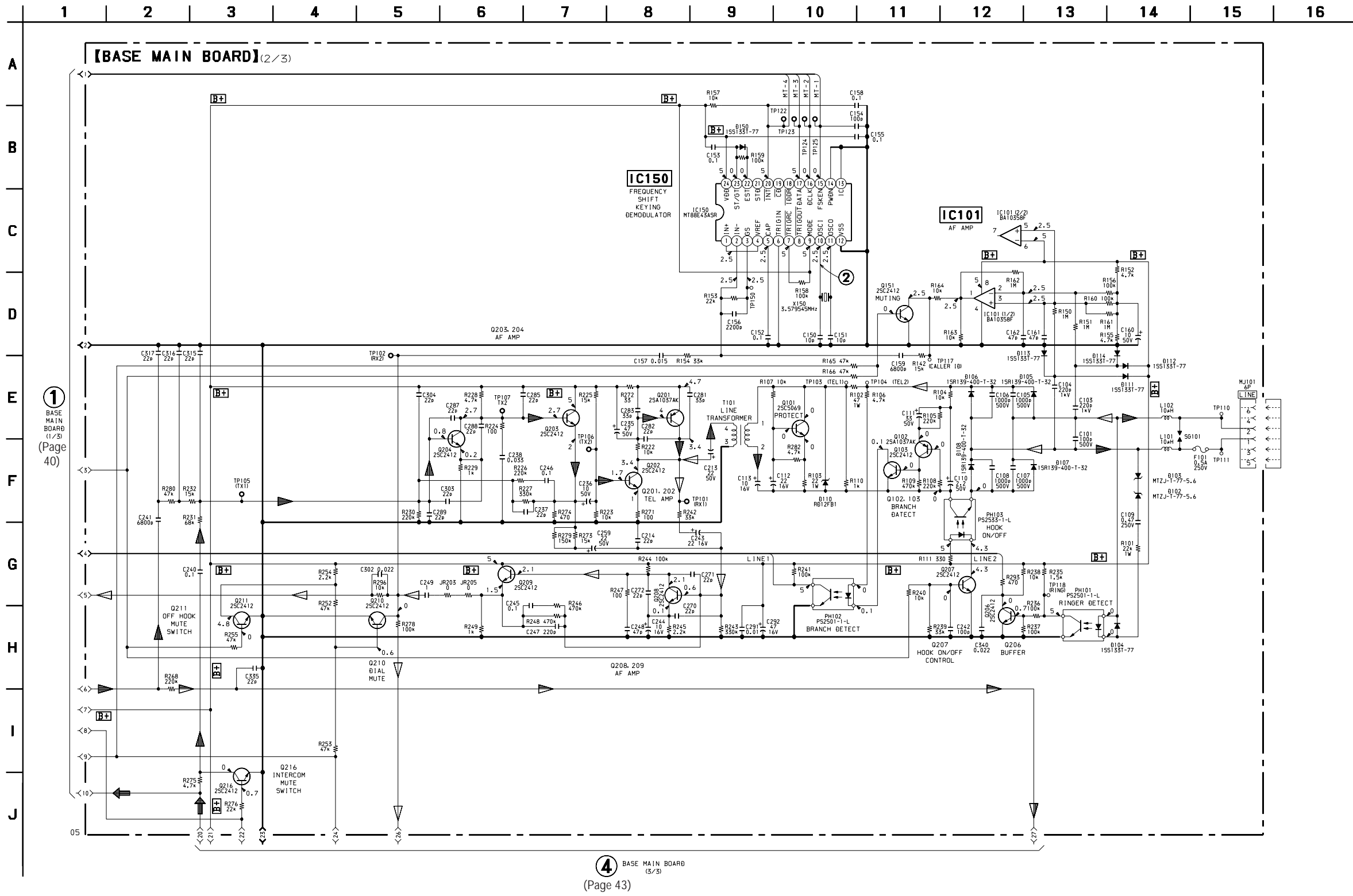

7-9. SCHEMATIC DIAGRAM – BASE MAIN Section (3/3) – • See page 53 for IC Block Diagrams.

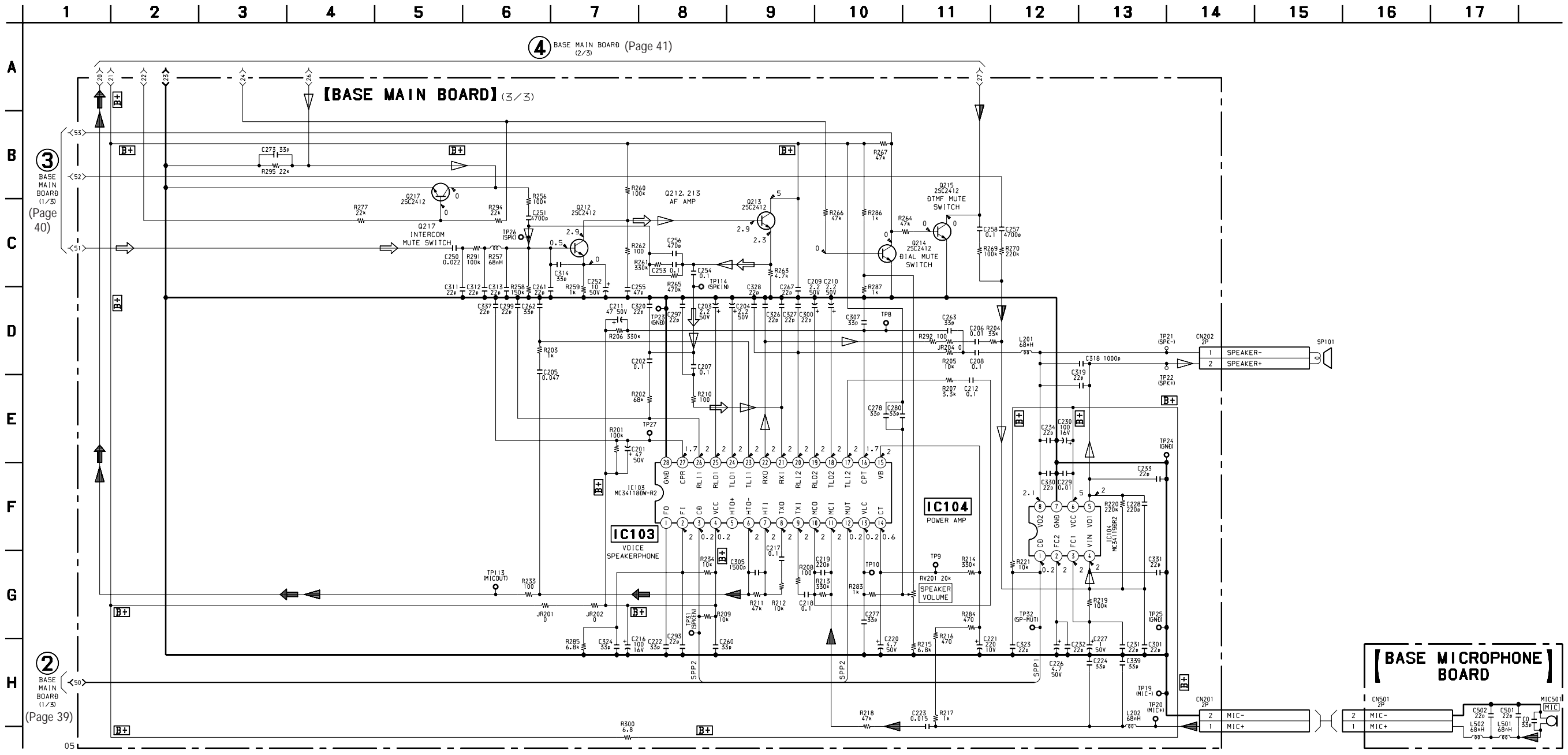

7-10. PRINTED WIRING BOARD – BASE KEY Section –

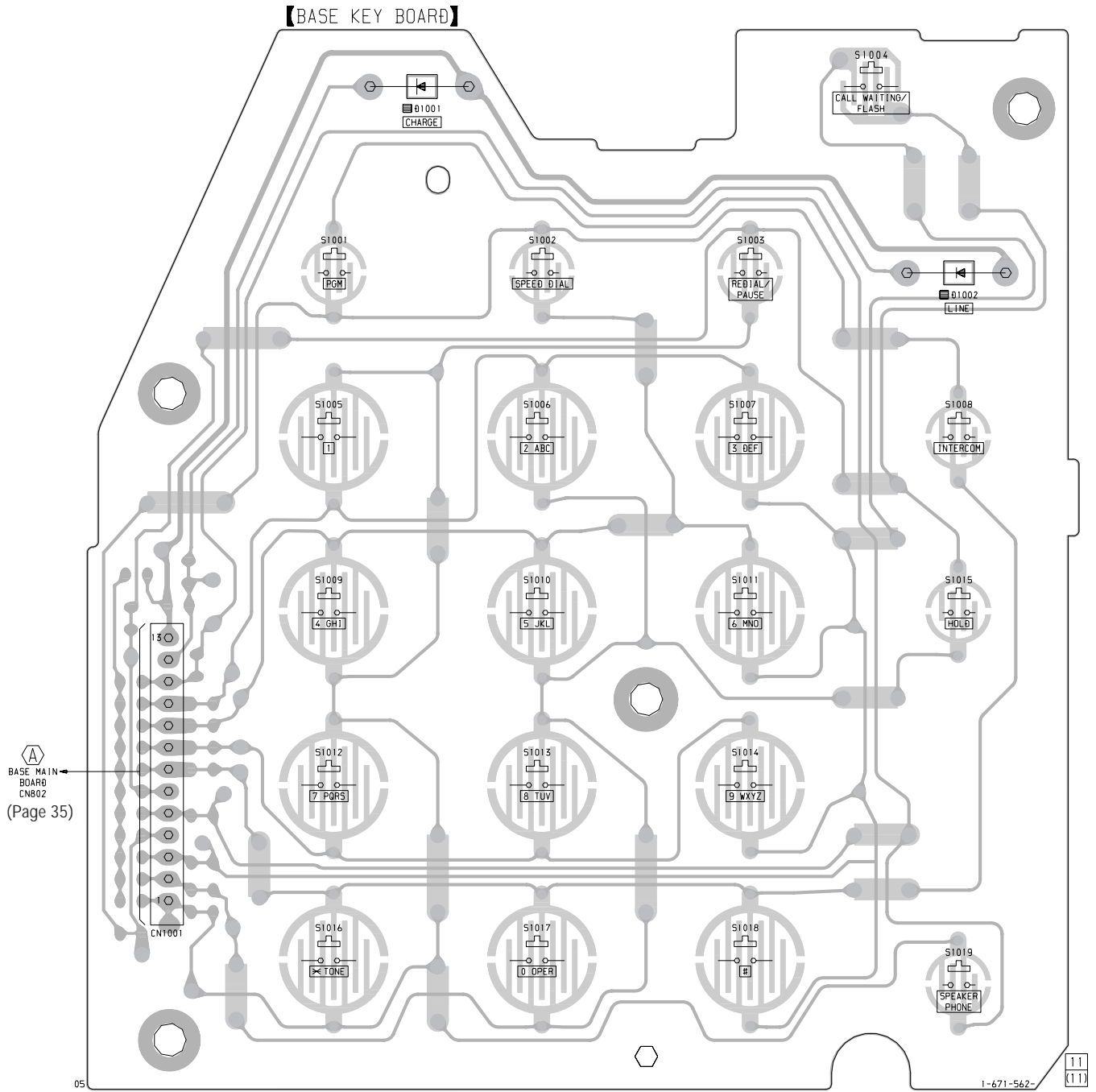

Note

- : Pattern of the side which is seen. (Carbon pattern)
- : Pattern from the side which enables seeing.

7-11. SCHEMATIC DIAGRAM – BASE KEY Section –

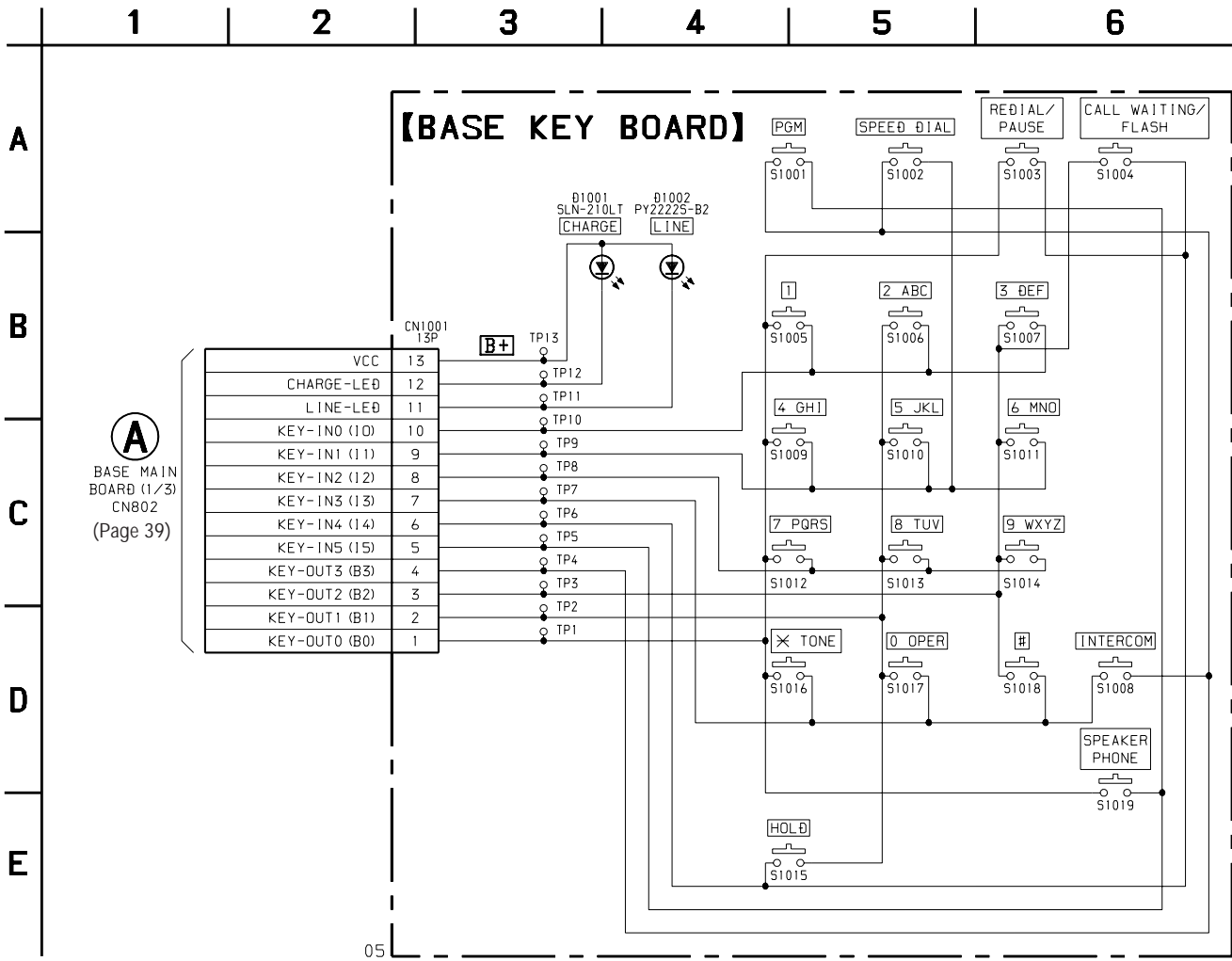

7-12. PRINTED WIRING BOARD – BASE LCD Section –

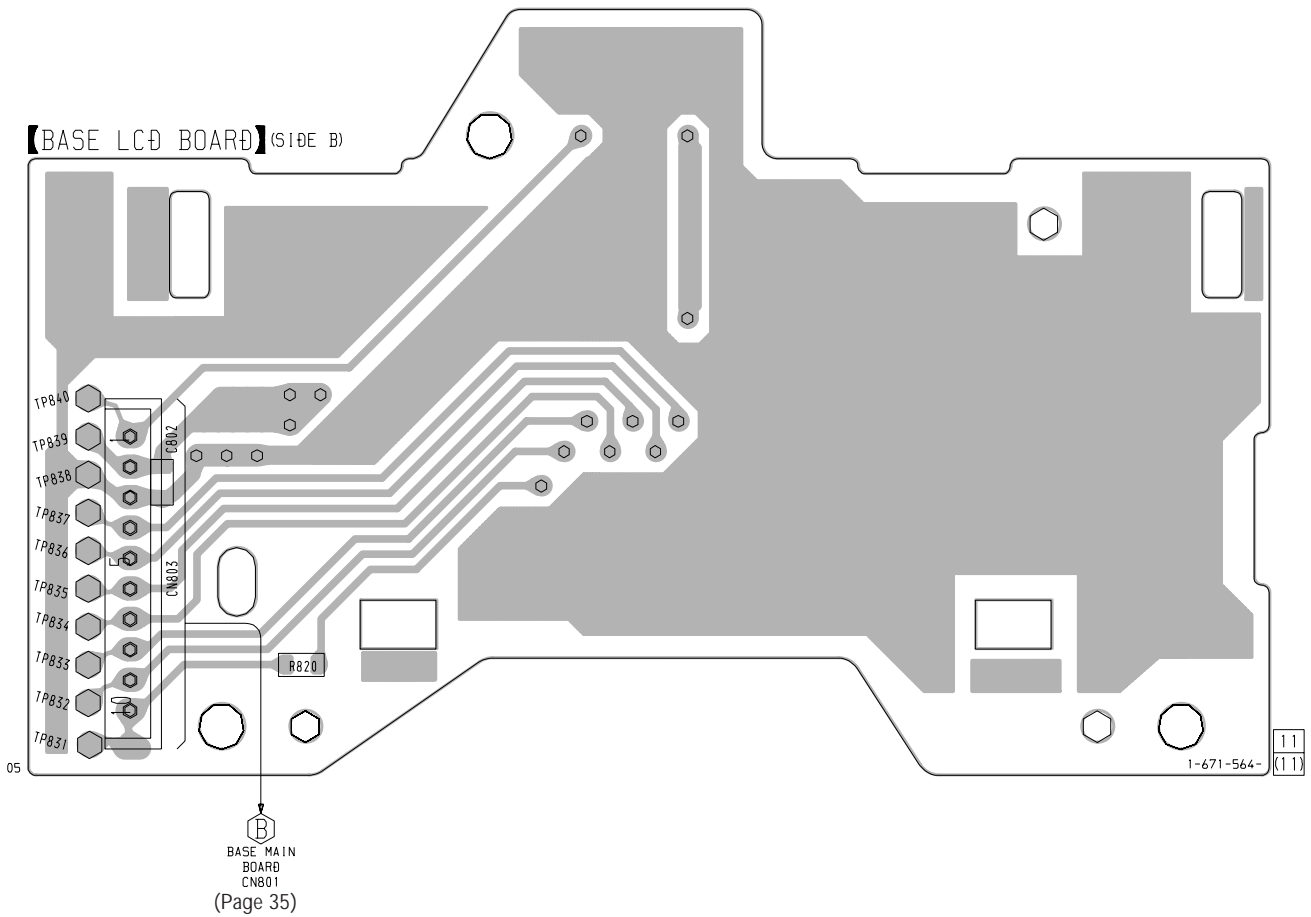
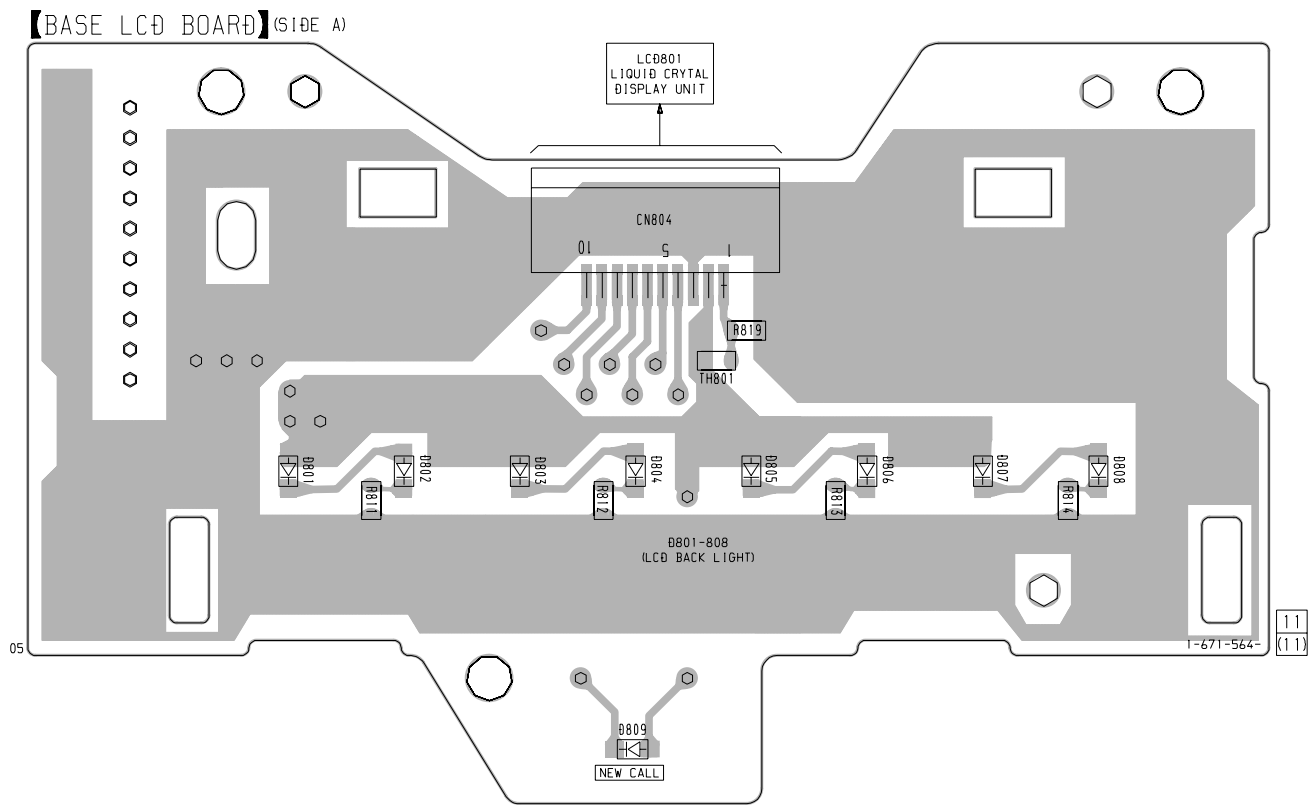

7-13. SCHEMATIC DIAGRAM – BASE LCD Section –

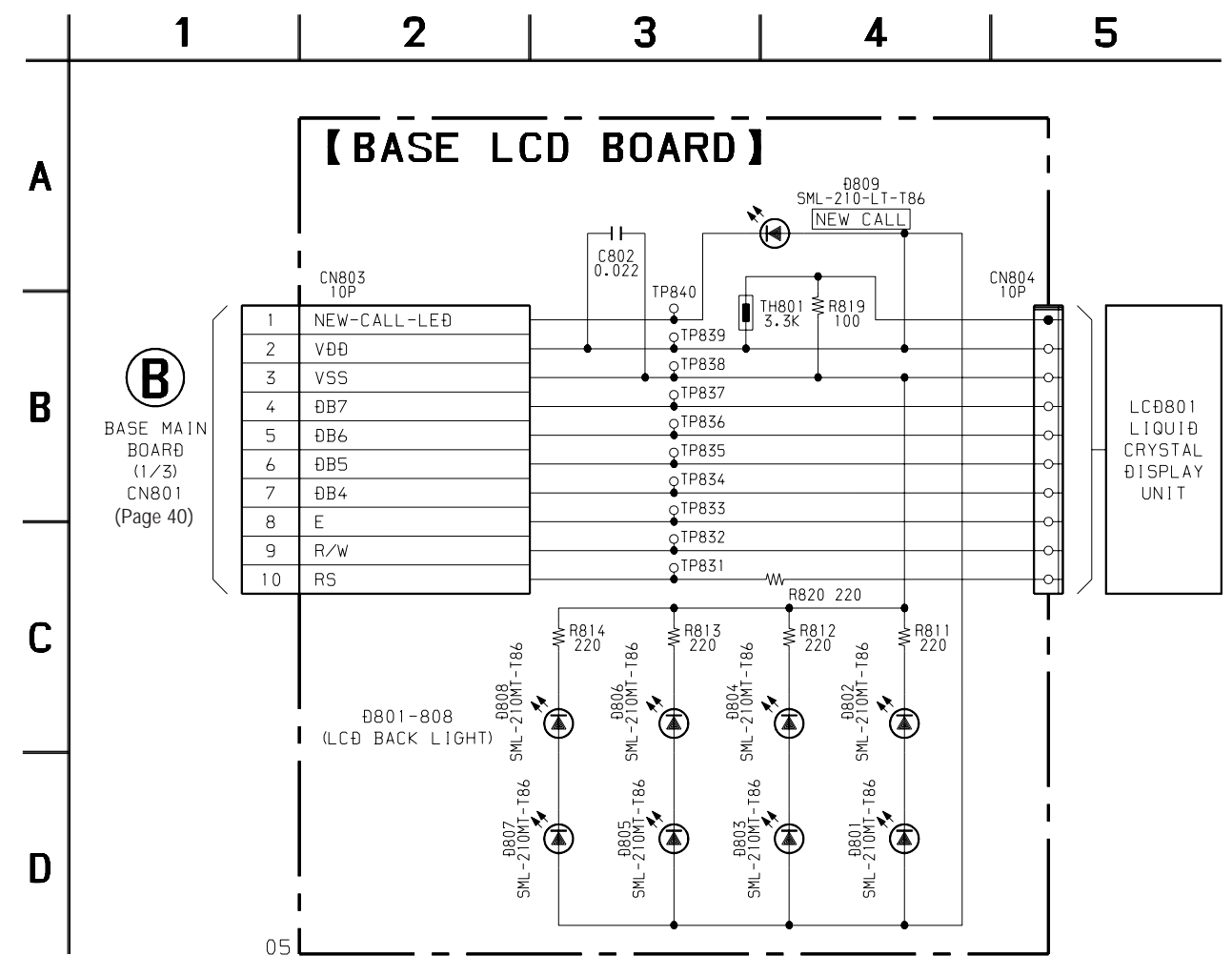

7-14. PRINTED WIRING BOARD – HAND MAIN Section –

• Semiconductor Location (SIDE A)

Ref. No.	Location
D502	B-3
D503	B-3
Q501	A-3
Q504	C-2
Q505	C-2

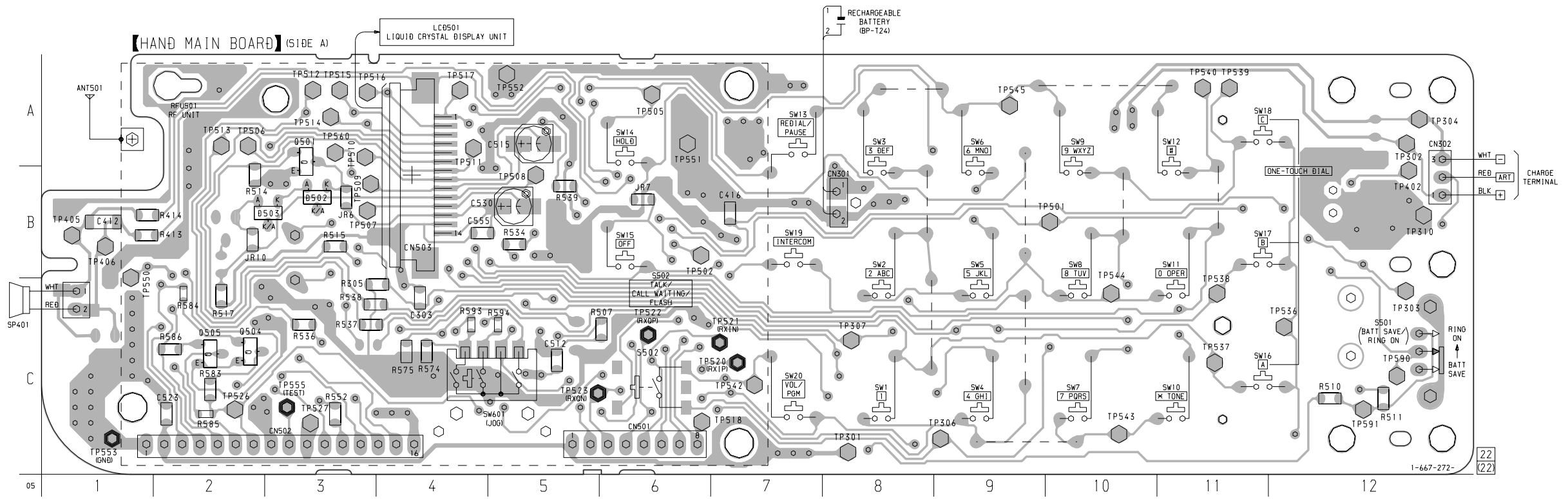

Note:
 • - - - - : carbon pattern.

• Semiconductor Location (SIDE B)

Ref. No.	Location
D301	B-11
D302	B-10
D303	A-11
D304	A-10
D305	B-10
D306	A-9
D401	C-12
D402	C-12
D505	B-11
IC301	B-9
IC401	A-6
IC501	C-5
IC502	C-2
Q1	A-11
Q301	B-9
Q302	B-9
Q303	C-8
Q502	C-12
Q503	B-11

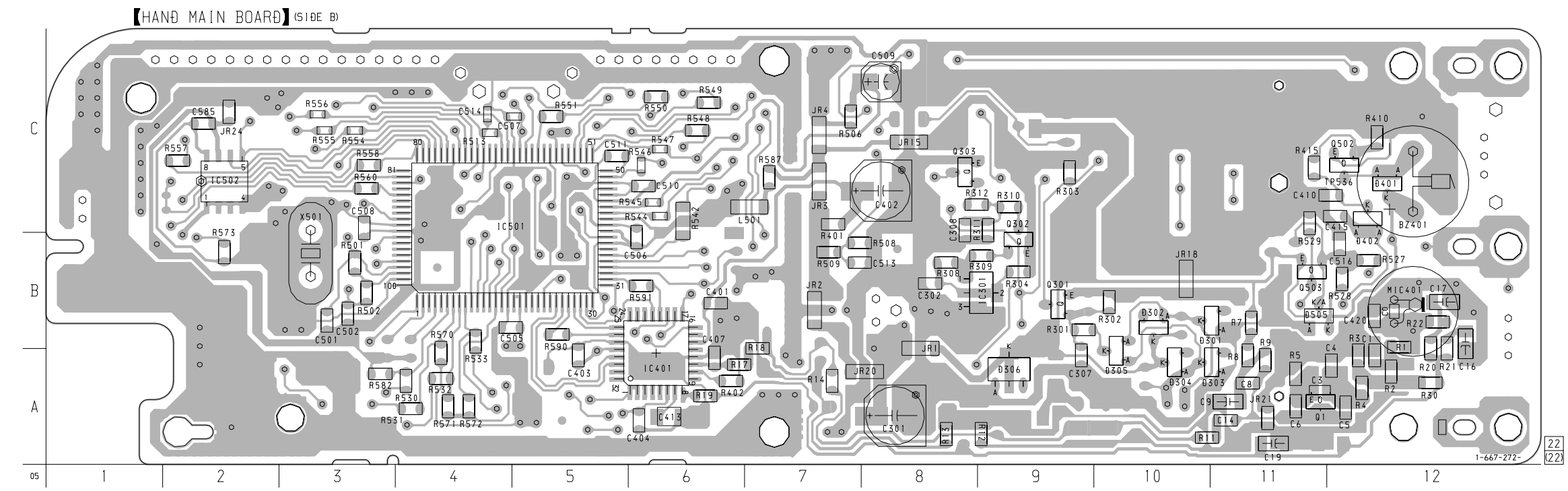

7-15. SCHEMATIC DIAGRAM – HAND MAIN Section – • See page 34 for Waveform. • See page 54 for IC Block Diagrams.

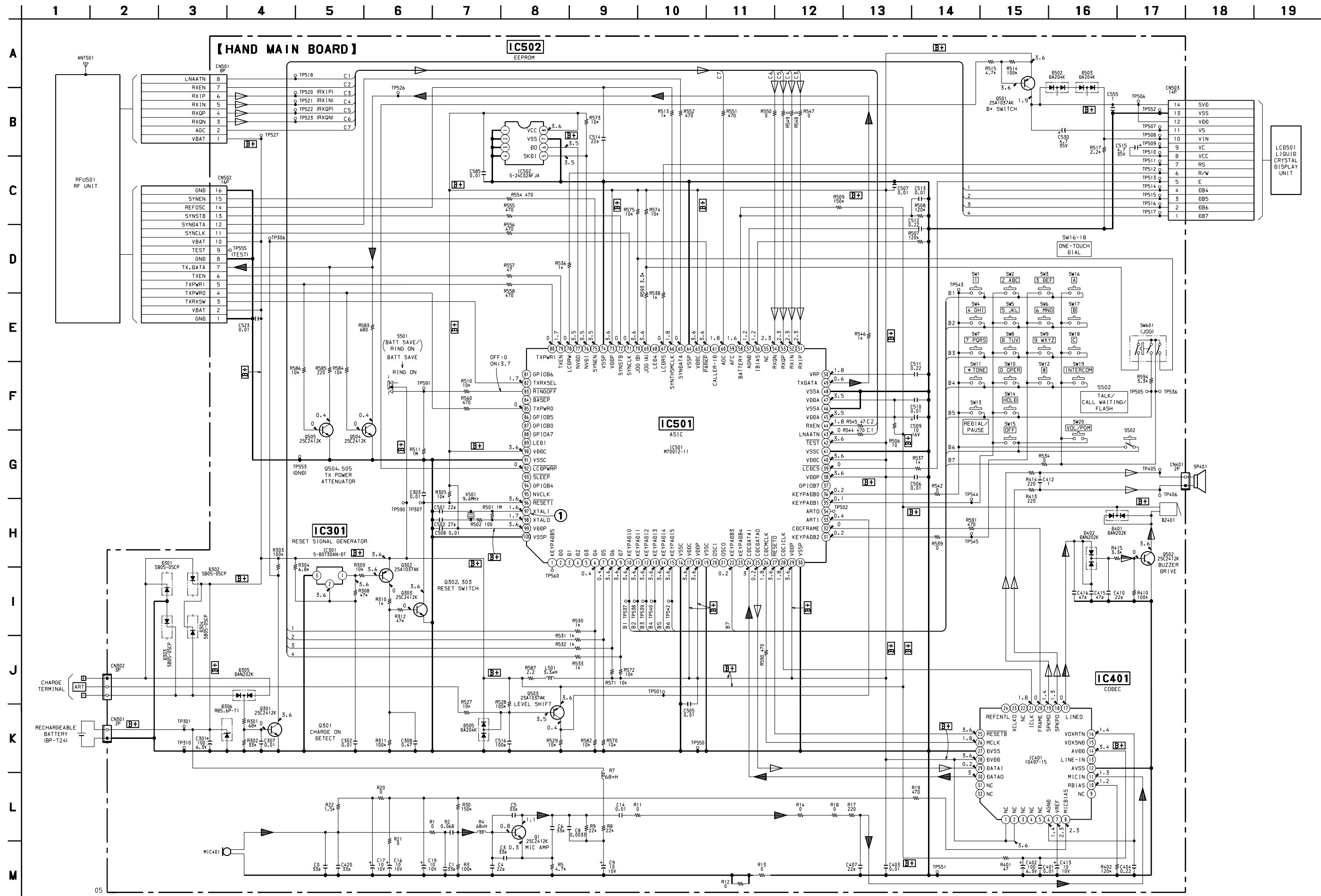

• IC Block Diagrams

IC103 MC34118DW (BASE MAIN BOARD)

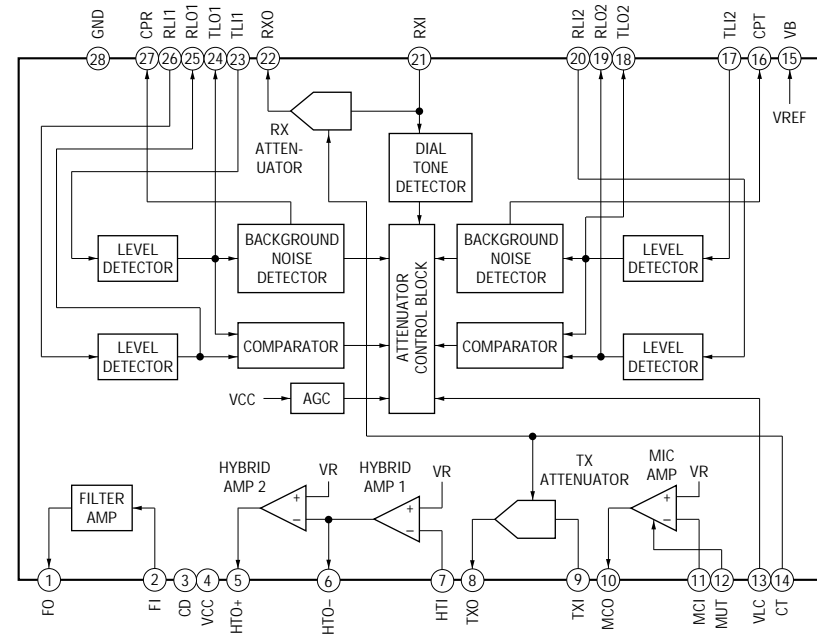

IC104 MC34119DR2 (BASE MAIN BOARD)

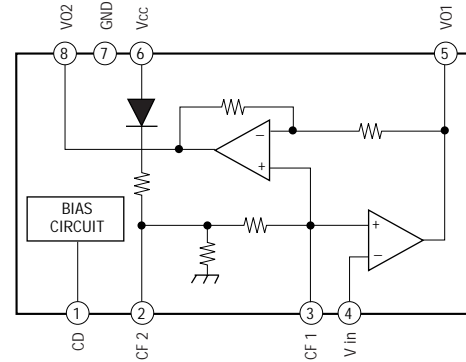

IC401 10497-15 (HAND MAIN BOARD)
IC701 10497-15 (BASE MAIN BOARD)

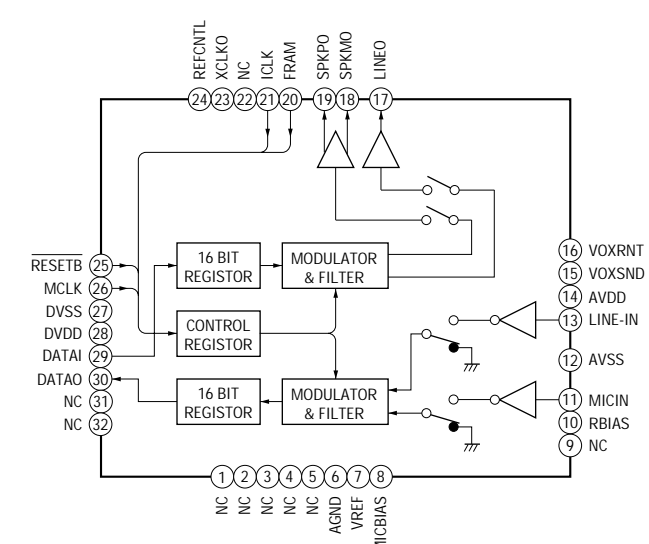

IC502 S-24C16AFJ-TB (HAND MAIN BOARD)
IC951 S-24C02AFJ-TB (BASE MAIN BOARD)

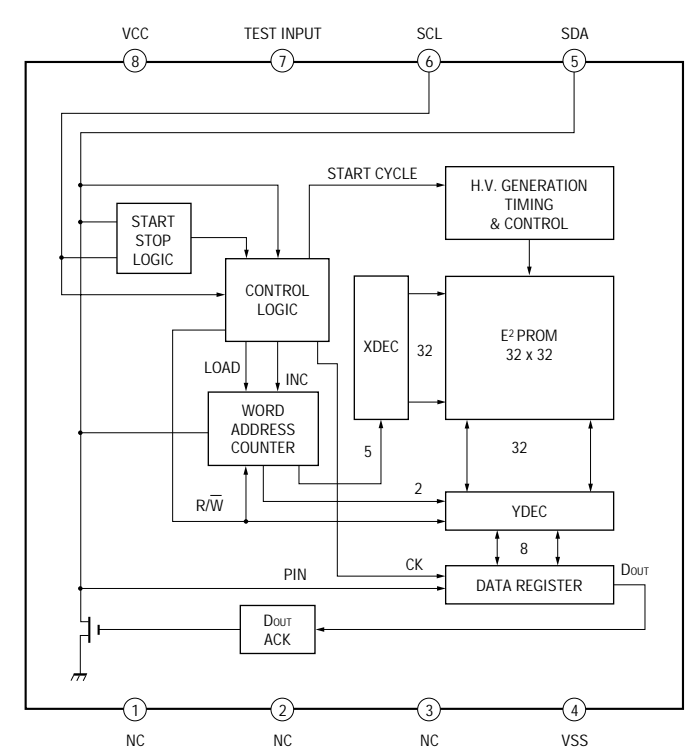

IC150 MT88E43 (BASE MAIN BOARD)

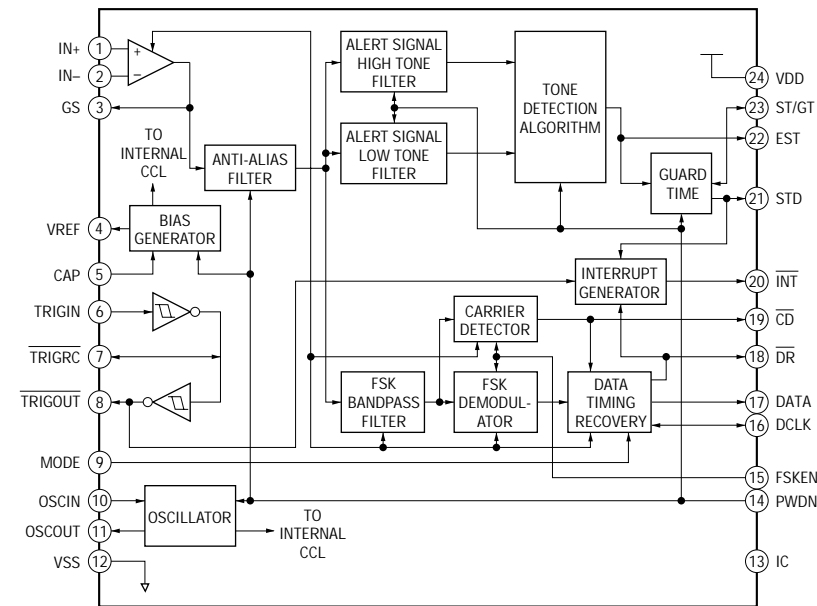

7-16. IC PIN FUNCTION DESCRIPTION

• HAND MAIN BOARD IC501 M70012-11 (ASIC)

Pin No.	Pin Name	I/O	Function
1	KEYPADB5	O	Key output terminal Not used (open)
2	D0	I	Selection input of the model Not used (open)
3, 4	D1, D2	I/O	Not used (open)
5	D3	I	Selection input of the test mode Not used (open)
6 to 9	D4 to D7	O	Serial data output to the liquid crystal display unit (LCD501)
10 to 15	KEYPADI0 to KEYPADI5	I	Key return signal input from the key matrix “L” input when key pressing
16	VSSC	—	Ground terminal (for core)
17	VDDC	—	Power supply terminal (+5V) (for core)
18	VDDP	—	Power supply terminal (+5V) (for pad)
19	VSSC	—	Ground terminal (for core)
20	OSCI	I	Sub system clock input terminal (32.768 kHz) Not used (open)
21	OSCO	O	Sub system clock output terminal (32.768 kHz) Not used (open)
22	KEYPADB3	O	Key send signal output to the key matrix
23	KEYPADB4	O	Key output terminal Not used (open)
24	CDCDATAI	I	Transmit data input from the CODEC (IC401)
25	CDCDATAO	O	Receive data output to the CODEC (IC401)
26	CDCMCLK	O	Master clock signal output to the CODEC (IC401)
27	RESETO	O	Reset signal output to the CODEC (IC401) “L”: reset
28	CDCICLK	O	Interface clock signal output to the CODEC (IC401)
29	VDDP	—	Power supply terminal (+5V) (for pad)
30	VSSP	—	Ground terminal (for pad)
31	KEYPADB2	O	Key send signal output to the key matrix
32	CDCFRAME	O	Frame output to the CODEC (IC401)
33	ARTI	I	ART input from the base unit
34	ARTO	O	ART output terminal Not used (open)
35, 36	KEYPADB1, KEYPADB0	O	Key send signal output to the key matrix
37	GPIOB7	O	Not used (open)
38	VDDP	—	Power supply terminal (+5V) (for pad)
39	LCDCS	O	Chip select signal output to the liquid crystal display unit (LCD501) “L” active
40	VDDC	—	Power supply terminal (+5V) (for core)
41	VSSC	—	Ground terminal (for core)
42	TEST	I	Setting terminal for the test mode “L”: test mode Normally: fixed at “H”
43	LNAATN	O	LNA gain selection signal output to the RF unit “H”: low gain
44	RXEN	O	RX system enable signal output to the RF unit “H”: enable
45	VDDA	—	Power supply terminal (+5V) (for analog)
46	VSSA	—	Ground terminal (for analog)
47	VDDA	—	Power supply terminal (+5V) (for analog)
48	VSSA	—	Ground terminal (for analog)
49	TXDATA	O	Transmit data output to the RF unit
50	VRP	O	Analog reference voltage output terminal
51	RXIP	I	Receive data (I positive) input from the RF unit
52	RXIN	I	Receive data (I negative) input from the RF unit

Pin No.	Pin Name	I/O	Function
53	RXQP	I	Receive data (Q positive) input from the RF unit
54	RXQN	I	Receive data (Q negative) input from the RF unit
55	NC	—	Not used (open)
56	IBIAS	I	Analog bias input terminal
57	AGND	—	Analog ground terminal
58	BATTERY	I	Battery voltage detection input terminal
59	AFC	O	Not used (open)
60	AGC	O	Auto gain control signal output to the RF unit
61	CALLER-ID	O	Not used (open)
62	$\overline{\text{PARKP}}$	I	Charge detection input terminal “L”: charge on
63	VDDC	—	Power supply terminal (+5V) (for core)
64	VSSP	—	Ground terminal (for pad)
65	SYNDATA	O	Synthesizer data output to the RF unit
66	SYNTH5MCLK	O	Synthesizer reference oscillator output to the RF unit (9.62 MHz)
67	LCDRS	O	Register selection signal output to the liquid crystal display unit (LCD501) “L”: instruction register, “H”: data register
68	LED4	O	LED drive signal output terminal “L”: LED on Not used (open)
69	JOG (A)	I	Jog dial pulse input of the rotary encoder (SW601) (A phase input)
70	JOG (B)	I	Jog dial pulse input of the rotary encoder (SW601) (B phase input)
71	SYNCLK	O	Synthesizer clock signal output to the RF unit
72	SYNSTB	O	Synthesizer strobe signal output to the RF unit
73	VDDP	—	Power supply terminal (+5V) (for pad)
74	VSSP	—	Ground terminal (for pad)
75	SYNEN	O	Synthesizer power control signal output to the RF unit “H”: enable
76	NVDI	I/O	Two-way data bus with the EEPROM (IC502)
77	NVDO	O	Clock signal output to the EEPROM (IC502)
78	LCDRW	O	Data read/write selection signal output to the liquid crystal display unit (LCD501) “L”: data write, “H”: data read
79	TXEN	O	TX system enable signal output to the RF unit “H”: enable
80	TXPWR1	O	PA power selection signal output to the RF unit
81	GPIOB6	O	Not used (open)
82	TXRXSEL	O	TX/RX selection signal output to the RF unit “L”: RX, “H”: TX
83	$\overline{\text{RINGOFF}}$	I	BATT SAVE/RING ON switch (S501) input terminal “L”: ringer off (battery save), “H”: ringer on
84	$\overline{\text{BASEP}}$	I	Setting terminal for the base/handset selection “L”: base unit, “H”: handset unit (CMOS receiver with pull-up)
85	TXPWR0	O	PA power selection signal output to the RF unit
86, 87	GPIOB5, GPIOB0	O	Not used (open)
88	GPIOA7	O	Muting control signal output for the speaker amplifier “H” active Not used (open)
89	LED1	O	LED drive signal output terminal “L”: LED on Not used (open)
90	VDDC	—	Power supply terminal (+5V) (for core)
91	VSSC	—	Ground terminal (for core)
92	$\overline{\text{LCDPWRP}}$	O	Power on/off control signal output for the liquid crystal display unit (LCD501) “L”: power on, “H”: power off
93	$\overline{\text{SLEEP}}$	O	Not used (open)
94	GPIOB4	O	Not used (open)

Pin No.	Pin Name	I/O	Function
95	NVCLK	O	Not used (open)
96	$\overline{\text{RESETI}}$	I	System reset signal input from the reset signal generator (IC301) “L”: reset For several hundreds msec. after the power supply rises, “L” is input, then it changes to “H”
97	XTALI	I	Main system clock input terminal (9.6 MHz)
98	XTALO	O	Main system clock output terminal (9.6 MHz)
99	VDDP	—	Power supply terminal (+5V) (for pad)
100	VSSP	—	Ground terminal (for pad)

• BASE MAIN BOARD IC751 M70012-11 (ASIC)

Pin No.	Pin Name	I/O	Function
1	KEY-OUT5	O	Key output terminal Not used (open)
2 to 5	D0 to D3	O	Not used (open)
6 to 9	D4 to D7	O	Serial data output to the liquid crystal display unit (LCD801)
10 to 15	KEY-IN0 to KEY-IN5	I	Key return signal input from the key matrix “L” input when key pressing
16	VSSC	—	Ground terminal (for core)
17	VDDC	—	Power supply terminal (+5V) (for core)
18	VDDP	—	Power supply terminal (+5V) (for pad)
19	VSSC	—	Ground terminal (for core)
20	INTC & HOLD CTRL	O	Intercom and hold control signal output terminal “H”: intercom and hold status, Others: “L”
21	RING MODE ON/OFF	I	RINGER switch (SW952) input terminal “L”: ringer off, “H”: ringer on
22	KEY-OUT3	O	Key send signal output to the key matrix
23	KEY-OUT4	O	Key output terminal Not used (open)
24	CDCDATAI	I	Transmit data input from the CODEC (IC701)
25	CDCDATAO	O	Receive data output to the CODEC (IC701)
26	CDCMCLK	O	Master clock signal output to the CODEC (IC701)
27	$\overline{\text{RESETO}}$	O	Reset signal output to the CODEC (IC701) “L”: reset
28	CDCICLK	O	Interface clock signal output to the CODEC (IC701)
29	VDDP	—	Power supply terminal (+5V) (for pad)
30	VSSP	—	Ground terminal (for pad)
31	KEY-OUT2	O	Key send signal output to the key matrix
32	CDCFRAME	O	Frame output to the CODEC (IC701)
33	ARTI	I	ART input terminal Not used (fixed at “H”)
34	ARTO	O	ART output to the handset unit
35, 36	KEY-OUT1, KEY-OUT0	O	Key send signal output to the key matrix
37	OFFHOOK	O	Hook on/off control signal output terminal “L”: on hook, “H”: off hook
38	VDDP	—	Power supply terminal (+5V) (for pad)
39	$\overline{\text{LCDCS}}$	O	Chip select signal output to the liquid crystal display unit (LCD801)
40	VDDC	—	Power supply terminal (+5V) (for core)
41	VSSC	—	Ground terminal (for core)
42	$\overline{\text{TEST}}$	I	Setting terminal for the test mode “L”: test mode Normally: fixed at “H”
43	LNAATN	O	LNA gain selection signal output to the RF unit “H”: low gain
44	RXEN	O	RX system enable signal output to the RF unit “H”: enable
45	VDDA	—	Power supply terminal (+5V) (for analog)
46	VSSA	—	Ground terminal (for analog)
47	VDDA	—	Power supply terminal (+5V) (for analog)
48	VSSA	—	Ground terminal (for analog)
49	TXDATA	O	Transmit data output to the RF unit
50	VRP	O	Analog reference voltage output terminal
51	RXIP	I	Receive data (I positive) input from the RF unit
52	RXIN	I	Receive data (I negative) input from the RF unit
53	RXQP	I	Receive data (Q positive) input from the RF unit
54	RXQN	I	Receive data (Q negative) input from the RF unit

Pin No.	Pin Name	I/O	Function
55	NC	—	Not used (open)
56	IBIAS	I	Analog bias input terminal
57	AGND	—	Analog ground terminal
58	<u>POWERDOWN</u>	I	Battery voltage detection input terminal “L”: power down
59	AFC (BEEP)	O	Beep tone signal output terminal
60	AGC	O	Auto gain control signal output to the RF unit
61	MT-CLK	O	Caller-ID clock signal (1.2 kHz) output to the MT88E43 (IC150)
62	<u>PARKP</u>	I	Charge detection input terminal “L”: charge on
63	VDDC	—	Power supply terminal (+5V) (for core)
64	VSSP	—	Ground terminal (for pad)
65	SYNDATA	O	Synthesizer data output to the RF unit
66	SYNTH5MCLK	O	Synthesizer reference oscillator output to the RF unit (9.62 MHz)
67	LCD REG-SET	O	Register selection signal output to the liquid crystal display unit (LCD801) “L”: instruction register, “H”: data register
68	<u>LINE-LED</u>	O	LED drive signal output of the LINE LED (D1002) “L”: LED on
69	<u>MT-INT</u>	I	Caller-ID interrupt input from the MT88E43 (IC150) “L” active
70	MT-DATA	I	Caller-ID data input from the MT88E43 (IC150)
71	SYNCLK	O	Synthesizer clock signal output to the RF unit
72	SYNSTB	O	Synthesizer strobe signal output to the RF unit
73	VDDP	—	Power supply terminal (+5V) (for pad)
74	VSSP	—	Ground terminal (for pad)
75	SYNEN	O	Synthesizer power control signal output to the RF unit “H”: enable
76	NVDI	I/O	Two-way data bus with the EEPROM (IC951)
77	NVDO	O	Clock signal output to the EEPROM (IC951)
78	LCD-R/W	O	Data read/write selection signal output to the liquid crystal display unit (LCD801) “L”: data write, “H”: data read
79	TXEN	O	TX system enable signal output to the RF unit “H”: enable
80	TXPWR1	O	PA power selection signal output to the RF unit
81	<u>RINGIN</u>	I	Detection signal input of the ringer coming “L”: ringer coming
82	TXRSEL	O	TX/RX selection signal output to the RF unit “L”: RX, “H”: TX
83	VCHG-MON	I	Battery charge monitor input terminal
84	<u>BASEP</u>	I	Setting terminal for the base/handset selection “L”: base unit, “H”: handset unit (fixed at “L” in this set)
85	TXPWR0	O	PA power selection signal output to the RF unit
86	<u>SPKEN</u>	O	Enable control signal output to the voice speakerphone (IC103) “L”: enable, “H”: CD
87	CHG-HIGH RATE	O	Quick/normal charge selection signal output terminal “H”: normal charge, “L”: quick charge
88	DIALMODE	I	Dial mode switch (SW951) input terminal “L”: pulse, “H”: tone
89	<u>NEW-CALL LED</u>	O	LED drive signal output of the NEW CALL LED (D809) “L”: LED on
90	VDDC	—	Power supply terminal (+5V) (for core)
91	VSSC	—	Ground terminal (for core)
92	<u>SP-MUT</u>	O	Speaker muting on/off control signal output to the power amplifier (IC104) “H”: muting
93	<u>MT-FSK-EN</u>	O	Caller-ID frequency shift keying enable signal output to the MT88E43 (IC150)
94	BRANCH-DET	I	Reserve cancellation detect signal input terminal “H”: cancel status
95	DIALMUT	O	Reception muting during dial transmission “H”: during dial transmission
96	<u>RESETI</u>	I	System reset signal input from the reset signal generator (IC602) “L”: reset For several hundreds msec. after the power supply rises, “L” is input, then it changes to “H”

Pin No.	Pin Name	I/O	Function
97	XTALI	I	Main system clock input terminal (9.6 MHz)
98	XTALO	O	Main system clock output terminal (9.6 MHz)
99	VDDP	—	Power supply terminal (+5V) (for pad)
100	VSSP	—	Ground terminal (for pad)

(2) BASESET SECTION

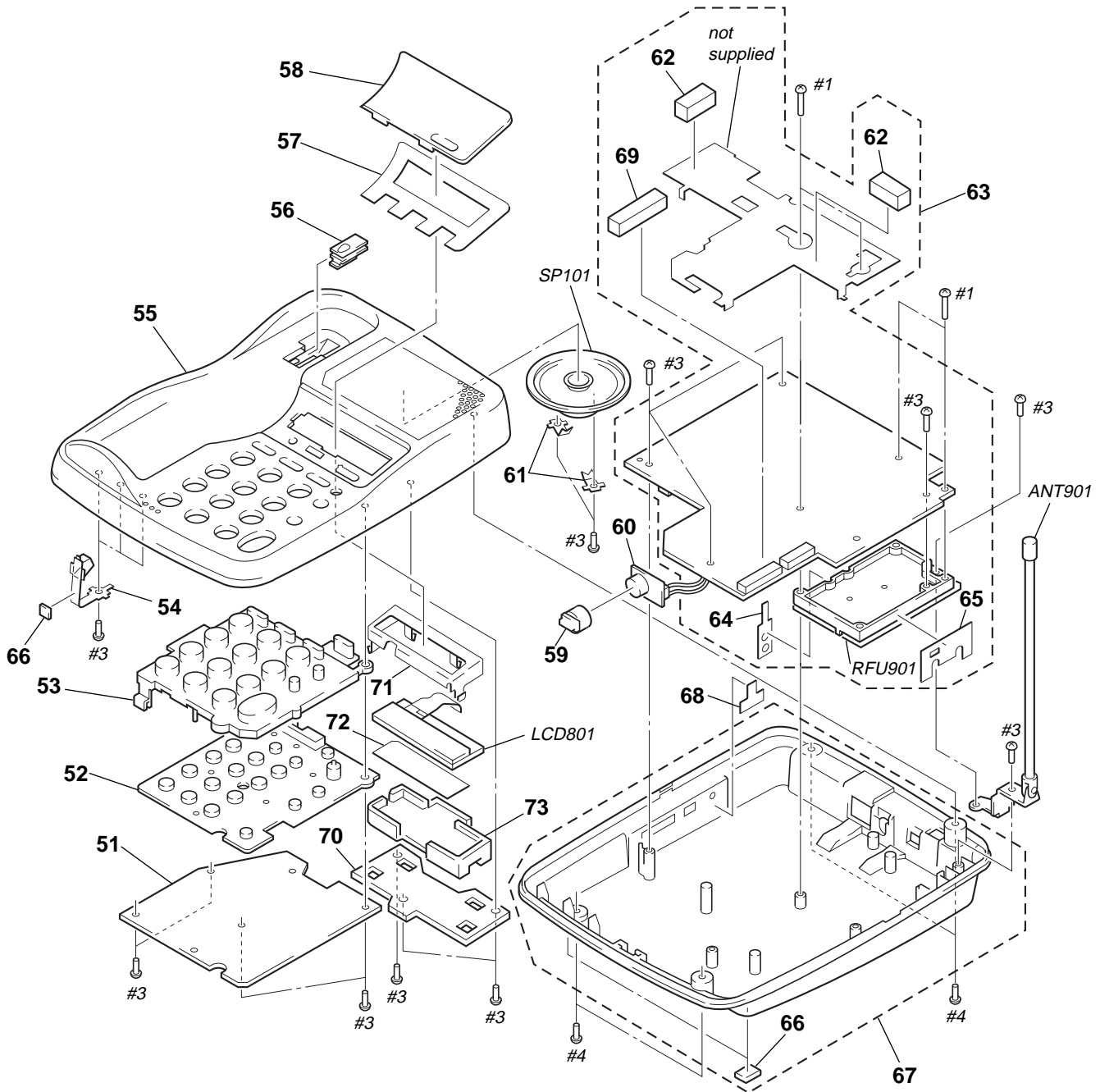

Ref. No.	Part No.	Description	Remark	Ref. No.	Part No.	Description	Remark
* 51	1-671-562-11	BASE KEY BOARD		65	3-030-066-02	SHEET (COPPER LEAF. RF) (C)	
52	1-771-364-11	SWITCH, RUBBER KEY (BASE)		66	3-936-696-21	FOOT, RUBBER	
53	3-024-958-01	BUTTON (12 KEY)		67	X-3375-888-1	CABINET (LOWER) ASSY	
54	3-023-909-01	TERMINAL (CHARGE B/S)		68	3-026-909-01	SHEET (RESET BUTTON)	
55	3-024-956-01	CABINET (UPPER)		* 69	3-032-727-01	CUSHION (for PWB) B	
56	3-024-955-01	HOLDER (HAND SET)		* 70	1-671-564-11	BASE LCD BOARD	
57	3-024-963-01	SHEET (LCD), ADHESIVE		71	3-024-961-01	FRAME (LCD)	
58	3-024-959-11	PANEL (LCD)		72	3-026-188-01	ILLUMINATOR (SS965)	
59	3-910-956-01	HOLDER (MIC)		73	3-024-960-01	HOLDER (LCD)	
* 60	1-671-565-11	BASE MICROPHONE BOARD		ANT901	1-501-998-11	ANTENNA, ROD	
61	3-015-461-01	BRACKET (SP STOPPER)		LCD801	1-475-724-11	LCD UNIT	
62	3-018-253-01	CUSHION (BATTERY)		RFU901	1-475-890-11	RF UNIT	
* 63	A-3622-211-A	BASE MAIN BOARD, COMPLETE		SP101	1-505-802-11	SPEAKER (5.7cm)	
64	3-029-168-01	SHEET (COPPER LEAF. RF) (B)					

SECTION 9 ELECTRICAL PARTS LIST

BASE KEY

BASE LCD

BASE MAIN

NOTE:

- Due to standardization, replacements in the parts list may be different from the parts specified in the diagrams or the components used on the set.
- -XX and -X mean standardized parts, so they may have some difference from the original one.
- RESISTORS
All resistors are in ohms.
METAL: Metal-film resistor.
METAL OXIDE: Metal oxide-film resistor.
F: nonflammable

- Items marked “*” are not stocked since they are seldom required for routine service. Some delay should be anticipated when ordering these items.
- SEMICONDUCTORS
In each case, u: μ , for example:
uA. . : μ A. . uPA. . : μ PA. .
uPB. . : μ PB. . uPC. . : μ PC. .
uPD. . : μ PD. .
- CAPACITORS
uF: μ F
- COILS
uH: μ H

The components identified by mark Δ or dotted line with mark Δ are critical for safety. Replace only with part number specified.

Les composants identifiés par une marque Δ sont critiques pour la sécurité. Ne les remplacer que par une pièce portant le numéro spécifié.

When indicating parts by reference number, please include the board.

Ref. No.	Part No.	Description	Remark	Ref. No.	Part No.	Description	Remark
*	1-671-562-11	BASE KEY BOARD *****		*	A-3622-211-A	BASE MAIN BOARD, COMPLETE *****	
		< LED >			3-018-253-01	CUSHION (BATTERY)	
D1001	8-719-946-48	LED SLN210LT (CHARGE)			3-029-168-01	SHEET (COPPER LEAF.RF) (B)	
D1002	8-719-055-05	LED PY2222S-B2 (LINE)			3-030-066-02	SHEET (COPPER LEAF RF) (C)	
*****				*	3-032-727-01	CUSHION (for PWB) B	
		< CAPACITOR >			7-685-134-19	SCREW +BTP 2.6X8 TYPE2 N-S	
*	1-671-564-11	BASE LCD BOARD *****					
		< CAPACITOR >					
C802	1-163-033-00	CERAMIC CHIP 0.022uF	50V		C101	1-162-117-00 CERAMIC 100PF 10% 500V	
		< CONNECTOR >			C103	1-107-423-11 CERAMIC 220PF 10% 1KV	
CN804	1-568-235-21	CONNECTOR, FPC (1.0MM)(ZIF)10P			C104	1-107-423-11 CERAMIC 220PF 10% 1KV	
		< LED >			C105	1-162-318-11 CERAMIC 0.001uF 10% 500V	
D801	8-719-060-99	LED SML-210MT-T86 (LCD BACK LIGHT)			C106	1-162-318-11 CERAMIC 0.001uF 10% 500V	
D802	8-719-060-99	LED SML-210MT-T86 (LCD BACK LIGHT)			C107	1-162-318-11 CERAMIC 0.001uF 10% 500V	
D803	8-719-060-99	LED SML-210MT-T86 (LCD BACK LIGHT)			C108	1-162-318-11 CERAMIC 0.001uF 10% 500V	
D804	8-719-060-99	LED SML-210MT-T86 (LCD BACK LIGHT)			C109	1-136-193-11 FILM 0.47uF 10% 250V	
D805	8-719-060-99	LED SML-210MT-T86 (LCD BACK LIGHT)			C110	1-126-961-11 ELECT 2.2uF 20% 50V	
D806	8-719-060-99	LED SML-210MT-T86 (LCD BACK LIGHT)			C111	1-126-966-11 ELECT 33uF 20% 50V	
D807	8-719-060-99	LED SML-210MT-T86 (LCD BACK LIGHT)			C112	1-124-234-00 ELECT 22uF 20% 16V	
D808	8-719-060-99	LED SML-210MT-T86 (LCD BACK LIGHT)			C113	1-126-157-11 ELECT 10uF 20% 16V	
D809	8-719-059-96	LED SML-210LT-T86 (NEW CALL)			C150	1-163-227-11 CERAMIC CHIP 10PF 0.5PF 50V	
		< LIQUID CRYSTAL DISPLAY >			C151	1-163-227-11 CERAMIC CHIP 10PF 0.5PF 50V	
LCD801	1-475-724-11	LCD UNIT			C152	1-163-038-00 CERAMIC CHIP 0.1uF 25V	
		< RESISTOR >			C153	1-163-038-00 CERAMIC CHIP 0.1uF 25V	
R811	1-216-033-00	METAL CHIP 220 5% 1/10W			C154	1-163-251-11 CERAMIC CHIP 100PF 5% 50V	
R812	1-216-033-00	METAL CHIP 220 5% 1/10W			C155	1-163-038-00 CERAMIC CHIP 0.1uF 25V	
R813	1-216-033-00	METAL CHIP 220 5% 1/10W			C156	1-164-161-11 CERAMIC CHIP 0.0022uF 10% 100V	
R814	1-216-033-00	METAL CHIP 220 5% 1/10W			C157	1-163-023-00 CERAMIC CHIP 0.015uF 5% 50V	
R819	1-216-025-00	RES,CHIP 100 5% 1/10W			C158	1-163-038-00 CERAMIC CHIP 0.1uF 25V	
R820	1-216-033-00	METAL CHIP 220 5% 1/10W			C159	1-163-019-00 CERAMIC CHIP 0.0068uF 10% 50V	
		< THERMISTOR >			C160	1-126-964-11 ELECT 10uF 20% 50V	
TH801	1-809-308-21	THERMISTOR (CHIP)			C161	1-163-243-11 CERAMIC CHIP 47PF 5% 50V	
*****					C162	1-163-243-11 CERAMIC CHIP 47PF 5% 50V	
					C201	1-126-967-11 ELECT 47uF 20% 50V	
					C202	1-163-038-00 CERAMIC CHIP 0.1uF 25V	
					C203	1-126-961-11 ELECT 2.2uF 20% 50V	
					C204	1-126-961-11 ELECT 2.2uF 20% 50V	
					C205	1-163-035-00 CERAMIC CHIP 0.047uF 50V	
					C206	1-163-021-11 CERAMIC CHIP 0.01uF 10% 50V	
					C207	1-164-004-11 CERAMIC CHIP 0.1uF 10% 25V	
					C208	1-164-004-11 CERAMIC CHIP 0.1uF 10% 25V	
					C209	1-126-961-11 ELECT 2.2uF 20% 50V	
					C210	1-126-961-11 ELECT 2.2uF 20% 50V	

BASE MAIN

Ref. No.	Part No.	Description	Remark	Ref. No.	Part No.	Description	Remark
C211	1-126-967-11	ELECT	47uF 20%	50V	C280	1-163-239-11	CERAMIC CHIP 33PF 5% 50V
C212	1-163-038-00	CERAMIC CHIP	0.1uF	25V	C281	1-163-239-11	CERAMIC CHIP 33PF 5% 50V
C213	1-126-965-11	ELECT	22uF 20%	50V	C282	1-163-235-11	CERAMIC CHIP 22PF 5% 50V
C214	1-163-165-00	CERAMIC CHIP	22PF	5% 50V	C283	1-163-239-11	CERAMIC CHIP 33PF 5% 50V
C216	1-126-933-11	ELECT	100uF	20% 16V	C285	1-163-235-11	CERAMIC CHIP 22PF 5% 50V
C217	1-163-038-00	CERAMIC CHIP	0.1uF	25V	C287	1-163-235-11	CERAMIC CHIP 22PF 5% 50V
C218	1-164-004-11	CERAMIC CHIP	0.1uF	10% 25V	C288	1-163-235-11	CERAMIC CHIP 22PF 5% 50V
C219	1-163-001-11	CERAMIC CHIP	220PF	10% 50V	C289	1-163-235-11	CERAMIC CHIP 22PF 5% 50V
C220	1-126-963-11	ELECT	4.7uF	20% 50V	C291	1-163-031-11	CERAMIC CHIP 0.01uF 50V
C221	1-126-934-11	ELECT	220uF	20% 10V	C292	1-124-589-11	ELECT 47uF 20% 16V
C222	1-163-169-00	CERAMIC CHIP	33PF	5% 50V	C293	1-163-239-11	CERAMIC CHIP 33PF 5% 50V
C223	1-163-023-00	CERAMIC CHIP	0.015uF	5% 50V	C297	1-163-235-11	CERAMIC CHIP 22PF 5% 50V
C224	1-163-239-11	CERAMIC CHIP	33PF	5% 50V	C299	1-163-235-11	CERAMIC CHIP 22PF 5% 50V
C226	1-126-963-11	ELECT	4.7uF	20% 50V	C300	1-163-235-11	CERAMIC CHIP 22PF 5% 50V
C227	1-126-960-11	ELECT	1uF	20% 50V	C301	1-163-235-11	CERAMIC CHIP 22PF 5% 50V
C228	1-163-001-11	CERAMIC CHIP	220PF	10% 50V	C302	1-163-037-11	CERAMIC CHIP 0.022uF 10% 25V
C229	1-163-021-11	CERAMIC CHIP	0.01uF	10% 50V	C303	1-163-235-11	CERAMIC CHIP 22PF 5% 50V
C230	1-126-933-11	ELECT	100uF	20% 16V	C304	1-163-235-11	CERAMIC CHIP 22PF 5% 50V
C231	1-163-235-11	CERAMIC CHIP	22PF	5% 50V	C305	1-163-011-11	CERAMIC CHIP 0.0015uF 10% 50V
C232	1-163-235-11	CERAMIC CHIP	22PF	5% 50V	C307	1-163-239-11	CERAMIC CHIP 33PF 5% 50V
C233	1-163-235-11	CERAMIC CHIP	22PF	5% 50V	C309	1-163-235-11	CERAMIC CHIP 22PF 5% 50V
C234	1-163-235-11	CERAMIC CHIP	22PF	5% 50V	C310	1-163-235-11	CERAMIC CHIP 22PF 5% 50V
C235	1-126-967-11	ELECT	47uF	20% 50V	C311	1-163-235-11	CERAMIC CHIP 22PF 5% 50V
C236	1-126-964-11	ELECT	10uF	20% 50V	C312	1-163-235-11	CERAMIC CHIP 22PF 5% 50V
C237	1-163-235-11	CERAMIC CHIP	22PF	5% 50V	C313	1-163-235-11	CERAMIC CHIP 22PF 5% 50V
C238	1-163-989-11	CERAMIC CHIP	0.033uF	10% 25V	C314	1-163-239-11	CERAMIC CHIP 33PF 5% 50V
C240	1-164-004-11	CERAMIC CHIP	0.1uF	10% 25V	C315	1-163-235-11	CERAMIC CHIP 22PF 5% 50V
C241	1-163-019-00	CERAMIC CHIP	0.0068uF	10% 50V	C316	1-163-235-11	CERAMIC CHIP 22PF 5% 50V
C242	1-163-251-11	CERAMIC CHIP	100PF	5% 50V	C317	1-163-235-11	CERAMIC CHIP 22PF 5% 50V
C243	1-124-234-00	ELECT	22uF	20% 16V	C318	1-163-009-11	CERAMIC CHIP 0.001uF 10% 50V
C244	1-126-157-11	ELECT	10uF	20% 16V	C319	1-163-235-11	CERAMIC CHIP 22PF 5% 50V
C245	1-164-004-11	CERAMIC CHIP	0.1uF	10% 25V	C320	1-163-235-11	CERAMIC CHIP 22PF 5% 50V
C246	1-164-004-11	CERAMIC CHIP	0.1uF	10% 25V	C323	1-163-235-11	CERAMIC CHIP 22PF 5% 50V
C247	1-163-001-11	CERAMIC CHIP	220PF	10% 50V	C324	1-163-239-11	CERAMIC CHIP 33PF 5% 50V
C248	1-163-243-11	CERAMIC CHIP	47PF	5% 50V	C326	1-163-235-11	CERAMIC CHIP 22PF 5% 50V
C249	1-164-346-11	CERAMIC CHIP	1uF	16V	C327	1-163-235-11	CERAMIC CHIP 22PF 5% 50V
C250	1-163-037-11	CERAMIC CHIP	0.022uF	10% 25V	C328	1-163-235-11	CERAMIC CHIP 22PF 5% 50V
C251	1-163-017-00	CERAMIC CHIP	0.0047uF	5% 50V	C330	1-163-235-11	CERAMIC CHIP 22PF 5% 50V
C252	1-126-964-11	ELECT	10uF	20% 50V	C331	1-163-235-11	CERAMIC CHIP 22PF 5% 50V
C253	1-164-004-11	CERAMIC CHIP	0.1uF	10% 25V	C335	1-163-235-11	CERAMIC CHIP 22PF 5% 50V
C254	1-164-004-11	CERAMIC CHIP	0.1uF	10% 25V	C336	1-163-235-11	CERAMIC CHIP 22PF 5% 50V
C255	1-163-243-11	CERAMIC CHIP	47PF	5% 50V	C337	1-163-235-11	CERAMIC CHIP 22PF 5% 50V
C256	1-163-005-11	CERAMIC CHIP	470PF	10% 50V	C339	1-163-239-11	CERAMIC CHIP 33PF 5% 50V
C257	1-163-017-00	CERAMIC CHIP	0.0047uF	5% 50V	C340	1-163-033-00	CERAMIC CHIP 0.022uF 50V
C258	1-164-004-11	CERAMIC CHIP	0.1uF	10% 25V	C601	1-163-033-00	CERAMIC CHIP 0.022uF 50V
C259	1-126-965-11	ELECT	22uF	20% 50V	C602	1-163-033-00	CERAMIC CHIP 0.022uF 50V
C260	1-163-239-11	CERAMIC CHIP	33PF	5% 50V	C605	1-163-038-00	CERAMIC CHIP 0.1uF 25V
C261	1-163-235-11	CERAMIC CHIP	22PF	5% 50V	C606	1-163-009-11	CERAMIC CHIP 0.001uF 10% 50V
C262	1-163-239-11	CERAMIC CHIP	33PF	5% 50V	C607	1-126-916-11	ELECT 1000uF 20% 6.3V
C263	1-163-239-11	CERAMIC CHIP	33PF	5% 50V	C608	1-164-505-11	CERAMIC CHIP 2.2uF 16V
C267	1-163-235-11	CERAMIC CHIP	22PF	5% 50V	C609	1-126-963-11	ELECT 4.7uF 20% 50V
C270	1-163-235-11	CERAMIC CHIP	22PF	5% 50V	C611	1-163-033-00	CERAMIC CHIP 0.022uF 50V
C271	1-163-235-11	CERAMIC CHIP	22PF	5% 50V	C612	1-163-033-00	CERAMIC CHIP 0.022uF 50V
C272	1-163-235-11	CERAMIC CHIP	22PF	5% 50V	C615	1-163-038-00	CERAMIC CHIP 0.1uF 25V
C273	1-163-239-11	CERAMIC CHIP	33PF	5% 50V	C616	1-163-009-11	CERAMIC CHIP 0.001uF 10% 50V
C277	1-163-239-11	CERAMIC CHIP	33PF	5% 50V	C617	1-126-916-11	ELECT 1000uF 20% 6.3V
C278	1-163-239-11	CERAMIC CHIP	33PF	5% 50V	C619	1-126-963-11	ELECT 4.7uF 20% 50V
					C650	1-163-235-11	CERAMIC CHIP 22PF 5% 50V

BASE MAIN

Ref. No.	Part No.	Description	Remark	Ref. No.	Part No.	Description	Remark	
C652	1-164-222-11	CERAMIC CHIP	0.22uF	25V	D112	8-719-991-33	DIODE 1SS133T-77	
C700	1-164-346-11	CERAMIC CHIP	1uF	16V	D113	8-719-991-33	DIODE 1SS133T-77	
C701	1-163-235-11	CERAMIC CHIP	22PF	5%	50V	D114	8-719-991-33	DIODE 1SS133T-77
C702	1-164-222-11	CERAMIC CHIP	0.22uF	25V	D150	8-719-991-33	DIODE 1SS133T-77	
C703	1-163-031-11	CERAMIC CHIP	0.01uF	50V	D601	8-719-109-57	DIODE RD2.4ES-B2	
C704	1-126-925-11	ELECT	470uF	20%	10V	D602	8-719-991-33	DIODE 1SS133T-77
C705	1-164-222-11	CERAMIC CHIP	0.22uF	25V	D603	8-719-938-75	DIODE SB05-05CP	
C706	1-163-235-11	CERAMIC CHIP	22PF	5%	50V	D652	8-719-991-33	DIODE 1SS133T-77
C707	1-163-235-11	CERAMIC CHIP	22PF	5%	50V	D653	8-719-991-33	DIODE 1SS133T-77
C708	1-163-235-11	CERAMIC CHIP	22PF	5%	50V	D701	8-719-991-33	DIODE 1SS133T-77
C709	1-163-031-11	CERAMIC CHIP	0.01uF	50V	D702	8-719-991-33	DIODE 1SS133T-77	
C710	1-164-004-11	CERAMIC CHIP	0.1uF	10%	25V	D703	8-719-991-33	DIODE 1SS133T-77
C712	1-163-809-11	CERAMIC CHIP	0.047uF	10%	25V	D704	8-719-991-33	DIODE 1SS133T-77
C713	1-163-017-00	CERAMIC CHIP	0.0047uF	5%	50V	D705	8-719-991-33	DIODE 1SS133T-77
C714	1-163-235-11	CERAMIC CHIP	22PF	5%	50V		< FUSE >	
C715	1-163-235-11	CERAMIC CHIP	22PF	5%	50V	F101	1-533-542-11	FUSE (0.5A/250V)
C716	1-163-235-11	CERAMIC CHIP	22PF	5%	50V		< IC >	
C717	1-164-505-11	CERAMIC CHIP	2.2uF	16V	IC101	8-759-970-89	IC BA10358F	
C751	1-163-031-11	CERAMIC CHIP	0.01uF	50V	IC103	8-759-030-78	IC MC34118DW	
C754	1-163-031-11	CERAMIC CHIP	0.01uF	50V	IC104	8-759-463-98	IC MC34119DR2	
C755	1-126-964-11	ELECT	10uF	20%	50V	IC150	8-759-529-22	IC MT88E43
C756	1-163-031-11	CERAMIC CHIP	0.01uF	50V	IC601	8-759-482-72	IC uPC29M05HF	
C757	1-164-222-11	CERAMIC CHIP	0.22uF	25V	IC602	8-759-519-46	IC S-80730AN-DT-S	
C758	1-164-222-11	CERAMIC CHIP	0.22uF	25V	IC603	8-759-482-72	IC uPC29M05HF	
C759	1-163-031-11	CERAMIC CHIP	0.01uF	50V	IC701	8-759-530-12	IC 10497-15	
C760	1-163-031-11	CERAMIC CHIP	0.01uF	50V	IC751	8-759-534-64	IC M70012-11	
C762	1-163-251-11	CERAMIC CHIP	100PF	5%	50V	IC951	8-759-487-04	IC S-24C02AFJ-TB
C766	1-163-031-11	CERAMIC CHIP	0.01uF	50V		< JACK >		
C767	1-163-235-11	CERAMIC CHIP	22PF	5%	50V	J601	1-778-380-11	JACK, DC (POLARITY UNIFIED TYPE) (DC IN 9V)
C768	1-163-237-11	CERAMIC CHIP	27PF	5%	50V		< SHORT >	
C801	1-126-963-11	ELECT	4.7uF	20%	50V	JR13	1-216-296-00	SHORT 0
C901	1-163-235-11	CERAMIC CHIP	22PF	5%	50V	JR14	1-216-296-00	SHORT 0
C902	1-163-031-11	CERAMIC CHIP	0.01uF	50V	JR15	1-216-296-00	SHORT 0	
C903	1-163-031-11	CERAMIC CHIP	0.01uF	50V	JR16	1-216-296-00	SHORT 0	
C904	1-163-031-11	CERAMIC CHIP	0.01uF	50V	JR20	1-216-296-00	SHORT 0	
C951	1-163-031-11	CERAMIC CHIP	0.01uF	50V	JR21	1-216-296-00	SHORT 0	
		< CONNECTOR >			JR24	1-216-296-00	SHORT 0	
* CN202	1-506-998-11	PIN, CONNECTOR (PC BOARD) 2P			JR25	1-216-296-00	SHORT 0	
* CN601	1-506-999-11	PIN, CONNECTOR (PC BOARD) 3P			JR26	1-216-296-00	SHORT 0	
* CN801	1-566-007-11	PIN, CONNECTOR (PC BOARD) 10P			JR27	1-216-296-00	SHORT 0	
CN802	1-566-010-11	PIN, CONNECTOR (PC BOARD) 13P			JR28	1-216-296-00	SHORT 0	
* CN901	1-779-773-11	PIN, CONNECTOR (PC BOARD) 8P			JR29	1-216-295-00	SHORT 0	
* CN902	1-779-774-11	PIN, CONNECTOR (PC BOARD) 16P			JR30	1-216-295-00	SHORT 0	
		< DIODE >			JR100	1-216-295-00	SHORT 0	
D100	8-719-991-33	DIODE 1SS133T-77			JR201	1-216-295-00	SHORT 0	
D102	8-719-109-89	DIODE RD5.6ESB2			JR202	1-216-296-00	SHORT 0	
D103	8-719-109-89	DIODE RD5.6ESB2			JR203	1-216-295-00	SHORT 0	
D104	8-719-991-33	DIODE 1SS133T-77			JR204	1-216-296-00	SHORT 0	
D105	8-719-970-02	DIODE 1SR139-400			JR205	1-216-295-00	SHORT 0	
D106	8-719-970-02	DIODE 1SR139-400				< COIL >		
D107	8-719-970-02	DIODE 1SR139-400			L101	1-410-470-11	INDUCTOR 10uH	
D108	8-719-970-02	DIODE 1SR139-400			L102	1-410-470-11	INDUCTOR 10uH	
D110	8-719-160-55	DIODE RD12F-B1						
D111	8-719-991-33	DIODE 1SS133T-77						

BASE MAIN

Ref. No.	Part No.	Description	Remark	Ref. No.	Part No.	Description	Remark
L201	1-414-481-11	INDUCTOR 68nH		R109	1-216-113-00	METAL CHIP 470K	5% 1/10W
L202	1-414-481-11	INDUCTOR 68nH		R110	1-249-417-11	CARBON 1K	5% 1/4W
L601	1-410-468-11	INDUCTOR 6.8uH		R111	1-216-037-00	METAL CHIP 330	5% 1/10W
L602	1-410-468-11	INDUCTOR 6.8uH		R142	1-216-077-00	METAL CHIP 15K	5% 1/10W
L611	1-410-468-11	INDUCTOR 6.8uH		R150	1-216-121-00	RES,CHIP 1M	5% 1/10W
L612	1-410-468-11	INDUCTOR 6.8uH		R151	1-216-121-00	RES,CHIP 1M	5% 1/10W
L750	1-412-945-11	INDUCTOR 3.3uH		R152	1-216-065-00	RES,CHIP 4.7K	5% 1/10W
< MODULAR JACK >				R153	1-216-081-00	METAL CHIP 22K	5% 1/10W
MJ101	1-766-250-11	JACK, MODULAR (2C) 6P (LINE)		R154	1-216-085-00	METAL CHIP 33K	5% 1/10W
< PHOTO COUPLER >				R155	1-216-065-00	RES,CHIP 4.7K	5% 1/10W
PH101	8-719-156-73	PHOTO COUPLER PS2501-1LA		R156	1-216-097-00	RES,CHIP 100K	5% 1/10W
PH102	8-719-156-73	PHOTO COUPLER PS2501-1LA		R157	1-216-073-00	METAL CHIP 10K	5% 1/10W
PH103	8-749-011-58	PHOTO COUPLER PS2533-1		R158	1-216-097-00	RES,CHIP 100K	5% 1/10W
< TRANSISTOR >				R159	1-216-097-00	RES,CHIP 100K	5% 1/10W
Q101	8-729-032-66	TRANSISTOR 2SC5069-TD		R160	1-216-097-00	RES,CHIP 100K	5% 1/10W
Q102	8-729-026-49	TRANSISTOR 2SA1037AK-T146-R		R161	1-216-121-00	RES,CHIP 1M	5% 1/10W
Q103	8-729-120-28	TRANSISTOR 2SC1623-L5L6		R162	1-216-121-00	RES,CHIP 1M	5% 1/10W
Q151	8-729-120-28	TRANSISTOR 2SC1623-L5L6		R163	1-216-073-00	METAL CHIP 10K	5% 1/10W
Q201	8-729-026-49	TRANSISTOR 2SA1037AK-T146-R		R164	1-216-073-00	METAL CHIP 10K	5% 1/10W
Q202	8-729-120-28	TRANSISTOR 2SC1623-L5L6		R165	1-216-089-00	RES,CHIP 47K	5% 1/10W
Q203	8-729-120-28	TRANSISTOR 2SC1623-L5L6		R166	1-216-089-00	RES,CHIP 47K	5% 1/10W
Q204	8-729-120-28	TRANSISTOR 2SC1623-L5L6		R201	1-216-097-00	RES,CHIP 100K	5% 1/10W
Q206	8-729-120-28	TRANSISTOR 2SC1623-L5L6		R202	1-216-093-00	METAL CHIP 68K	5% 1/10W
Q207	8-729-120-28	TRANSISTOR 2SC1623-L5L6		R203	1-216-049-11	RES,CHIP 1K	5% 1/10W
Q208	8-729-120-28	TRANSISTOR 2SC1623-L5L6		R204	1-216-085-00	METAL CHIP 33K	5% 1/10W
Q209	8-729-120-28	TRANSISTOR 2SC1623-L5L6		R205	1-216-073-00	METAL CHIP 10K	5% 1/10W
Q210	8-729-120-28	TRANSISTOR 2SC1623-L5L6		R206	1-216-109-00	METAL CHIP 330K	5% 1/10W
Q211	8-729-120-28	TRANSISTOR 2SC1623-L5L6		R207	1-216-061-00	METAL CHIP 3.3K	5% 1/10W
Q212	8-729-120-28	TRANSISTOR 2SC1623-L5L6		R208	1-216-025-00	RES,CHIP 100	5% 1/10W
Q213	8-729-120-28	TRANSISTOR 2SC1623-L5L6		R209	1-216-073-00	METAL CHIP 10K	5% 1/10W
Q214	8-729-120-28	TRANSISTOR 2SC1623-L5L6		R210	1-216-025-00	RES,CHIP 100	5% 1/10W
Q215	8-729-120-28	TRANSISTOR 2SC1623-L5L6		R211	1-216-089-00	RES,CHIP 47K	5% 1/10W
Q216	8-729-120-28	TRANSISTOR 2SC1623-L5L6		R212	1-216-073-00	METAL CHIP 10K	5% 1/10W
Q217	8-729-120-28	TRANSISTOR 2SC1623-L5L6		R213	1-216-109-00	METAL CHIP 330K	5% 1/10W
Q601	8-729-120-28	TRANSISTOR 2SC1623-L5L6		R214	1-216-109-00	METAL CHIP 330K	5% 1/10W
Q651	8-729-922-34	TRANSISTOR 2SD1758F5-QR		R215	1-216-069-00	METAL CHIP 6.8K	5% 1/10W
Q652	8-729-026-49	TRANSISTOR 2SA1037AK-T146-R		R216	1-216-041-00	METAL CHIP 470	5% 1/10W
Q653	8-729-120-28	TRANSISTOR 2SC1623-L5L6		R217	1-216-049-11	RES,CHIP 1K	5% 1/10W
Q654	8-729-026-49	TRANSISTOR 2SA1037AK-T146-R		R218	1-216-089-00	RES,CHIP 47K	5% 1/10W
Q655	8-729-120-28	TRANSISTOR 2SC1623-L5L6		R219	1-216-097-00	RES,CHIP 100K	5% 1/10W
Q750	8-729-120-28	TRANSISTOR 2SC1623-L5L6		R220	1-216-105-00	RES,CHIP 220K	5% 1/10W
Q751	8-729-120-28	TRANSISTOR 2SC1623-L5L6		R221	1-216-073-00	METAL CHIP 10K	5% 1/10W
Q852	8-729-120-28	TRANSISTOR 2SC1623-L5L6		R222	1-216-073-00	METAL CHIP 10K	5% 1/10W
< RESISTOR/COIL >				R223	1-216-073-00	METAL CHIP 10K	5% 1/10W
R11	1-216-041-00	METAL CHIP 470	5% 1/10W	R224	1-216-025-00	RES,CHIP 100	5% 1/10W
R12	1-216-041-00	METAL CHIP 470	5% 1/10W	R225	1-216-077-00	METAL CHIP 15K	5% 1/10W
R101	1-215-877-11	METAL OXIDE 22K	5% 1W	R226	1-216-105-00	RES,CHIP 220K	5% 1/10W
R102	1-215-861-00	METAL OXIDE 47	5% 1W	R227	1-216-109-00	METAL CHIP 330K	5% 1/10W
R103	1-215-859-00	METAL OXIDE 22	5% 1W	R228	1-216-065-00	RES,CHIP 4.7K	5% 1/10W
R104	1-216-073-00	METAL CHIP 10K	5% 1/10W	R229	1-216-049-11	RES,CHIP 1K	5% 1/10W
R105	1-216-105-00	RES,CHIP 220K	5% 1/10W	R230	1-216-105-00	RES,CHIP 220K	5% 1/10W
R106	1-216-065-00	RES,CHIP 4.7K	5% 1/10W	R231	1-216-093-00	METAL CHIP 68K	5% 1/10W
R107	1-216-073-00	METAL CHIP 10K	5% 1/10W	R232	1-216-077-00	METAL CHIP 15K	5% 1/10W
R108	1-216-105-00	RES,CHIP 220K	5% 1/10W	R233	1-216-025-00	RES,CHIP 100	5% 1/10W
				R234	1-216-073-00	METAL CHIP 10K	5% 1/10W
				R235	1-216-053-00	METAL CHIP 1.5K	5% 1/10W
				R236	1-216-097-00	RES,CHIP 100K	5% 1/10W

BASE MAIN

Ref. No.	Part No.	Description	Quantity	Unit	Remark	Ref. No.	Part No.	Description	Quantity	Unit	Remark
R237	1-216-097-00	RES,CHIP	100K	5%	1/10W						
R238	1-216-073-00	METAL CHIP	10K	5%	1/10W	R643	1-216-057-00	METAL CHIP	2.2K	5%	1/10W
R239	1-216-085-00	METAL CHIP	33K	5%	1/10W	R650	1-249-403-11	CARBON	68	5%	1/4W
						R651	1-249-403-11	CARBON	68	5%	1/4W
R240	1-216-073-00	METAL CHIP	10K	5%	1/10W	R652	1-216-057-00	METAL CHIP	2.2K	5%	1/10W
R241	1-216-097-00	RES,CHIP	100K	5%	1/10W	R653	1-249-393-11	CARBON	10	5%	1/4W
R242	1-216-085-00	METAL CHIP	33K	5%	1/10W						
R243	1-216-109-00	METAL CHIP	330K	5%	1/10W	R654	1-216-105-00	RES,CHIP	220K	5%	1/10W
R244	1-216-097-00	RES,CHIP	100K	5%	1/10W	R655	1-216-101-00	METAL CHIP	150K	5%	1/10W
						R656	1-216-097-00	RES,CHIP	100K	5%	1/10W
R245	1-216-057-00	METAL CHIP	2.2K	5%	1/10W	R657	1-216-089-00	RES,CHIP	47K	5%	1/10W
R246	1-216-113-00	METAL CHIP	470K	5%	1/10W	R658	1-216-041-00	METAL CHIP	470	5%	1/10W
R247	1-216-025-00	RES,CHIP	100	5%	1/10W						
R248	1-216-113-00	METAL CHIP	470K	5%	1/10W	R659	1-216-101-00	METAL CHIP	150K	5%	1/10W
R249	1-216-049-11	RES,CHIP	1K	5%	1/10W	R660	1-216-037-00	METAL CHIP	330	5%	1/10W
						R661	1-249-389-11	CARBON	4.7	5%	1/4W
R252	1-216-089-00	RES,CHIP	47K	5%	1/10W	R662	1-216-081-00	METAL CHIP	22K	5%	1/10W
R253	1-216-089-00	RES,CHIP	47K	5%	1/10W	R664	1-216-057-00	METAL CHIP	2.2K	5%	1/10W
R254	1-216-057-00	METAL CHIP	2.2K	5%	1/10W						
R255	1-216-089-00	RES,CHIP	47K	5%	1/10W	R670	1-249-387-11	CARBON	3.3	5%	1/4W
R256	1-216-097-00	RES,CHIP	100K	5%	1/10W	R671	1-249-387-11	CARBON	3.3	5%	1/4W
						R700	1-216-065-00	RES,CHIP	4.7K	5%	1/10W
R257	1-414-481-11	INDUCTOR	68nH			R701	1-216-025-00	RES,CHIP	100	5%	1/10W
R258	1-216-101-00	METAL CHIP	150K	5%	1/10W	R702	1-218-754-11	METAL CHIP	120K	0.5%	1/10W
R259	1-216-049-11	RES,CHIP	1K	5%	1/10W						
R260	1-216-097-00	RES,CHIP	100K	5%	1/10W	R703	1-216-009-00	METAL CHIP	22	5%	1/10W
R261	1-216-109-00	METAL CHIP	330K	5%	1/10W	R704	1-216-081-00	METAL CHIP	22K	5%	1/10W
						R705	1-216-025-00	RES,CHIP	100	5%	1/10W
R262	1-216-025-00	RES,CHIP	100	5%	1/10W	R706	1-216-041-00	METAL CHIP	470	5%	1/10W
R263	1-216-065-00	RES,CHIP	4.7K	5%	1/10W	R707	1-216-033-00	METAL CHIP	220	5%	1/10W
R264	1-216-089-00	RES,CHIP	47K	5%	1/10W						
R265	1-216-113-00	METAL CHIP	470K	5%	1/10W	R708	1-216-065-00	RES,CHIP	4.7K	5%	1/10W
R266	1-216-089-00	RES,CHIP	47K	5%	1/10W	R709	1-216-081-00	METAL CHIP	22K	5%	1/10W
						R710	1-216-041-00	METAL CHIP	470	5%	1/10W
R267	1-216-089-00	RES,CHIP	47K	5%	1/10W	R711	1-216-041-00	METAL CHIP	470	5%	1/10W
R268	1-216-105-00	RES,CHIP	220K	5%	1/10W	R712	1-216-041-00	METAL CHIP	470	5%	1/10W
R269	1-216-097-00	RES,CHIP	100K	5%	1/10W						
R270	1-216-105-00	RES,CHIP	220K	5%	1/10W	R713	1-216-041-00	METAL CHIP	470	5%	1/10W
R271	1-216-025-00	RES,CHIP	100	5%	1/10W	R714	1-216-041-00	METAL CHIP	470	5%	1/10W
						R715	1-216-041-00	METAL CHIP	470	5%	1/10W
R272	1-216-013-00	METAL CHIP	33	5%	1/10W	R716	1-216-041-00	METAL CHIP	470	5%	1/10W
R273	1-216-077-00	METAL CHIP	15K	5%	1/10W	R717	1-216-041-00	METAL CHIP	470	5%	1/10W
R274	1-216-041-00	METAL CHIP	470	5%	1/10W						
R275	1-216-065-00	RES,CHIP	4.7K	5%	1/10W	R718	1-216-041-00	METAL CHIP	470	5%	1/10W
R276	1-216-081-00	METAL CHIP	22K	5%	1/10W	R719	1-216-041-00	METAL CHIP	470	5%	1/10W
						R720	1-216-041-00	METAL CHIP	470	5%	1/10W
R277	1-216-081-00	METAL CHIP	22K	5%	1/10W	R721	1-216-041-00	METAL CHIP	470	5%	1/10W
R278	1-216-097-00	RES,CHIP	100K	5%	1/10W	R722	1-216-041-00	METAL CHIP	470	5%	1/10W
R279	1-216-101-00	METAL CHIP	150K	5%	1/10W						
R280	1-216-089-00	RES,CHIP	47K	5%	1/10W	R723	1-216-041-00	METAL CHIP	470	5%	1/10W
R281	1-216-049-11	RES,CHIP	1K	5%	1/10W	R724	1-216-041-00	METAL CHIP	470	5%	1/10W
						R725	1-216-041-00	METAL CHIP	470	5%	1/10W
R282	1-216-065-00	RES,CHIP	4.7K	5%	1/10W	R726	1-216-041-00	METAL CHIP	470	5%	1/10W
R283	1-216-049-11	RES,CHIP	1K	5%	1/10W	R727	1-216-041-00	METAL CHIP	470	5%	1/10W
R284	1-216-041-00	METAL CHIP	470	5%	1/10W						
R285	1-216-069-00	METAL CHIP	6.8K	5%	1/10W	R728	1-216-041-00	METAL CHIP	470	5%	1/10W
R286	1-216-049-11	RES,CHIP	1K	5%	1/10W	R729	1-216-041-00	METAL CHIP	470	5%	1/10W
						R730	1-216-041-00	METAL CHIP	470	5%	1/10W
R287	1-216-049-11	RES,CHIP	1K	5%	1/10W	R731	1-216-041-00	METAL CHIP	470	5%	1/10W
R291	1-216-097-00	RES,CHIP	100K	5%	1/10W	R732	1-216-041-00	METAL CHIP	470	5%	1/10W
R292	1-216-025-00	RES,CHIP	100	5%	1/10W						
R293	1-216-041-00	METAL CHIP	470	5%	1/10W	R733	1-216-041-00	METAL CHIP	470	5%	1/10W
R294	1-216-081-00	METAL CHIP	22K	5%	1/10W	R734	1-216-081-00	METAL CHIP	22K	5%	1/10W
						R735	1-216-049-11	RES,CHIP	1K	5%	1/10W
R295	1-216-081-00	METAL CHIP	22K	5%	1/10W	R736	1-216-041-00	METAL CHIP	470	5%	1/10W
R296	1-216-073-00	METAL CHIP	10K	5%	1/10W	R750	1-216-033-00	METAL CHIP	220	5%	1/10W
R300	1-216-311-00	METAL CHIP	6.8	5%	1/10W						
R601	1-216-069-00	METAL CHIP	6.8K	5%	1/10W	R751	1-216-073-00	METAL CHIP	10K	5%	1/10W
R602	1-216-073-00	METAL CHIP	10K	5%	1/10W	R754	1-216-045-00	METAL CHIP	680	5%	1/10W

BASE MAIN	BASE MICROPHONE	HAND MAIN
------------------	------------------------	------------------

Ref. No.	Part No.	Description			Remark
R755	1-216-073-00	METAL CHIP	10K	5%	1/10W
R759	1-216-057-00	METAL CHIP	2.2K	5%	1/10W
R760	1-216-073-00	METAL CHIP	10K	5%	1/10W
R761	1-216-041-00	METAL CHIP	470	5%	1/10W
R762	1-216-073-00	METAL CHIP	10K	5%	1/10W
R764	1-216-041-00	METAL CHIP	470	5%	1/10W
R765	1-216-001-00	METAL CHIP	10	5%	1/10W
R766	1-218-754-11	METAL CHIP	120K	0.5%	1/10W
R767	1-216-097-00	RES,CHIP	100K	5%	1/10W
R768	1-216-049-11	RES,CHIP	1K	5%	1/10W
R769	1-216-065-00	RES,CHIP	4.7K	5%	1/10W
R771	1-216-121-00	RES,CHIP	1M	5%	1/10W
R772	1-216-025-00	RES,CHIP	100	5%	1/10W
R781	1-216-041-00	METAL CHIP	470	5%	1/10W
R782	1-216-017-00	RES,CHIP	47	5%	1/10W
R787	1-216-041-00	METAL CHIP	470	5%	1/10W
R790	1-216-041-00	METAL CHIP	470	5%	1/10W
R792	1-216-041-00	METAL CHIP	470	5%	1/10W
R793	1-216-041-00	METAL CHIP	470	5%	1/10W
R794	1-216-041-00	METAL CHIP	470	5%	1/10W
R798	1-216-049-11	RES,CHIP	1K	5%	1/10W
R800	1-216-017-00	RES,CHIP	47	5%	1/10W
R801	1-216-041-00	METAL CHIP	470	5%	1/10W
R802	1-216-041-00	METAL CHIP	470	5%	1/10W
R803	1-216-041-00	METAL CHIP	470	5%	1/10W
R901	1-216-041-00	METAL CHIP	470	5%	1/10W
R902	1-216-041-00	METAL CHIP	470	5%	1/10W
R904	1-216-097-00	RES,CHIP	100K	5%	1/10W
R906	1-216-033-00	METAL CHIP	220	5%	1/10W
R911	1-216-001-00	METAL CHIP	10	5%	1/10W
R913	1-216-041-00	METAL CHIP	470	5%	1/10W
R914	1-216-041-00	METAL CHIP	470	5%	1/10W
R954	1-216-073-00	METAL CHIP	10K	5%	1/10W
R955	1-216-089-00	RES,CHIP	47K	5%	1/10W
R956	1-216-089-00	RES,CHIP	47K	5%	1/10W
R957	1-216-073-00	METAL CHIP	10K	5%	1/10W
< RF UNIT >					
RFU901	1-475-890-11	RF UNIT			
< VARIABLE RESISTOR >					
RV201	1-223-862-11	RES, VAR, SLIDE 20K (SPEAKER VOLUME)			
< SPARK GAP >					
SG101	1-533-751-11	ABSORBER, SURGE			
< SWITCH >					
SW601	1-571-532-32	SWITCH, TACTIL (RESET)			
SW951	1-692-990-21	SWITCH, SLIDE (DIAL MODE)			
SW952	1-692-991-22	SWITCH, SLIDE (RINGER)			
< TRANSFORMER >					
T101	1-431-832-11	TRANSFORMER, LINE			
< VIBRATOR >					
X150	1-567-505-11	OSCILLATOR, CRYSTAL (3.579545MHZ)			

Ref. No.	Part No.	Description			Remark
X752	1-767-566-21	VIBRATOR, CRYSTAL (9.6MHZ)			

*	1-671-565-11	BASE MICROPHONE BOARD			

< CAPACITOR >					
C0	1-163-239-11	CERAMIC CHIP	33PF	5%	50V
C501	1-163-235-11	CERAMIC CHIP	22PF	5%	50V
C502	1-163-235-11	CERAMIC CHIP	22PF	5%	50V
< COIL >					
L501	1-414-481-11	INDUCTOR	68nH		
L502	1-414-481-11	INDUCTOR	68nH		
< MICROPHONE >					
MIC501	1-542-118-11	MICROPHONE, ELECTRET CONDENSER (MIC)			

*	A-3622-209-A	HAND MAIN BOARD, COMPLETE			

< BUZZER >					
BZ401	1-544-603-11	BUZZER			
< CAPACITOR >					
C0	1-163-239-11	CERAMIC CHIP	33PF	5%	50V
C1	1-163-239-11	CERAMIC CHIP	33PF	5%	50V
C3	1-163-239-11	CERAMIC CHIP	33PF	5%	50V
C4	1-163-235-11	CERAMIC CHIP	22PF	5%	50V
C5	1-163-239-11	CERAMIC CHIP	33PF	5%	50V
C6	1-163-239-11	CERAMIC CHIP	33PF	5%	50V
C8	1-164-182-11	CERAMIC CHIP	0.0033uF	10%	50V
C9	1-125-822-11	TANTALUM	10uF	20%	10V
C14	1-163-021-11	CERAMIC CHIP	0.01uF	10%	50V
C16	1-125-822-11	TANTALUM	10uF	20%	10V
C17	1-125-822-11	TANTALUM	10uF	20%	10V
C19	1-125-822-11	TANTALUM	10uF	20%	10V
C301	1-126-206-11	ELECT CHIP	100uF	20%	6.3V
C302	1-163-031-11	CERAMIC CHIP	0.01uF		50V
C303	1-163-031-11	CERAMIC CHIP	0.01uF		50V
C307	1-163-031-11	CERAMIC CHIP	0.01uF		50V
C308	1-164-005-11	CERAMIC CHIP	0.47uF		25V
C401	1-163-031-11	CERAMIC CHIP	0.01uF		50V
C402	1-126-206-11	ELECT CHIP	100uF	20%	6.3V
C403	1-163-031-11	CERAMIC CHIP	0.01uF		50V
C404	1-164-222-11	CERAMIC CHIP	0.22uF		25V
C407	1-163-235-11	CERAMIC CHIP	22PF	5%	50V
C410	1-163-235-11	CERAMIC CHIP	22PF	5%	50V
C412	1-107-682-11	CERAMIC CHIP	1uF	10%	16V

HAND MAIN

Ref. No.	Part No.	Description	Remark	Ref. No.	Part No.	Description	Remark
C413	1-125-822-11	TANTALUM 10uF 20%	10V	JR6	1-216-295-00	SHORT 0	
C415	1-163-243-11	CERAMIC CHIP 47PF 5%	50V	JR7	1-216-295-00	SHORT 0	
C416	1-163-243-11	CERAMIC CHIP 47PF 5%	50V	JR10	1-216-295-00	SHORT 0	
C420	1-163-239-11	CERAMIC CHIP 33PF 5%	50V	JR15	1-216-296-00	SHORT 0	
C501	1-163-235-11	CERAMIC CHIP 22PF 5%	50V	JR18	1-216-296-00	SHORT 0	
C502	1-163-237-11	CERAMIC CHIP 27PF 5%	50V	JR20	1-216-296-00	SHORT 0	
C505	1-163-031-11	CERAMIC CHIP 0.01uF	50V	JR21	1-216-295-00	SHORT 0	
C506	1-163-031-11	CERAMIC CHIP 0.01uF	50V	JR24	1-216-295-00	SHORT 0	
C507	1-162-974-11	CERAMIC CHIP 0.01uF	50V			< COIL >	
C508	1-163-031-11	CERAMIC CHIP 0.01uF	50V				
C509	1-124-779-00	ELECT CHIP 10uF 20%	16V	L501	1-410-198-51	INDUCTOR CHIP 3.3uH	
C510	1-163-031-11	CERAMIC CHIP 0.01uF	50V			< LIQUID CRYSTAL DISPLAY >	
C511	1-164-222-11	CERAMIC CHIP 0.22uF	25V				
C512	1-164-222-11	CERAMIC CHIP 0.22uF	25V	LCD501	1-475-241-11	LCD UNIT	
C513	1-163-031-11	CERAMIC CHIP 0.01uF	50V			< MICROPHONE >	
C514	1-162-919-11	CERAMIC CHIP 22PF 5%	50V				
C515	1-126-603-11	ELECT CHIP 4.7uF 20%	35V	MIC401	1-542-118-11	MICROPHONE, ELECTRET CONDENSER	
C516	1-163-251-11	CERAMIC CHIP 100PF 5%	50V			< TRANSISTOR >	
C523	1-163-031-11	CERAMIC CHIP 0.01uF	50V				
C530	1-126-603-11	ELECT CHIP 4.7uF 20%	35V	Q1	8-729-120-28	TRANSISTOR 2SC1623-L5L6	
C555	1-164-346-11	CERAMIC CHIP 1uF	16V	Q301	8-729-120-28	TRANSISTOR 2SC1623-L5L6	
C585	1-163-031-11	CERAMIC CHIP 0.01uF	50V	Q302	8-729-026-49	TRANSISTOR 2SA1037AK-T146-R	
		< CONNECTOR >		Q303	8-729-120-28	TRANSISTOR 2SC1623-L5L6	
CN301	1-766-180-11	PIN, CONNECTOR (PC BOARD) 2P		Q501	8-729-026-49	TRANSISTOR 2SA1037AK-T146-R	
* CN302	1-506-985-11	PIN, CONNECTOR (PC BOARD) 3P		Q502	8-729-120-28	TRANSISTOR 2SC1623-L5L6	
* CN401	1-506-984-11	PIN, CONNECTOR (PC BOARD) 2P		Q503	8-729-026-49	TRANSISTOR 2SA1037AK-T146-R	
* CN501	1-779-773-11	PIN, CONNECTOR (PC BOARD) 8P		Q504	8-729-120-28	TRANSISTOR 2SC1623-L5L6	
* CN502	1-779-774-11	PIN, CONNECTOR (PC BOARD) 16P		Q505	8-729-120-28	TRANSISTOR 2SC1623-L5L6	
CN503	1-568-237-11	CONNECTOR, FPC (1.0MM) (ZIF) 14P				< RESISTOR/CAPACITOR/COIL >	
		< DIODE >		R1	1-216-295-00	SHORT 0	
D301	8-719-938-75	DIODE SB05-05CP		R2	1-164-344-11	CERAMIC CHIP 0.068uF 10%	25V
D302	8-719-938-75	DIODE SB05-05CP		R3	1-216-097-00	RES,CHIP 100K 5%	1/10W
D303	8-719-938-75	DIODE SB05-05CP		R4	1-414-481-11	INDUCTOR 68nH	
D304	8-719-938-75	DIODE SB05-05CP		R5	1-216-065-00	RES,CHIP 4.7K 5%	1/10W
D305	8-719-914-43	DIODE DAN202K		R7	1-414-481-11	INDUCTOR 68nH	
D306	8-719-066-61	DIODE RD5.6P-T1		R8	1-216-081-00	METAL CHIP 22K 5%	1/10W
D401	8-719-914-43	DIODE DAN202K		R9	1-216-081-00	METAL CHIP 22K 5%	1/10W
D402	8-719-914-43	DIODE DAN202K		R11	1-216-295-00	SHORT 0	
D502	8-719-914-42	DIODE DA204K		R12	1-216-295-00	SHORT 0	
D503	8-719-914-42	DIODE DA204K		R13	1-216-295-00	SHORT 0	
D505	8-719-914-42	DIODE DA204K		R14	1-216-295-00	SHORT 0	
		< IC >		R17	1-216-033-00	METAL CHIP 220 5%	1/10W
IC301	8-759-519-46	IC S-80730AN-DT-S		R18	1-216-295-00	SHORT 0	
IC401	8-759-530-12	IC 10497-15		R19	1-216-041-00	METAL CHIP 470 5%	1/10W
IC501	8-759-534-64	IC M70012-11		R20	1-216-295-00	SHORT 0	
IC502	8-759-487-05	IC S-24C16AFJ-TB		R21	1-216-295-00	SHORT 0	
		< SHORT >		R22	1-216-053-00	METAL CHIP 1.5K 5%	1/10W
JR1	1-216-296-00	SHORT 0		R30	1-216-101-00	METAL CHIP 150K 5%	1/10W
JR2	1-216-296-00	SHORT 0		R301	1-216-093-00	METAL CHIP 68K 5%	1/10W
JR3	1-216-296-00	SHORT 0		R302	1-216-085-00	METAL CHIP 33K 5%	1/10W
JR4	1-216-296-00	SHORT 0		R303	1-216-097-00	RES,CHIP 100K 5%	1/10W
JR5	1-216-295-00	SHORT 0		R304	1-216-069-00	METAL CHIP 6.8K 5%	1/10W
				R305	1-216-073-00	METAL CHIP 10K 5%	1/10W
				R308	1-216-089-91	RES,CHIP 47K 5%	1/10W
				R309	1-216-073-00	METAL CHIP 10K 5%	1/10W
				R310	1-216-049-11	RES,CHIP 1K 5%	1/10W

HAND MAIN

Ref. No.	Part No.	Description	Remark
R311	1-216-097-00	RES,CHIP	100K 5% 1/10W
R312	1-216-089-00	RES,CHIP	47K 5% 1/10W
R401	1-216-017-00	RES,CHIP	47 5% 1/10W
R402	1-218-754-11	METAL CHIP	120K 0.5% 1/10W
R410	1-216-097-00	RES,CHIP	100K 5% 1/10W
R413	1-216-033-00	METAL CHIP	220 5% 1/10W
R414	1-216-033-00	METAL CHIP	220 5% 1/10W
R415	1-216-061-00	METAL CHIP	3.3K 5% 1/10W
R501	1-216-121-00	RES,CHIP	1M 5% 1/10W
R502	1-216-025-00	RES,CHIP	100 5% 1/10W
R506	1-216-001-00	METAL CHIP	10 5% 1/10W
R507	1-218-754-11	METAL CHIP	120K 0.5% 1/10W
R508	1-218-754-11	METAL CHIP	120K 0.5% 1/10W
R509	1-218-756-11	METAL CHIP	150K 0.5% 1/10W
R510	1-216-073-00	METAL CHIP	10K 5% 1/10W
R511	1-216-121-00	RES,CHIP	1M 5% 1/10W
R513	1-216-821-11	METAL CHIP	1K 5% 1/16W
R514	1-216-097-00	RES,CHIP	100K 5% 1/10W
R515	1-216-065-00	RES,CHIP	4.7K 5% 1/10W
R517	1-216-057-00	METAL CHIP	2.2K 5% 1/10W
R527	1-216-073-00	METAL CHIP	10K 5% 1/10W
R528	1-216-097-00	RES,CHIP	100K 5% 1/10W
R529	1-216-073-00	METAL CHIP	10K 5% 1/10W
R530	1-216-049-11	RES,CHIP	1K 5% 1/10W
R531	1-216-049-11	RES,CHIP	1K 5% 1/10W
R532	1-216-049-11	RES,CHIP	1K 5% 1/10W
R533	1-216-049-11	RES,CHIP	1K 5% 1/10W
R534	1-216-295-00	SHORT	0
R536	1-216-049-11	RES,CHIP	1K 5% 1/10W
R537	1-216-049-11	RES,CHIP	1K 5% 1/10W
R538	1-216-049-11	RES,CHIP	1K 5% 1/10W
R539	1-216-295-00	SHORT	0
R542	1-216-296-00	SHORT	0
R544	1-216-817-11	METAL CHIP	470 5% 1/16W
R545	1-216-805-11	METAL CHIP	47 5% 1/16W
R546	1-216-821-11	METAL CHIP	1K 5% 1/16W
R547	1-216-864-11	METAL CHIP	0 5% 1/16W
R548	1-216-295-00	SHORT	0
R549	1-216-295-00	SHORT	0
R550	1-216-295-00	SHORT	0
R551	1-216-041-00	METAL CHIP	470 5% 1/10W
R552	1-216-041-00	METAL CHIP	470 5% 1/10W
R554	1-216-817-11	METAL CHIP	470 5% 1/16W
R555	1-216-817-11	METAL CHIP	470 5% 1/16W
R556	1-216-817-11	METAL CHIP	470 5% 1/16W
R557	1-216-017-00	RES,CHIP	47 5% 1/10W
R558	1-216-041-00	METAL CHIP	470 5% 1/10W
R560	1-216-041-00	METAL CHIP	470 5% 1/10W
R570	1-216-073-00	METAL CHIP	10K 5% 1/10W
R571	1-216-073-00	METAL CHIP	10K 5% 1/10W
R572	1-216-073-00	METAL CHIP	10K 5% 1/10W
R573	1-216-073-00	METAL CHIP	10K 5% 1/10W
R574	1-216-097-00	RES,CHIP	100K 5% 1/10W
R575	1-216-097-00	RES,CHIP	100K 5% 1/10W
R582	1-216-073-00	METAL CHIP	10K 5% 1/10W
R583	1-216-045-00	METAL CHIP	680 5% 1/10W
R584	1-216-833-11	METAL CHIP	10K 5% 1/16W
R585	1-216-813-11	METAL CHIP	220 5% 1/16W

Ref. No.	Part No.	Description	Remark
R586	1-216-073-00	METAL CHIP	10K 5% 1/10W
R587	1-216-298-00	METAL CHIP	2.2 5% 1/10W
R590	1-216-041-00	METAL CHIP	470 5% 1/10W
R591	1-216-041-00	METAL CHIP	470 5% 1/10W
R593	1-216-827-11	METAL CHIP	3.3K 5% 1/16W
R594	1-216-827-11	METAL CHIP	3.3K 5% 1/16W
< RF UNIT >			
RFU501	1-475-890-11	RF UNIT	
< SWITCH >			
S501	1-692-991-11	SWITCH, SLIDE (BATT SAVE/RING ON)	
S502	1-570-909-21	SWITCH, TACTIL (REFLOW TYPE) (TALK/CALL WAITING/FLASH)	
SW601	1-475-338-11	ENCODER, ROTARY (JOG)	
< VIBRATOR >			
X501	1-767-566-21	VIBRATOR, CRYSTAL (9.6MHz)	

MISCELLANEOUS			

8	1-771-066-21	SWITCH, RUBBER KEY (HAND)	
52	1-771-364-11	SWITCH, RUBBER KEY (BASE)	
ANT501	1-501-933-21	ANTENNA	
ANT901	1-501-998-11	ANTENNA, ROD	
LCD801	1-475-724-11	LCD UNIT	
SP101	1-505-802-11	SPEAKER (5.7cm)	
SP401	1-504-829-11	SPEAKER (28mm)	

HARDWARE LIST			

#1	7-685-650-79	SCREW +P 3X16 TYPE2 NON-SLIT	
#2	7-685-135-19	SCREW +BTP 2.6X10 TYPE2 N-S	
#3	7-685-134-19	SCREW +BTP 2.6X8 TYPE2 N-S	
#4	7-685-648-79	SCREW +P 3X12 TYPE2 NON-SLIT	

ACCESSORIES & PACKING MATERIALS			

△	1-473-475-61	ADAPTOR, AC (AC-T46)	
	1-528-884-11	BATTERY, NICKEL CADMIUM(BP-T24)	
	1-696-453-21	CORD (WITH MODULAR PLUG)(LINE) (22cm)	
	1-696-454-11	CORD (WITH MODULAR PLUG)(LINE) (2m15cm)	
	3-012-379-21	CASE (WALL HOOK)	
	3-026-394-11	GUIDE, QUICK START (US)	
	3-026-394-21	GUIDE, QUICK START (Canadian)	
	3-026-932-01	LABEL (ADDRESS. B)	
	3-862-954-11	MANUAL, INSTRUCTION (ENGLISH, SPANISH) (US)	
	3-862-954-21	MANUAL, INSTRUCTION (ENGLISH, FRENCH) (Canadian)	

The components identified by mark △ or dotted line with mark △ are critical for safety. Replace only with part number specified.	Les composants identifiés par une marque △ sont critiques pour la sécurité. Ne les remplacer que par une pièce portant le numéro spécifié.
--	--